



(11) **EP 1 286 367 B1**

(12) **EUROPEAN PATENT SPECIFICATION**

(45) Date of publication and mention of the grant of the patent:
09.12.2009 Bulletin 2009/50

(51) Int Cl.:
B66D 5/30 (2006.01) H01F 7/08 (2006.01)
H01F 41/06 (2006.01) H01F 27/24 (2006.01)

(21) Application number: **01914212.4**

(86) International application number:
PCT/JP2001/002351

(22) Date of filing: **23.03.2001**

(87) International publication number:
WO 2002/078020 (03.10.2002 Gazette 2002/40)

(54) **ELECTROMAGNET CORE, METHOD OF MANUFACTURING THE ELECTROMAGNET CORE, AND ELEVATOR HOIST BRAKE UTILIZING THE ELECTROMAGNET CORE**

ELEKTROMAGNETKERN, VERFAHREN ZU SEINER HERSTELLUNG UND ELEVATOR-HOIST-BREMSE MIT DEM ELEKTROMAGNETKERN

NOYAU ELECTROMAGNETIQUE, PROCEDE DE FABRICATION DE CE NOYAU ELECTROMAGNETIQUE, ET FREIN D'APPAREIL ELEVATEUR UTILISANT CE NOYAU ELECTROMAGNETIQUE

(84) Designated Contracting States:
DE NL

(43) Date of publication of application:
26.02.2003 Bulletin 2003/09

(73) Proprietor: **MITSUBISHI DENKI KABUSHIKI KAISHA**
Chiyoda-ku
Tokyo 100-8310 (JP)

(72) Inventors:
• **HOSHINOO, Tomokazu,**
Mitsubishi Denki K.K.
Chiyoda-ku, Tokyo 100-8310 (JP)

• **HORITA, Tsuyoshi,**
Mitsubishi Denki K.K.
Chiyoda-ku,
Tokyo 100-8310 (JP)

(74) Representative: **HOFFMANN EITLE**
Patent- und Rechtsanwälte
Arabellastrasse 4
81925 München (DE)

(56) References cited:
JP-A- 2 106 590 JP-A- 6 251 954
JP-A- 54 152 158 JP-A- 56 054 016

EP 1 286 367 B1

Note: Within nine months of the publication of the mention of the grant of the European patent in the European Patent Bulletin, any person may give notice to the European Patent Office of opposition to that patent, in accordance with the Implementing Regulations. Notice of opposition shall not be deemed to have been filed until the opposition fee has been paid. (Art. 99(1) European Patent Convention).

Description

TECHNICAL FIELD

[0001] The present invention relates to a core assembly of an electromagnet used in a brake for an hoisting machine of an elevator system. The core assembly of the electromagnet will hereinafter be referred to also as the electromagnet core assembly. An electromagnet core assembly according to the preamble of claim 1 is known from JP 56-054016.

BACKGROUND TECHNIQUES

[0002] A typical one of a hoisting machine for an elevator system in which an electromagnet core assembly is employed is shown in Fig. 4. More particularly, Fig. 4 shows a structure in general of a hitherto known hoisting machine for an elevator system which is equipped with a conventional electromagnet core assembly.

[0003] In Fig. 4, reference numeral 1 denotes an electromagnet core assembly, 2 denotes a coil and numeral 3 denotes a brake arm.

[0004] Figure 5 shows the electromagnet core assembly 1 of the elevator hoisting machine shown in Fig. 4. More specifically, Fig. 5 is an enlarged view showing schematically a conventional electromagnet core assembly 1 employed in the hoisting machine of an elevator.

[0005] The electromagnet core assembly 1 known heretofore is formed in an E-like fixed structure. As a consequence, an attempt to wind a coil around a mid or center projecting portion 10 by using a coil winding machine (coil winder) has failed because an arm of the coil winding machine interferes with side projecting portions 11 of the electromagnet core assembly 1, making it impossible to wind directly the coil around the center projecting portion 10.

[0006] Such being the circumstances, when the coil is to be mounted on and around the center projecting portion 10 of the electromagnet core assembly 1 by using the coil winding machine, the coil is previously wound once on a coil former dedicated to this end with the coil winding machine, whereon the coil thus formed is mounted on the center projecting portion 10 by inserting the latter into the coil.

[0007] Thus, with the conventional method of mounting the coil on the center projecting portion of the electromagnet core assembly, there are required two steps, i.e., winding of the coil on the coil former and mounting the coil formed around the center projecting portion of the electromagnet core assembly, giving rise to a problem from the viewpoint of the production efficiency, i.e., poor efficiency of manufacturing the electromagnet.

DISCLOSURE OF THE INVENTION

[0008] The present invention has been made with a view to solving the problem mentioned above, and it is

an object of the present invention to provide an improved electromagnetic core assembly which can ensure manufacturing of an electromagnet with an enhanced production efficiency by rendering unnecessary the step of mounting through insertion a coil on a center projecting portion of the electromagnet core assembly by allowing the coil to be directly wound around the center projecting portion.

[0009] For achieving the object mentioned above, in the electromagnet core assembly according to the present invention, movable core members are fit respectively between second laminated coil-wound core members (i.e., second core members laminated which are destined to be wound with a coil) by means of first engaging portions, respectively, first coil-wound core members (i.e., first core members which are destined to be wound with a coil together with the second core members) are respectively fit between the second laminated coil-wound core members by means of second engaging portions, respectively, the movable core members are rotatable about the first engaging portions, respectively, and a coil is wound around a coil-wound portion of the first and second coil-wound core members.

[0010] Further, in the electromagnet core assembly according to the present invention, the movable core members are fit between the second laminated coil-wound core members by means of the first engaging portions, respectively, and the first coil-wound core members are fit between the second laminated coil-wound core members by means of second engaging portions, respectively.

[0011] Furthermore, in the electromagnet core assembly according to the present invention, each of the second coil-wound core members is comprised of a base portion and a projecting portion integrally implemented substantially in a T-like shape, and the movable core members are mounted on the base portion at both ends thereof by means of the first engaging portions, respectively.

[0012] Moreover, in the electromagnet core assembly according to the present invention, each of the first coil-wound core members is comprised of a base portion and a projecting portion integrally implemented substantially in a T-like shape, and the projecting portion of the first coil-wound core member is formed in a shape which coincides with that of the projecting portion of the second coil-wound core member when the first coil-wound core member and the second coil-wound core member are stacked or superposed on each other.

[0013] In a method of manufacturing an electromagnet core assembly according to the present invention, a core subassembly is formed by fitting convex portions A of a second coil-wound core member in concave portions of movable core members, respectively, while fitting a convex portion B of the second coil-wound core member in a concave portion B of a first coil-wound core member, whereon a plurality of the core subassemblies are laminated one another by fitting convex portions B of the movable core members in the concave portions A of the sec-

ond coil-wound core members, respectively, while fitting convex portions B of the first coil-wound core members in the concave portions B of the second coil-wound core members, respectively, among the plurality of different core subassemblies, and a plurality of the first coil-wound core members and a plurality of the movable core members are sandwiched between a plurality of the second coil-wound core members, respectively, by fitting exposed convex portions of the movable core members in the concave portions A of the second coil-wound core members, respectively, while fitting exposed convex portions B of the first coil-wound core members in the concave portions B of the second coil-wound core members, respectively.

[0014] In a brake for a hoisting machine of an elevator system according to the present invention, the electromagnet core assembly described above is made use of.

BRIEF DESCRIPTION OF THE DRAWINGS

[0015]

Figure 1 is a block construction view showing an data collection apparatus according to an embodiment 1 of the present invention.

Figure 1 is a front side view showing an electromagnet core assembly according to an embodiment of the present invention.

Figure 2 shows a front side view and a top plan view of a second coil-wound core member according to the instant embodiment of the invention.

Figure 3 shows a front side view and a top plan view of a first coil winding portion according to the instant embodiment of the invention.

Figure 4 is a view showing generally a structure of an elevator hoisting machine equipped with an electromagnet core assembly known heretofore.

Figure 5 is an enlarged view of a conventional electromagnet core assembly 1 employed in the conventional hoisting machine of an elevator.

BEST MODES FOR CARRYING OUT THE INVENTION

[0016] In the following, the present invention will be elucidated in conjunction with an exemplary embodiment thereof.

[0017] Referring to Fig. 1, description will be made of an electromagnet core assembly according to an exemplary embodiment of the present invention. Figure 1 is a front side view showing an electromagnet core assembly according to the instant embodiment of the present invention.

[0018] In Fig. 1, reference numerals 20 denotes movable core members, respectively, 21 denotes a first coil-wound core member (i.e., a first core member to be wound with a coil) and 22 denotes a second coil-wound core member (i.e., a second core member to be wound with a coil). These core members are integrally assem-

bled together to constitute the electromagnet core assembly according to the instant embodiment.

[0019] Next, referring to Fig. 2, a structure of the second coil-wound core member shown in Fig. 1 will be described. Figure 2 is a front side view showing the second coil-wound core member according to the instant embodiment of the invention.

[0020] In Fig. 2, reference numeral 30 denotes a projecting portion which is intrinsically destined to be wound with a coil. Reference numeral 31 denotes a base portion which is provided with convex portions A and a convex portion B, respectively. More specifically, the convex portions A are formed at both sides of the base portion 31 while the convex portion B is formed substantially at a center or mid position of the base portion 31. These convex portions A and the convex portion B are formed on one surface of the second coil-wound coremember 22 implemented in the form of a substantially T-like plate. On the other hand, concave portions A and a concave portion B corresponding to the convex portions A and the convex portion B, respectively, are formed on the other or back surface of the second coil-wound core member 22.

[0021] Next, by reference to Fig. 3, a structure of the first coil-wound core member shown in Fig. 1 will be described in detail. Figure 3 is a front side view showing the first coil-wound core member according to the instant embodiment of the invention.

[0022] In Fig. 3, reference numeral 40 denotes a projecting portion which is intrinsically destined to be wound with the coil. Reference numeral 41 denotes a base portion which is provided with a convex portion B. This convex portion B is formed substantially at the a mid position of the base portion 31. More specifically, the convex portion B is formed on one surface of the first coil-wound core member 21 formed of a substantially T-like plate. On the other hand, a concave portion B corresponding to the convex portion B is formed on the other or back surface of the first coil-wound core member 21.

[0023] The convex portion B of the first coil-wound core member 21 is adapted to snugly engage with or fit in the concave portion B of the second coil-wound core member 22, while the convex portion B of the second coil-wound member 22 is adapted to snugly fit in or engage with the concave portion B of the first coil-wound core member 21. At this junction, it should be mentioned that the convex and concave portions B and B formed in the first and second coil-wound core members, respectively, are not necessarily provided at or in the vicinity of the mid position of the base portions 31 and 41. What is required is that the convex and concave portions B and B be provided so that the first and second coil-wound core members 21 and 22 can snugly engage or fit each other. Further, the number of the convex/concave portion is never limited to one, but two or more convex/ concave portions may equally be provided. It should additionally be mentioned that the length of the base portion 41 of the first coil-wound core member 21 is longer than that of the second

coil-wound core member 22.

[0024] On the other hand, each of the movable core members 20 is provided with a convex portion A at one end portion thereof. This convex portion A is formed on one surface of the movable core members 20 implemented in the form of a substantially I-like sheet or plate. A concave portions A corresponding to the convex portion A is formed in the back surface of the movable core members 20. The convex portion A of the movable core members 20 is adapted to snugly engage with or fit in the concave portions A of the second coil-wound core member 22. Further, the concave portions A of the movable core members 20 is adapted to snugly engage receive therein the convex portion A of the second coil-wound core member 22. When the movable core members 20 are juxtaposed with the first coil-wound core member 21, the magnet core assembly is realized substantially in an E-like structure. Further, it should be noted that in the state where the movable core members 20 are engaged with or fit in the second coil-wound core member 22 on which the first coil-wound core member 21 is mounted, the movable core members 20 can be rotated about the convex portions A, respectively.

[0025] For manufacturing the electromagnet core assembly according to the instant embodiment of the invention, the movable core members 20 are first superposed on the second coil-wound core member 22 so that the concave portions A of the movable core members 20 are engaged with or fit in the convex portions A, respectively, of the second coil-wound core member 22, and then the first coil-wound core member 21 is superposed on the second coil-wound core member 22 such that the convex portion B of the second coil-wound core member 22 is fit in the concave portion B of the first coil-wound core member 21, to thereby form a core subassembly. A plurality of the core subassemblies formed in this way are stacked or laminated with the convex portions A of the movable core members 20 of one core subassembly being fit in the concave portions A, respectively, of the second coil-wound core member 22 of another core subassembly while the convex portion B of the first coil-wound core member 21 of the one core subassembly is fit in the concave portion B of the second coil-wound core member 22 of the other core subassembly. Finally, the convex portions A of the movable core members 20 are fit in the concave portions A, respectively, of the second coil-wound core member 22 while the convex portion B of the first coil-wound core member 21 is fit in the concave portion B of the second coil-wound core member 22, whereby the stack or lamination of the first plural coil-wound members 21 and plural movable core members 20 are clamped together, being sandwiched between the second coil-wound core members 22. Thus, the electromagnet core assembly according to the instant embodiment of the invention is completed.

[0026] As can be understood from the above, the electromagnet core assembly according to the instant embodiment of the invention is manufactured by stacking or

laminating alternately the subassemblies of the movable core members 20 and the first coil-wound core member 21 on one hand and the second coil-wound core member 22 on the other hand, whereby the electromagnet core assembly can be implemented in a structure similar to that shown in Fig. 5. In the electromagnet core assembly completed, the individual movable core members 20 each sandwiched between the second coil-wound core members 22 can rotate about the convex portion A and the concave portions A formed in the second coil-wound core member 22. Incidentally, the convex portions A and the concave portions A of the movable core member 20 and the second coil-wound core member 22 constitute first engaging portions, respectively. Similarly, the convex portion B and the concave portion B of the first coil-wound core member 21 and the second coil-wound core member 22 cooperate to constitute a second engaging portion.

[0027] In this conjunction, it should be mentioned that it is not necessarily required to form both the convex portions A and the convex portion B in the one surface of the second coil-wound core member 22. To say in another way, a convex portion A and a concave portion B may be provided on the one surface of the second coil-wound core member 22. Furthermore, it is not always required to provide a pair of convex portions A in the one surface of the second coil-wound core member 22. To say in another way, a convex portion A and a concave portion A may be formed in the one surface of the second coil-wound core member 22 to thereby allow the two movable core members 20 to be undisplaceably but rotatably superposed on the second coil-wound core member 22, being seized by the convex portion A and the concave portions A, respectively. It is however important to ensure that the second coil-wound core members 22 on one hand and the movable core members 20 and the first coil-wound core member 21 on the other hand are stacked or laminated tightly.

[0028] Incidentally, the elevator hoisting machine which the present invention concerns can be implemented similarly to the structure generally shown in Fig. 4, description of which is omitted. Further, the outer appearance of the electromagnet core assembly according to the instant embodiment of the invention is approximately similar to that of the electromagnet core assembly shown in Fig. 5. Of course, the former assumes different outer appearance from the latter upon mounting the coil. Accordingly, the foregoing description has been made only of the features which differ from the conventional electromagnet core assembly.

[0029] As can now be understood from the foregoing, in the electromagnet core assembly according to the illustrated embodiment of the invention, it is possible to wind the coil around the projecting portion 30; 40 while avoiding interference between the movable core members 20 and the arm of the coil winding machine because the movable core members 20 can be unfolded or expanded upon winding of the coil around the projecting

portion 30; 40 with the coil winding machine. In other words, the coils can directly be wound on the core member by using an automatic coil winding machine.

[0030] Because the coil can directly be wound around the projecting portion 30; 40 with the coil winding machine, two steps of firstly forming the coil by using a coil former and secondly mounting the finished coil around the projecting portion through insertion as required in the conventional method can be reduced to one step of winding directly the coil around the projecting portion 30; 40, which can contribute to enhancing the production efficiency.

[0031] Besides, since the coil former dedicated heretofore for use for the coil winding can be spared the cost otherwise taken for the coil former can be reserved for the other purpose, to an advantage.

INDUSTRIAL APPLICABILITY

[0032] As is apparent from the foregoing, in the electromagnet core assembly according to the present invention, the movable core members are fit respectively between the second laminated coil-wound core members by means of the first engaging portions, respectively, while the first coil-wound core members are respectively fit between the second laminated coil-wound core members by means of the second engaging portions, respectively, allowing thus the movable core members being rotatable about the first engaging portions. By virtue of this structure, the coil can directly be wound around the coil-wound portion of the first and second coil-wound core members with the coil winding machine while avoiding interference between the movable core members and the arm of the coil winding machine because the movable core members can be unfolded or expanded upon winding of the coil around the first and second coil-wound core members because of rotatability of the movable core members. Because the coil can directly be wound around the first and second coil-wound core members with the coil winding machine in this manner, two steps of winding and insertion as required in the conventional method can be reduced to one step of winding directly the coil around the first and second coil-wound core members, which can contribute to enhancing the production efficiency.

Claims

1. An electromagnet core assembly, whereby

movable core members (20) are fit respectively between second laminated coil-wound core members (22) by means of first engaging portions (A, A), respectively, **characterized in that** first coil-wound core members (21) are respectively fit between said second laminated coil-wound core members (22) by means of second engaging portions (B, B), respectively,

said movable core members (20) are rotatable about said first engaging portions (A, A), respectively, and

that a coil is wound around a coil-wound portion (30; 40) of said first and second coil-wound core members (21; 22).

2. An electromagnet core assembly set forth in claim 1, **characterized in:**

that the movable core members (20) are fit between the second laminated coil-wound core members (22) by means of the first engaging portions (A, A), respectively, and the first coil-wound core members (21) are fit between said second laminated coil-wound core members (22) by means of second engaging portions (B, B), respectively.

3. An electromagnet core assembly set forth in claim 1 or 2, **characterized in:**

that each of said second coil-wound core members (22) is comprised of a base portion (31) and a projecting portion (30) integrally implemented substantially in a T-like shape, and **that** said movable core members (20) are mounted on said base portion (31) at both ends thereof by means of the first engaging portions (A, A), respectively.

4. An electromagnet core assembly set forth in at least of claims 1 to 3, **characterized in:**

that each of said first coil-wound core members (21) is comprised of a base portion (41) and a projecting portion (40) integrally implemented substantially in a T-like shape, and **that** the projecting portion (40) of said first coil-wound core member (21) is formed in a shape which coincides with that of the projecting portion (30) of the second coil-wound core member (22) when said first coil-wound core member (21) and said second coil-wound core member (22) are superposed on each other.

5. A method of manufacturing an electromagnet core assembly, **characterized in:**

that a core subassembly is formed by fitting convex portions A of a second coil-wound core member (22) in concave portions A of movable core members (20), respectively, while fitting a convex portion B of said second coil-wound core member (22) into a concave portion B of a first coil-wound core member (21), a plurality of said core subassemblies are laminated one another by fitting convex portions A

of said movable core members (20) in the concave portions A of said second coil-wound core members (22), respectively, while fitting convex portions B of said first coil-wound core members (21) in the concave portions B of said second coil-wound core members (22), respectively, among said plurality of different core subassemblies, and

that a plurality of the first coil-wound core members (21) and a plurality of the movable core members (20) are sandwiched between a plurality of second coil-wound core members (22), respectively, by fitting exposed convex portions A of said movable core members (20) in the concave portions A of the second coil-wound core members (22), respectively, while fitting exposed convex portions B of the first coil-wound core members (21) in the concave portions B of said second coil-wound core members (22), respectively.

6. A brake for a hoisting machine of an elevator system, **characterized in that** the electromagnet core assembly set forth in one of claims 1 to 4 is made use of.

Patentansprüche

1. Elektromagnetkernbauteil, bei dem bewegliche Kernelemente (20) entsprechend zwischen zweite geschichtete spulenbewickelte Kernelemente (22) mittels erster Eingriffsabschnitte (A, A) entsprechend eingepasst sind, **dadurch gekennzeichnet:**

dass erste spulenbewickelte Kernelemente (21) entsprechend zwischen die zweiten geschichteten spulenbewickelten Elemente (22) mittels der zweiten Eingriffsabschnitte (B, B) entsprechend eingepasst sind,

die beweglichen Kernelemente (20) um die ersten Eingriffsabschnitte (A, A) entsprechend drehbar sind, und

dass eine Spule um einen spulenbewickelten Abschnitt (30, 40) der ersten und zweiten spulenbewickelten Kernelemente (21, 22) gewickelt ist.

2. Elektromagnetkernbauteil gemäß Anspruch 1, **dadurch gekennzeichnet:**

dass die beweglichen Kernelemente (20) zwischen die zweiten geschichteten spulenbewickelten Kernelemente (22) mittels der ersten Eingriffsabschnitte (A, A) entsprechend eingepasst sind, und die ersten spulenbewickelten Kernelemente (22) mittels der zweiten Eingriffsabschnitte (B, B) entsprechend eingepasst sind.

3. Elektromagnetkernbauteil gemäß Anspruch 1 oder 2,

dadurch gekennzeichnet:

dass jedes der zweiten spulenbewickelten Kernelemente (22) aus einem Basisabschnitt (31) und einem Vorsprungabschnitt (30), die im Wesentlichen in einer T-artigen Gestalt integral implementiert sind, aufgebaut ist, und

dass die beweglichen Kernelemente (20) an einem Basisabschnitt (31) an beiden Seiten hiervon mittels der ersten Eingriffsabschnitte (A, A) entsprechend befestigt sind.

4. Elektromagnetkernbauteil gemäß einem der Ansprüche 1 bis 3, **dadurch gekennzeichnet:**

dass jede der ersten spulenbewickelten Kernelemente (21) aus einem Basisabschnitt (41) und einem Vorsprungabschnitt (40), die im Wesentlichen in einer T-artigen Gestalt integral implementiert sind, aufgebaut ist, und

dass der Vorsprungabschnitt (40) des spulenbewickelten Kernabschnitts (21) in einer Gestalt ausgebildet ist, die mit derjenigen des Vorsprungabschnitts (30) des zweiten spulenbewickelten Kernelements (22) übereinstimmt, wenn sich das erste spulenbewickelte Kernelement (21) und das zweite spulenbewickelte Kernelement (22) gegenseitig überlagern.

5. Verfahren zum Herstellen eines Elektromagnetkernbauteils, **dadurch gekennzeichnet, dass:**

ein Kernunterbauteil ausgebildet wird, indem konvexe Abschnitte A eines zweiten spulenbewickelten Bauteils (22) in konkave Abschnitten A der beweglichen Kernelemente (20) entsprechend eingepasst werden, während ein konvexer Abschnitt B des zweiten spulenbewickelten Kernelements (22) in einen konkaven Abschnitt B des ersten spulenbewickelten Elements (21) eingepasst wird,

eine Vielzahl der Kernunterbauteile zueinander geschichtet werden, indem konvexe Abschnitte A der beweglichen Kernabschnitte (20) entsprechend in die konkaven Abschnitte A der zweiten spulenbewickelten Kernelemente (22) eingepasst werden, während konvexe Abschnitte B der ersten spulenbewickelten Elemente (21) entsprechend in die konkaven Abschnitte B der zweiten spulenbewickelten Kernelemente (22) unter der Vielzahl der verschiedenen Kernunterbauteile eingepasst werden, und

dass eine Vielzahl der ersten spulenbewickelten Kernelemente (21) und eine Vielzahl der beweglichen Kernelemente entsprechend zwischen eine Vielzahl von zweiten spulenbewickelten

Kernelementen (22) eingelegt werden, indem freiliegende konvexe Abschnitte A der beweglichen Kernelemente (20) entsprechend in die konkaven Abschnitten A der zweiten spulenbewickelten Kernelemente (22) eingepasst werden, während die freiliegenden konvexen Abschnitte B der ersten spulenbewickelten Kernelemente entsprechend in die konkaven Abschnitte B der zweiten spulenbewickelten Kernelemente (22) eingepasst werden.

6. Bremse für eine Hebemaschine eines Aufzugsystems, **dadurch gekennzeichnet, dass** das Elektromagnetkernbauteil gemäß einem der Ansprüche 1 bis 4 verwendet wird.

Revendications

1. Ensemble formant noyau d'électroaimant, dans lequel des éléments formant noyaux mobiles (20) sont respectivement ajustés entre des seconds éléments formant noyaux stratifiés bobinés (22) respectivement au moyen de premières parties de mise en prise (A, A), **caractérisé en ce que :**

des premiers éléments formant noyaux bobinés (21) sont respectivement ajustés entre lesdits seconds éléments formant noyaux stratifiés bobinés (22) respectivement au moyen de secondes parties de mise en prise (B, B), lesdits éléments formant noyaux mobiles (20) sont rotatifs respectivement autour desdites premières parties de mise en prise (A, A), et une bobine est enroulée autour d'une partie bobinée (30 ; 40) desdits premiers et seconds éléments formant noyaux bobinés (21 ; 22).

2. Ensemble formant noyau d'électroaimant selon la revendication 1, **caractérisé en ce que :**

les éléments formant noyaux mobiles (20) sont ajustés entre les seconds éléments formant noyaux stratifiés bobinés (22) respectivement au moyen des premières parties de mise en prise (A, A), et les premiers éléments formant noyaux bobinés (21) sont ajustés entre lesdits seconds éléments formant noyaux stratifiés bobinés (22) respectivement au moyen de secondes parties de mise en prise (B, B).

3. Ensemble formant noyau d'électroaimant selon la revendication 1 ou 2, **caractérisé en ce que :**

chacun desdits seconds éléments formant noyaux bobinés (22) est composé d'une partie de base (31) et d'une partie en saillie (30) inté-

grée d'un seul tenant sensiblement en une forme semblable à un T, et lesdits éléments formant noyaux mobiles (20) sont montés sur ladite partie de base (31) au niveau des deux extrémités de cette dernière respectivement au moyen des premières parties de mise en prise (A, A).

4. Ensemble formant noyau d'électroaimant selon au moins une des revendications 1 à 3, **caractérisé en ce que :**

chacun desdits premiers éléments formant noyaux bobinés (21) est composé d'une partie de base (41) et d'une partie en saillie (40) intégrée d'un seul tenant sensiblement en une forme semblable à un T, et la partie en saillie (40) dudit premier élément formant noyau bobiné (21) est formée en une forme qui coïncide avec celle de la partie en saillie (30) du second élément formant noyau bobiné (22) lorsque ledit premier élément formant noyau bobiné (21) et ledit second élément formant noyau bobiné (22) sont superposés l'un sur l'autre.

5. Procédé pour fabriquer un ensemble formant noyau d'électroaimant, **caractérisé en ce que :**

un sous-ensemble de noyau est formé en ajustant des parties convexes A d'un second élément formant noyau bobiné (22) respectivement dans des parties concaves A d'éléments formant noyaux mobiles (20), tout en ajustant une partie convexe B dudit second élément formant noyau bobiné (22) dans une partie concave B d'un premier élément formant noyau bobiné (21),

une pluralité desdits sous-ensembles de noyau sont stratifiés les uns par rapport aux autres en ajustant des parties convexes A desdits éléments formant noyaux mobiles (20) respectivement dans les parties concaves A desdits seconds éléments formant noyaux bobinés (22), tout en ajustant des parties convexes B desdits premiers éléments formant noyaux bobinés (21) respectivement dans les parties concaves B desdits seconds éléments formant noyaux bobinés (22), parmi ladite pluralité de sous-ensembles de noyau différents, et

une pluralité des premiers éléments formant noyaux bobinés (21) et une pluralité des éléments formant noyaux mobiles (20) sont respectivement prises en sandwich entre une pluralité de seconds éléments formant noyaux bobinés (22), en ajustant des parties convexes exposées A desdits éléments formant noyaux mobiles (20) respectivement dans les parties concaves A des

seconds éléments formant noyaux bobinés (22), tout en ajustant des parties convexes exposées B des premiers éléments formant noyaux bobinés (21) respectivement dans les parties concaves B desdits seconds éléments formant noyaux bobinés (22). 5

6. Frein pour une machine de levage d'un système d'ascenseur, **caractérisé en ce que** l'ensemble formant noyau d'électroaimant selon l'une des revendications 1 à 4 est utilisé. 10

15

20

25

30

35

40

45

50

55

Fig. 1

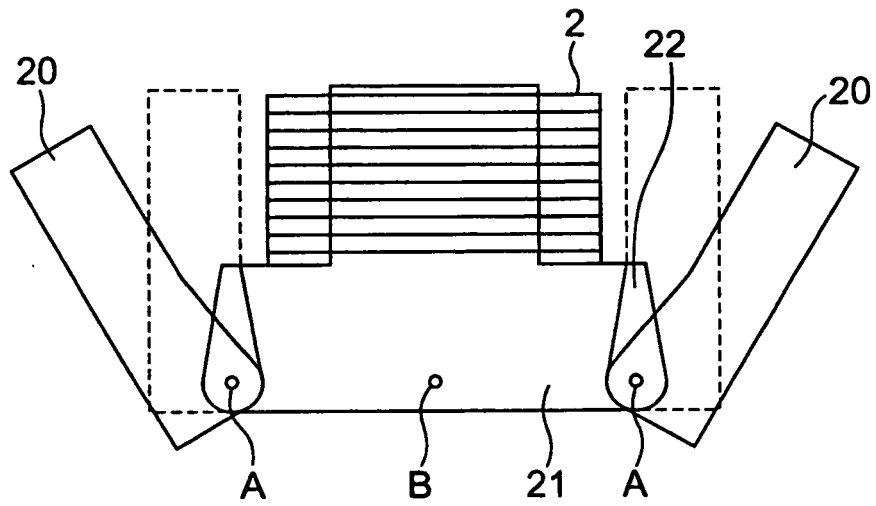

Fig. 2

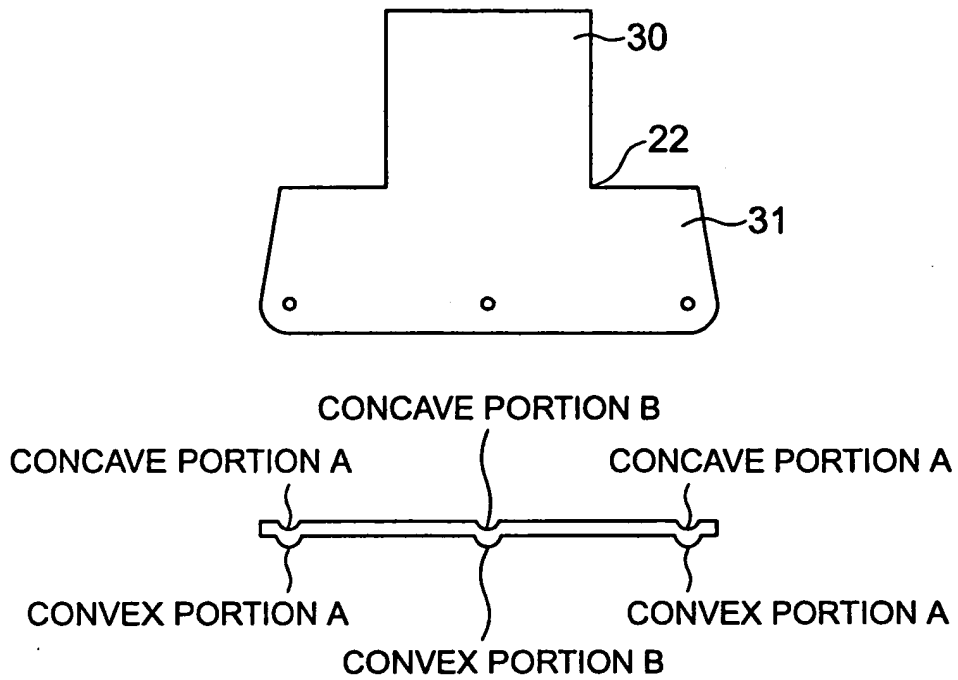

Fig. 3

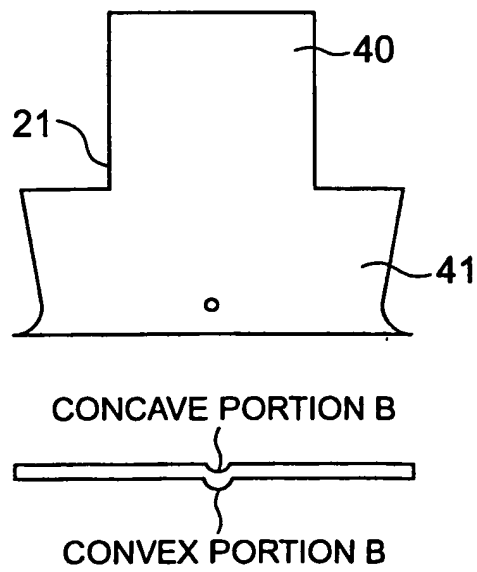

Fig. 4

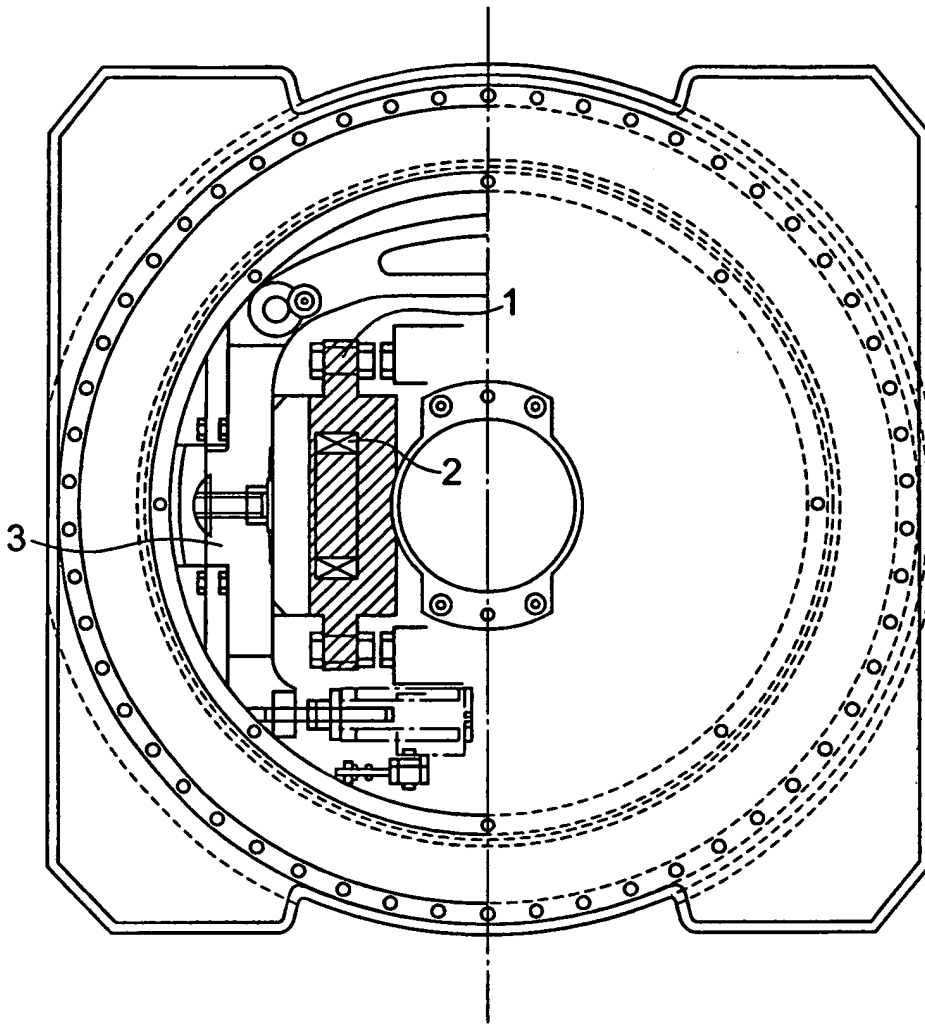
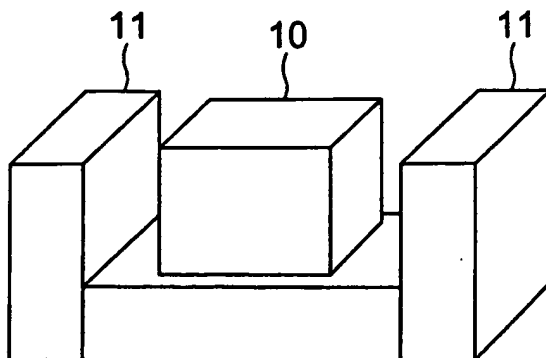

Fig. 5



REFERENCES CITED IN THE DESCRIPTION

This list of references cited by the applicant is for the reader's convenience only. It does not form part of the European patent document. Even though great care has been taken in compiling the references, errors or omissions cannot be excluded and the EPO disclaims all liability in this regard.

Patent documents cited in the description

- JP 56054016 A [0001]