



(11) **EP 1 288 025 B9**

(12) **CORRECTED EUROPEAN PATENT SPECIFICATION**

Note: Bibliography reflects the latest situation

(15) Correction information:  
**Corrected version no 1 (W1 B1)**  
**Corrections, see**  
**Description Paragraph(s) 2**

(51) Int Cl.:  
**B60C 29/00** (2006.01) **B60C 25/01** (2006.01)  
**B60C 25/132** (2006.01) **B60C 25/00** (2006.01)  
**B60S 5/04** (2006.01)

(48) Corrigendum issued on:  
**13.02.2008 Bulletin 2008/07**

(45) Date of publication and mention  
of the grant of the patent:  
**17.10.2007 Bulletin 2007/42**

(21) Application number: **02016988.4**

(22) Date of filing: **05.08.2002**

(54) **Safety device for pressurising an envelope at risk of bursting**

Sicherheitsvorrichtung zur Befüllung einer Hülle, die platzen kann

Dispositif de sécurité pour le gonflage d'une enveloppe présentant un risque d'éclatement

(84) Designated Contracting States:  
**AT BE BG CH CY CZ DE DK EE ES FI FR GB GR**  
**IE IT LI LU MC NL PT SE SK TR**

(30) Priority: **04.09.2001 IT VR20010095**

(43) Date of publication of application:  
**05.03.2003 Bulletin 2003/10**

(73) Proprietor: **BUTLER ENGINEERING &**  
**MARKETING SPA**  
**42010 Rio Saliceto (Reggio Emilia) (IT)**

(72) Inventor: **Gonzaga, Tullio**  
**42015 Correggio (Reggio Emilia) (IT)**

(74) Representative: **Reniero, Cirillo Silvano et al**  
**c/o Dr.Reniero & Associati S.r.l.**  
**Via D. Manin, 5**  
**37122 Verona (IT)**

(56) References cited:  
**US-A- 4 765 387** **US-A- 5 971 053**  
**US-B1- 6 173 751**

**EP 1 288 025 B9**

Note: Within nine months from the publication of the mention of the grant of the European patent, any person may give notice to the European Patent Office of opposition to the European patent granted. Notice of opposition shall be filed in a written reasoned statement. It shall not be deemed to have been filed until the opposition fee has been paid. (Art. 99(1) European Patent Convention).

## Description

**[0001]** The present invention relates to a safety device for pressurising an envelope at risk of bursting, particularly for inflating vehicle tires in general.

**[0002]** Such a device is for example known from US-A-6173751 which is regarded as being the closest prior art to the device of claim 1.

**[0003]** Normally the inflation of a tire after fitting onto a wheel-rim is carried out by placing the wheel onto a supporting platform (usually the rotating platform of a wheel fitting machine) and blowing compressed air into a tire through the suitable inflation valve.

**[0004]** As the pressures involved can be relatively high, if for any reason the tire burst, shreds of the tire and under extreme circumstances the wheel-rim itself would be thrown upwards, dramatically jeopardising the operator's safety.

**[0005]** Until now attempts have been made to limit such a risk by resorting to devices e.g. inflation cages. Inflation cages are themselves very effective devices, but they have the drawback to be rather cumbersome and difficult to use, as it is necessary to transfer the tire into a cage (usually manually, thus with a certain effort). The poor practicality of such devices and above all the inertia or laziness of the operator get him to give up using them as he should, with the practical result that he is often exposed to serious safety hazards.

**[0006]** The main object of the present invention is to provide a safety device for pressurising an envelope, typically a vehicle tire fitted onto a wheel-rim, that does not discourage the operator from using it for inflating any type of tire, thus ensuring his safety under any circumstance, if not for the fact that it is extremely handy and easy to manoeuvre.

**[0007]** Another object of the present invention is to have the said safety device operating as a verification instrument that makes it possible to obtain evidence that the same device was not actually used during inflation should a tire bursting take place.

**[0008]** A further object of the present invention is to provide a safety device for tire inflation that can be manufactured at very competitive production costs with respect to the costs of the safety devices currently being used.

**[0009]** These and other objects which will be better apparent below are attained according to the present invention by means of a safety device for pressurising an envelope at risk of bursting, comprising:

- a tubular body or cylinder;
- a piston element mounted slidably and sealably within at least one inner section of the said tubular body;
- a piston rod integral with the said piston and extending so as to protrude from a first end of the said tubular body;
- an annular bottom member arranged in the said tubular body at the said first end thereof and suitable

for slidably guiding the said piston rod and for closing the said tubular body, whereby delimiting an inner annular space together with the said piston;

- removable anchoring means suitable for acting at the protruding end of said piston rod and for constraining the said piston rod to a support;
- at least one inlet opening and at least one outlet opening formed in the said tubular body at the said annular space, the said inlet opening being arranged for being connected to a pressurised fluid source and the said outlet opening being arranged to be connected, in use, to the said envelope to be pressurised;
- yielding retention means for holding in position the said tubular body or cylinder so that in case of bursting, the unit formed by said tubular body and said annular bottom member can be moved longitudinally following a bursting impact with respect to the said piston, in contrast with the said yielding retention means.

**[0010]** Advantageously, the specific configuration of the safety device is such that, in operation, the said annular space contains pressurised air so that a cushioning effect is exerted against the upward thrust applied to the said cylinder following an accidental bursting of the envelope.

**[0011]** Further aspects and advantages of the present invention will be better apparent from the following detailed description of some specific currently preferred embodiments thereof, given by way of illustrating not limiting examples, and with reference to the accompanying drawings, in which:

- Figure 1 illustrates an elevation and longitudinal axial section view of a safety device according to the present invention in an idle or not operating configuration;
- Figure 2 shows an elevation and longitudinal axial section view of the safety device of Figure 1 in an operating configuration;
- Figures 3a and 3b are each a detail of Figures 1 and 2 on an enlarged scale having a different operating arrangement and, more particularly, Fig. 3a shows the safety device in an operating arrangement, whereas Fig. 3b illustrates the same device in a bursting configuration;
- Figure 4 shows a view similar to that of Fig. 1 but illustrating a safety device in an operating position for inflating a vehicle tire fitted onto a wheel-rim;
- Figure 5 shows a partial perspective view on an enlarged scale of a detail, i.e. of the retention means shown in Figure 4;
- Figure 6 illustrates a diametral cross section view of another embodiment of the safety device according to the present invention applied for inflating a vehicle tire fitted onto a wheel-rim;
- Figure 7 illustrates the retention means of the safety

- device of Figure 6 in its hooked arrangement;
- Figure 8 shows the retention means of Figure 6 in its releasing or disengagement configuration;
- Figure 9 is a view similar to that of Figure 5 but illustrating another embodiment of retaining means;
- Figures 10a and 10b each illustrate an elevation and longitudinal axial view of the retaining means of Figure 9;
- Figure 11 shows a detail on an enlarged scale of a variation of the retaining means.
- Figure 12 illustrates another variation of the holding means; and
- Figure 13 shows a partial cross section view of a further embodiment of the retaining means.

**[0012]** In the accompanying drawings the same or similar parts or components have been indicated by the same reference numerals.

**[0013]** With reference first to the embodiment shown in Figures 1 to 5, it will be noted that a safety device according to the present invention, generically indicated at 1, comprises a hollow cylindrical body or cylinder 2, preferably made of steel or light alloy, within which a piston 3 is slidably mounted, around which one or more annular grooves are formed for receiving a respective sealing gasket 4. Piston 3 is provided with a first piston rod 6, which extends so far as to protrude from a first end 5 of cylinder 2 and has a predetermined minimum length, as it will be further explained below. Piston rod 6 comprises two sections having a circular cross-section but different diameters: a first section 7 with a greater diameter is connected to piston 3, whereas the second section 8, with a smaller diameter, is connected to the first section 7, preferably through an intermediate frusto-conical portion 9.

**[0014]** An annular bottom member 11 (hereinafter termed bottom for expediency), advantageously provided with a flange 12, preferably outwardly covered with a soft material layer 12a, is inserted into cylinder 2 or somehow arranged in such a way as to close the light thereof at end 5. Bottom 11 has a through-hole 10, in which section 7 of piston rod 6 can sealably slide. Hole 10 is provided with one or more inner sealing gaskets 13, each of which is located in a respective annular groove peripherally formed in the hole 10.

**[0015]** At the free or distal end of section 8 of piston rod 6 an engagement member is provided, e.g. a cross pin 14, that is a component of the retaining means for providing a removable bayonet joint connection (as it is better shown in Figure 5) with a suitable slot 16, e.g. formed in a metal bracket 17 fixed to a support 18 (Fig. 4), that can be e.g. a rotating platform of a tire fitting machine (not shown in the drawings).

**[0016]** According to a structural variation, distal end 40 of piston rod 6 is threaded and designed to be screwed into a threaded hole 40a, e.g. formed in a block 40b (Fig. 11) inserted in the rotating platform 18 of a tire fitting machine .

**[0017]** If desired, the distal end 40 of the piston rod 6 has a threaded head hole 40c into which a threaded pin 40d can be screwed, that protrudes from the block 40b carried by the rotating platform 18 (Fig. 12) can be screwed.

**[0018]** The bottom 11 and piston 3 delimit an annular space 19 in the cylinder 2, at which at least one or more inlet openings 21 are formed, each of which being designed, in use, to be connected to a pressurised fluid source (not shown, e.g. a compressed air tank) through a suitable inlet duct 22, and one or more outlet openings 23 arranged to be connected through a suitable outlet duct 24 to an inflation valve, generally indicated at 24a in Fig. 4, provided on a tire 32 to be inflated (fitted onto a wheel-rim 20).

**[0019]** On the side opposite to the piston rod 6, piston 3 is provided with a second piston rod 26 that, in turn, extends so as to protrude through the other end 15 of the cylinder 2 to a sufficient extent to accomplish all the manoeuvres of the device, as it will be better apparent below. Piston rod 26 is advantageously thicker at its free end 29 so as to form a knob or handle and delimit an abutting shoulder 29a.

**[0020]** As it is better shown in Figs. 1 and 2, a helical spring 27 is also provided, which is wound around the protruding portion of the piston rod 26 and acts as a yielding retention means. More particularly, spring 27 can abut against a cross-member 28 fixed at the second end 15 of cylinder 2 (or directly against the end 15) and it is designed to react against the abutting shoulder 29a of knob 29.

**[0021]** According to another embodiment, not shown in the drawings, spring 27 can be seated within cylinder 2 where it is constrained to the stem 26 close to piston 3 on the one side, and to the cylinder 2 close to the end 15 thereof or to the cross-member 28, on the other side, in such a way as to operate in traction rather than in compression.

**[0022]** An annular yielding member 31 (hereafter termed "ring" for expediency) made of a plastically deformable material, when subjected to a sufficiently high threshold pressure is mounted on piston rod 6. In the shown embodiment, ring 31 has advantageously a "V" shaped cross-section and is preferably arranged in abutment onto the piston 3.

**[0023]** The above described safety device 1 operates in the following way.

**[0024]** A tire 32 to be inflated, previously fitted onto a wheel-rim 20, is positioned onto the rotating platform 18 of a tire fitting machine. The operator then proceeds by placing the flanged bottom member 11 onto the axial hole of wheel rim 20 with interposition of the soft layer 12a thereof to avoid damages such as scratches to the wheel-rim, and, while exerting a force onto knob 29 he compresses the spring 27 causing the piston rod 6 to extend out of cylinder 2 to such an extent that the distal end 40 of piston rod 6 with its respective pin 14 enters the slot 16 in order to bring the piston rod into engagement with

the bracket 17 beyond the slot 16. The piston rod 6 is then rotated through approximately 90° by acting on handle 29 to obtain a bayonet joint connection, as shown in Figure 5, after which spring 27 will maintain the necessary resilient load for keeping the rod-like unit 35 (comprising piston rod 6, piston 3 and piston rod 26) in traction.

**[0025]** The lengths of the sections 7 and 8 of piston rod 6 are such that, once the coupling between end 40 and bracket 17 has been completed, section 7 having a greater diameter than that of the piston rod 6 is moved to reach hole 10, and thus the annular space 19 is sealably closed at the hole 10 and inflation can take place.

**[0026]** The annular space 19 is then connected to the pressurised fluid source through a flexible duct 22 and to the inflation valve 24a of tire 32 through flexible conduct 24. The inflating operation can take place in a quick and quite easy way.

**[0027]** The safety device 1 therefore is responsible for both anchoring of the wheel-rim 20 to support 18 and the inflation of tire 32.

**[0028]** In case coupling between piston rod 6 and bracket 17 has failed, spring 27 causes piston rod 6 to be withdrawn in such a way that section 8 finds itself at the hole 10 formed in the bottom member 11, and thus the sealing fails, which means that space 19 leaks, but in any case there would be no risk of bursting.

**[0029]** In case of proper coupling and of an accidental pressure build-up that causes bursting of tire 32, wheel-rim 20 will tend to be lifted or in any case to be detached from platform 18.

**[0030]** The moving unit comprising wheel-rim 20, bottom member 11 and cylinder 2 is thus subjected to an abrupt displacement with respect to the rod-like assembly 35 (including piston 3 and piston rods 6 and 26), but such movement is contrasted by the joint action of spring 27 and compressed air inside annular space 19 that cushions and dampens the effect of the bursting impact and assists in holding tire 32 anchored against platform 18.

**[0031]** Should the tire 32 burst, ring 31 is compressed between piston 3 and bottom member 11, thus remaining permanently deformed, as shown in Fig. 3b, so that it acts as a reliable evidence proving whether safety device 1 has been used or not while carrying out the inflation of burst tire 32. If ring 31 results to be undamaged after bursting, that would mean that safety device 1 was not used in the inflation process.

**[0032]** Figures 6 to 8 illustrate a second embodiment of the present invention that essentially differs from the first embodiment in so far as the anchoring or retention system of piston rod 6 to support 18 is concerned. In this case, the rod-shaped assembly 35 has an axial through-cavity 36 into which a suitable control rod 37 that extends throughout the length of cavity 36 can be inserted and is preferably provided with a thickening or knob 38 outside the knob or proximal end 29.

**[0033]** The distal end 40 of hollow piston rod 6 has at least two side openings 33 acting as receiving seats for as many wings 39 articulated to the piston rod wall 6

about a respective transverse pin 45. Each wing 39 is substantially shaped as a bell-crank lever and comprises a first (short) portion 34 and a second (long) portion 35, the latter portion being arranged to be at an angle with respect to the former portion, and having substantially the same thickness as that of the hollow end wall 40 of piston rod 6 and at which the wing is hinged. The swivelling of the wings about their respective pivot pins 45 is limited on closing by contact between the short portion 34 and the tubular body of piston rod 6, and, on opening, when wings 39 end up abutting against one another at the free ends of portion 34 of each wing 39.

**[0034]** More particularly figure 7 shows end 40 of piston rod 6 completely inserted into bracket 17 and with wings 39 kept in an open configuration by a spring 41 fixed at one end thereof to the end 40 or to support 18 and acting against portion 34 of wings 39 at portion 34 of each wing 39.

**[0035]** Figure 8 shows the extraction or disengagement configuration or pattern of end 40 from bracket 17, where wings 39 are actuated to closure by inserting suitable control rod 37 into cavity 36 of the tubular structure of the rod-like assembly 35. The control rod 37 acts at its head against portion 34 of each wing 39 thereby causing it to be upturned inside its respective side opening 33, in contrast with the force of spring 41.

**[0036]** At this point it is possible to insert or extract piston rod 6 as wings 39 are contained within the encumbrance of piston rod 6.

**[0037]** It will be noted that in this embodiment, cross-sections that are even different from the circular cross-section can be adopted for tubular body 2 and for the elements forming the rod-like assembly 35.

**[0038]** Figures 9, 10a and 10b show another embodiment of the present invention, in which the retention or anchoring means to the support 18 is provided with a piston rod 6 having one outer diameter and arranged to sealably slide inside hole 10 of bottom 11. As illustrated in greater detail in Figures 10a and 10b, in lieu of bracket 17, a block 47 is provided in which a threaded blind hole 46 is formed, into whose bottom a seal 48 is seated, and in which one or more side vent holes 49 are provided. Piston rod 6 is inwardly hollow (cavity 42) and it communicates with annular space 19 through one or more side holes 43 formed close to piston 3. At its distal end, piston rod 6 has an outwardly threaded portion 44 designed to be screwed into threaded hole 46 of block 47 fixed (e.g. welded) to support 18.

**[0039]** Piston rod 6 must be tightly screwed into threaded hole 46 in order to exert the necessary pressure onto head seal 48, so that it sealably obstructs passage for the compressed air contained in inner cavity 42 of piston rod 6, which is in communication with space 19. In case tight screwing of stem 6 fails, compressed air 6 from inner annular space 19 flows through inner cavity 42 of piston rod 6 and comes out through side vent duct or ducts 49 formed in the seat 47, thus preventing tire 32 from being inflated.

[0040] Of course, in this embodiment piston rod 6, piston 3 and the tubular body 2 are necessarily cylindrical in shape.

[0041] According to another embodiment, end tip 40 of hollow piston rod 6 can have an end inner threading section designed to be screwed onto a pin that is integral with support 18 and protruding therefrom, about which an annular seal 48 is arranged for abutment of piston rod 6 (Fig. 12).

[0042] According to another embodiment shown in Figure 13, a bayonet joint connection between hollow piston rod 6 and bracket 17 can be provided. From a constructional viewpoint, end 40 of stem 6 is provided with a cross-head suitable for passing through slot 16 (as in Figure 5) but on the opposite side it is provided with one or more side ducts or vent holes 49 leading to support bracket 17 at one or more seals 49a located in a suitable seat formed in the bracket 17, whereby ensuring that sealing is accomplished only when the said cross-head is abutting against seals 49a.

[0043] Any reference sign following technical features in any claim has been provided to increase intelligibility of the claim and shall not be construed as limiting the scope of the claim.

## Claims

1. A safety device for inflating an envelope (32) at risk of bursting comprising:
  - a tubular body (2);
  - a piston element (3) slidably and sealably mounted within at least one inner section of the said tubular body (2);
  - a piston rod (6) integral with said piston (3) and extending so as to protrude from a first end (5) of the said tubular body (2);
  - an annular bottom member (11), arranged in the said tubular body (2) or at the first end thereof (5) thereof and suitable for slidably guiding the said piston rod (6) and for closing the said tubular body (2), whereby delimiting an annular space (19) together with the said piston (3);
  - removable anchoring means (14; 39; 44) for acting at the protruding end of said piston rod (6) and for constraining the said piston rod (6) to a support (18);
  - at least one inlet opening (21) and at least one outlet opening (23) formed in the said tubular body (2) at the said annular space (19), the said inlet opening (21) being suitable for being connected to a pressurised fluid source and the said outlet opening (23) being arranged to be connected, in use, to the said envelope to be pressurised (32) ; and
  - yielding retention means (19, 27) for holding in position said body (2) and said annular bottom

member (11), so that in case of bursting, the unit formed by said tubular body (2) and said annular bottom member (11), can be moved longitudinally following a bursting impact with respect to the said piston element (3) in contrast with the said yielding retention means (19, 27).

2. A device according to Claim 1, **characterised in that** the said piston rod (6) comprises a first section (7) having a greater diameter and arranged adjacent to the said piston element (3), and a second section (8) having a smaller diameter, the said first section (7) being arranged to sealably slide through said bottom (11), whereby ensuring the sealing of said ring-shaped space (19) when the said second section (8) has protruded out of the said bottom (11) to a sufficient extent.
3. A device according to Claim 2, **characterised in that** between the said first section (7) and the said second section (8) of the said piston rod (6) a substantially frusto-conical intermediate section (9) is provided.
4. A device according to any claim 1 to 3, **characterised in that** the said piston rod (6) is hollow and has at least one opening (43) communicating with the said annular space (19) close to the said piston element (3) and **in that** it comprises a receiving seat for locating the said piston rod (6), provided with a seal (48) against which said piston rod (6) sealably abuts when the said piston rod (6) is engaged with the said support (18).
5. A device according to any Claim 2 to 4, **characterised in that** the said anchoring means comprises at least a male member (14) or a female opening on the said piston rod (6) and a female member (16) or a male object on the said support (18), so as to make it possible to obtain a bayonet joint connection.
6. A device according to any Claim 1 to 4, **characterised in that** the said anchoring means comprises a threaded end portion (44) of the said piston rod (6) and a threading (46) in or on a screwing member (47) for the said threaded end portion (44) integral with the said support (18).
7. A device according to Claim 6, **characterised in that** the said screwing member (47) comprises at least a vent duct (49).
8. A device according to Claim 6 **characterised in that** the said end portion (44) is outwardly threaded.
9. A device according to claim 6, **characterised in that** the said piston rod (6) is formed with a threaded end hole suitable for being screwed onto a threaded pin

protruding from the said support (18).

10. A device according to claim 5, **characterised in that** the said male element (14) of the said piston rod (6) comprises at least a side duct leading, on the opposite side, to the said support (18) at the said at least one seal (48), and a bracket (17) integral with the said support (18), in which a seat is formed for receiving each seal (48), thereby ensuring the sealing only when the said male element (14) is abutting against the or each seal (49a).
11. A device according to any claim 4 and 6 or 7, **characterised in that** it comprises a block element (47) fixed to the said support (18) and being formed with a hole in which the said threading (46) is obtained and **in that** the said hole communicates with the said vent ducts (49), so that sealing is ensured only when the said male element (14) abuts against the or each seal (48).
12. A device according to claims 4 and 6, **characterised in that** the said end portion (44) has a threaded end hole (40c) and **in that** the said threading (40b) is formed on a pin (40d) protruding from the said support (18) around which the said seal (48) is located, so that sealing is ensured only when the said end portion (44) abuts against the said at least one seal (48).
13. A device according to claim 2 or 3, **characterised in that** it comprises an uninterrupted longitudinal cavity (36), delimited by the said first piston rod (6) and the said piston element (3), a control rod (37) at least coextending with the said cavity (36), slidably mounted within the said cavity and protruding out of the said piston element (3), a receiving opening for said distal end (40) of the said piston rod (6) formed in the said support (18) and expansible anchoring means (39) designed to be controlled by the said control rod (37) and arranged at the said end (40).
14. A device according to any preceding claim, **characterised in that** it comprises a second piston rod (26) extending from the said piston element (3) on the side opposite to the said first piston rod (6).
15. A device according to Claim 14, **characterised in that** the said second piston rod (26) is outwardly provided with manual actuation means (29) for said tubular body (2).
16. A device according to Claim 14 or 15, **characterised in that** it comprises an uninterrupted longitudinal cavity (36), delimited by the said first piston rod (6), said piston element (3), and said second piston rod (26), a control rod (37), at least coextensive with the said cavity (36), slidably mounted therewithin and

5

10

15

20

25

30

35

40

45

50

55

protruding out of said second piston rod (26), an opening for receiving said distal end (40) of the said piston rod (6) formed in the said support (18) and expansible anchoring means (39) controlled by said control rod (37) and arranged at the said end (40).

17. A device according to any preceding Claim, **characterised in that** the said yielding retention means comprises compressed air contained in said inner annular space (19).
18. A device according to any preceding Claim, **characterised in that** the said yielding retention means comprises resilient retention means (27).
19. A device according to Claim 18, **characterised in that** the said resilient means comprises a helical spring (27) arranged around said second piston rod (26) and suitable for acting between the said second piston rod (26) and the said tubular body (2).
20. A device according to Claim 18, **characterised in that** the said resilient retention means comprises a helical spring (27) arranged around the said second piston rod (26), inside the said tubular body (2) and, on the one side, constrained to it and, on the other, to the said second piston rod (26) or to the said piston element (3), so as to operate in traction.
21. A device according to any Claim 18 to 20, **characterised in that** the said resilient retention means (27) acts as resilient loading means.
22. A device according to any preceding Claim, **characterised in that** it comprises a witness memory element (31) mounted onto the said first piston rod (6) close to the said piston element (3) and made of a plastically deformable material which becomes deformed upon an impact beyond a predetermined pressure threshold.
23. A device according to any preceding Claim, **characterised in that** the said bottom (11) is arranged at the said first end (5) of the said tubular body (2) and has a flange (12) acting as a support and abutment.

#### Patentansprüche

1. Sicherheitsvorrichtung zur Befüllung einer Hülle (32), die platzen kann, mit
- einem rohrförmigen Körper (2);
  - einem Kolbenelement (3), das gleitbar und abdichtend in mindestens einem inneren Abschnitt des rohrförmigen Körpers (2) eingesetzt ist;
  - einer Kolbenstange (6), die integral mit dem Kolben (3) ist und sich so erstreckt, um aus ei-

- nem ersten Ende (5) des rohrförmigen Körpers (2) herauszuragen ;  
 - einem ringförmigen Bodenelement (11), das in dem rohrförmigen Körper (2) oder an einem ersten Ende (5) dessen angeordnet ist und geeignet ist, die Kolbenstange (6) gleitend zu führen und den rohrförmigen Körper (2) zu schließen, wobei es zusammen mit dem Kolben (3) einen ringförmigen Raum (19) begrenzt ;  
 - abnehmbaren Verankerungseinrichtungen (14; 39; 44), um an dem herausragenden Ende der Kolbenstange (6) zu wirken und die Kolbenstange (6) an einem Träger (18) zu halten;  
 - mindestens einer Einlaßöffnung (21) und mindestens einer Auslaßöffnung (23), die in dem rohrförmigen Körper (2) an dem ringförmigen Raum (19) gebildet sind, wobei die Einlaßöffnung (21) geeignet ist, um mit einer unter Druck stehenden Fluidquelle verbunden zu werden, und die Auslaßöffnung (23) eingerichtet ist, um in Gebrauch mit der unter Druck zu setzenden Hülle (32) verbunden zu werden; und  
 - nachgebenden Halteeinrichtungen (19, 27) zum Halten des Körpers (2) und des ringförmigen Bodenelements (11) in Position, so daß im Falle eines Platzens die aus dem rohrförmigen Element (2) und dem ringförmigen Bodenelement (11) gebildete Einheit, einem Stoß des Platzens folgend, längs bezüglich des Kolbenelements (3) im Gegensatz zu den nachgebenden Halteeinrichtungen (19, 27) bewegt werden kann.
2. Vorrichtung nach Anspruch 1, **dadurch gekennzeichnet, daß** die Kolbenstange (6) einen ersten Abschnitt (7) aufweist, der einen größeren Durchmesser hat und angrenzend an das Kolbenelement (3) angeordnet ist, und einen zweiten Abschnitt (8) aufweist, der einen kleineren Durchmesser hat, wobei der erste Abschnitt (7) angeordnet ist, um abdichtend durch den Boden (11) zu gleiten und **dadurch** die Abdichtung des ringförmigen Raums (19) sicherzustellen, sobald der zweite Abschnitt (8) in einem ausreichenden Maß aus dem Boden (11) herausragt.
3. Vorrichtung nach Anspruch 2, **dadurch gekennzeichnet, daß** zwischen dem ersten Abschnitt (7) und dem zweiten Abschnitt (8) der Kolbenstange (6) ein im wesentlichen kegelstumpfförmiger Zwischenabschnitt (9) bereitgestellt ist.
4. Vorrichtung nach einem der Ansprüche 1 bis 3, **dadurch gekennzeichnet, daß** die Kolbenstange (6) hohl ist und nahe an dem Kolbenelement (3) mindestens eine Öffnung (43) hat, die mit dem ringförmigen Raum (19) in Verbindung steht, und **dadurch**, daß sie einen Aufnahmesitz zum Anordnen der Kolbenstange (6) aufweist, der mit einer Dichtung (48) versehen ist, an welcher die Kolbenstange (6) abdichtend anliegt, wenn die Kolbenstange (6) mit dem Träger (18) im Eingriff ist.
5. Vorrichtung nach einem der Ansprüche 2 bis 4, **dadurch gekennzeichnet, daß** die Verankerungseinrichtung mindestens ein männliches Element (14) oder eine weibliche Öffnung an der Kolbenstange (6) und ein weibliches Element (16) oder ein männliches Objekt an dem Träger (18) aufweist, um so zu ermöglichen, eine Bajonettverschlußverbindung herzustellen.
6. Vorrichtung nach einem der Ansprüche 1 bis 4, **dadurch gekennzeichnet, daß** die Verankerungseinrichtung einen mit Gewinde versehenen Endabschnitt (44) der Kolbenstange (6) und in oder an einem mit dem Träger (18) integralen Schraubelement (47) ein Gewinde (46) für den mit Gewinde versehenen Endabschnitt (44) aufweist.
7. Vorrichtung nach Anspruch 6, **dadurch gekennzeichnet, daß** das Schraubelement (47) mindestens einen Entlüftungskanal (49) aufweist.
8. Vorrichtung nach Anspruch 6, **dadurch gekennzeichnet, daß** der Endabschnitt (44) außen mit Gewinde versehen ist.
9. Vorrichtung nach Anspruch 6, **dadurch gekennzeichnet, daß** die Kolbenstange (6) mit einem mit Gewinde versehenen Endloch versehen ist, das geeignet ist, um auf einen mit Gewinde versehenen Dorn, der aus dem Träger (18) vorspringt, geschraubt zu werden.
10. Vorrichtung nach Anspruch 5, **dadurch gekennzeichnet, daß** das männliche Element (14) der Kolbenstange (6) mindestens einen Seitenkanal aufweist, der an der gegenüberliegenden Seite zu dem Träger (18) an der mindestens einen Dichtung (48) und zu einer mit dem Träger (18) integralen Klammer (17) führt, in welcher ein Sitz zur Aufnahme jeder Dichtung (48) gebildet ist, wodurch die Abdichtung nur dann erreicht wird, wenn das männliche Element (14) an der oder jeder Dichtung (49a) anliegt.
11. Vorrichtung nach einem der Ansprüche 4 und 6 oder 7, **dadurch gekennzeichnet, daß** sie ein Blockelement (47) aufweist, das an dem Träger (18) befestigt ist und mit einem Loch versehen ist, in welchem das Gewinde (46) angeordnet ist, und **dadurch**, daß das Loch mit den Entlüftungskanälen (49) in Verbindung steht, so daß eine Abdichtung nur dann erreicht wird, wenn das männliche Element (14) an der oder an jeder Dichtung (48) anliegt.

12. Vorrichtung nach Anspruch 4 und Anspruch 6, **dadurch gekennzeichnet, daß** der Endabschnitt (44) ein mit Gewinde versehenes Endloch (40c) hat, und **dadurch**, daß das Gewinde (40b) an einem aus dem Träger (18) vorspringenden Dorn (40d) gebildet ist, um welchen die Dichtung (48) angeordnet ist, so daß eine Abdichtung nur dann erreicht wird, wenn der Endabschnitt (44) an der mindestens einen Dichtung (48) anliegt.

13. Vorrichtung nach Anspruch 2 oder 3, **dadurch gekennzeichnet, daß** sie aufweist :

einen sich längs erstreckenden kontinuierlichen Hohlraum (36), der von der ersten Kolbenstange (6) und dem Kolbenelement (3) begrenzt wird, eine sich mindestens gemeinsam mit dem Hohlraum (36) erstreckende Steuerstange (37), die gleitbar in dem Hohlraum eingesetzt ist und aus dem Kolbenelement (3) herausragt, eine in dem Träger (18) gebildete Aufnahmeöffnung für das distale Ende (40) der Kolbenstange (6), und ausfahrbare Verankerungseinrichtungen (39), die vorgesehen sind, um von der Steuerstange (37) gesteuert zu werden und an dem Ende (40) angeordnet sind.

14. Vorrichtung nach einem der vorstehenden Ansprüche, **dadurch gekennzeichnet, daß** sie eine zweite Kolbenstange (26) aufweist, die sich an der Seite, die der ersten Kolbenstange (6) gegenüberliegt, von dem Kolbenelement (3) aus erstreckt.

15. Vorrichtung nach Anspruch 14, **dadurch gekennzeichnet, daß** die zweite Kolbenstange (26) außen mit manuellen Betätigungseinrichtungen (29) für den rohrförmigen Körper (2) versehen ist.

16. Vorrichtung nach Anspruch 14 oder 15, **dadurch gekennzeichnet, daß** sie aufweist:

einen sich längs erstreckenden kontinuierlichen Hohlraum (36), der von der ersten Kolbenstange (6), dem Kolbenelement (3) und der zweiten Kolbenstange (26) begrenzt wird, eine sich mindestens gemeinsam mit dem Hohlraum (36) erstreckende Steuerstange (37), die gleitbar in dem Hohlraum eingesetzt ist und aus der zweiten Kolbenstange (26) herausragt, eine in dem Träger (18) gebildete Öffnung zur Aufnahme des distalen Endes (40) der Kolbenstange (6), und ausfahrbare Verankerungseinrichtungen (39), die von der Steuerstange (37) gesteuert werden und an dem Ende (40) angeordnet sind.

17. Vorrichtung nach einem der vorstehenden Ansprü-

che, **dadurch gekennzeichnet, daß** die nachgebende Halteeinrichtung in dem inneren ringförmigen Raum (19) enthaltene Druckluft aufweist.

18. Vorrichtung nach einem der vorstehenden Ansprüche, **dadurch gekennzeichnet, daß** die nachgebende Halteeinrichtung elastische Halteeinrichtungen (27) aufweist.

19. Vorrichtung nach Anspruch 18, **dadurch gekennzeichnet, daß** die elastische Einrichtung eine Schraubenfeder (27) aufweist, die um die zweite Kolbenstange (26) herum angeordnet ist und geeignet ist, um zwischen der zweiten Kolbenstange (26) und dem rohrförmigen Körper (2) zu wirken.

20. Vorrichtung nach Anspruch 18, **dadurch gekennzeichnet, daß** die elastischen Halteeinrichtung eine Schraubenfeder (27) aufweist, die um die zweite Kolbenstange (26) herum innerhalb des rohrförmigen Körpers (2) angeordnet ist, und an der einen Seite mit ihm eingespannt und an der anderen Seite mit der zweiten Kolbenstange (26) oder dem Kolbenelement (3) eingespannt ist, um so auf Zug zu arbeiten.

21. Vorrichtung nach einem der Ansprüche 18 bis 20, **dadurch gekennzeichnet, daß** die elastische Halteeinrichtung (27) als eine elastische Ladeeinrichtung wirkt.

22. Vorrichtung nach einem der vorstehenden Ansprüche, **dadurch gekennzeichnet, daß** sie ein Beweisspeicherelement (31) aufweist, das an der ersten Kolbenstange (6) nahe an dem Kolbenelement (3) angebracht ist und aus einem plastisch verformbaren Material besteht, das bei einem Stoß jenseits eines vorgegebenen Druckschwellenwerts verformt wird.

23. Vorrichtung nach einem der vorstehenden Ansprüche, **dadurch gekennzeichnet, daß** der Boden (11) an dem ersten Ende (5) des rohrförmigen Körpers (2) angeordnet ist und einen Flansch (12) aufweist, der als ein Träger und Widerlager wirkt.

## Revendications

1. Dispositif de sécurité pour le gonflage d'une enveloppe (32) présentant un risque d'éclatement comprenant:

un corps tubulaire (2);  
un élément à piston (3) monté pour coulisser de manière étanche à l'intérieur d'au moins une partie intérieure dudit corps tubulaire (2);  
une tige de piston (6) solidaire dudit piston (3) et s'étendant en formant une saillie depuis une

- première extrémité (5) dudit corps tubulaire (2) ; un élément annulaire (11) de partie inférieure disposé dans ledit corps tubulaire (2) ou au niveau de la première extrémité (5) de celui-ci et qui permet de guider en la faisant coulisser ladite tige de piston (6) et de fermer ledit corps tubulaire (2), délimitant ainsi un espace annulaire (19) conjointement avec ledit piston (3) ; un moyen d'ancrage amovible (14 ; 39 44) agissant à l'extrémité formant saillie de ladite tige de piston (6) et permettant de contraindre ladite tige de piston (6) à un support (18) ; au moins une ouverture d'entrée (21) et au moins une ouverture de sortie (23) formées dans ledit corps tubulaire (2) au niveau dudit espace annulaire (19), ladite ouverture d'entrée (21) étant prévue pour être reliée à une source de fluide sous pression et ladite ouverture de sortie (23) étant agencée pour être reliée, en utilisation, à ladite enveloppe à mettre sous pression (32) ; et un moyen de rétention élastique (19, 27) permettant de maintenir en position ledit corps (2) et ledit élément annulaire (11) de partie inférieure de façon à ce qu'en cas d'éclatement, l'ensemble formé par ledit corps tubulaire (2) et ledit élément annulaire (11) de partie inférieure puisse, à la suite d'un choc par éclatement, se déplacer longitudinalement par rapport audit élément à piston (3) au contraire dudit moyen de rétention élastique (19, 27).
2. Dispositif selon la revendication 1, **caractérisé en ce que** ladite tige de piston (6) comprend une première partie (7) de grand diamètre qui est disposée en étant adjacente audit élément à piston (3), et une deuxième partie (8) de petit diamètre, ladite première partie (7) étant agencée pour coulisser de manière étanche par rapport à ladite partie inférieure (11), ce qui assure l'étanchéité dudit espace (19) de forme annulaire lorsque ladite deuxième partie (8) a fait saillie de ladite partie inférieure (11) sur une étendue suffisante.
3. Dispositif selon la revendication 2, **caractérisé en ce qu'**entre ladite première partie (7) et ladite deuxième partie (8) de ladite tige de piston (6), une partie intermédiaire (9) de forme sensiblement tronconique est fournie.
4. Dispositif selon l'une quelconque des revendications 1 à 3, **caractérisé en ce que** ladite tige de piston (6) est creuse et possède au moins une ouverture (43) qui communique avec ledit espace annulaire (19) situé à proximité dudit élément à piston (3), et **en ce qu'**il comprend un siège récepteur pour positionner ladite tige de piston (6), qui est muni d'une garniture d'étanchéité (48) contre laquelle ladite tige de piston (6) bute de manière étanche lorsque la tige de piston (6) s'engage avec ledit support (18).
5. Dispositif selon l'une quelconque des revendications 2 à 4, **caractérisé en ce que** ledit moyen d'ancrage comprend au moins un élément mâle (14) ou une ouverture femelle sur ladite tige de piston (6) et un élément femelle (16) ou un élément mâle sur ledit support (18), de manière à pouvoir obtenir une liaison à accouplement par baïonnette.
6. Dispositif selon l'une quelconque des revendications 1 à 4, **caractérisé en ce que** ledit moyen d'ancrage comprend une partie d'extrémité filetée (44) de ladite tige de piston (6) et un taraudage (46) pratiqué dans ou sur un élément à visser (47) de ladite partie d'extrémité filetée (44) qui est formé solidaire avec ledit support (18).
7. Dispositif selon la revendication 6, **caractérisé en ce que** ledit élément à visser (47) comprend au moins un conduit d'évacuation (49).
8. Dispositif selon la revendication 6, **caractérisé en ce que** ladite partie d'extrémité (44) est filetée extérieurement.
9. Dispositif selon la revendication 6, **caractérisé en ce que** ladite tige de piston (6) est formée avec un trou d'extrémité taraudé dans lequel peut être vissée une goupille filetée qui fait saillie dudit support (18).
10. Dispositif selon la revendication 5, **caractérisé en ce que** ledit élément mâle (14) de ladite tige de piston (6) comprend au moins un conduit latéral conduisant, du côté opposé, audit support (18) au niveau de ladite au moins une garniture d'étanchéité (48), et une patte d'attache (17) formée solidaire avec ledit support (18), dans laquelle est formé un siège pour recevoir chaque garniture d'étanchéité (48), ce qui n'assure l'étanchéité que lorsque ledit élément mâle (14) est en butée contre la ou chaque garniture d'étanchéité (49a).
11. Dispositif selon l'une quelconque des revendications 4 et 6 ou 7, **caractérisé en ce qu'**il comprend un élément bloc (47) fixé audit support (18) et constitué d'un trou dans lequel ledit taraudage (46) est obtenu et **en ce que** ledit trou communique avec lesdits conduits d'évacuation (49), de sorte que l'étanchéité n'est obtenue que lorsque ledit élément mâle (14) bute contre la ou chaque garniture d'étanchéité (48).
12. Dispositif selon les revendications 4 et 6, **caractérisé en ce que** ladite partie d'extrémité (44) possède un trou d'extrémité taraudé (40c) et **en ce que** ledit filet (40b) est formé sur une goupille (40d) saillante dudit support (18) autour duquel ladite garniture

d'étanchéité (48) est située, de sorte que l'étanchéité n'est obtenue que lorsque ladite partie d'extrémité (44) bute contre ladite au moins une garniture d'étanchéité (48).

13. Dispositif selon la revendication 2 ou 3, **caractérisé en ce qu'il** comprend une cavité longitudinale ininterrompue (36) délimitée par ladite première tige de piston (6) et par ledit élément à piston (3), une tige de commande (37) s'étendant au moins conjointement avec ladite cavité (36), montée de manière coulissante à l'intérieur de ladite cavité et faisant saillie dudit élément à piston (3), une ouverture de réception pour ladite extrémité distale (40) de ladite tige de piston (6) formée dans ledit support (18) et un moyen d'ancrage expansible (39) prévu pour être commandé par ladite tige de commande (37) et disposé au niveau de ladite extrémité (40).
14. Dispositif selon l'une quelconque des revendications précédentes, **caractérisé en ce qu'il** comprend une deuxième tige de piston (26) s'étendant depuis ledit élément à piston (3) du côté opposé à ladite tige de piston (6).
15. Dispositif selon la revendication 14, **caractérisé en ce que** ladite deuxième tige de piston (26) est munie extérieurement d'un moyen d'actionnement manuel (29) dudit corps tubulaire (2).
16. Dispositif selon la revendication 14 ou 15, **caractérisé en ce qu'il** comprend une cavité longitudinale ininterrompue (36) délimitée par ladite première tige de piston (6), ledit élément à piston (3), et ladite deuxième tige de piston (26), une tige de commande (37) s'étendant au moins conjointement avec ladite cavité (36), montée de manière coulissante dans celle-ci et faisant saillie de ladite deuxième tige de piston (26), une ouverture pour recevoir ladite extrémité distale (40) de ladite tige de piston (6) formée dans ledit support (18) et un moyen d'ancrage expansible (39) commandé par ladite tige de commande (37) et disposé au niveau de ladite extrémité (40).
17. Dispositif selon l'une quelconque des revendications précédentes, **caractérisé en ce que** ledit moyen de rétention élastique comprend de l'air comprimé contenu dans ledit espace annulaire intérieur (19).
18. Dispositif selon l'une quelconque des revendications précédentes, **caractérisé en ce que** ledit moyen de rétention élastique comprend un moyen de rétention résilient (27).
19. Dispositif selon la revendication 18, **caractérisé en ce que** ledit moyen résilient comprend un ressort hélicoïdal (27) disposé autour de ladite deuxième tige de piston (26) et prévu agir entre ladite deuxième

tige de piston (26) et ledit corps tubulaire (2).

20. Dispositif selon la revendication 18, **caractérisé en ce que** ledit moyen de rétention résilient comprend un ressort hélicoïdal (27) disposé autour de ladite deuxième tige de piston (26) à l'intérieur dudit corps tubulaire (2), et qui est d'un côté contraint à celui-ci et de l'autre côté contraint à ladite deuxième tige de piston (26) ou audit élément à piston (3), de façon à fonctionner en traction.
21. Dispositif selon l'une quelconque des revendications 18 à 20, **caractérisé en ce que** ledit moyen de rétention résilient (27) agit comme un moyen de mise en charge résilient.
22. Dispositif selon l'une quelconque des revendications précédentes, **caractérisé en ce qu'il** comprend un élément à mémoire témoin (31) monté sur ladite première tige de piston (6) à proximité dudit élément à piston (3) et constitué d'un matériau plastiquement déformable qui se déforme en cas de choc au-delà d'un seuil de pression prédéterminé.
23. Dispositif selon l'une quelconque des revendications précédentes, **caractérisé en ce que** ladite partie inférieure (11) est agencée à ladite première extrémité (5) dudit corps tubulaire (2) et possède une bride (12) servant de support et de dispositif d'aboutement.

Fig. 1

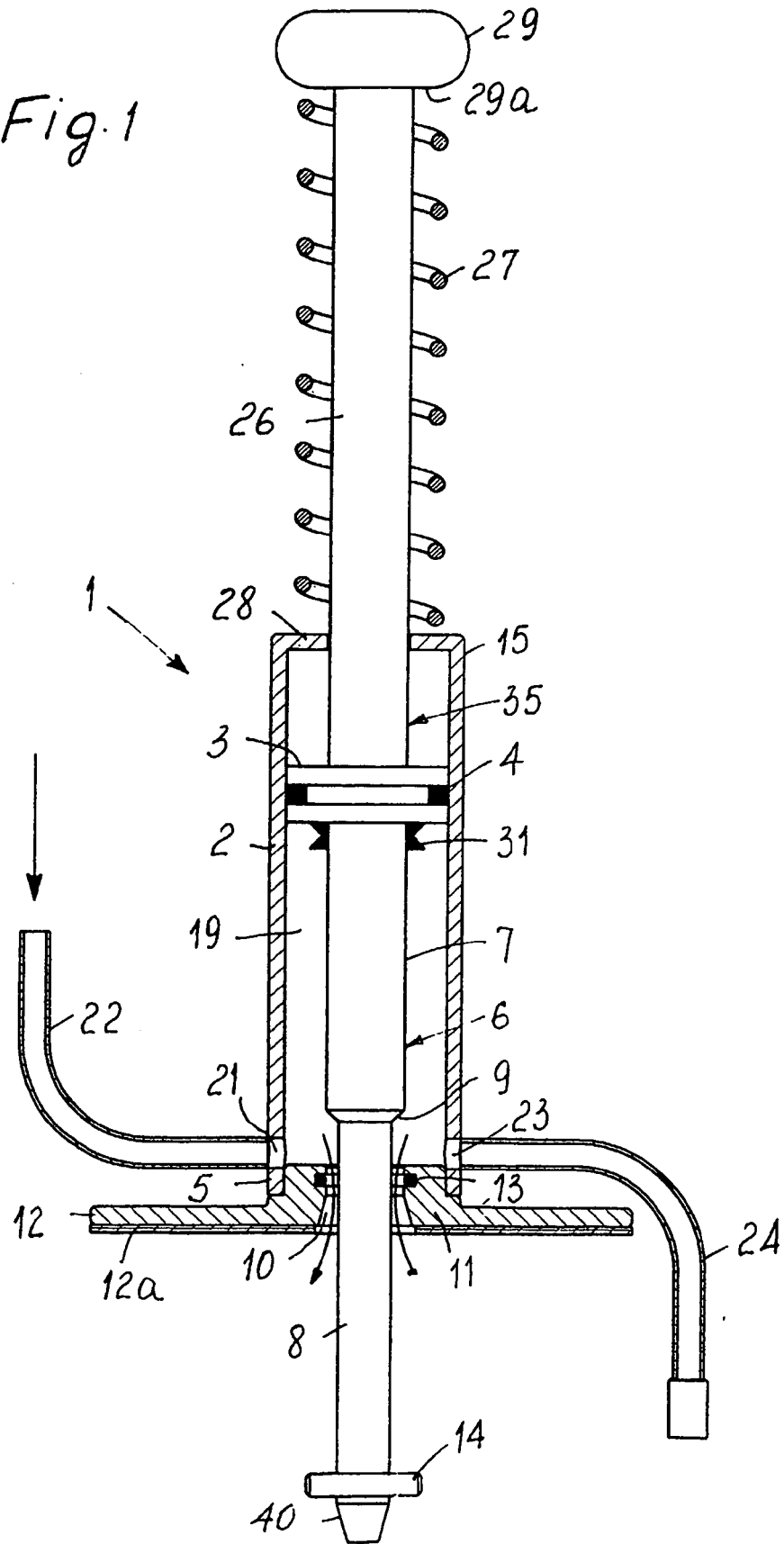
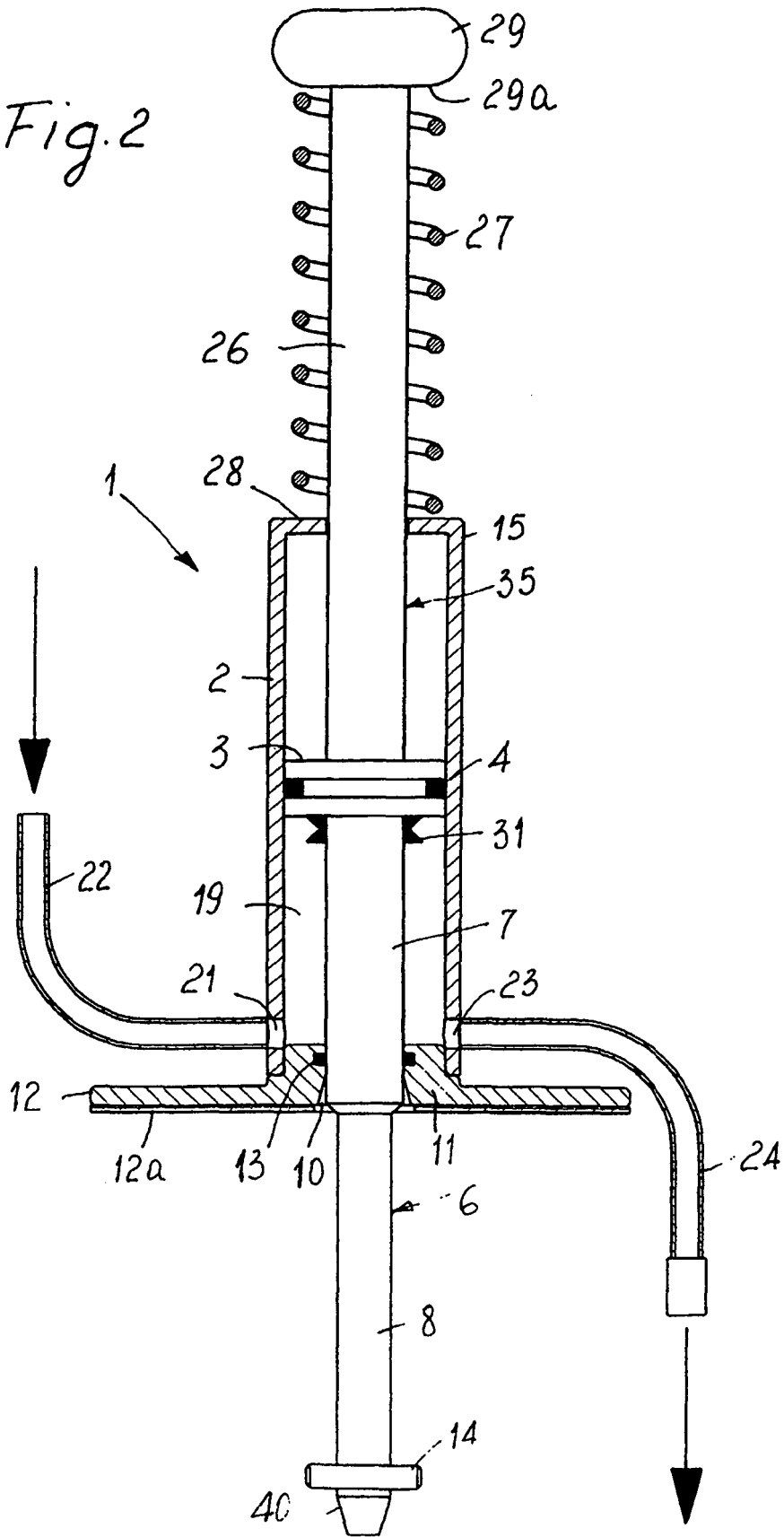

Fig. 2



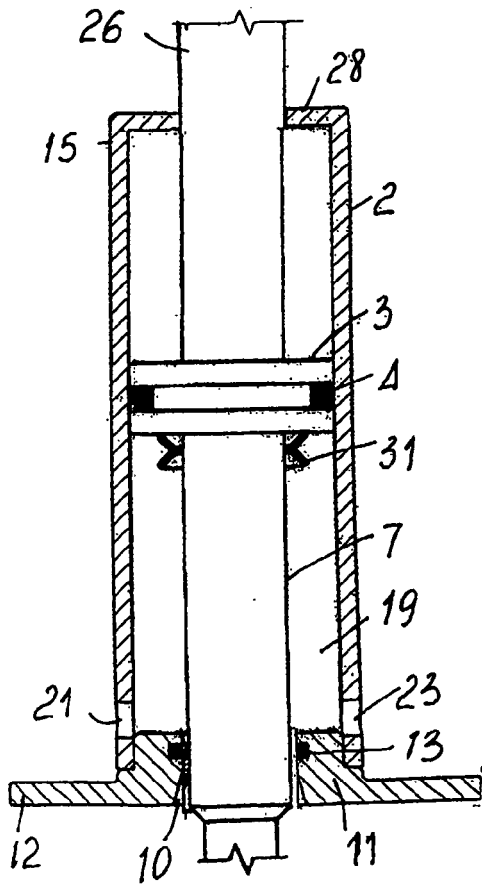

Fig. 3a

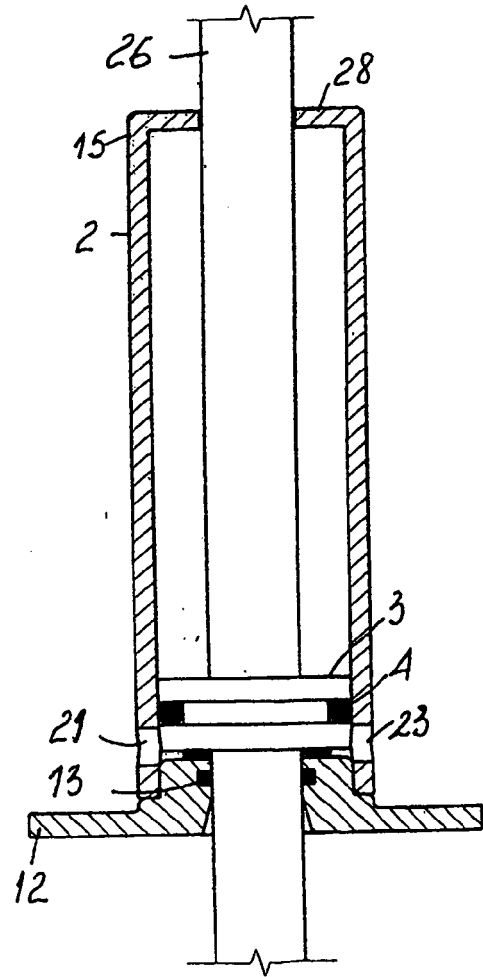
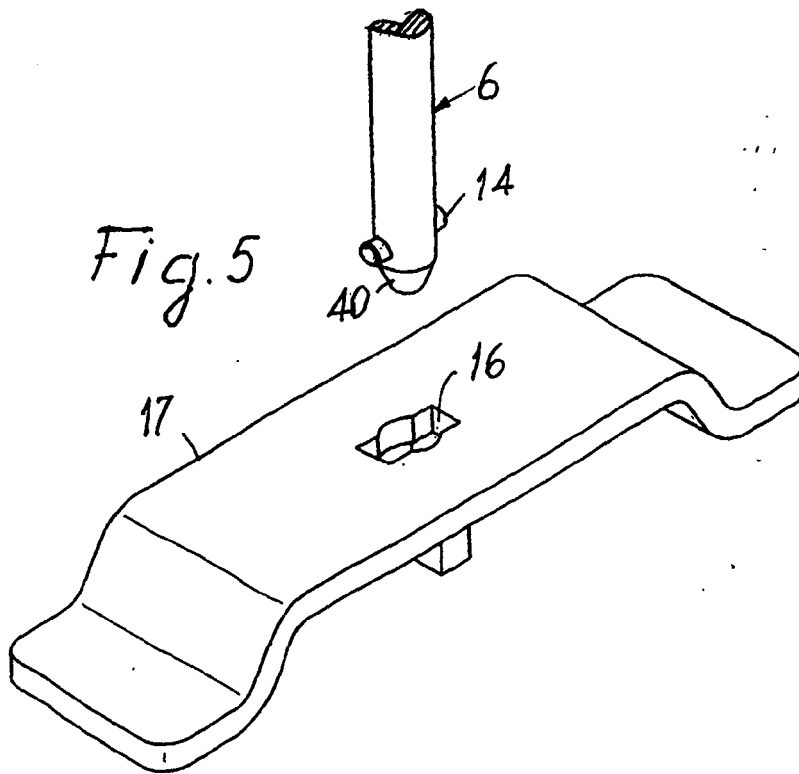
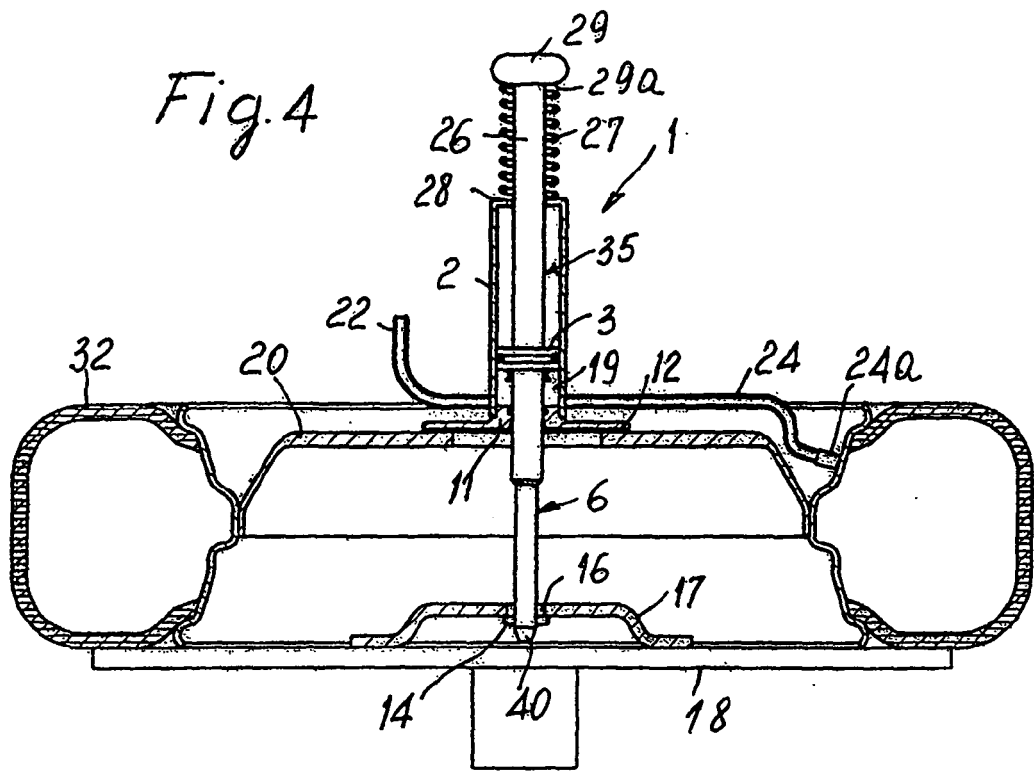
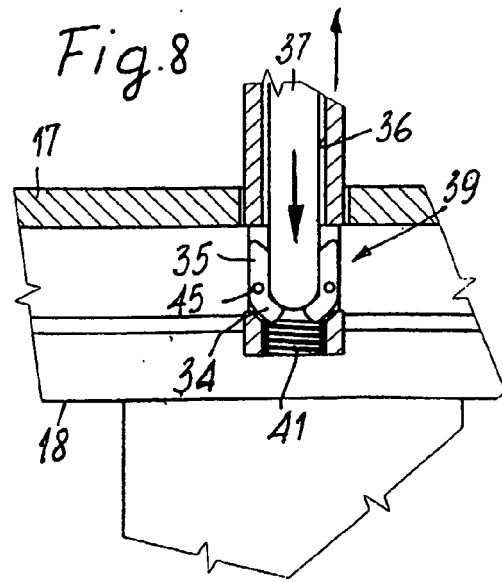
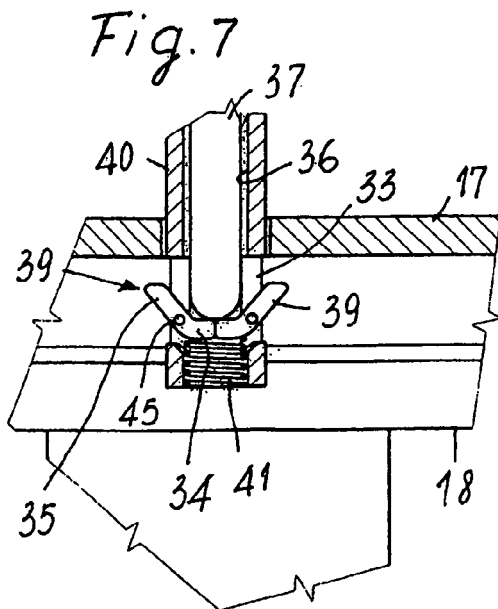
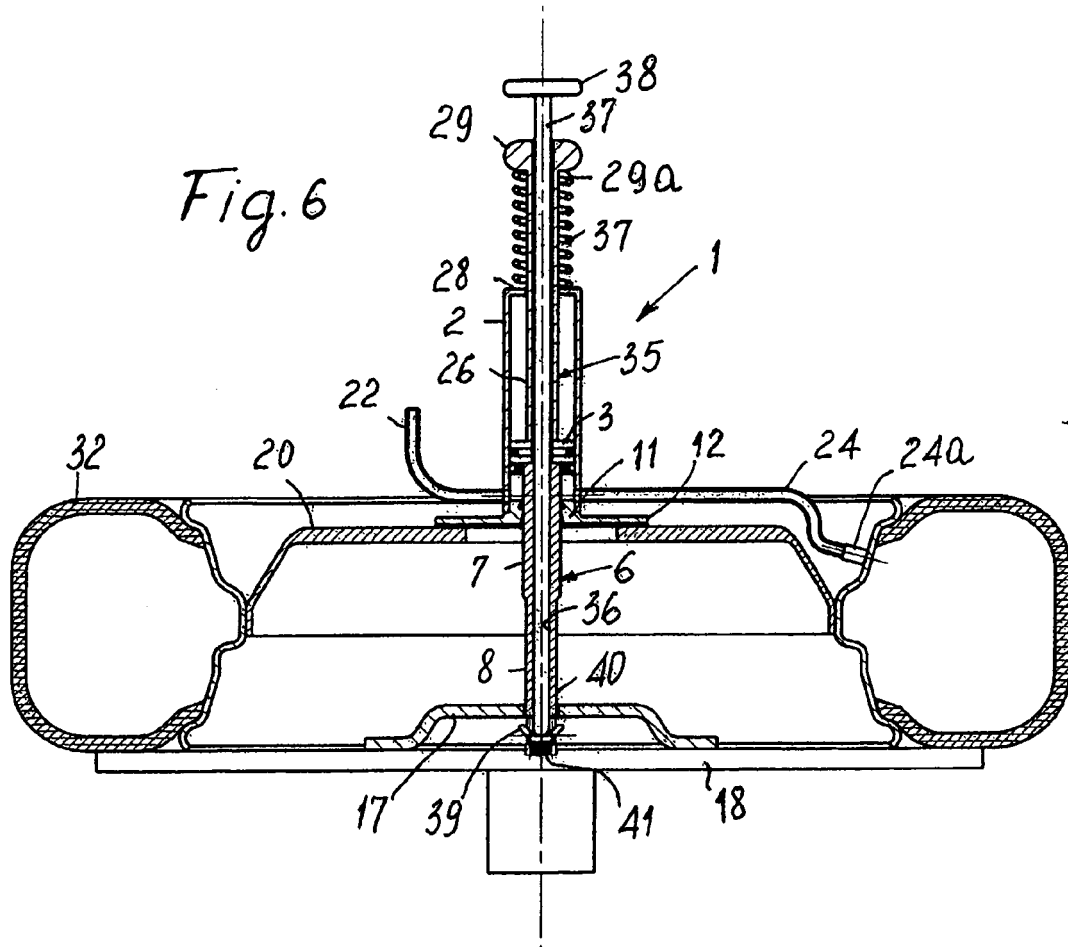
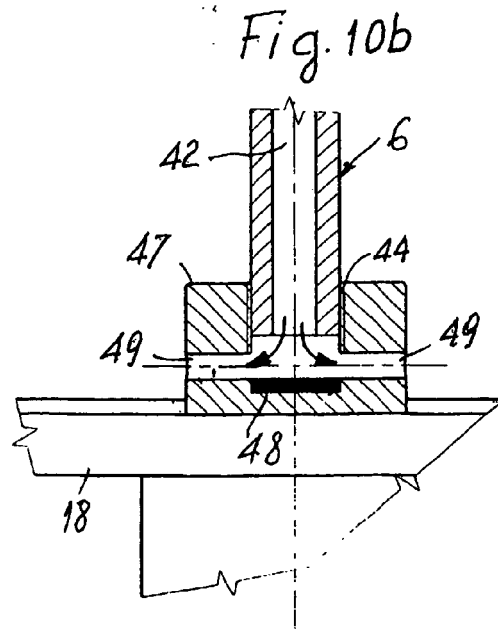
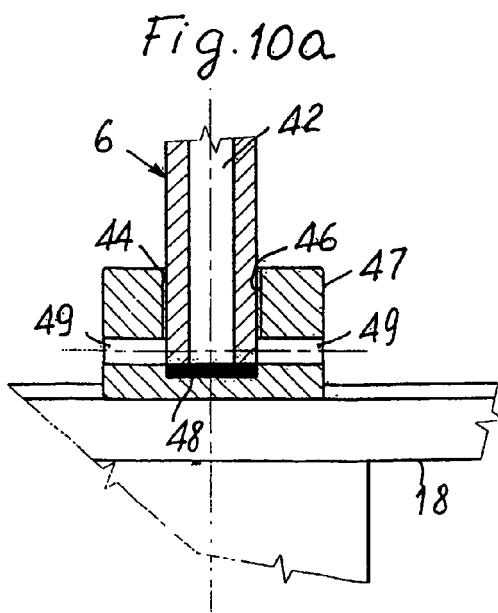
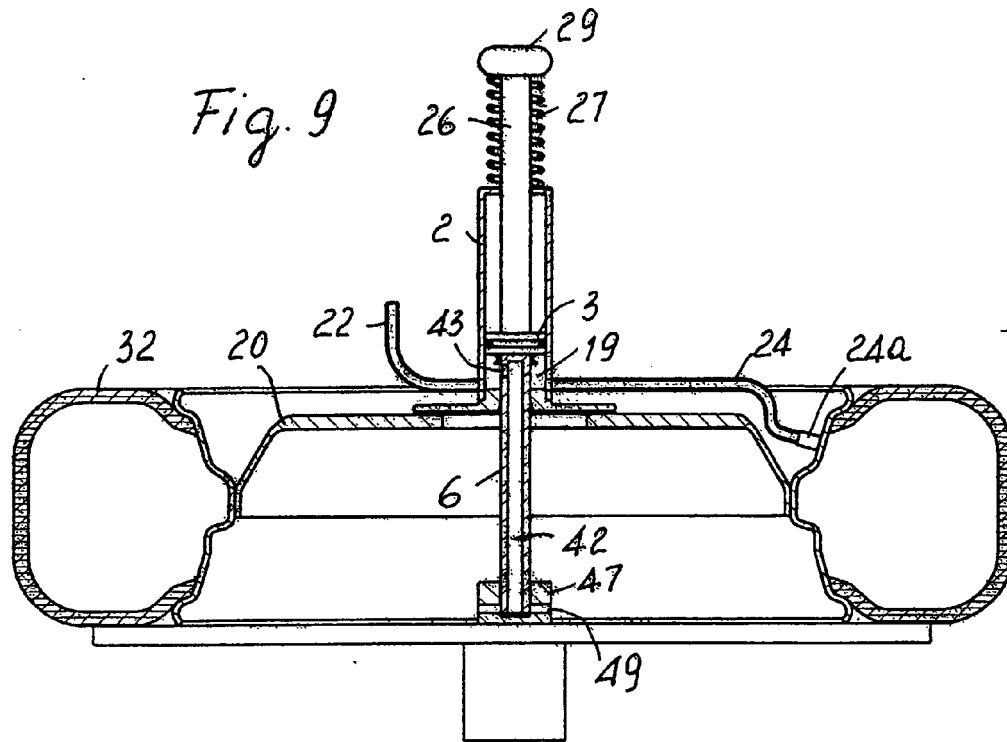

Fig. 3b.







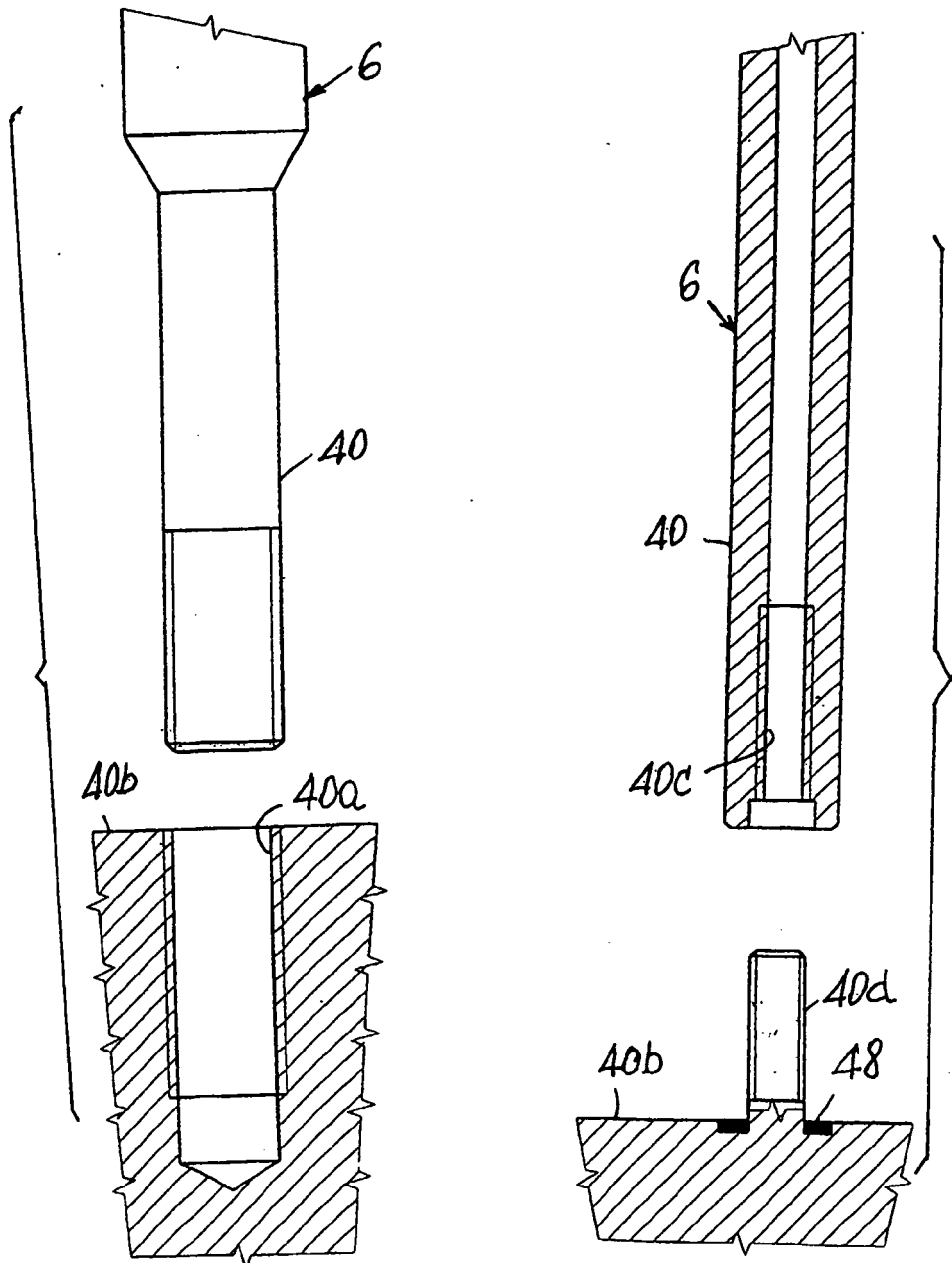

Fig. 11

Fig. 12

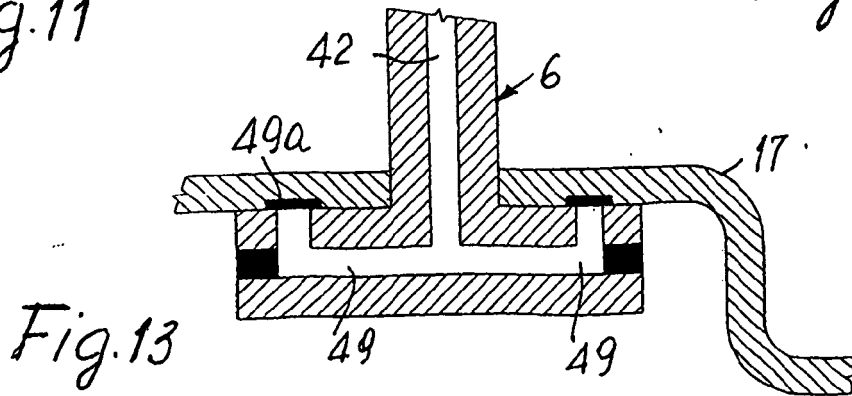

Fig. 13

**REFERENCES CITED IN THE DESCRIPTION**

*This list of references cited by the applicant is for the reader's convenience only. It does not form part of the European patent document. Even though great care has been taken in compiling the references, errors or omissions cannot be excluded and the EPO disclaims all liability in this regard.*

**Patent documents cited in the description**

- US 6173751 A [0002]