



Europäisches Patentamt
 European Patent Office
 Office européen des brevets



(11) **EP 1 310 196 A3**

(12) **EUROPEAN PATENT APPLICATION**

(88) Date of publication A3:
22.10.2003 Bulletin 2003/43

(51) Int Cl.7: **A47C 27/08**

(43) Date of publication A2:
14.05.2003 Bulletin 2003/20

(21) Application number: **02079573.8**

(22) Date of filing: **31.10.2002**

(84) Designated Contracting States:
**AT BE BG CH CY CZ DE DK EE ES FI FR GB GR
 IE IT LI LU MC NL PT SE SK TR**
 Designated Extension States:
AL LT LV MK RO SI

(72) Inventor: **Brunso, Henrik
 8680 Ry (DK)**

(74) Representative: **Plougmann & Vingtoft A/S
 Sundkrogsgade 9,
 P.O. Box 831
 2100 Copenhagen (DK)**

(30) Priority: **12.11.2001 DK 200101680**

(71) Applicant: **Akva Waterbeds ApS
 8680 Ry (DK)**

(54) **A corner piece for a water mattress, a method and a mould for manufacturing such corner piece and a water mattress with such corner piece**

(57) The invention relates to a corner piece for a water mattress. The corner piece is characterised by being designed so that any risk of fracture is limited, especially fracture due to fatigue of the corner piece during daily use. This object is obtained by shaping the corner piece

in its final shape already during molding of the corner piece, i.e. before securing the corner piece with the top side, the bottom side and the side walls of the mattress, and by providing the corner piece with only rounded edges and corners.

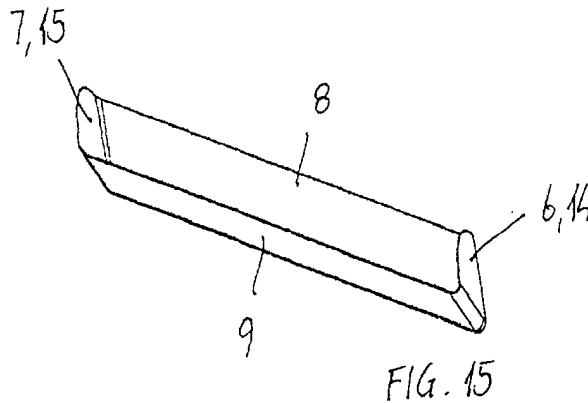

EP 1 310 196 A3



European Patent
Office

EUROPEAN SEARCH REPORT

Application Number
EP 02 07 9573

DOCUMENTS CONSIDERED TO BE RELEVANT			
Category	Citation of document with indication, where appropriate, of relevant passages	Relevant to claim	CLASSIFICATION OF THE APPLICATION (Int.Cl.7)
A	EP 0 538 539 A (BOYD DENNIS) 28 April 1993 (1993-04-28) * column 4, line 5-12; claim 1; figure 5 *	1-20,24,25	A47C27/08
D,A	US 4 930 172 A (JOHENNING JOHN B) 5 June 1990 (1990-06-05) * claim 2; figures *	1,21	
A	DE 37 23 775 A (LARSON LYNN DUANE ;LARSON RONALD LEE (US); STENTZ TERRY LEE (US)) 3 March 1988 (1988-03-03) * column 3, line 62-64; figures 1-3 *	1	
D,A	US 5 090 075 A (LARSON LYNN D) 25 February 1992 (1992-02-25) * abstract; figure 1 *		
A	US 3 999 236 A (MACAULEY CHRISTOPHER LEE) 28 December 1976 (1976-12-28) * abstract; figures *		
			TECHNICAL FIELDS SEARCHED (Int.Cl.7)
			A47C
The present search report has been drawn up for all claims			
Place of search		Date of completion of the search	Examiner
THE HAGUE		26 August 2003	Amghar, N
CATEGORY OF CITED DOCUMENTS			
X : particularly relevant if taken alone Y : particularly relevant if combined with another document of the same category A : technological background O : non-written disclosure P : intermediate document		T : theory or principle underlying the invention E : earlier patent document, but published on, or after the filing date D : document cited in the application L : document cited for other reasons & : member of the same patent family, corresponding document	

EPO FORM 1503 03.82 (P04C01)

**ANNEX TO THE EUROPEAN SEARCH REPORT
ON EUROPEAN PATENT APPLICATION NO.**

EP 02 07 9573

This annex lists the patent family members relating to the patent documents cited in the above-mentioned European search report. The members are as contained in the European Patent Office EDP file on
The European Patent Office is in no way liable for these particulars which are merely given for the purpose of information.

26-08-2003

Patent document cited in search report	Publication date	Patent family member(s)	Publication date
EP 0538539 A	28-04-1993	US 5077847 A EP 0538539 A1	07-01-1992 28-04-1993
US 4930172 A	05-06-1990	US 5373594 A US 5411621 A US 5113541 A	20-12-1994 02-05-1995 19-05-1992
DE 3723775 A	03-03-1988	CA 1333101 C DE 3723775 A1 JP 63051807 A NO 872745 A	15-11-1994 03-03-1988 04-03-1988 22-02-1988
US 5090075 A	25-02-1992	AU 8643991 A WO 9219133 A1	21-12-1992 12-11-1992
US 3999236 A	28-12-1976	NONE	