



(11) **EP 1 317 963 B1**

(12) **EUROPEAN PATENT SPECIFICATION**

(45) Date of publication and mention of the grant of the patent:  
**06.05.2009 Bulletin 2009/19**

(51) Int Cl.:  
**B05B 11/00 (2006.01)**

(21) Application number: **02023623.8**

(22) Date of filing: **18.10.2002**

(54) **Trigger-type sprayer with stopper member**

Hebelbetätigter Zerstäuber mit Stoppteil

Pulvérisateur à gâchette avec dispositif d'arrêt

(84) Designated Contracting States:  
**DE FR GB IT NL**

(30) Priority: **06.12.2001 JP 2001373167**

(43) Date of publication of application:  
**11.06.2003 Bulletin 2003/24**

(73) Proprietor: **Mitani Valve Co.**  
**Tokyo 101-0025 (JP)**

(72) Inventors:

- **Amano, Hitoshi**  
**Tokyo 101-0025 (JP)**
- **Udagawa, Takashi**  
**Tokyo 101-0025 (JP)**
- **Ueda, Hiroyuki**  
**Tokyo 101-0025 (JP)**

(74) Representative: **Schwabe - Sandmair - Marx**  
**Patentanwälte**  
**Stuntzstrasse 16**  
**81677 München (DE)**

(56) References cited:  
**EP-A- 0 803 295**                      **US-A- 4 278 187**  
**US-A- 4 441 633**

- **PATENT ABSTRACTS OF JAPAN vol. 1999, no. 08, 30 June 1999 (1999-06-30) & JP 11 076886 A (KAO CORP), 23 March 1999 (1999-03-23)**
- **PATENT ABSTRACTS OF JAPAN vol. 1998, no. 06, 30 April 1998 (1998-04-30) & JP 10 045154 A (YOSHINO KOGYOSHO CO LTD), 17 February 1998 (1998-02-17)**
- **PATENT ABSTRACTS OF JAPAN vol. 1997, no. 07, 31 July 1997 (1997-07-31) & JP 09 057161 A (YOSHINO KOGYOSHO CO LTD), 4 March 1997 (1997-03-04)**

**EP 1 317 963 B1**

Note: Within nine months of the publication of the mention of the grant of the European patent in the European Patent Bulletin, any person may give notice to the European Patent Office of opposition to that patent, in accordance with the Implementing Regulations. Notice of opposition shall not be deemed to have been filed until the opposition fee has been paid. (Art. 99(1) European Patent Convention).

## Description

### BACKGROUND OF THE INVENTION

#### Field of the Invention

**[0001]** The present invention is concerned with a sprayer for spraying a cosmetic, an antiseptic solution, a washing solution, a drug, or a coating material, which works to spray the content in a cylinder chamber into the outside at a nozzle through a piston when a trigger lever is turned to push the pushing member down. The invention further relates to a trigger-type spray unit in the sprayer which is mounted on the open portion of the container to suck the content and to spray it to the outside according to the features of the preamble of claim 1. A trigger type spray unit comprising those features is known from JP 11-076886 A.

#### Description of the Related Art

**[0002]** In a conventional sprayer with the trigger-type spray unit as taught in, for example, Japanese Patent Application (Kokai) No. 210601/2000, a lock member which is a stopper member is fitted to the nozzle when the sprayer is not in use thereby to block the trigger lever from being turned.

**[0003]** According to Japanese Patent Application (Kokai) No. 233145/2000, further, a lock member which is a stopper member is fitted to the nozzle so as to rotate. When the sprayer is not in use, the lock member is turned so that the operation portion thereof protrudes outward through a split groove thereby to prevent the trigger lever from turning.

**[0004]** However, both of the above sprayers have poor appearance. Besides, when the sprayers are to be used, the stopper member must be removed. Or, the stopper member is so constructed as can be easily removed. Therefore, the user often finds that the stopper member is missing. Besides, the sprayer cannot be easily operated by one hand involving a problem in regard to operability.

**[0005]** JP-A-11-076886 discloses a trigger-type spray unit comprising a trigger lever, which is rotatably supported for driving a reciprocating piston. A ring-type stopper is rotatably supported by a supporting shaft, which is parallel to the operation direction of the trigger. The stopper can be rotated between a work position of rotation-locking the trigger and to a non-work position, which removes the nose from the rear side of the trigger sideward so that the trigger can be rotated freely as to drive the reciprocating piston.

**[0006]** Operation of the stopper by rotating around a direction in parallel to the direction, in which the trigger is operated, is difficult. Furthermore, the nose of the stopper is exposed so that it can be broken easily.

**[0007]** It is an object of the present invention, to provide a trigger-type spray unit that can be operated by one

hand more easily, featuring improved operability.

**[0008]** The above object is solved by a trigger-type spray unit comprising the features of claim 1. Further advantageous embodiments are the subject matter of the dependent claims.

**[0009]** In the trigger-type spray unit, it is desired that the pushing member has a hitting protuberance that hits the stopper member when the stopper member is turned to the locking position, and the stopper member has an escaping recess that escapes the hitting protuberance when the stopper member is turned to the unlocking position.

**[0010]** In the trigger-type spray unit, it is further desired that the stopper member is provided with a handle.

**[0011]** In the trigger-type spray unit, it is desired that the stopper member is turned to the locking position and to the unlocking position with click feeling.

**[0012]** According to the present invention, a sprayer is provided with the trigger-type spray unit.

### BRIEF DESCRIPTION OF THE DRAWINGS

#### [0013]

Fig. 1 is a perspective view illustrating the appearance of an trigger-type spray unit for a sprayer according to the present invention;

Fig. 2 is a vertical sectional view;

Fig. 3 is a vertical sectional view of a first piston used in the trigger-type spray unit;

Fig. 4 is a vertical sectional view of an elastic valve used in the trigger-type spray unit;

Fig. 5 is a perspective view of a second piston used in the trigger-type spray unit;

Fig. 6(A) is a bottom view of the second piston;

Fig. 6(B) is a bottom view of the second piston according to another embodiment;

Fig. 6(C) is a bottom view of the second piston according to a further embodiment;

Fig. 7 is a perspective view of a stopper member used in the trigger-type spray unit;

Fig. 8(A) is a plan view of the stopper member;

Fig. 8(B) is a vertical sectional view thereof;

Fig. 9 is a perspective view of a pushing member used in the trigger-type spray unit; and

Fig. 10 is a vertical sectional view illustrating a state where the trigger-type spray unit is being used.

### DESCRIPTION OF THE PREFERRED EMBODIMENTS

**[0014]** An embodiment of the present invention will now be described with reference to the drawings.

**[0015]** Fig. 1 is a perspective view illustrating the appearance of an trigger-type spray unit for a sprayer according to the present invention, and Fig. 2 is a vertical sectional view thereof.

**[0016]** In these drawings, reference numeral 10 denotes a container. The container 10 is made of a plastic

material in the shape of a bottle, is externally threaded along the outer periphery of the open portion 10a, and contains a spraying solution therein as a content.

**[0017]** A trigger-type spray unit P is mounted on the open portion 10a of the container 10.

**[0018]** The trigger-type spray unit P is provided with a threaded cap 12. The cap 12 is internally threaded in the inner periphery thereof, and has a center hole 12b formed at the center in a top portion 12a thereof. The top portion 12a is placed on a flange 13a of a cylinder 13, and is screwed onto the open portion 10a of the container via a packing which, therefore, is compressed between the top portion 12a and the open portion 10a.

**[0019]** The cylinder 13 includes three stepped portions 13b, 13c and 13d of which the diameters gradually decreasing downward in the drawing.

**[0020]** The cylinder 13 has, at an upper portion thereof, the above-mentioned flange 13a surrounding the first stepped portion 13b, has an air suction hole 13e perforated just below the flange 13a so as to penetrate through in the radial direction, and has an upper end portion 13f protruding upward through the center hole 12b in the threaded cap 12.

**[0021]** At the lower portion of the cylinder 13, a valve seat 13g is formed at the lower inner portion of the third stepped portion 13d, the valve seat 13g having a diameter that gradually decreases downward. Under the valve seat 13g, a tubular pipe-mounting port 13h is provided continuing hereto. An upper end of a suction pipe 14 is forcibly introduced into the pipe mounting-port 13h.

**[0022]** A ball-like check valve 16 is introduced into the cylinder 13, placed on the valve seat 13g and, then, a coil spring 17 is inserted therein and is placed on the third stepped portion 13d. Then, a first piston 18 is inserted in the cylinder 13 with its flange portion 18a being placed on the coil spring 17.

**[0023]** As solely shown in Fig. 3, the first piston 18 has an upwardly faced annular groove 18b formed in the upper surface of the flange portion 18a, and has a plurality of longitudinal grooves 18c formed in the outer periphery thereof right above the flange portion 18a.

**[0024]** Referring to Fig. 2, an elastic valve 20 is placed on the flange portion 18a of the first piston 18 to thereby define a cylinder chamber S in the cylinder 13. As solely shown in Fig. 4, the elastic valve 20 has an annular shape with its cross section being of an H-shape. An outer peripheral lower end 20a of the elastic valve 20 is pushed onto the inner peripheral surface of the cylinder 13, an inner peripheral lower end 20b which is slightly shorter than the outer peripheral lower end 20a is inserted in the annular groove 18b, and an inner cylindrical portion 20c protruding upward is permitted to stay along the outer periphery of the first piston 18 maintaining a small gap a.

**[0025]** On the first piston 18 is placed a second piston 22 to thereby constitute a piston 21 together with the first piston 18. As also shown solely in Fig. 5, the second piston 22 includes a slender small-diameter cylindrical portion 22a, an intermediate-diameter cylindrical portion

22b, and a large diameter cylindrical portion 22c. The intermediate-diameter cylindrical portion 22b has a plurality of longitudinal grooves 22e formed in the inner periphery thereof, and in which is inserted the upper part of the first piston 18. The large-diameter cylindrical portion 22c has a shoulder portion 22f that is inclined, and into the inner peripheral surface thereof is pushed the upper end of the inner cylindrical portion 20c of the elastic valve 20.

**[0026]** In the embodiment as also shown in Fig. 6(A), four leg portions 22d extend downward from the lower end of the large diameter cylindrical portion 22c, and come into contact with the inclined outer surface 20e at the base portion of the inner cylindrical portion 20c. As shown in Fig. 6(B), the leg portions 22d may have an increased width b or, though not shown, may have a decreased width. Further, the number of the legs may be decreased down to two as shown in Fig. 6(C), or may be increased though not shown.

**[0027]** A stop cap 23 is attached around the large-diameter cylindrical portion 22c of the second piston 22. The stop cap 23 includes a cap portion 23a, a cylindrical portion 23b protruding upward from the top portion thereof in concentric, and a support portion 23c extending upward and being inclined from the shoulder portion of the cap portion 23a.

**[0028]** The cap portion 23a is fitted so as to cover the upper end portion 13f of the cylinder 13, holds the top portion 12a to prevent the threaded cap 12 from escaping, and compresses the packing 24 between itself and the first stepped portion 13b. The packing 24 is in contact with the outer peripheral upper end 20d of the elastic valve 20.

**[0029]** The cylindrical portion 23b has an annular groove 23d formed in the inner periphery at an upper portion thereof, and has a click-engaging portion 23e protruding upward from the side of the outer peripheral support portion 23c. A stopper member 25 is fitted into the annular groove 23d from the upper side so as to rotate therein. As illustrated in Figs. 7, 8(A) and 8(B), the stopper member 25 includes a skirt portion 25a to be fitted to the cylindrical portion 25b, a cylindrical portion 25b formed on the skirt portion 25a in concentric, and a handle 25c extending in the radial direction from the outer periphery of the cylindrical portion 25b.

**[0030]** The cylindrical portion 25b has a stepped portion 25d formed at an upper edge in the inner peripheral surface thereof, has four escaping recesses 25e extending down from the stepped portion 25d like longitudinal grooves maintaining a distance of 90 degrees, and has tapered portions 25f formed at the inlet. Three click protuberances 25g are formed on the outer peripheral surface at the lower edge thereof maintaining a distance of 90 degrees and 180 degrees from the handle 25c. One of the click protuberances 25g is resiliently click-fitted to the click-engaging portion 23e, and the stopper member 25 is turned and positioned to either the locking position or the unlocking position.

**[0031]** The base end of a trigger lever 26 is attached to an end of the support portion 23c of the stop cap 23 so as to rotate. The trigger lever 26 is folded at right angles, and the folded portion includes a peripheral surface portion 26b with a notch 26a and side surface portions 26c that are opposing to each other on both sides. Downwardly directed engaging recesses 26d are formed in the inner surfaces of the side surface portions 26c.

**[0032]** The engaging recesses 26d engage with engaging protuberances 27a of a pushing member 27. The pushing member 27 is folded at about 90 degrees like an elbow, and is constituted by a vertical single-pipe portion 27b on the base side and a horizontal double-pipe portion 27c on the front end side. On both sides at the upper part of the single-pipe portion 27b, there are formed the above-mentioned circular engaging protuberances 27a and a slender hitting protuberance 27d extending downward therefrom.

**[0033]** The double-pipe portion 27c comprises an outer cylinder and an inner cylinder slightly protruding beyond the outer cylinder. Referring to Fig. 2, a cylindrical base end 28a of a nozzle holder 28 is fitted into between the outer cylinder and the inner cylinder. A nozzle member 30 is attached to an end of the nozzle holder 28, and a nozzle 30a formed in the nozzle member 30 is communicated with a blow-out passage 27e in the inner cylinder of the double-pipe portion 27c.

**[0034]** The single-pipe portion 27b of the pushing member 27 is inserted in the cylindrical portion 25b of the stopper member 25 and in the cylindrical portion 23b of the top cap 23 so as to cover the small-diameter portion 22a and the intermediate-diameter portion 22b of the second piston 22, and the nozzle holder 28 protrudes outward through the notch 26a of the trigger lever 26. The blow-out passage 27e of the pushing member 27 is communicated with the flow passage 22g in the small-diameter cylinder 22a of the second piston 22, and the engaging recesses 26d are placed on the engaging protuberances 27a.

**[0035]** When not in use, the handle 25c of the stopper member 25 is directed toward a finger-touch portion 26e of the trigger lever 26 as shown in Figs. 1 and 2, and the click protuberance 25g of the opposite side is click-engaged with the click-engaging portion 23e to maintain the stopper member 25 at the locking position. Therefore, even when the user attempts to turn the trigger lever 26 by touching the finger-touch portion 26e by his fingers, the hitting protuberances 27d of the pushing member 27 hit the stepped portion 25d of the stopper member 25, whereby the pushing member 27 is blocked from being pushed down, the trigger lever 26 is restricted from being turned, and the piston 21 is prevented from being pushed.

**[0036]** To use the sprayer, the user holds the container 10, operates the handle 25c with his finger, turns the stopper member 25 around the direction in which the piston 21 reciprocates to bring any one of the click protuberances 25g separated away from the handle 25c by 90 degrees into click-engagement with the click-engag-

ing portion 23e to maintain the stopper member 25 at the unlocking position.

**[0037]** Then, the user touches the finger-touching portion 26e with his finger and turns the trigger lever 26 counterclockwise in Fig. 10, whereby the hitting protuberances 27d of the pushing member 27 enter into the escaping recesses 25e of the stopper member 25 enabling the pushing member 27 to be pushed down, causing the piston 21 as well as the elastic valve 20 to be pushed in overcoming the coil spring 17, and whereby the pressure in the cylinder chamber S is elevated to push up the elastic valve 20. Namely, the trigger lever 26 is turned to push a pushing member down, then the pushing member 27 is pushed by the trigger lever 26 to push the piston 21.

**[0038]** As the pressure in the cylinder chamber S exceeds a predetermined value, the leg portions 22d of the second piston 22 are deformed to be opened outward, whereby a gap is formed between the elastic valve 20 and the first piston 18, and the inner peripheral lower end 20b of the elastic valve 20 is drawn out from the annular groove 18b in the flange portion 18a of the first piston 18. The content in the cylinder chamber S is introduced into the second piston 22 through the longitudinal grooves 18c, is caused to flow into the blow-out passage 27e of the pushing member 27 through a passage 22g from the vertical grooves 22e of the second piston 22, and is sprayed to the outside at the nozzle 30a through the piston 21 and the pushing member 27. Then, the flange portion 18a of the first piston 18 comes into contact with the second stepped portion 13c of the cylinder 13 to come into a halt.

**[0039]** Then, as the content in the cylinder chamber S is sprayed and the pressure in the cylinder chamber S drops, the leg portions 22d that had been deformed return back to normal, whereby the elastic valve 20 is pushed down, and the inner peripheral lower end 20b of the elastic valve 20 is introduced into the annular groove 18b in the flange portion 18a. Then, as the user separates his fingers off the finger-touch portion 26e, the piston 21 and the pushing member 27 are raised due to the urging force of the coil spring 17, and the trigger lever 26 is turned clockwise to return to the initial state.

**[0040]** Then, the pressure in the cylinder chamber S becomes negative, whereby the ball valve 16 is opened and the content in the container 10 is sucked into the cylinder chamber S through the suction pipe 14. Then, as the pressure in the cylinder chamber S assumes the atmospheric pressure, the ball valve 16 falls again on the valve seat 13g to close the suction port.

**[0041]** If the trigger lever 26 is turned, therefore, the content can be sprayed again through the nozzle 30a. Upon repeating this operation, the content can be sprayed any number of times until the content in the container 10 is depleted.

**[0042]** Incidentally, in the present invention, to spray means both discharging the content at the nozzle as small drops and discharging the content at the nozzle as a linear series.

**[0043]** To discontinue the use, the handle 25c is operated by a finger to turn the stopper member 25 to the locking position shown in Fig. 2 around the direction in which the piston 21 reciprocates. And the pushing member 27 is blocked from being pushed down by the stopper member 25 in order to limit the turn of the trigger lever 26.

**[0044]** In the illustrated embodiment, when it is desired to elevate the pressure that is accumulated so that the content in the cylinder chamber S is blown out at one time with a relatively strong pressure, there may be used the second piston 22 having leg portions 22d of a large width b as shown in Fig. 6(B) or having an increased number of leg portions 22d, or there may be used the elastic valve 20 having an outer surface 20e that is inclined at a large angle at the base portion of the inner cylindrical portion 20c, such that the leg portions 22d are deformed little and that the rise of the elastic valve 20 is suppressed with an increased force.

**[0045]** Conversely, when it is desired to decrease the pressure that is accumulated so that the content in the cylinder chamber is blown out with a relatively weak pressure, there may be used the second piston 22 having leg portions 22d of a small width b or having a decreased number of leg portions 22d as shown in Fig. 6(C), or there may be used the elastic valve 20 having an outer surface 20e that is inclined at a small angle at the base portion of the inner cylindrical portion 20c, such that the leg portions 22d are easily deformed and that the rise of the elastic valve 20 is suppressed with a weak force.

**[0046]** As described above, the present invention, corresponding to claims 1 to 4, is concerned with a trigger-type spray unit for a trigger-type spray unit, wherein a stopper member is provided to turn between a locking position and an unlocking in the direction in which the piston reciprocates to block the pushing member from being pushed down when it has been turned to the locking position. Therefore, the stopper member is concealed by a relatively large trigger lever to improve the appearance.

**[0047]** The stopper member is mounted under the trigger lever at all times so will not to be removed, and is free from being lost. Besides, the stopper member can be easily operated by one hand featuring improved operability.

**[0048]** According to the present invention corresponding to claim 2, further, the pushing member has a hitting protuberance that hits the stopper member when the stopper member is turned to the locking position, and the stopper member has an escaping recess that escapes the hitting protuberance when the stopper member is turned to the unlocking position. Therefore, the pushing member is blocked from being pushed down and the blocked state is reset relying upon a simple structure.

**[0049]** According to the present invention corresponding to claim 3, the stopper member is provided with a handle which is to be operated by a finger when the stopper member is to be turned. Therefore, the stopper member can be easily turned.

**[0050]** According to the present invention correspond-

ing to claim 4, the stopper member is turned to the locking position and to the unlocking position with click feeling, enabling the stopper member to be reliably positioned without error.

**[0051]** According to the present invention corresponding to claim 5, further, there is provided a sprayer equipped with the above trigger-type spray unit of the invention offering the above-mentioned effect.

## Claims

1. A trigger-type spray unit for a sprayer, said trigger-type spray unit (P) being configured to be mounted on the open portion (10a) of a container (10) and being provided with:

a trigger lever (26),  
a pushing member (27), and  
a piston (21), wherein  
said trigger lever (26) is rotatably supported for pushing said pushing member (27) down during use so as to push down said piston (21), and wherein said piston (21) reciprocates in a predetermined direction for spraying the content in a cylinder chamber (S) to the outside of the sprayer at a nozzle (30a) through the piston (21) and the pushing member (27) on the piston (21) being pushed down, and for sucking a content in the container (10) into the cylinder chamber (S), said trigger-type spray unit (P) further comprising:

a stopper member (25) that is provided around the piston (21) and is turnable between a locking position and an unlocking position around the direction in which said piston (21) reciprocates **characterised in that** said stopper member (25) abuts and blocks the pushing member (27) from being pushed down when said stopper member (25) is turned to the locking position.

2. A trigger-type spray unit according to claim 1, wherein the pushing member (27) has a hitting protuberance (27d) that hits the stopper member (25) when the stopper member (25) is turned to the locking position, and wherein the stopper member (25) has an escaping recess (25e) that escapes the hitting protuberance (27d) when the stopper member (25) is turned to the unlocking position.

3. A trigger-type spray unit according to claim 1 or 2, wherein the stopper member (25) is provided with a handle (25c) to be operated by a finger when the stopper member (25) is to be turned around the direction in which said piston (21) reciprocates.

4. A trigger-type spray unit according to any one of claims 1 to 3, wherein the stopper member (25) is turned to the locking position and to the unlocking position with click feeling around the direction in which said piston (21) reciprocates.
5. A sprayer equipped with a trigger-type spray unit of any one of claims 1 to 4.

#### Patentansprüche

1. Abzug-Sprüheinheit für eine Sprühvorrichtung, wobei die Abzug-Sprüheinheit (P) konfiguriert ist, um am offenen Abschnitt (10a) eines Behälters (10) angebracht zu werden, und versehen ist mit:

einem Abzughebel (26),  
 einem Schubelement (27) und  
 einem Kolben (21), wobei  
 der Abzughebel (26) drehbar unterstützt ist, um das Schubelement (27) während des Gebrauchs nach unten zu schieben, um den Kolben (21) nach unten zu schieben, und wobei sich der Kolben (21) in einer vorgegebenen Richtung hin und her bewegt, um den Inhalt in einer Zylinderkammer (S) bei einer Düse (30a) in die äußere Umgebung der Sprühvorrichtung zu sprühen, indem der Kolben (21) und das Schubelement (27) an dem Kolben (21) nach unten geschoben werden, und um einen Inhalt in dem Behälter (10) in die Zylinderkammer (S) zu saugen, wobei die Abzug-Sprüheinheit (P) ferner umfasst:

ein Anschlagelement (25), das um den Kolben (21) vorgesehen ist und um die Richtung, in der sich der Kolben (21) hin und her bewegt, zwischen einer Verriegelungsstellung und einer Entriegelungsstellung drehbar ist, **dadurch gekennzeichnet, dass** das Anschlagelement (25) an dem Schubelement (27) anschlägt und es in Bezug auf einen Abwärtsschub blockiert, wenn das Anschlagelement (25) in die Verriegelungsstellung gedreht ist.

2. Abzug-Sprüheinheit nach Anspruch 1, wobei das Schubelement (27) einen Auftreffvorsprung (27d) besitzt, der auf das Anschlagelement (25) trifft, wenn das Anschlagelement (25) in die Verriegelungsstellung gedreht ist, und wobei das Anschlagelement (25) eine Entweichaussparung (25e) besitzt, die den Auftreffvorsprung (27d) entweichen lässt, wenn das Anschlagelement (25) in die Entriegelungsstellung gedreht ist.
3. Abzug-Sprüheinheit nach Anspruch 1 oder 2, wobei

das Anschlagelement (25) mit einem Griff (25c) versehen ist, der durch einen Finger betätigt wird, wenn das Anschlagelement (25) um die Richtung, in der sich der Kolben (21) hin und her bewegt, gedreht werden soll.

4. Abzug-Sprüheinheit nach einem der Ansprüche 1 bis 3, wobei das Anschlagelement (25) mit einem Einrastempfinden um die Richtung, in der sich der Kolben (21) hin und her bewegt, in die Verriegelungsstellung und in die Entriegelungsstellung gedreht wird.

5. Sprühvorrichtung, die mit einer Abzug-Sprüheinheit nach einem der Ansprüche 1 bis 4, ausgerüstet ist.

#### Revendications

1. Unité de pulvérisation de type à déclencheur pour un pulvérisateur, ladite unité de pulvérisation de type à déclencheur (P) étant configurée pour être montée sur la partie ouverte (10a) d'une bombe (10) et étant munie de :

une gâchette (26),  
 un élément de poussée (27), et  
 un piston (21), dans laquelle  
 ladite gâchette (26) est supportée avec une possibilité de rotation pour pousser ledit élément de poussée (27) vers le bas pendant l'utilisation de façon à pousser vers le bas ledit piston (21), et dans laquelle ledit piston (21) est animé d'un mouvement de va-et-vient dans une direction prédéterminée afin de pulvériser le contenu se trouvant dans un compartiment à cylindre (S) vers l'extérieur du pulvérisateur au niveau d'une buse (30a) au travers du piston (21) et où l'élément de poussée (27) sur le piston (21) est poussé vers le bas, ainsi que pour aspirer un contenu se trouvant dans la bombe (10) dans le compartiment du cylindre (S), ladite unité de pulvérisation de type à déclencheur (P) comprenant en outre :

un dispositif d'arrêt (25) qui est ménagé autour du piston (21) et qui peut tourner entre une position de verrouillage et une position de déverrouillage autour de la direction dans laquelle ledit piston (21) est animé du mouvement de va-et-vient, **caractérisé en ce que** ledit dispositif d'arrêt (25) vient en butée contre l'élément de poussée (27) et bloque celui-ci à partir du moment où il est poussé vers le bas lorsque ledit dispositif d'arrêt (25) est tourné vers la position de verrouillage.

2. Unité de pulvérisation de type à déclencheur selon la revendication 1, dans laquelle l'élément de poussée (27) comporte une protubérance venant en contact (27d) qui heurte le dispositif d'arrêt (25) lorsque le dispositif d'arrêt (25) est tourné vers la position de verrouillage, et dans laquelle le dispositif d'arrêt (25) possède un évidement de dégagement (25e) qui se dégage de la protubérance venant en contact (27d) lorsque le dispositif d'arrêt (25) est tourné vers la position de déverrouillage. 5  
10
3. Unité de pulvérisation de type à déclencheur selon la revendication 1 ou 2, dans laquelle le dispositif d'arrêt (25) est muni d'une poignée (25c) devant être mise en oeuvre par un doigt lorsque le dispositif d'arrêt (25) doit être tourné autour de la direction dans laquelle ledit piston (21) est animé du mouvement de va-et-vient. 15
4. Unité de pulvérisation de type à déclencheur selon l'une quelconque des revendications 1 à 3, dans laquelle le dispositif d'arrêt (25) est tourné vers la position de verrouillage et vers la position de déverrouillage avec une sensation de dé clic autour de la direction dans laquelle ledit piston (21) est animé d'un mouvement de va-et-vient. 20  
25
5. Pulvérisateur muni d'une unité de pulvérisation de type à déclencheur selon l'une quelconque des revendications 1 à 4. 30

35

40

45

50

55

FIG.1

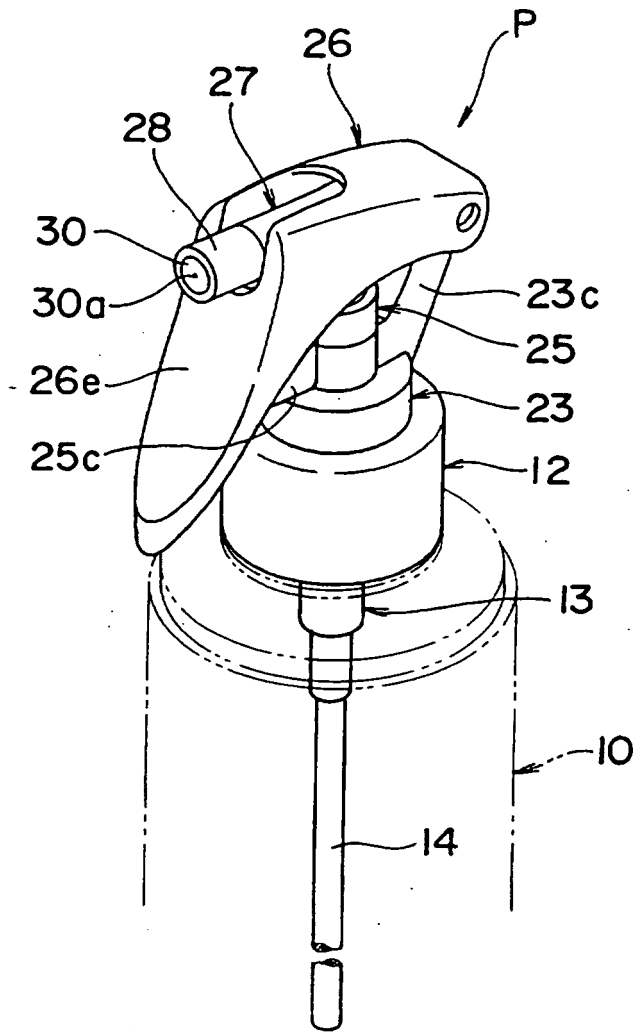

FIG.2

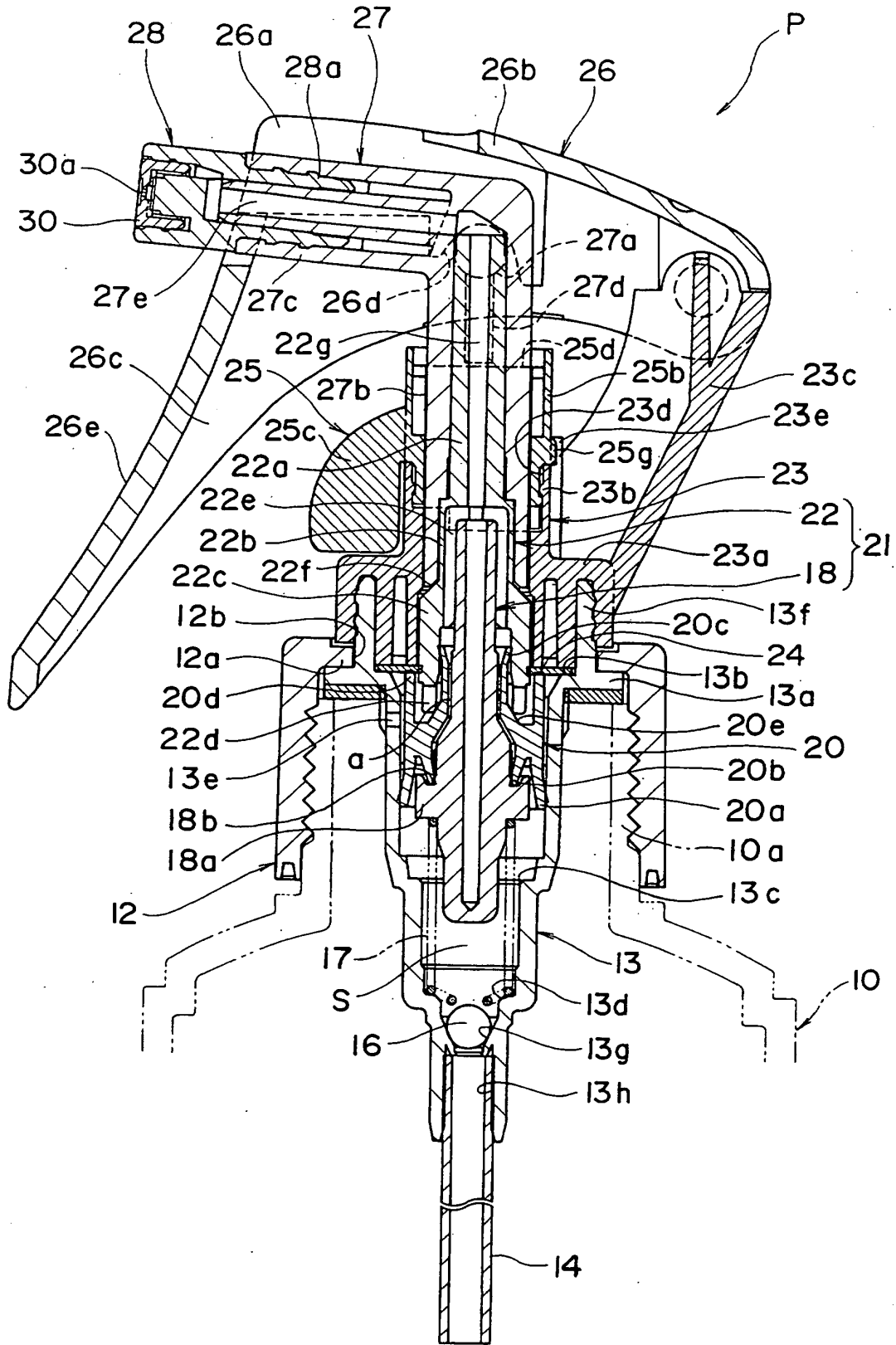

FIG.3

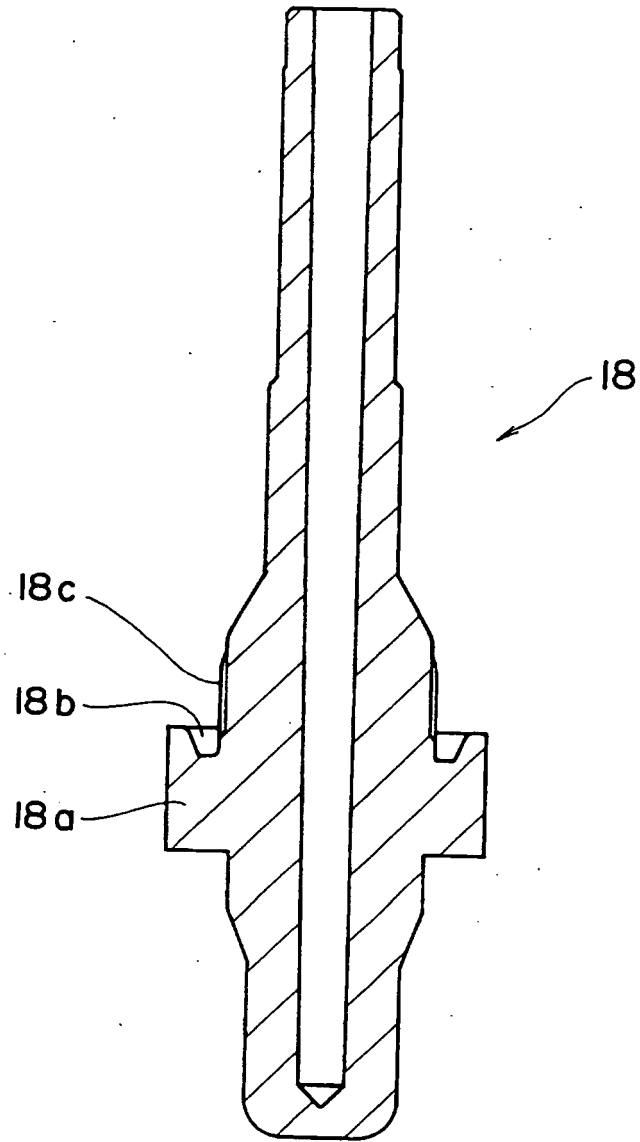

FIG.4

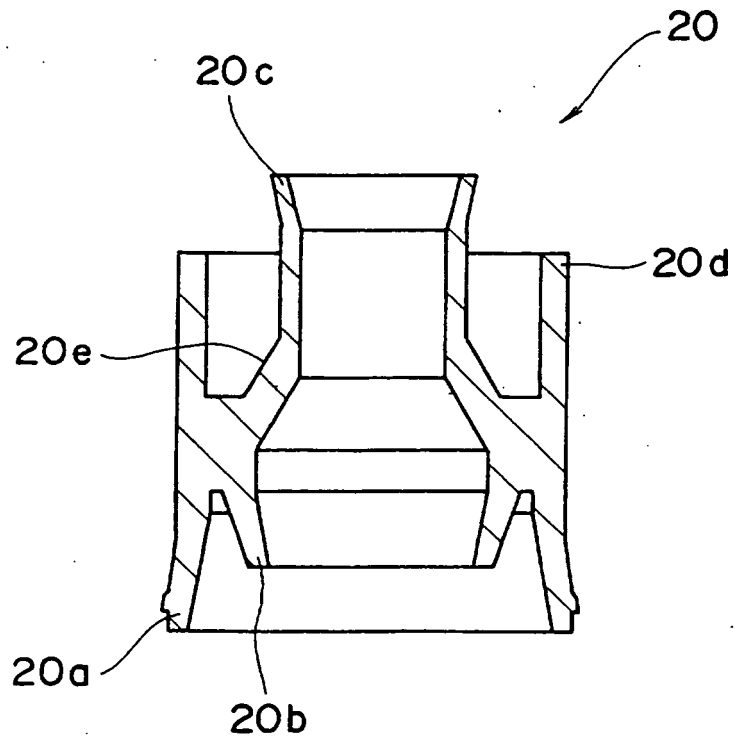

FIG.5

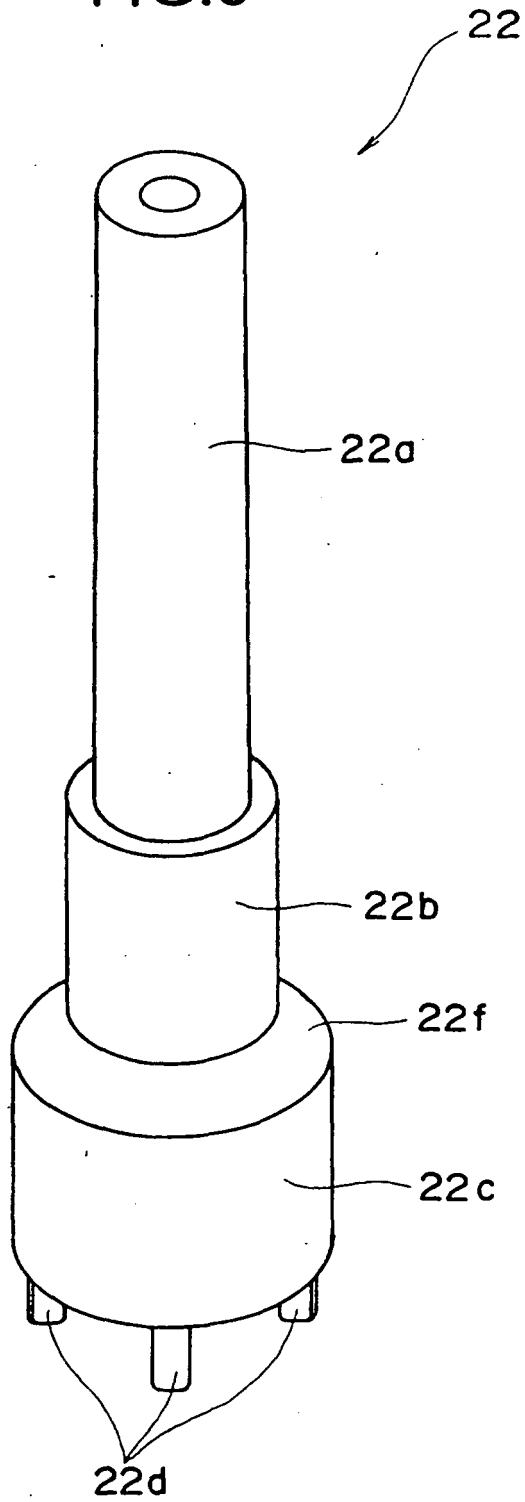

FIG.6A

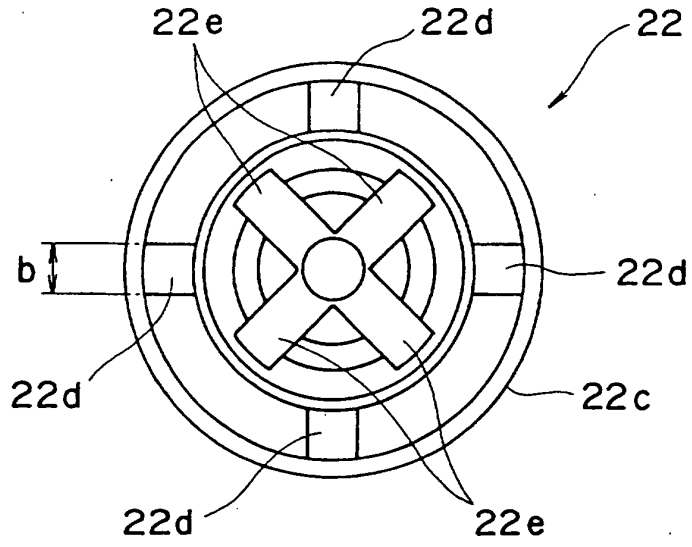

FIG.6B

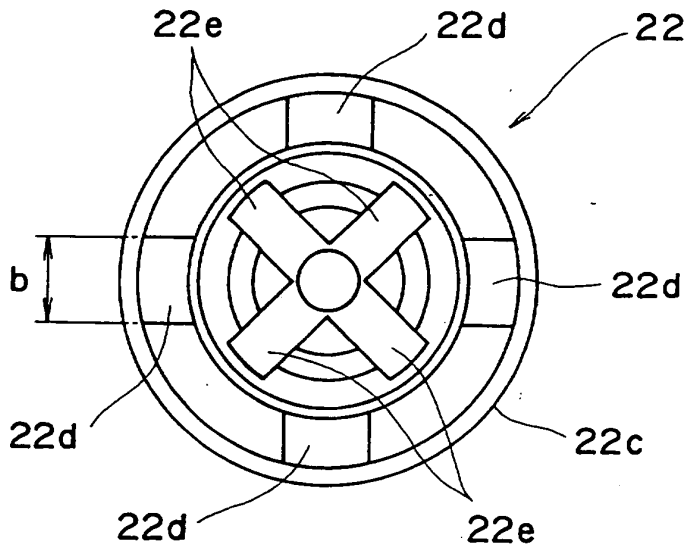

FIG.6C

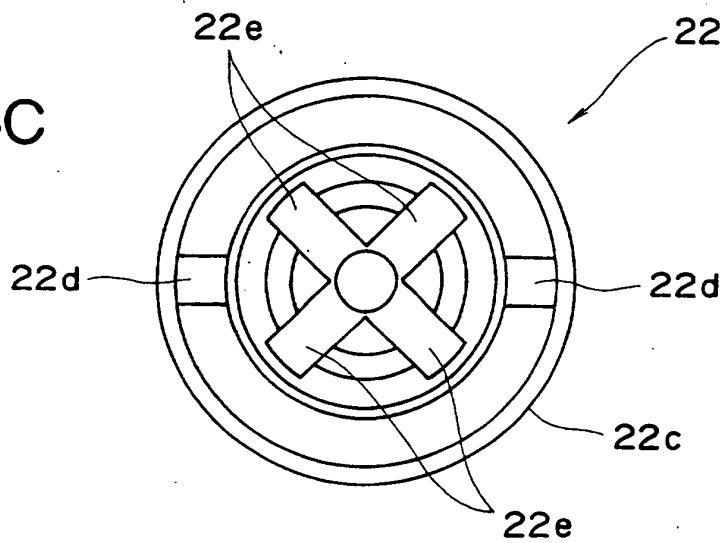

FIG.7

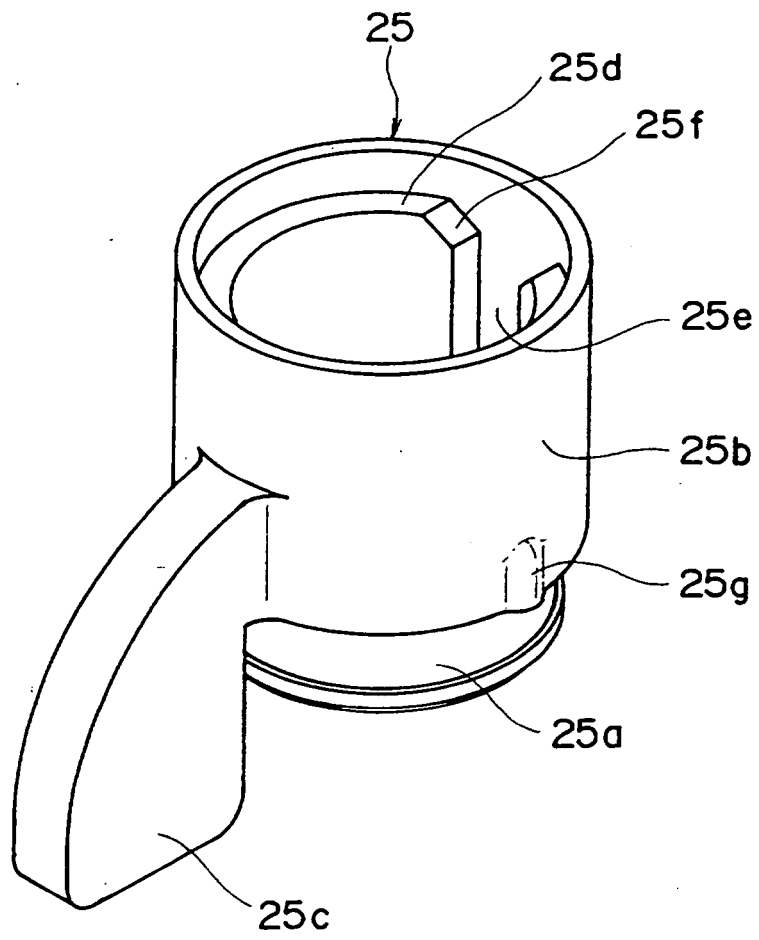

FIG.8A

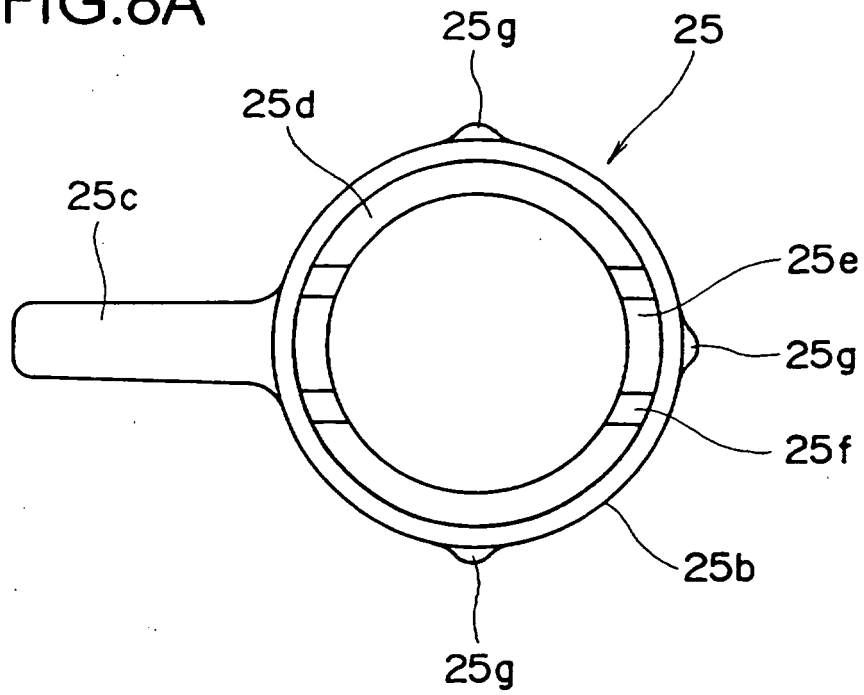

FIG.8B

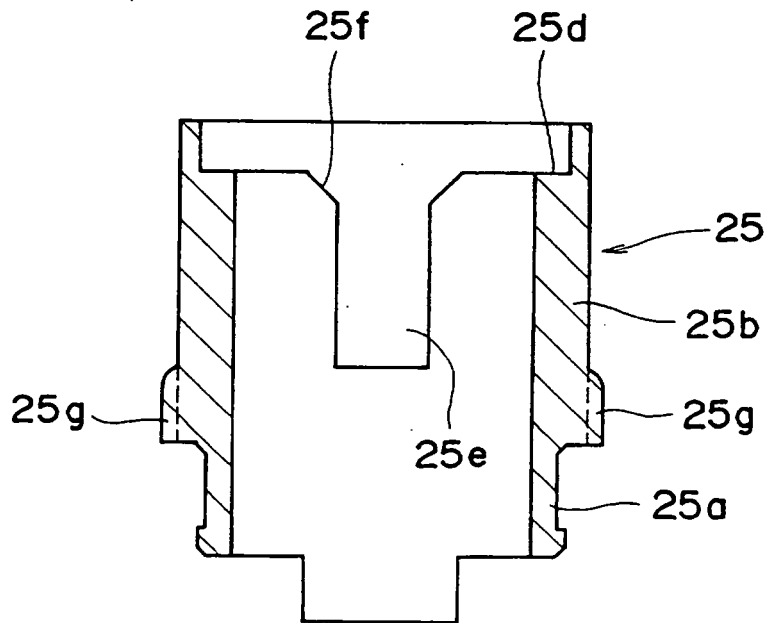

FIG.9

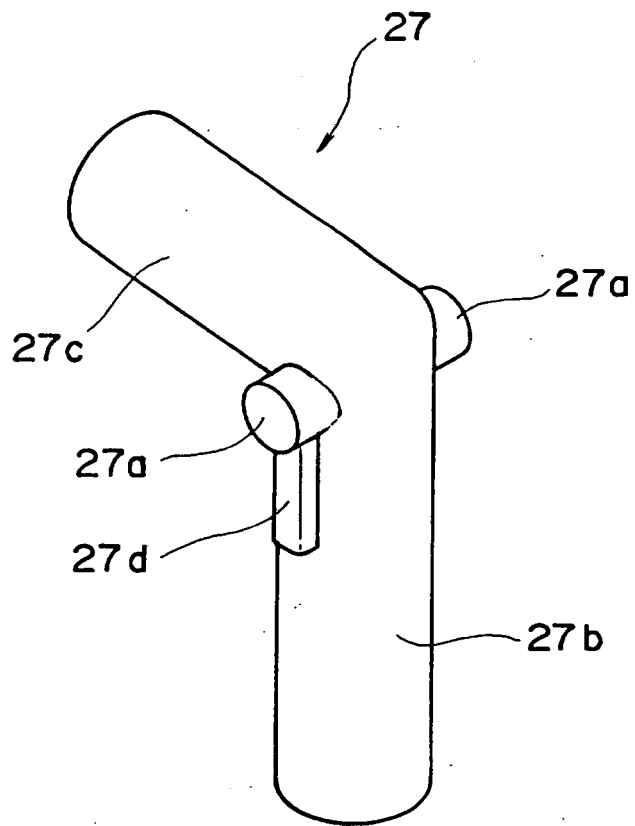
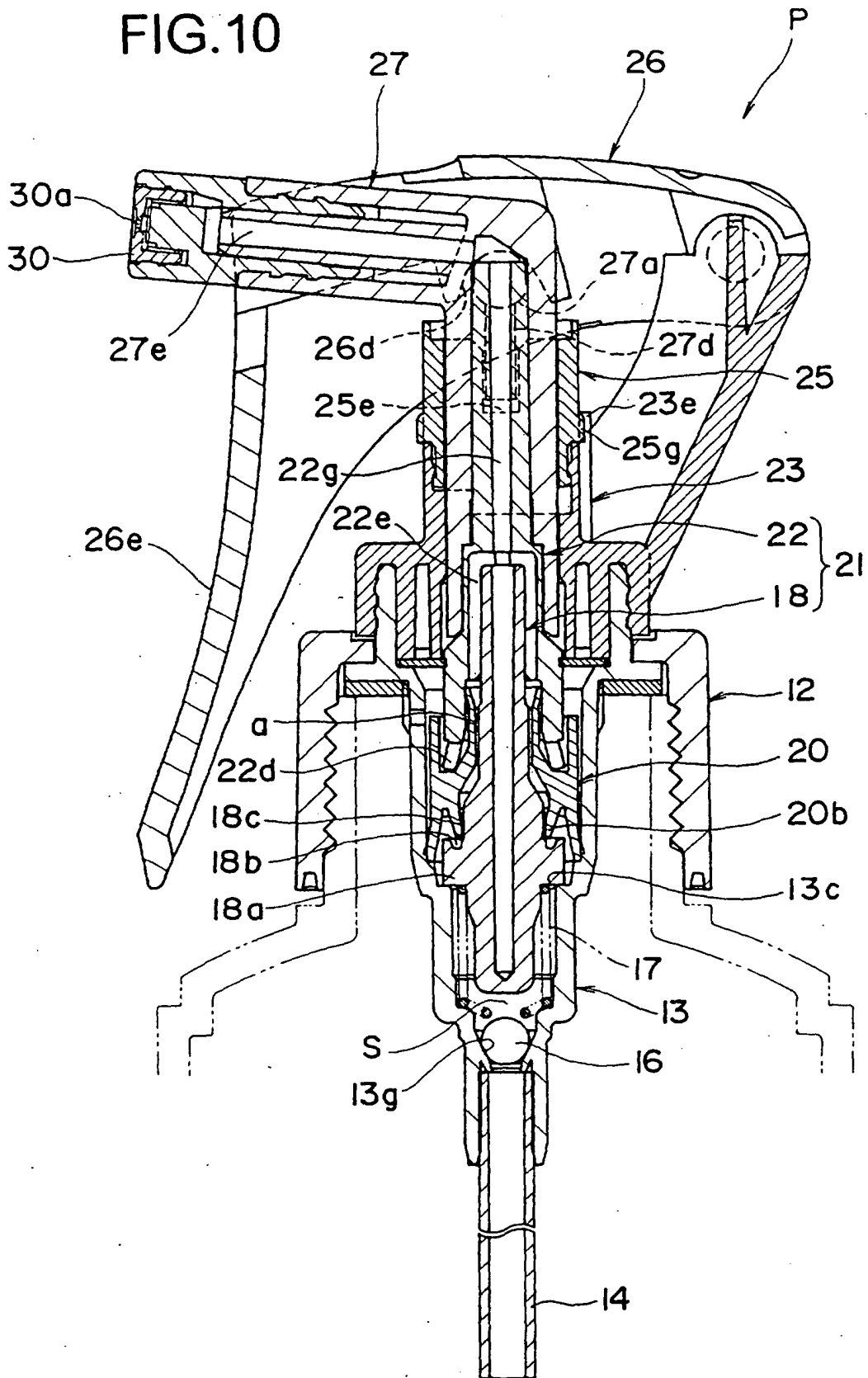

FIG.10



**REFERENCES CITED IN THE DESCRIPTION**

*This list of references cited by the applicant is for the reader's convenience only. It does not form part of the European patent document. Even though great care has been taken in compiling the references, errors or omissions cannot be excluded and the EPO disclaims all liability in this regard.*

**Patent documents cited in the description**

- JP 11076886 A [0001] [0005]