



(12) **EUROPEAN PATENT APPLICATION**

(43) Date of publication:
17.09.2003 Bulletin 2003/38

(51) Int Cl.7: **F21S 4/00, F21V 9/08,
F21S 10/02**

(21) Application number: **02251902.9**

(22) Date of filing: **16.03.2002**

(84) Designated Contracting States:
**AT BE CH CY DE DK ES FI FR GB GR IE IT LI LU
MC NL PT SE TR**
Designated Extension States:
AL LT LV MK RO SI

(72) Inventor: **Chen, Hsien-Te
Pei Tau, Taipei (TW)**

(74) Representative: **Dearing-Lambert, Peter Richard
Piper Lambert
120 Queens Road
Leicester LE2 3FL (GB)**

(71) Applicant: **Chen, Hsien-Te
Pei Tau, Taipei (TW)**

(54) **Colorful lamp strip**

(57) A lamp strip (10) with a heat shrinkage tube (28) provided with portions of different colors is disclosed. The lamp strip (10) includes an elongate bar (12) defining a plurality of bores (14) spaced along the bar (12). A light emitting element (18) is received and retained in each bore (14). The heat shrinkage tube (28) is provided with various colorful patterns (311~313) thereon or con-

stituted by sections (281~284, 291~293) of different colors, and is fit over and encompassing the elongate bar (12). A light-transmitting outer tube (30) made of plastics is then fit over the heat shrinkage tube (28). By means of the colorful portions of the heat shrinkage tube (28), the light emitted from the light emitting element (18) is colored and display colorful light patterns to an observer.

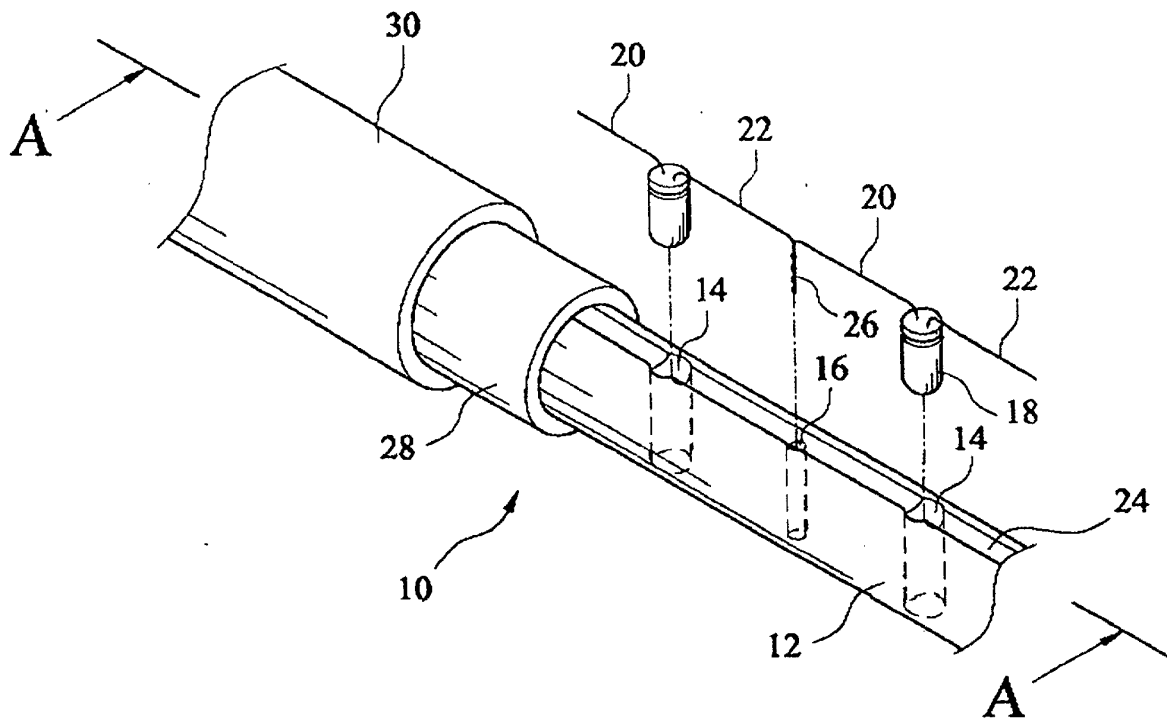

FIG.1

Description**BACKGROUND OF THE INVENTION**

1. Field of the Invention

[0001] The present invention relates generally to a lamp strip, and in particular to a lamp strip with a heat shrinkage tube provided with portions of different colors.

2. Description of the Prior Art

[0002] Lamp strips for decorative purposes are known. Examples include US Patent No. 6,244,726 B1 wherein a lamp strip comprising an elongate bar retaining a number of light bulbs and a transparent covering completely surrounding the bar and the light bulbs is disclosed. Since the covering functions for protection and water resistance, it provides no decorative purposes. Color of the light emitted from the bulbs cannot be changed unless the bulbs are changed.

[0003] It is thus desired to provide a lamp strip that gives off colorful light for consumer appealing.

SUMMARY OF THE INVENTION

[0004] An object of the present invention is thus to provide a lamp strip which gives off colorful light.

[0005] Another object of the present invention is to provide a lamp strip which is consumer appealing.

[0006] A further object of the present invention is to provide a lamp strip having excellent protection and water resistance.

[0007] To achieve the above objects, in accordance with the present invention, there is provided a lamp strip comprising an elongate bar defining a number of bores spaced along the bar. A cavity is defined in the bar between adjacent bores. A groove is defined in an outer surface of the bar and coextensive therewith. A light bulb or other light emitting element is received and retained in each bore. Each bulb has first and second wires received in and extending along the groove. The second wire of each bulb is jointed to the first wire of an adjacent bulb. The joint can be formed by simply twisting the wires together or by means of a connection element. The jointed portion of the wires is received in the corresponding cavity. A heat shrinkage tube having colorful patterns formed thereon or constituted by sections of different colors is tightly fit over and encompassing the light-transmitting inner layer. A light-transmitting, outer tube made of plastics is then fit over the heat shrinkage tube. By means of the colorful portions of the heat shrinkage tube, the light emitted from the light bulbs is colored and display colorful light patterns to an observer.

BRIEF DESCRIPTION OF THE DRAWINGS

[0008] The present invention will be apparent to those

skilled in the art by reading the following description of preferred embodiments thereof, with reference to the attached drawings, in which:

5 Figure 1 is a perspective view of a lamp strip constructed in accordance with the present invention; Figure 2 is a cross-sectional view of the lamp strip of the present invention, taken along line A-A of Figure 1;

10 Figure 3 is a perspective view of a heat shrinkage tube of the lamp strip in accordance with a first embodiment of the present invention;

15 Figure 4 is a perspective view of a heat shrinkage tube of the lamp strip in accordance with a second embodiment of the present invention; and

Figure 5 is a perspective view of a heat shrinkage tube of the lamp strip in accordance with a third embodiment of the present invention.

DETAILED DESCRIPTION OF THE PREFERRED EMBODIMENTS

[0009] With reference to the drawings and in particular to Figures 1 and 2, a lamp strip constructed in accordance with the present invention, generally designated with reference numeral 10, comprises an elongate bar 12 defining a number of bores 14 spaced along the bar 12. A cavity 16 is defined in the bar 12 between adjacent bores 14. A light emitting element 18, such as a light bulb, is received and retained in each bore 14. Each light emitting element 18 has first and second wires 20, 22.

[0010] A groove 24 is defined in an outer surface (not labeled) of the bar 12 and substantially coextensive therewith. The groove 24 is in communication with the bores 14 and the cavities 16. The wires 20, 22 of the light emitting elements 18 are received in and extending along the groove 24. The second wire 22 of each light emitting element 18 and the first wire 20 of an adjacent one of the light emitting elements 18 are jointed together at 26. The joint 26 can be done by simply twisting the wires 20, 22 together. Alternatively, a connection element may be used to connect and fix the wires 20, 22 together. The joint 26 is received in the cavity 16 located between the bores 14 of the two light emitting elements 18. A power source (not shown) supplies electricity to all the light emitting elements 18 through the wires 20, 22 and the joints 26 therebetween.

[0011] A heat shrinkage tube 28 in the form of an elongate light-transmitting inner tube is fit over the bar 12 and securely retains the light emitting elements 18 and the wires 20, 22 in position inside the bar 12. Preferably, the heat shrinkage tube 28 is made of a light-transmitting, heat-shrinkage material. An outer tube 30, preferably made of plastics, is tightly fit over the heat shrinkage tube 28 for protection and water resistance. The outer tube 30 is made of a light-transmitting material. Light emitting from the light emitting elements 18 are

projected through the heat shrinkage tube 28 and the outer tube 30.

[0012] The heat shrinkage tube 28 that surrounds the bar 12 serves to protect the bar 12 and the light emitting elements 18 from damage and humidity. Thus, with the bar 12 surrounded by both the heat shrinkage tube 28 and the outer tube 30, an excellent protection of the bar 12 and the light emitting elements 18 can be obtained.

[0013] Besides protection of the bar 12 and the light emitting elements 18, the heat shrinkage tube 28 also provides other functions. Figure 3 shows a first embodiment of the heat shrinkage tube 28 in accordance with the present invention. The heat shrinkage tube 28 shown in Figure 3 comprises a number of ring-like sections 281~284 arranged along the length of the heat shrinkage tube 28. The sections 281~284 are selectively provided with different colors whereby light from a single light source transmitting through the sections 281~284 becomes light of different colors.

[0014] Figure 4 shows a second embodiment of the heat shrinkage tube in accordance with the present invention which is designated with reference numeral 28' for distinction. The heat shrinkage tube 28' is comprised of a number of longitudinally extending strips 291~294 that are of different colors whereby light from a single light source transmitting through the strips 291~294 becomes light of different colors.

[0015] Figure 5 shows a third embodiment of the heat shrinkage tube in accordance with the present invention which is designated with reference numeral 28" for distinction. The heat shrinkage tube 28" forms patterns of different colors thereon. The patterns comprise spots 311~313 of different sizes and colors whereby light from a single light source transmitting through the spots 311~313 becomes light of different colors. It is apparent to those having ordinary skills to form any desired patterns of any shapes, sizes and colors on the heat shrinkage tube.

[0016] Although the present invention has been described with reference to the preferred embodiments thereof, it is apparent to those skilled in the art that a variety of modifications and changes may be made without departing from the scope of the present invention which is intended to be defined by the appended claims. For example, the heat shrinkage tube 28 can be integrally formed with the outer tube 30 for reducing the number of the parts.

Claims

1. A lamp strip comprising an elongate bar (12) defining a plurality of bores (14) thereon spaced along the bar (12), each of the bores (12) is received with a light emitting elements (18) for emitting light, **characterized in that** a light-transmitting inner tube (28) is fit over and surrounding the elongate bar (12), the inner layer (28) is provided with portions

of different colors, and a light-transmitting outer layer (30) is further tightly fit over and surrounding the light-transmitting inner tube (28).

2. The lamp strip as claimed in Claim 1, wherein the light-transmitting inner tube (28) is a heat shrinkage tube.
3. The lamp strip as claimed in Claim 1, wherein the light-transmitting inner tube (28) comprises a plurality of ring-like sections (281~284) of different colors arranged along the length of the light-transmitting inner tube (28).
4. The lamp strip as claimed in Claim 1, wherein the inner layer comprises a plurality of longitudinal strips (291~293) of different colors extending along the length of the light-transmitting inner tube (28).
5. The lamp strip as claimed in Claim 1, wherein the inner layer comprises patterns (311~313) of different colors formed thereon.
6. The lamp strip as claimed in Claim 1, wherein the elongate bar (12) has an outer surface in which a groove (24) is defined along the length of the elongate bar (12) and wherein each light emitting element (18) having a first wire (20) and a second wire (22) received in the groove (24) and partially extending along the groove (24).
7. The lamp strip as claimed in Claim 6, wherein the second wire (22) of each light emitting element (18) is jointed to the first wire (20) of an adjacent one of the light emitting elements (18).
8. The lamp strip as claimed in Claim 7, wherein a cavity (16) is defined in the bar (12) for receiving the joint (26) of the wires (20, 22) therein.
9. The lamp strip as claimed in Claim 1, wherein the light emitting element (18) is a light bulb.

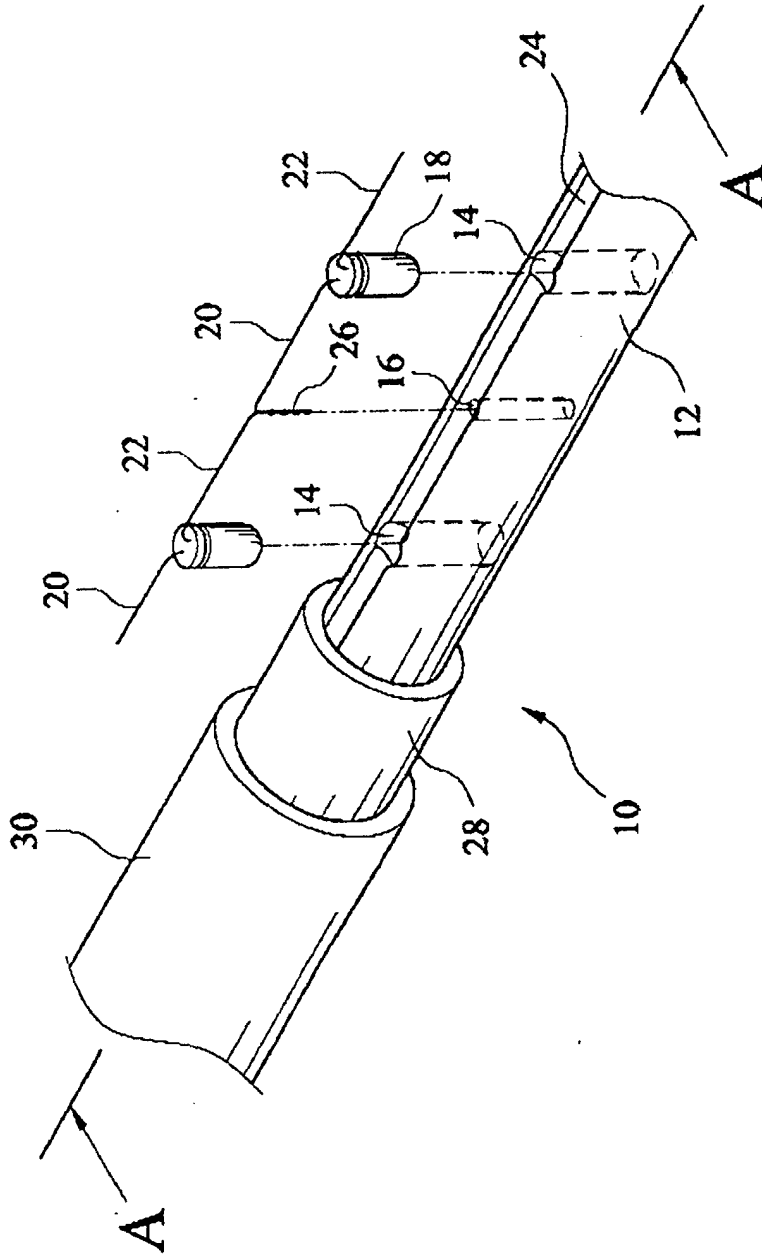

FIG.1

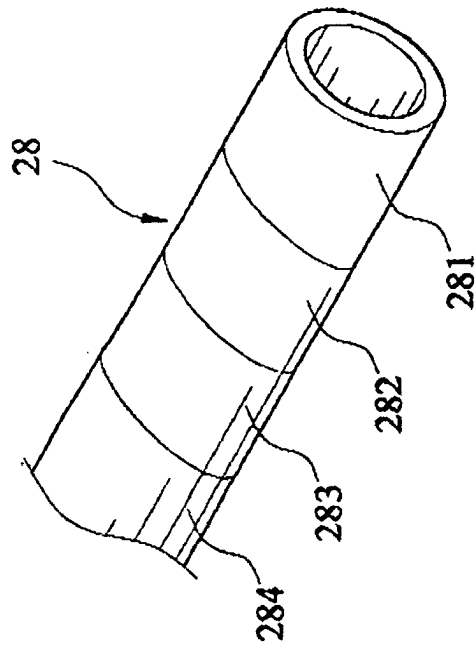

FIG.3

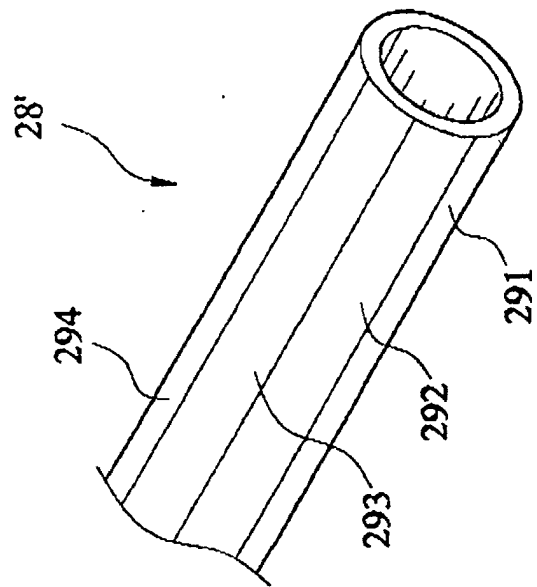

FIG.4

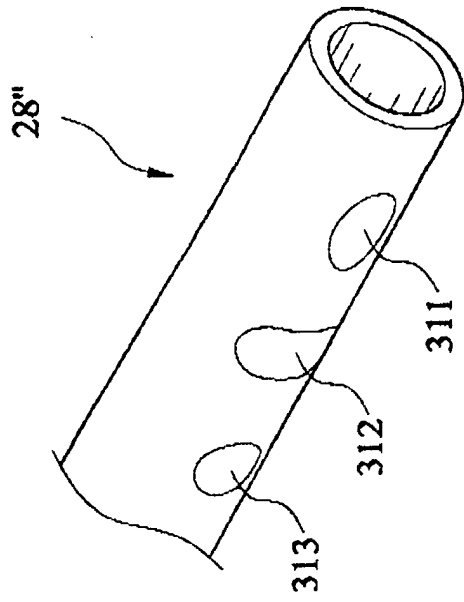

FIG.5



European Patent
Office

EUROPEAN SEARCH REPORT

Application Number
EP 02 25 1902

DOCUMENTS CONSIDERED TO BE RELEVANT			
Category	Citation of document with indication, where appropriate, of relevant passages	Relevant to claim	CLASSIFICATION OF THE APPLICATION (Int.Cl.7)
X	US 4 607 317 A (LIN TA-YEH) 19 August 1986 (1986-08-19) * column 2, line 7 - line 47 * * column 3, line 38 - line 45 * * column 3, line 58 - line 65 * * figures 1-3 *	1,3,6-9	F21S4/00 F21V9/08 F21S10/02
Y	---	4,5	
Y	GB 1 522 472 A (WAUMSLEY P) 23 August 1978 (1978-08-23) * page 1, line 67 - line 98 * * page 2, line 75 - line 121 * * figures 1-4 *	4,5	
A	---	1	
A	DE 200 12 457 U (SCHMIDT BERTOLT) 30 November 2000 (2000-11-30) * page 2, line 37 - line 42 * * figures 1-4 *	1,3	
A	US 6 149 285 A (CICARELLI GUS M J) 21 November 2000 (2000-11-21) * column 3, line 54 - column 4, line 47 * * column 5, line 44 - line 48 * * figures 1-3 *	1,5	TECHNICAL FIELDS SEARCHED (Int.Cl.7) F21S F21P F21V
The present search report has been drawn up for all claims			
Place of search THE HAGUE		Date of completion of the search 12 July 2002	Examiner Cosnard, D
CATEGORY OF CITED DOCUMENTS X : particularly relevant if taken alone Y : particularly relevant if combined with another document of the same category A : technological background O : non-written disclosure P : intermediate document		T : theory or principle underlying the invention E : earlier patent document, but published on, or after the filing date D : document cited in the application L : document cited for other reasons & : member of the same patent family, corresponding document	

EPO FORM 1503 03.82 (PO4C01)

**ANNEX TO THE EUROPEAN SEARCH REPORT
ON EUROPEAN PATENT APPLICATION NO.**

EP 02 25 1902

This annex lists the patent family members relating to the patent documents cited in the above-mentioned European search report. The members are as contained in the European Patent Office EDP file on
The European Patent Office is in no way liable for these particulars which are merely given for the purpose of information.

12-07-2002

Patent document cited in search report	Publication date	Patent family member(s)	Publication date
US 4607317 A	19-08-1986	NONE	
GB 1522472 A	23-08-1978	NONE	
DE 20012457 U	30-11-2000	DE 20012457 U1	30-11-2000
US 6149285 A	21-11-2000	NONE	

EPO FORM P0489

For more details about this annex : see Official Journal of the European Patent Office, No. 12/82