



(12) **EUROPEAN PATENT APPLICATION**

(88) Date of publication A3:
06.05.2004 Bulletin 2004/19

(51) Int Cl.7: **F02M 47/02**, F02M 51/06,
F02M 45/08

(43) Date of publication A2:
24.09.2003 Bulletin 2003/39

(21) Application number: **03005939.8**

(22) Date of filing: **17.03.2003**

(84) Designated Contracting States:
**AT BE BG CH CY CZ DE DK EE ES FI FR GB GR
HU IE IT LI LU MC NL PT RO SE SI SK TR**
Designated Extension States:
AL LT LV MK

- **Omae, Kazuhiro**
Toyota-shi, Aichi-ken, 471-8571 (JP)
- **Takaki, Niro**
Nishio-shi, Aichi, 445-0012 (JP)

(30) Priority: **18.03.2002 JP 2002074149**

- (74) Representative:
Leson, Thomas Johannes Alois, Dipl.-Ing.
Tiedtke-Bühling-Kinne & Partner GbR,
TBK-Patent,
Bavariaring 4
80336 München (DE)

(71) Applicant: **TOYOTA JIDOSHA KABUSHIKI
KAISHA**
Toyota-shi, Aichi 471-8571 (JP)

(72) Inventors:
• **Watanabe, Yoshimasa**
Toyota-shi, Aichi-ken, 471-8571 (JP)

(54) **Fuel injection valve**

(57) A fuel injection valve (1) provided with a control valve (8) which is displaced in order to control a pressure within a pressure chamber (5) acting upon a jet hole valve (4), an actuator (17) which generates an operation force for displacing the control valve (8), and elastic support means (22) which elastically supports the control valve in resistance to the operation force. The actuator (17) can change the operation force by controlling a control amount, and the elastic support means (22) is displaced along with the control valve (8) in accordance with increase of the operation force. When the control valve (8) is displaced to a chosen intermediate position it abuts with an abutting member (23). This abutting member (23) is pushed by a set pushing force, generated by an elastic member (24) which is separate from the elastic support means (23), which acts in the opposite direction to the operation force prior to the displacement of the abutting member (23). By structuring the fuel injection valve (1) in this way, it is possible to accurately control the control valve (8) such that it has the chosen intermediate displacement.

FIG. 1

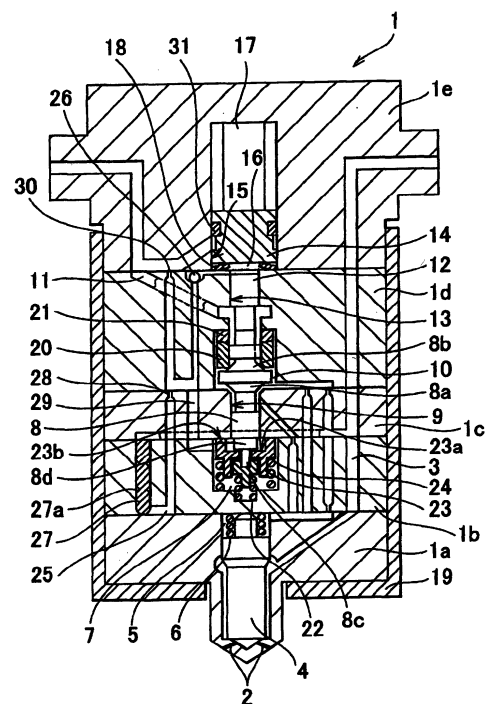



European Patent
Office

EUROPEAN SEARCH REPORT

Application Number
EP 03 00 5939

DOCUMENTS CONSIDERED TO BE RELEVANT			
Category	Citation of document with indication, where appropriate, of relevant passages	Relevant to claim	CLASSIFICATION OF THE APPLICATION (Int.Cl.7)
P,X	DE 102 25 209 A (DENSO CORP) 9 January 2003 (2003-01-09) * figures 1,2 *	1	F02M47/02 F02M51/06 F02M45/08

A	EP 1 041 272 A (DELPHI TECH INC) 4 October 2000 (2000-10-04) * figures 1,2 *	1	

D,A	EP 0 816 670 A (SIEMENS AUTOMOTIVE CORP LP) 7 January 1998 (1998-01-07) * figures 1,2 *	1	

The present search report has been drawn up for all claims			
Place of search MUNICH		Date of completion of the search 10 March 2004	Examiner Jackson, S
CATEGORY OF CITED DOCUMENTS X : particularly relevant if taken alone Y : particularly relevant if combined with another document of the same category A : technological background O : non-written disclosure P : intermediate document		T : theory or principle underlying the invention E : earlier patent document, but published on, or after the filing date D : document cited in the application L : document cited for other reasons & : member of the same patent family, corresponding document	

EPO FORM 1503 03.82 (P04C01)

**ANNEX TO THE EUROPEAN SEARCH REPORT
ON EUROPEAN PATENT APPLICATION NO.**

EP 03 00 5939

This annex lists the patent family members relating to the patent documents cited in the above-mentioned European search report. The members are as contained in the European Patent Office EDP file on
The European Patent Office is in no way liable for these particulars which are merely given for the purpose of information.

10-03-2004

Patent document cited in search report		Publication date	Patent family member(s)	Publication date
DE 10225209	A	09-01-2003	JP 2002364483 A	18-12-2002
			DE 10225209 A1	09-01-2003

EP 1041272	A	04-10-2000	EP 1041272 A2	04-10-2000
			EP 1338788 A1	27-08-2003
			US 6471142 B1	29-10-2002

EP 0816670	A	07-01-1998	US 5779149 A	14-07-1998
			DE 69708396 D1	03-01-2002
			DE 69708396 T2	23-05-2002
			EP 0816670 A1	07-01-1998

EPO FORM P0159

For more details about this annex : see Official Journal of the European Patent Office, No. 12/82