



(12) **EUROPEAN PATENT APPLICATION**
published in accordance with Art. 158(3) EPC

(43) Date of publication:
29.10.2003 Bulletin 2003/44

(51) Int Cl.7: **B66B 5/02, B66B 7/12**

(21) Application number: **00979984.2**

(86) International application number:
PCT/JP00/08673

(22) Date of filing: **07.12.2000**

(87) International publication number:
WO 02/046082 (13.06.2002 Gazette 2002/24)

(84) Designated Contracting States:
**AT BE CH CY DE DK ES FI FR GB GR IE IT LI LU
MC NL PT SE TR**
Designated Extension States:
AL LT LV MK RO SI

(72) Inventor: **TAKAGI, Hiroyuki**
Chiyoda-ku, Tokyo 100-8310 (JP)

(71) Applicant: **MITSUBISHI DENKI KABUSHIKI
KAISHA**
Tokyo 100-8310 (JP)

(74) Representative: **HOFFMANN - EITLÉ**
Patent- und Rechtsanwälte
Arabellastrasse 4
81925 München (DE)

(54) **ELEVATOR MAIN ROPE ELONGATION SENSOR**

(57) In an elevator main rope elongation detector apparatus, electrical resistance of an electrically-conductive filament integrated into a main rope is measured by an electrical resistance measuring apparatus. A determining means determines whether a measured value from the electrical resistance measuring apparatus is within a preset normal range. When the measured value is determined by the determining means to be outside the preset normal range, a warning is issued by a warning means.

FIG. 1

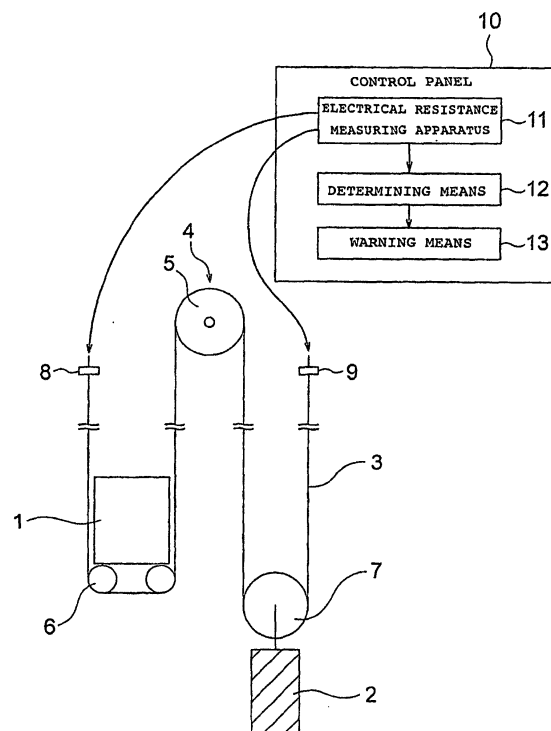

Description

TECHNICAL FIELD

[0001] The present invention relates to an elevator main rope elongation detector apparatus disposed in an elevator in which a car is suspended inside a hoistway by a main rope made of a synthetic fiber rope, the elevator main rope elongation detector apparatus detecting elongation of the main rope.

BACKGROUND ART

[0002] Generally, in a traction elevator, a car and a counterweight are suspended inside a hoistway by a main rope. A car buffer and a counterweight buffer are installed on a bottom portion of the hoistway. Furthermore, a clearance dimension between the counterweight and the counterweight buffer when the car is stopped at an uppermost floor is required to be constantly maintained at a specified value. However, the clearance dimension between the counterweight and the counterweight buffer is reduced by elongation of the main rope with the passage of time. In particular, when a main rope made of a synthetic fiber rope is used, the amount of elongation of the main rope is as much as twice that of a steel rope.

[0003] For this kind of elongation of the main rope, the clearance dimension between the counterweight and the counterweight buffer is conventionally measured during routine inspection. At this time, one maintenance worker drives the elevator, and another maintenance worker enters a pit in the hoistway and performs the measurement. Consequently, two maintenance workers are required, reducing work efficiency.

[0004] In answer to this, a method is disclosed in Japanese Patent Laid-Open No. HEI 6-56372, for example, in which the measurement is performed by one maintenance worker. However, in this method, since it is necessary for the maintenance worker to move the car to the uppermost floor and then go to the pit and check the results of the measurement, the operation is time-consuming, making work efficiency low.

DISCLOSURE OF THE INVENTION

[0005] The present invention aims to solve the above problems and an object of the present invention is to provide an elevator main rope elongation detector apparatus enabling elongation of a main rope made of a synthetic fiber rope to be detected simply and efficiently.

[0006] According to one aspect of the present invention, there is provided an elevator main rope elongation detector apparatus disposed in an elevator in which a car is suspended inside a hoistway by a main rope made of a synthetic fiber rope having a synthetic fiber strand and an electrically-conductive filament, the elevator main rope elongation detector apparatus detecting elongation of the main rope, wherein the elevator main rope elongation detector apparatus includes: an electrical resistance measuring apparatus for measuring electrical resistance in the electrically-conductive filament; a determining means for determining whether a measured value from the electrical resistance measuring apparatus is within a preset normal range; and a warning means for issuing a warning when the measured value is determined by the determining means to be outside the preset normal range.

gation of the main rope, wherein the elevator main rope elongation detector apparatus includes: an electrical resistance measuring apparatus for measuring electrical resistance in the electrically-conductive filament; a determining means for determining whether a measured value from the electrical resistance measuring apparatus is within a preset normal range; and a warning means for issuing a warning when the measured value is determined by the determining means to be outside the preset normal range.

BRIEF DESCRIPTION OF THE DRAWINGS

[0007]

Figure 1 is a structural diagram showing an elevator main rope elongation detector apparatus according to Embodiment 1 of the present invention;

Figure 2 is a structural diagram showing part of an elevator main rope elongation detector apparatus according to Embodiment 2 of the present invention;

Figure 3 is a structural diagram showing part of an elevator main rope elongation detector apparatus according to Embodiment 3 of the present invention;

Figure 4 is a structural diagram showing part of an elevator main rope elongation detector apparatus according to Embodiment 4 of the present invention; and

Figure 5 is a block diagram showing part of an elevator main rope elongation detector apparatus according to Embodiment 5 of the present invention.

BEST MODE FOR CARRYING OUT THE INVENTION

[0008] Preferred embodiments of the present invention will now be explained with reference to the drawings.

Embodiment 1

[0009] Figure 1 is a structural diagram showing an elevator main rope elongation detector apparatus according to Embodiment 1 of the present invention. In the figure, a car 1 and a counterweight 2 are suspended inside a hoistway by a main rope 3 made of a synthetic fiber rope. The main rope 3 includes: a plurality of synthetic fiber strands; and a plurality of carbon filaments functioning as electrically-conductive filaments integrated into at least some of these synthetic fiber strands over an entire length of each.

[0010] An intermediate portion of the main rope 3 is wound around a drive sheave 5 of a driving machine 4 disposed in an upper portion of the hoistway. The car 1 and the counterweight 2 are raised and lowered by means of a driving force from the driving machine 4. A pair of car suspension sheaves 6 around which the main

rope 3 is wound are disposed on a lower portion of the car 1. A counterweight suspension sheave 7 around which the main rope 3 is wound is disposed on an upper portion of the counterweight 2. First and second end portions of the main rope 3 are connected to respective

rope stops 8 and 9 in the upper portion of the hoistway. **[0011]** An electrical resistance measuring apparatus 11 for measuring electrical resistance in the carbon filaments integrated into the main rope 3 is disposed in a control panel 10 for controlling elevator operation. The electrical resistance measuring apparatus 11 is connected to first and second end portions of the carbon filaments.

[0012] Furthermore, disposed in the control panel 10 are: a determining means 12 for determining whether a measured value from the electrical resistance measuring apparatus 11 is within a preset normal range; and a warning means 13 for issuing a warning when the measured value is determined by the determining means 12 to be abnormal, i.e., outside the preset normal range. A main rope elongation detector apparatus according to Embodiment 1 includes the electrical resistance measuring apparatus 11, the determining means 12, and the warning means 13.

[0013] In a main rope elongation detector apparatus of this kind, the electrical resistance of the carbon filaments in the main rope 3 is measured by the electrical resistance measuring apparatus 11 when necessary. The carbon filaments are disposed over the entire length of the main rope 3, stretching in a similar manner to the main rope 3 when age-related elongation arises in the main rope 3. In other words, when elongation arises in the main rope 3, the entire length of the carbon filaments elongates, reducing cross-sectional area and increasing electrical resistance.

[0014] The measured value from the electrical resistance measuring apparatus 11 is monitored by the determining means 12 to determine whether there is any abnormality. If the measured value exceeds the preset normal range, an abnormality detection signal is sent to the warning means 13, whereby a warning is issued by the warning means 13. Then, any required action such as run-by adjustments or replacement of the main rope 3, etc., is undertaken by maintenance workers who receive the warning.

[0015] Using a main rope elongation detector apparatus of this kind, elongation of the main rope 3 can be detected simply and efficiently when necessary regardless of the position of the car 1. Furthermore, the elongation of the main rope 3 can be checked remotely and automatically, enabling reductions in costs required for maintenance inspections.

Embodiment 2

[0016] Figure 2 is a structural diagram showing part of an elevator main rope elongation detector apparatus according to Embodiment 2 of the present invention. In

the figure, the main rope 3 made of a synthetic fiber rope includes: a plurality of synthetic fiber strands 31 composed of an aramid resin or the like; and a plurality of carbon filaments 32 functioning as electrically-conductive filaments integrated into at least some of these synthetic fiber strands 31 over an entire length of each.

[0017] The electrical resistance measuring apparatus 11 is connected only to the first end portion of the main rope 3. At the second end portion of the main rope 3, the synthetic fiber strands 31 are bundled in pairs by means of end portion connectors 33. The carbon filaments 32 are also electrically connected in series in pairs by the end portion connectors 33.

[0018] A plurality of electrical component sets each including an electric power supply 35 for applying a voltage to the carbon filaments 32 through a resistor 34, a low-pass filter 36, and an analog-to-digital (A/D) converter 37 are disposed in the electrical resistance measuring apparatus 11. The rest of the construction is similar to that of Embodiment 1.

[0019] In a main rope elongation detector apparatus of this kind, because a plurality of pairs of the carbon filaments 32 are electrically connected at the second end portion of the main rope 3, the electrical resistance measuring apparatus 11 needs to be connected only at a single end portion of the main rope 3, facilitating wiring. Hence, in an elevator having one-to-one roping, for example, the electrical resistance measuring apparatus 11 needs to be connected only to a car end portion or to a counterweight end portion of the main rope 3, enabling the construction of the apparatus to be simplified.

Embodiment 3

[0020] Figure 3 is a structural diagram showing part of an elevator main rope elongation detector apparatus according to Embodiment 3 of the present invention. In this example, all of the carbon filaments 32 contained in one main rope 3 are electrically connected in series by a plurality of the end portion connectors 33. The total number of carbon filaments 32 is an even number (six in the figure), the electrical resistance measuring apparatus 11 being connected only at the first end portion of the main rope 3. The rest of the construction is similar to that of Embodiment 1.

[0021] In a main rope elongation detector apparatus of this kind, the electrical resistance measuring apparatus 11 needs to be connected only at a single end portion of the main rope 3, facilitating wiring. Hence, in an elevator having one-to-one roping, for example, the electrical resistance measuring apparatus 11 needs to be connected only to a car end portion or to a counterweight end portion of the main rope 3, enabling the construction of the apparatus to be simplified. Furthermore, since all of the carbon filaments 32 in one main rope 3 are electrically connected in series, it is not necessary to measure the electrical resistance for each of the carbon filaments 32 individually, enabling the construction of the

electrical resistance measuring apparatus 11 to be simplified.

Embodiment 4

[0022] In Embodiment 3, the carbon filaments 32 in one main rope 3 were electrically connected in series, but when a plurality of main ropes 3 are used, as shown in Figure 4 for example, the construction of the electrical resistance measuring apparatus 11 can be further simplified by electrically connecting the carbon filaments 32 in series over the plurality of main ropes 3.

Embodiment 5

[0023] Figure 5 is a block diagram showing part of an elevator main rope elongation detector apparatus according to Embodiment 5 of the present invention. In the figure, signals from the electrical resistance measuring apparatus 11, a temperature detector apparatus 21, and a humidity detector apparatus 22 are input into a central processing unit (CPU) 14 of the determining means 12 through input circuits 15 and 16. The temperature detector apparatus 21 detects temperature inside the hoistway, outputting that information to the determining means 12. The humidity detector apparatus 22 detects humidity inside the hoistway, outputting that information to the determining means 12.

[0024] A memory 17 for storing data such as set values for comparison with the measured value, correction factors for temperature and humidity, etc., is disposed in the determining means 12. When the measured value is determined by the CPU 14 to be abnormal, an abnormality detection signal is output to the warning means 13 through an output circuit 18.

[0025] Hence, detecting precision for elongation of the main rope 3 can be improved by making a decision based not merely on a comparison between set values and the measured value, but also considering expansion and contraction of the main rope 3 due to temperature and humidity inside the hoistway.

[0026] Furthermore, abnormality in the amount of elongation may also be determined by storing an initial electrical resistance in the memory 17 and comparing the measured value with this initial electrical resistance, enabling the detecting precision to be improved by eliminating the effects of initial irregularities in the main rope 3 and the carbon filaments 32.

[0027] In addition, by storing the measured values of electrical resistance in the memory 17, abnormality in the amount of elongation may also be determined from a mean value for a plurality of measured values, enabling the detecting precision to be improved by eliminating the effects of measurement errors.

[0028] Moreover, in the above examples, the electrical resistance in a plurality of carbon filaments 32 is measured in one main rope 3, but the elongation of the main rope 3 can be detected by measuring the electrical

resistance in just one or more of the carbon filaments 32. However, reliability can be improved by measuring the electrical resistance in a plurality of the carbon filaments 32.

[0029] Furthermore, in the above examples, carbon filaments 32 are shown as the electrically-conductive filaments, but the filaments may also be composed of any other electrically-conductive material.

[0030] In addition, in the above examples, the main rope elongation detector apparatus is disposed inside the control panel 10, but the main rope elongation detector apparatus may also be disposed on the car 1 or the counterweight 2 with the abnormality detection signal being sent to the control panel 10.

[0031] Still furthermore, in the electrical resistance measuring apparatus and the determining means, the electrical resistance may also be sought as a numerical value and determined directly, or may also be determined indirectly by measuring a voltage when a predetermined electric current is applied and determining whether that voltage is within a normal range.

Claims

1. An elevator main rope elongation detector apparatus disposed in an elevator in which a car is suspended inside a hoistway by a main rope made of a synthetic fiber rope having a synthetic fiber strand and an electrically-conductive filament, said elevator main rope elongation detector apparatus detecting elongation of said main rope, wherein said elevator main rope elongation detector apparatus comprises:

an electrical resistance measuring apparatus for measuring electrical resistance in said electrically-conductive filament;
a determining means for determining whether a measured value from said electrical resistance measuring apparatus is within a preset normal range; and
a warning means for issuing a warning when said measured value is determined by said determining means to be outside said preset normal range.

2. The elevator main rope elongation detector apparatus according to Claim 1 wherein an even number of said electrically-conductive filaments is contained in said main rope so as to be grouped into pairs, said electrically-conductive filaments in each of said pairs being electrically connected to each other in series, said electrical resistance measuring apparatus being connected to only one end portion of said main rope.

3. The elevator main rope elongation detector appa-

ratus according to Claim 2 wherein all of said electrically-conductive filaments contained in said main rope are electrically connected to each other in series.

5

4. The elevator main rope elongation detector apparatus according to Claim 1 wherein said car is suspended by a plurality of said main ropes, said electrically-conductive filaments contained in said main ropes being electrically connected to each other in series, and said electrical resistance measuring apparatus being connected to only one end portion of said plurality of main ropes.

10

5. The elevator main rope elongation detector apparatus according to Claim 1 wherein a temperature detector apparatus for detecting temperature inside said hoistway is connected to said determining means, determination on said measured value being performed by said determining means in response to information from said temperature detector apparatus.

15

20

6. The elevator main rope elongation detector apparatus according to Claim 1 wherein a humidity detector apparatus for detecting humidity inside said hoistway is connected to said determining means, determination on said measured value being performed by said determining means in response to information from said humidity detector apparatus.

25

30

7. The elevator main rope elongation detector apparatus according to Claim 1 wherein a memory for storing an initial electrical resistance for said electrically-conductive filament is disposed in said determining means, determination on said measured value being performed by said determining means by a comparison of said measured value with said initial electrical resistance.

35

40

8. The elevator main rope elongation detector apparatus according to Claim 1 wherein a memory for storing a plurality of said measured values is disposed in said determining means, determination being performed by said determining means using a mean value of said plurality of measured values.

45

50

55

FIG. 1

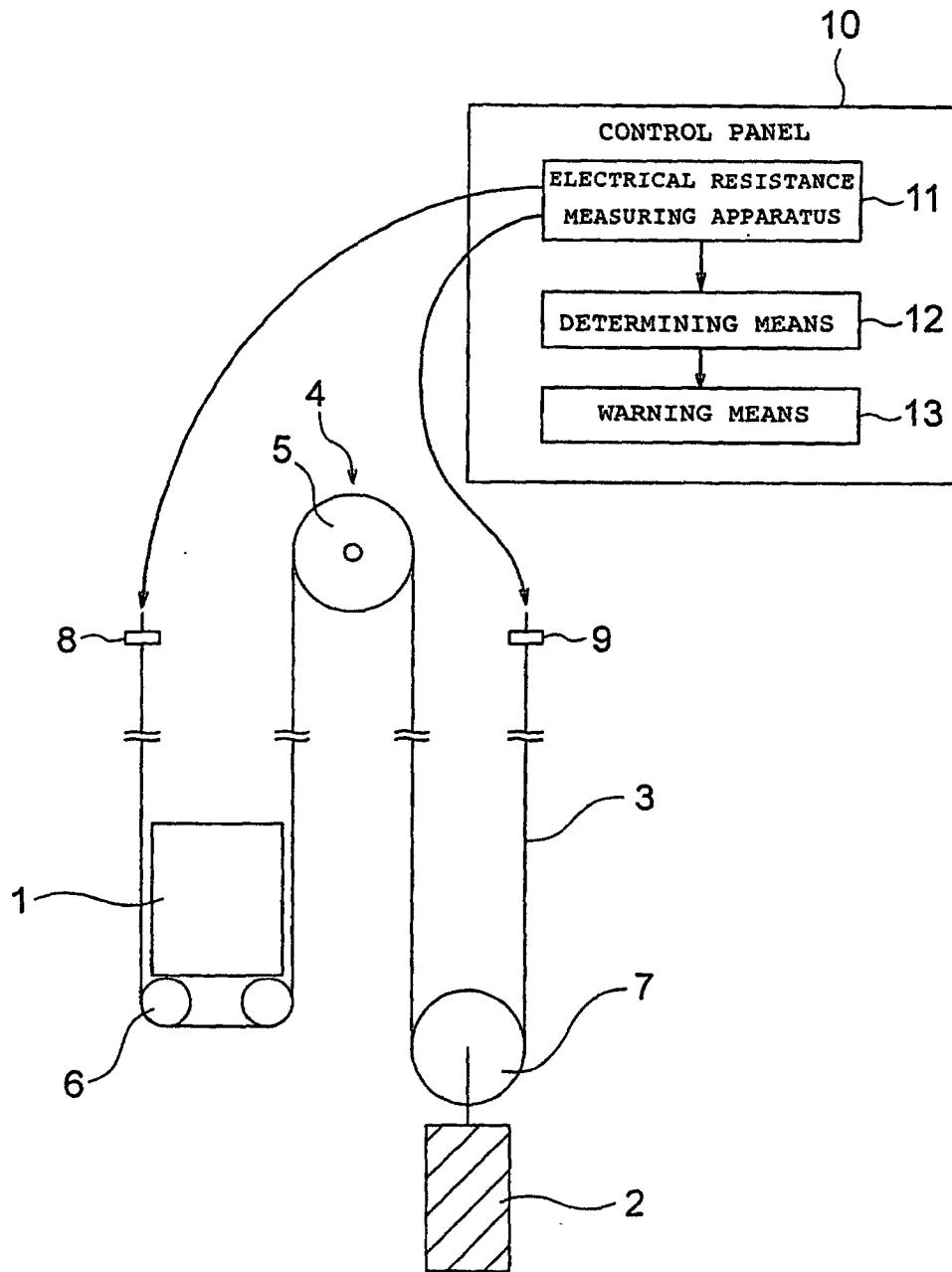

FIG. 2

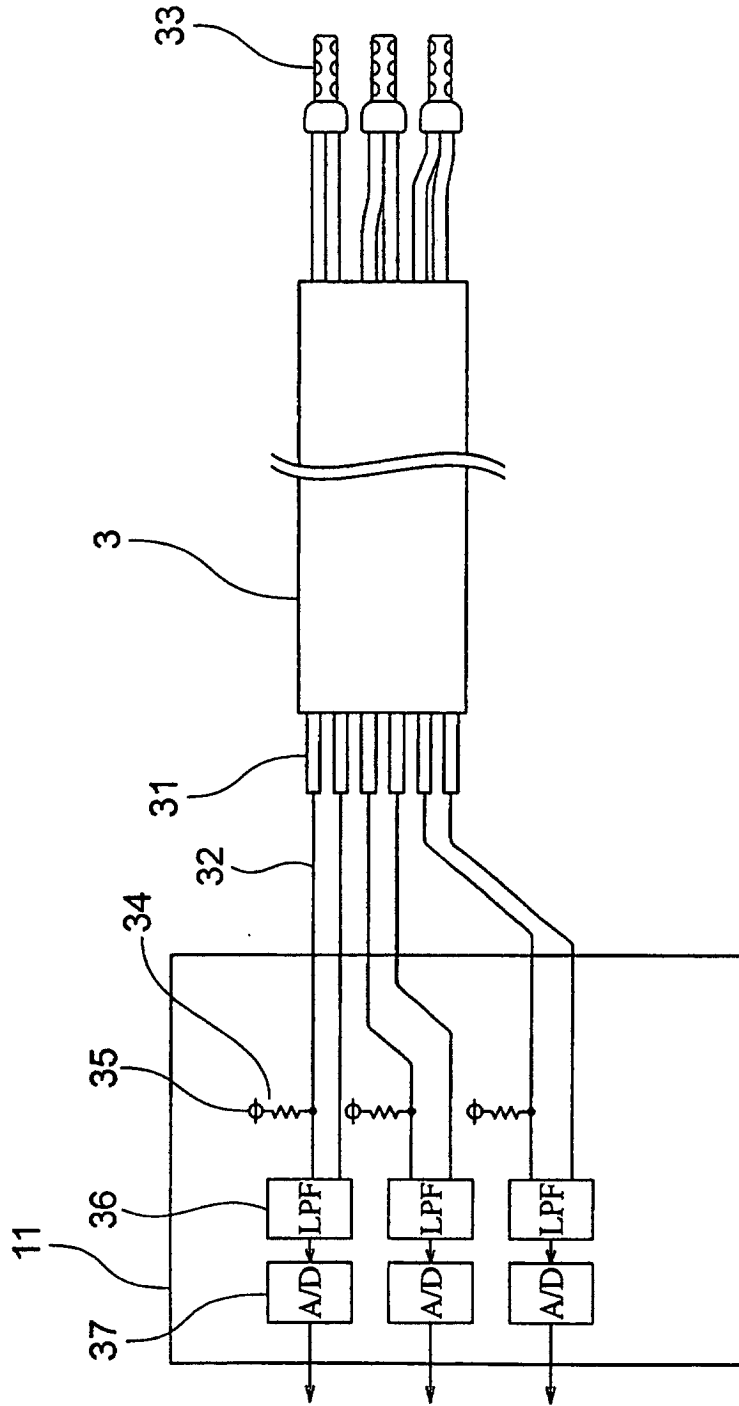

FIG. 3

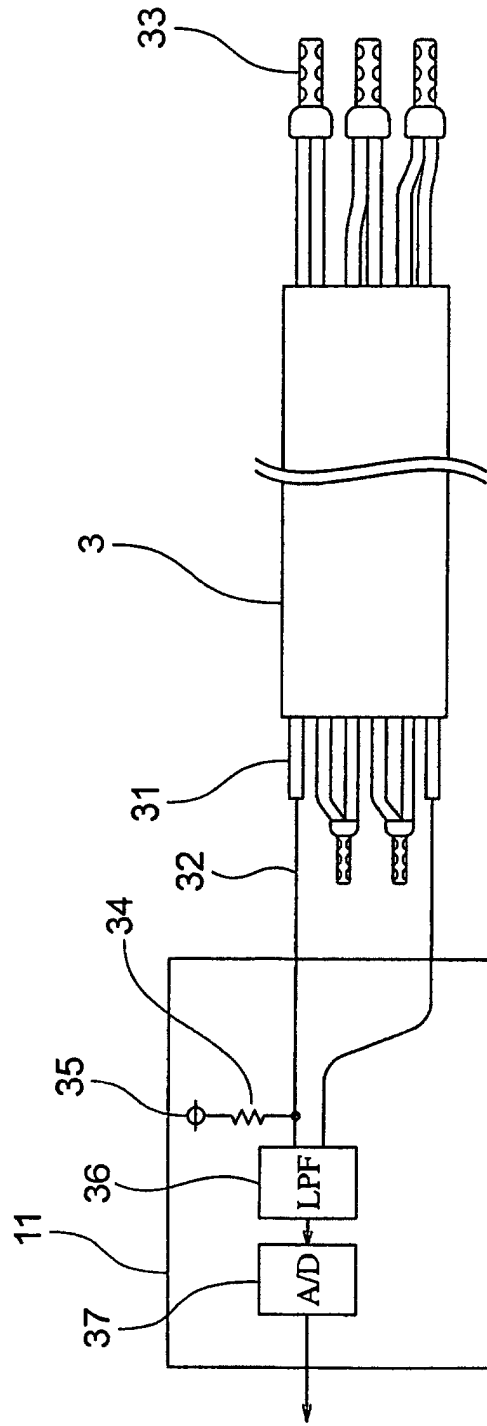

FIG. 4

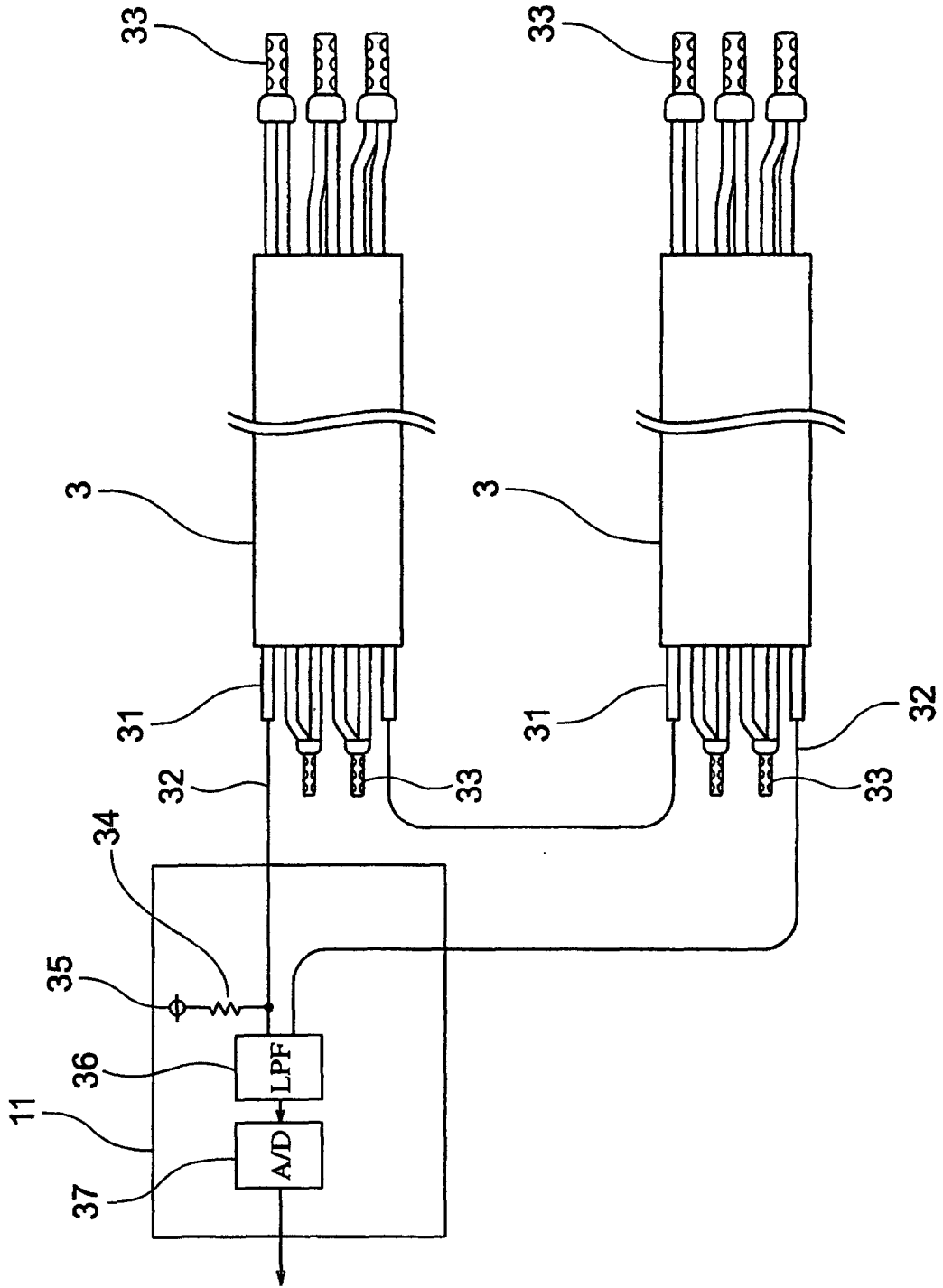
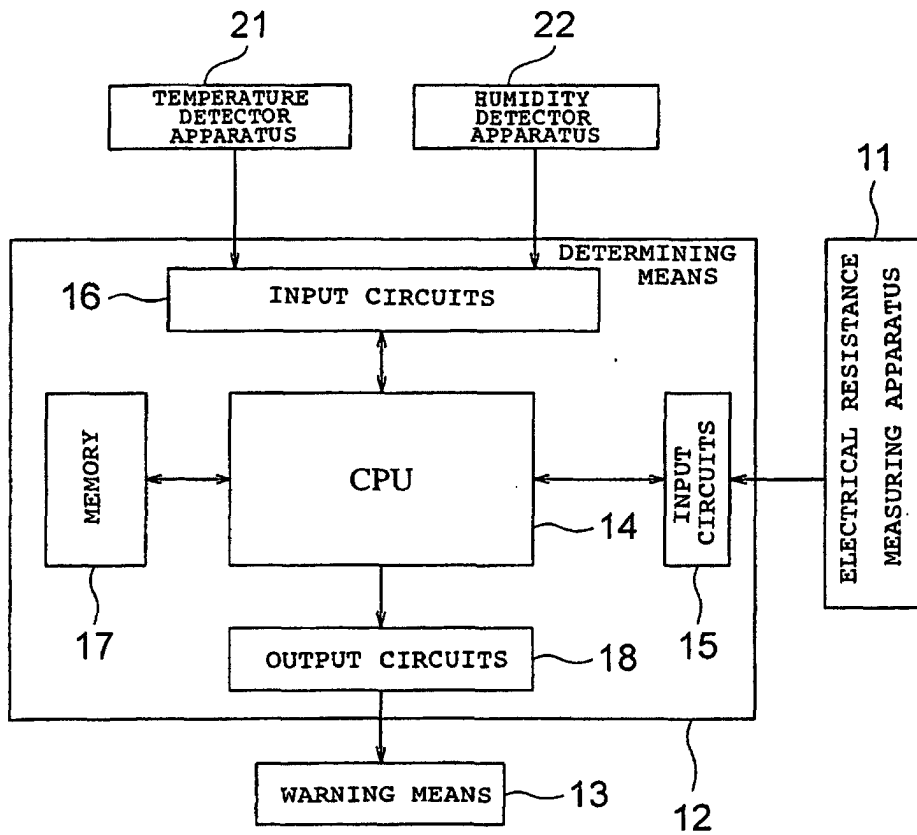

FIG. 5



INTERNATIONAL SEARCH REPORT

International application No.

PCT/JP00/08673

A. CLASSIFICATION OF SUBJECT MATTER Int.Cl. ⁷ B66B 5/02, B66B 7/12		
According to International Patent Classification (IPC) or to both national classification and IPC		
B. FIELDS SEARCHED		
Minimum documentation searched (classification system followed by classification symbols) Int.Cl. ⁷ B66B 1/00-B66B 7/12, D07B 1/00-D07B 1/22		
Documentation searched other than minimum documentation to the extent that such documents are included in the fields searched Jitsuyo Shinan Koho 1922-1996 Jitsuyo Shinan Toroku Koho 1996-2001 Kokai Jitsuyo Shinan Koho 1971-2001 Toroku Jitsuyo Shinan Koho 1994-2001		
Electronic data base consulted during the international search (name of data base and, where practicable, search terms used)		
C. DOCUMENTS CONSIDERED TO BE RELEVANT		
Category*	Citation of document, with indication, where appropriate, of the relevant passages	Relevant to claim No.
X	JP 8-261972 A (Inventio AG), 11 October, 1996 (11.10.1996),	1-4, 7
A	& EP 731209 A1 & CZ 9600649 A3 & AU 9645848 A & NO 9600880 A & CA 2169431 A & ZA 9601733 A & NZ 286035 A & CN 1134484 A & HU 9600548 A2 & BR 9600892 A & US 5834942 A & RU 2148117 C1	5-6, 8
A	GB 2152088 A (Bridon PLC), 31 July, 1985 (31.07.1985) (Family: none)	1-4
A	JP 5-338958 A (Mitsubishi Electric Corporation), 21 December, 1993 (21.12.1993), Par. No. [0004] (Family: none)	5-6
<input type="checkbox"/> Further documents are listed in the continuation of Box C. <input type="checkbox"/> See patent family annex.		
* Special categories of cited documents: "A" document defining the general state of the art which is not considered to be of particular relevance "E" earlier document but published on or after the international filing date "L" document which may throw doubts on priority claim(s) or which is cited to establish the publication date of another citation or other special reason (as specified) "O" document referring to an oral disclosure, use, exhibition or other means "P" document published prior to the international filing date but later than the priority date claimed	"T" later document published after the international filing date or priority date and not in conflict with the application but cited to understand the principle or theory underlying the invention "X" document of particular relevance; the claimed invention cannot be considered novel or cannot be considered to involve an inventive step when the document is taken alone "Y" document of particular relevance; the claimed invention cannot be considered to involve an inventive step when the document is combined with one or more other such documents, such combination being obvious to a person skilled in the art "&" document member of the same patent family	
Date of the actual completion of the international search 06 March, 2001 (06.03.01)	Date of mailing of the international search report 21 March, 2001 (21.03.01)	
Name and mailing address of the ISA/ Japanese Patent Office	Authorized officer	
Facsimile No.	Telephone No.	

Form PCT/ISA/210 (second sheet) (July 1992)