

(19)



Europäisches Patentamt
European Patent Office
Office européen des brevets



(11)

EP 1 361 344 B1

(12)

EUROPEAN PATENT SPECIFICATION

(45) Date of publication and mention
of the grant of the patent:
08.11.2006 Bulletin 2006/45

(51) Int Cl.:
F01L 13/06^(2006.01) F02M 25/07^(2006.01)

(21) Application number: **03010118.2**

(22) Date of filing: **05.05.2003**

(54) **A valve-actuating system for an exhaust gas recirculation system of an internal-combustion engine**

Ventilantriebsmechanismus für ein Abgasrückführungssystem einer Brennkraftmaschine

Dispositif de commande de soupapes pour un système de recirculation de gaz d'échappement d'un moteur à combustion interne

(84) Designated Contracting States:
**AT BE BG CH CY CZ DE DK EE ES FI FR GB GR
HU IE IT LI LU MC NL PT RO SE SI SK TR**

(30) Priority: **07.05.2002 IT TO20020377**

(43) Date of publication of application:
12.11.2003 Bulletin 2003/46

(73) Proprietors:
• **IVECO S.p.A.**
10156 Torino (IT)
• **Iveco Motorenforschung AG**
CH-9320 Arbon (CH)

(72) Inventors:
• **Dellora, Giancarlo**
10129 Torino (IT)
• **Schmidt, Klaus Dieter**
8280 Kreuzlingen (CH)

(74) Representative: **Gervasi, Gemma**
Notarbartolo & Gervasi S.p.A.,
Corso di Porta Vittoria, 9
20122 Milano (IT)

(56) References cited:
DE-A- 19 807 351 US-A1- 2001 027 773
US-B1- 6 244 257 US-B1- 6 354 254

EP 1 361 344 B1

Note: Within nine months from the publication of the mention of the grant of the European patent, any person may give notice to the European Patent Office of opposition to the European patent granted. Notice of opposition shall be filed in a written reasoned statement. It shall not be deemed to have been filed until the opposition fee has been paid. (Art. 99(1) European Patent Convention).

Description

[0001] The present invention relates to a valve-actuating system for an exhaust gas recirculation system of an internal-combustion engine.

[0002] Internal-combustion engines are known which are provided with recirculating systems adapted to feed some of the burnt exhaust gases into the combustion chamber so as to modify the combustion conditions of the air/fuel mixture.

[0003] In fact, it is known that the presence of burnt gases contributes to an increase in the thermal inertia of the air/fuel mixture and thus to a reduction in the oxygen/fuel ratio and the combustion temperature of the mixture. In particular, the recirculation of exhaust gases contributes to a reduction in the emissions of nitrogen oxide (NO_x).

[0004] The recirculation operations described above are typically carried out according to two principal strategies and, in particular:

- the exhaust valves are partly open during the opening period of the inlet valves so that some of the exhaust gases present in the exhaust manifold are re-admitted into the combustion chamber; and
- the inlet valves are partly open during the opening period of the exhaust valves so that some of the exhaust gases are accommodated in the end portion of the exhaust manifold; the subsequent opening of the inlet valves allows the re-admission of the exhaust gases into the combustion chamber.

[0005] From a mechanical point of view, the partial opening of the exhaust/inlet valves is effected by an actuating system in which the camshaft is provided with main lobes adapted to bring about full opening of the valves and lobes of reduced size which are adapted to bring about partial opening of the valves which serve for the recirculation function.

[0006] Although the above-described recirculation systems are useful in many operating conditions, there are, however, operating conditions of the engine in which the recirculation of the exhaust gases may be harmful. In these operating conditions the recirculation may result in a non-optimum combustion condition of the air/fuel mixture, leading to the production of corrosive condensates which can attack essential components of the engine (cylinder barrels, pistons, piston rings and bearings).

[0007] Therefore, there is need to provide an actuating system which, in certain operating conditions, enables the exhaust gas recirculation system to be rendered inoperative.

[0008] US-B1-6354254 discloses a valve-actuating system for exhaust gas recirculation, in which a camshaft acts on a plurality of rockers for actuating valves, and has main lobes for inducing full valve opening to bring about the intake of air/fuel mixture or expulsion of exhausts, and has auxiliary lobes to induce partial valve

opening for exhaust gas recirculation; the system also comprises a valve clearance regulating device to vary the clearance between a first lower value, in which the valves are opened both by the main lobes and by the auxiliary lobes, and a second higher clearance value, in which the valves are opened by the main lobes alone.

[0009] The object of the present invention is achieved by a valve-actuating system for an exhaust gas recirculation system, as described in the attached claims.

[0010] The invention will now be described particularly with reference to the accompanying drawings which illustrate a preferred non-restrictive embodiment thereof, wherein:

Figure 1 illustrates a valve-actuating system for an exhaust gas recirculation system of an internal-combustion engine designed in accordance with the present invention, disposed in a first operating position, and

- Figure 2 illustrates the system in Figure 1 disposed in a second operating position.

[0011] In Figure 1 the reference numeral 1 generally denotes a valve-actuating system for an exhaust gas recirculation system of an internal-combustion engine.

[0012] In particular, the actuating system 1 comprises a camshaft 3 which acts on a plurality of rockers 5, each of which is used to actuate one or more valves 7 (in the example illustrated each rocker 5 actuates two valves 7 simultaneously) mounted in a cylinder head 9 (partly illustrated) of the engine. In particular, in the example illustrated, a first pair of valves 7 is used to feed the air/fuel mixture to the combustion chamber 10, while a second pair of valves (not shown) is used to expel the burnt gases from the combustion chamber 10.

[0013] More particularly, each rocker 5 has a first end portion 12 which is provided with a roller 13 able to rotate about an axis 14 and adapted to come into contact with respective lobes (to be described in detail below) of the camshaft 3.

[0014] The rocker 5 has a second end portion 16 which is provided with a Y-shaped cross-member 17 adapted to bring about the opening of a first pair of valves 7. The cross-member 17 comprises a substantially trapezium-shaped central portion 18 securely attached to the portion 16 and two integral parallelepipedal extensions 19 which have respective rectangular flat end walls 20 which are mutually coplanar and are turned towards the valves 7.

[0015] Each valve 7 has a stem 22 which extends from a valve base and which terminates in a substantially flat end portion 22a.

[0016] The valve 7 is coupled (in known manner) with a coil spring 25 coaxial to the stem 22 and adapted to bring the valve 7 into a closed position.

[0017] The camshaft 3 has main lobes 30 which are adapted to bring about full opening of a pair of valves 7 so as to cause the admission of the air/fuel mixture into the combustion chamber 10 and the expulsion of the ex-

haust gases from the combustion chamber 10. The camshaft 3 is also provided with auxiliary lobes 31 adapted to bring about partial opening of a pair of valves 7 so as to provide an exhaust gas recirculation function.

[0018] In particular, the main lobes 30 and the auxiliary lobes 31 can be arranged on the camshaft 3 according to a first angular arrangement (of known type), in accordance with which the exhaust valves 7 are partly opened during the opening period of the inlet valves 7 so that some of the exhaust gases present in the exhaust manifold are re-admitted into the combustion chamber 10.

[0019] Alternatively, the main lobes 30 and the auxiliary lobes 31 can be arranged on the camshaft 3 according to a second angular arrangement (of known type), in accordance with which the inlet valves 7 are partly opened during the opening period of the exhaust valves 7 so that some of the exhaust gases are accommodated in the end portion of the intake manifold; the inlet valves are thus closed and their subsequent opening enables the exhaust gases to be re-admitted into the combustion chamber 10.

[0020] Each rectangular wall 20 of the Y-shaped cross-member 17 is situated opposite a respective end portion 22a of the valve 7 is spaced apart therefrom by a distance D (clearance) which is measured when the roller 13 is not situated in contact with any of the main lobes 30 or auxiliary lobes 31.

[0021] In particular, according to the present invention a device is provided for regulating the valve clearance 35, which is adapted to vary the clearance between at least:

- a first lower clearance value D1 (Figure 2), in which the rocking movement of the camshaft 3 induced by the angular movement of the main lobes 30 and the auxiliary lobes 31 is transmitted to the valves 7 which are thus caused to be opened both by the main lobes 30 and by the auxiliary lobes 31; and
- a second higher clearance value D2 (Figure 1), in which only the rocking movement of the camshaft 3 induced by the angular movement of the main lobes 30 is transmitted to the valves 7 which are thus caused to be opened by the main lobes 30 alone.

[0022] More particularly, the valve-clearance regulating device 35 comprises a bush 35 bounded by a cylindrical outer surface accommodated in a circular through-opening 40 formed in a central portion of the rocker 5 and coaxial to a first axis 42. The cylindrical bush 38 has a cylindrical central through-opening 43 which is coaxial to a second axis 38 which is not coincident with the axis 42 and which is spaced apart from the latter by a predetermined radial distance.

[0023] The cylindrical central opening 43 accommodates a shaft 50, the end portions of which (not shown) are securely attached to the cylinder head of the engine. Furthermore, the cylindrical bush 38 is connected by a pivotally mounted extension 52 with the end portion of

an output member of an actuator 54.

[0024] In operation, to bring about the recirculation of exhaust gas the actuator 54 disposes the bush 38 with respect to the shaft 50 in a first angular position (shown in Figure 2), in which the valve clearance assumes the above-mentioned lower value D1. The angular movement of the main lobes 30 and of the auxiliary lobes 31 of the camshaft on the roller 13 induces the rotation of the rocker 5 about the bush 38; in particular, the main lobes bring about angular displacements of the rocker 5 which are greater in extent than the angular displacements induced by the auxiliary lobes 31. Owing to the reduced clearance value, both of the angular displacements are of sufficient amplitude to bring about the contact between the cross-member 17 and the end portions 22a of the valves 7; in this way the valves 7 are caused to open both by the main lobes 30 and by the auxiliary lobes 31.

[0025] To render the exhaust gas recirculation inoperative, the actuator 54 places the bush 38 with respect to the shaft 50 in a second angular position (shown in Figure 1), in which the valve clearance assumes the above-mentioned higher value D2. As stated above, the angular movement of the main lobes 30 and the auxiliary lobes 31 of the camshaft on the roller 13 brings about the rotation of the rocker 5 about the bush 38. Because of the higher clearance value, only the angular displacements induced by the main lobes 30 are of sufficient amplitude to bring about the contact between the cross-member 17 and the end portions 22a of the valves 7; in this way the valves 7 are actuated by the main lobes 30 alone. Since the exhaust gas recirculation is brought about by the opening induced by means of the auxiliary lobes 31, this function is rendered inoperative.

[0026] The advantages achieved with the present invention are apparent from the foregoing, in that it provides an actuating system which, based on a simple operative control imparted to the actuator 54, enables the exhaust gas recirculation system to be rendered inoperative/operative.

[0027] Finally, it is evident how modifications and variations can be made to the valve actuating system for an exhaust gas recirculation system described and illustrated but without departing from the scope of protection of the present invention.

Claims

1. A valve-actuating system for an exhaust gas recirculation system, in which a camshaft (3) acts on a plurality of rockers (5) used to actuate valves (7); the camshaft (3) having main lobes (30) used to induce full valve opening so as to bring about the intake of the air/fuel mixture or the expulsion of the exhaust gases; the camshaft further having auxiliary lobes (31) used to induce partial valve opening serving for an exhaust

gas recirculation function,
the valve actuating system comprising a valve clearance regulating device adapted to vary said clearance between at least:

a first lower clearance value (D1) in which the rocking movement of the rocker (5) caused by the angular movement of the main lobes and of the auxiliary lobes is transmitted to the valves (7) which are thus caused to open both by the main lobes (30) and by the auxiliary lobes (31); and

a second higher clearance value (D2) in which only the rocking movement of the rocker (5) caused by the angular movement of the main lobes (30) is transmitted to the valves (7) which are thus induced to open by the main lobes (30) alone, **characterised in that**

said valve clearance regulating device comprises a bushing (38) accommodated in a through-opening (40) formed in a central portion of said rocker (5) and coaxial to a first axis (42);

said bush (38) having a central through-opening (43) which is coaxial to a second axis (48) which is separated from the axis (42) and which accommodates a shaft (50) carried by said engine; it being possible for said bush (38) to be disposed with respect to said shaft (50) in a first angular arrangement in which the valve clearance assumes said first lower value (D1) :

it further being possible for said bush (38) to be disposed with respect to said shaft (50) in a second angular arrangement in which the valve clearance assume said second higher value (D2).

2. A system according to claim 1, in which actuating (54) means are provided which are provided with a movable output member pivotally mounted on an extension which extends from said bush (38).

Patentansprüche

1. Ventilbetätigungssystem für ein Abgasrückführungssystem, bei dem eine Nockenwelle (3) auf mehrere Kipphebel (5) einwirkt, die dazu verwendet werden, Ventile (7) zu betätigen; wobei die Nockenwelle (3) Hauptnocken (30) aufweist, die dazu verwendet werden, eine volle Ventilöffnung einzuleiten, um den Einlass des Luft/Kraftstoff-Gemisches oder den Ausstoß der Abgase zu bewirken; wobei die Nockenwelle darüber hinaus Zusatznocken (31) umfasst, die dazu verwendet werden, eine partielle Ventilöffnung einzuleiten, die eine Abgasrückführungsfunktion hat, wobei das Ventilbetätigungssystem eine Ventilspiel-

regelvorrichtung umfasst, die geeignet ist, das Spiel zu verändern zwischen zumindest:

einem ersten unteren Spielwert (D1), bei dem die Kippbewegung des Kipphebels (5), die durch die Winkelbewegung der Hauptnocken und der Zusatznocken hervorgerufen wird, auf die Ventile (7) übertragen wird, die somit dazu gebracht werden, sich beide durch die Hauptnocken (30) und die Zusatznocken (31) zu öffnen; und

einem zweiten höheren Spielwert (D2), bei dem nur die Kippbewegung des Kipphebels (5), die durch die Winkelbewegung der Hauptnocken (30) hervorgerufen wird, auf die Ventile (7) übertragen wird, die somit veranlasst werden, sich allein durch die Hauptnocken (30) zu öffnen,

dadurch gekennzeichnet, dass

die Ventilspielregelvorrichtung eine Buchse (38) umfasst, die in einer Durchgangsöffnung (40) aufgenommen ist, die in einem zentralen Abschnitt des Kipphebels (5) ausgebildet und koaxial zu der ersten Achse (42) ist;

die Buchse (38) eine zentrale Durchgangsöffnung (43) aufweist, die koaxial zu einer zweiten Achse (48) ist, die von der Achse (42) getrennt ist, und welche eine Welle (50), die von dem Motor getragen ist, aufnimmt;

die Buchse (38) in Bezug auf die Welle (50) in einer ersten Winkelanordnung angeordnet sein kann, in der das Ventilspiel den ersten niedrigeren Wert (D1) annimmt; und

die Buchse (38) darüber hinaus in Bezug auf die Welle (50) in einer zweiten Winkelanordnung angeordnet sein kann, in der das Ventilspiel den zweiten höheren Wert (D2) annimmt.

2. System nach Anspruch 1, bei dem Betätigungsmittel (54) vorgesehen sind, die durch ein bewegliches Abtriebsselement bereitgestellt sind, das schwenkbar an einer sich von der Buchse (38) erstreckenden Verlängerung angebracht ist.

Revendications

1. Dispositif de commande de soupapes destiné à un système de recirculation de gaz d'échappement, dans lequel un arbre à cames (3) commande une pluralité de culbuteurs (5) utilisés pour commander des soupapes (7) ; l'arbre à cames (3) portant des lobes principaux (30) utilisés pour déclencher une ouverture totale de soupape aussi bien pour amener l'admission du mélange air/combustible que l'expulsion des gaz d'échappement ; l'arbre à cames portant de plus des lobes auxiliaires

(31) utilisés pour déclencher une ouverture partielle de soupape servant à une fonction de recirculation de gaz d'échappement, le système de commande de soupape comprenant un dispositif de réglage du jeu de soupape adapté pour modifier ledit jeu entre au moins :

une première valeur de jeu faible (D1) dans laquelle le mouvement de basculement du culbuteur (5) produit par le déplacement angulaire des lobes principaux et des lobes auxiliaires est transmis aux soupapes (7) qui sont ainsi amenées à s'ouvrir à la fois par les lobes principaux (30) et par les lobes auxiliaires (31); et une seconde valeur de jeu élevée (D2) dans laquelle seulement le mouvement de basculement du culbuteur (5) produit par le déplacement angulaire des lobes principaux (30) est transmis aux soupapes (7) qui sont ainsi amenées à s'ouvrir par les seuls lobes principaux, **caractérisé en ce que** ledit dispositif de réglage du jeu de soupape comprend un palier (38) logé dans un orifice débouchant (40) formé dans une partie centrale dudit culbuteur (5) et coaxial avec un premier axe (42); ledit palier (38) présentant un orifice débouchant central (43) qui est coaxial avec un second axe (48) lequel est séparé de l'axe (42) et loge un arbre (50) porté par ledit moteur ; étant possible pour ledit palier (38) d'être disposé par rapport audit arbre (50) dans un premier arrangement angulaire dans lequel le jeu de soupape prend ladite première valeur inférieure (D1); étant en outre possible pour ledit palier (38) d'être disposé par rapport audit arbre (50) dans un second arrangement angulaire dans lequel le jeu de soupape prend ladite seconde valeur supérieure (D2).

2. Dispositif selon la revendication 1, dans lequel est fourni un moyen de commande (54) qui est muni d'un élément de sortie déplaçable monté de façon pivotante sur un prolongement qui s'étend à partir dudit palier (38).

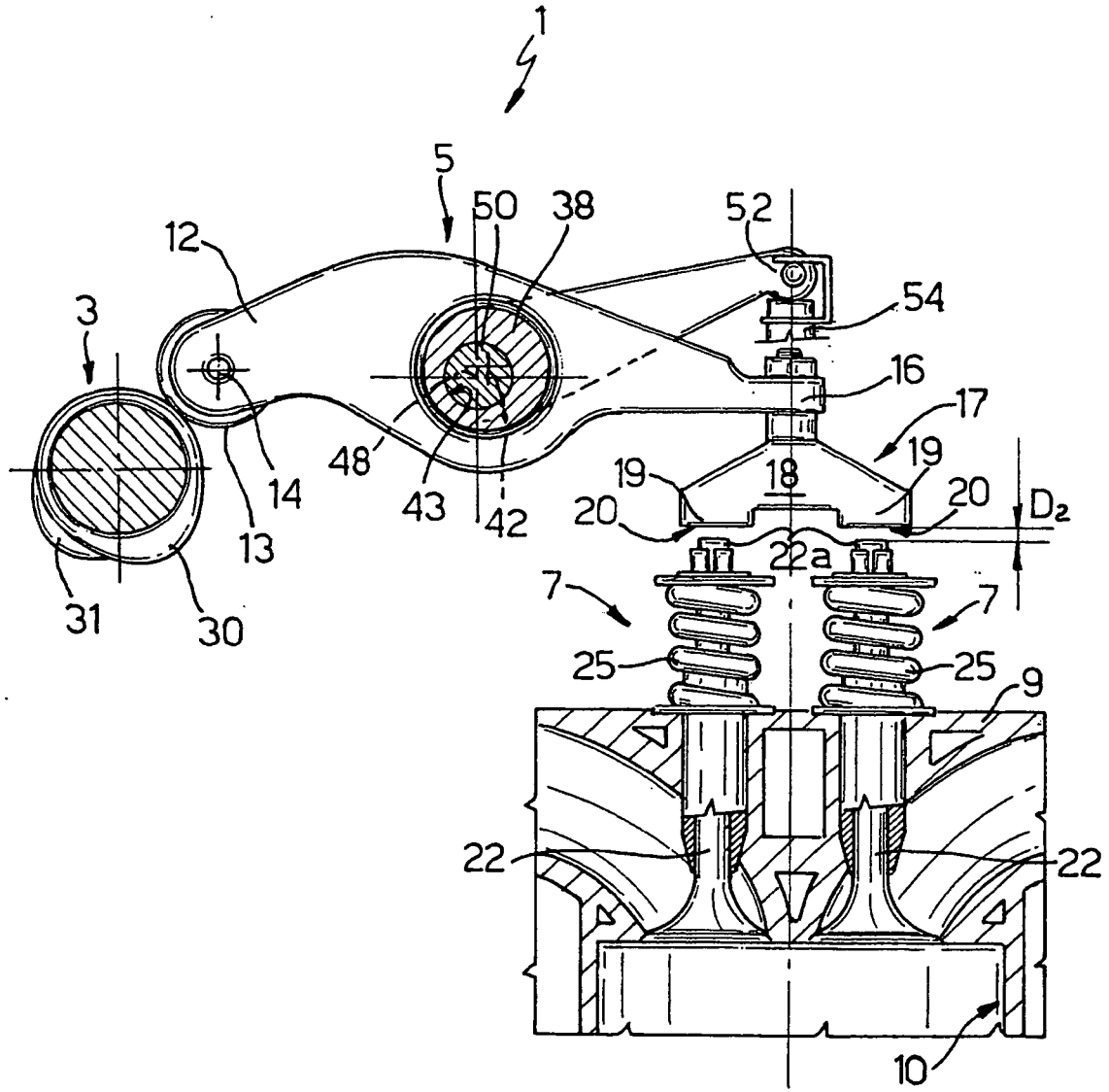

Fig.1

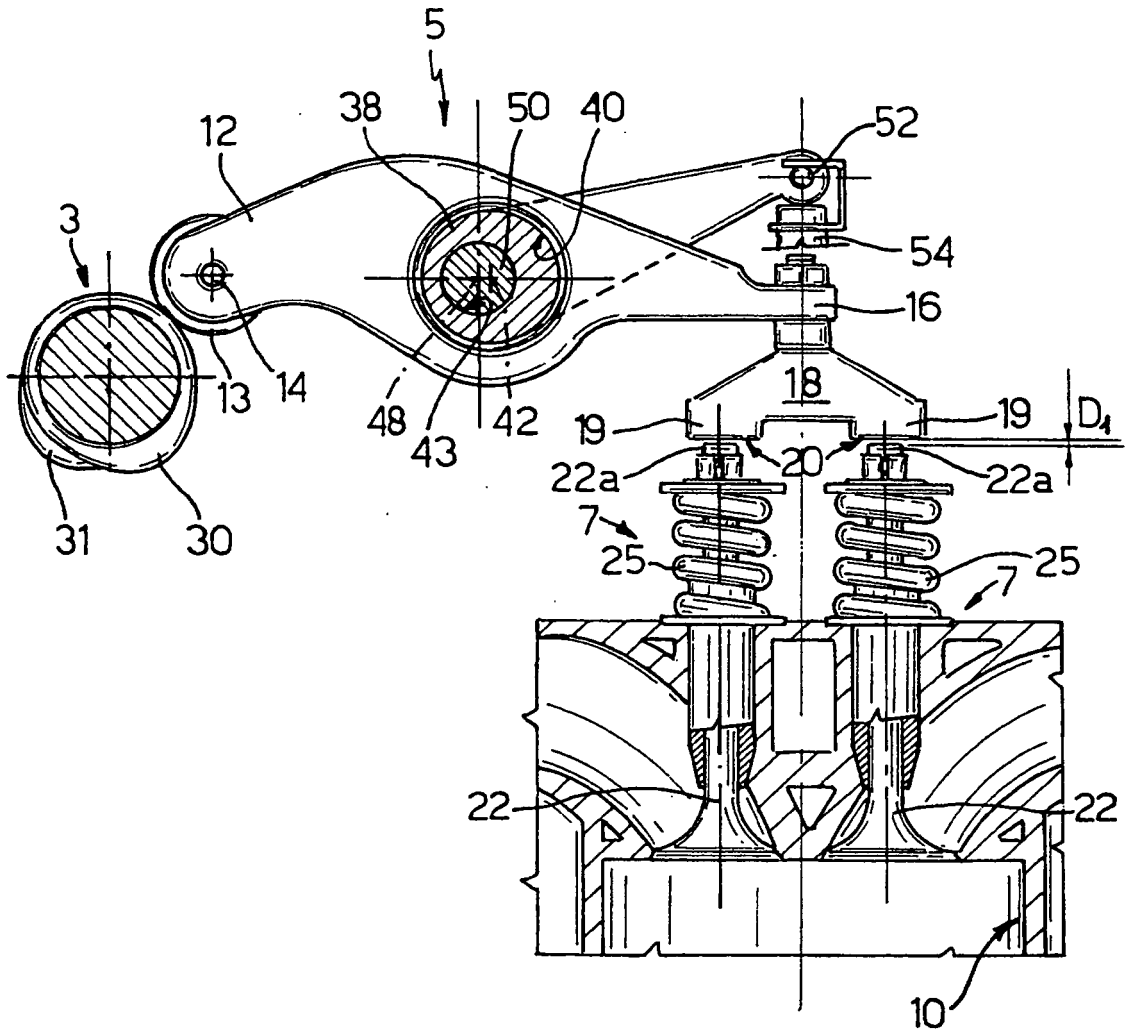

Fig. 2