



(12) **EUROPEAN PATENT APPLICATION**
published in accordance with Art. 158(3) EPC

(43) Date of publication:
02.01.2004 Bulletin 2004/01

(51) Int Cl.7: **B21D 1/14, B60S 5/00**

(21) Application number: **02707139.8**

(86) International application number:
PCT/JP2002/002823

(22) Date of filing: **25.03.2002**

(87) International publication number:
WO 2002/081113 (17.10.2002 Gazette 2002/42)

(84) Designated Contracting States:
**AT BE CH CY DE DK ES FI FR GB GR IE IT LI LU
MC NL PT SE TR**
Designated Extension States:
AL LT LV MK RO SI

(72) Inventor: **NAKANO, Takichi**
Sue-machi, Kasuya-gun, Fukuoka 811-2115 (JP)

(30) Priority: **02.04.2001 JP 2001103808**

(74) Representative: **Turi, Michael, Dipl.-Phys. et al**
Samson & Partner
Widenmayerstrasse 5
80538 München (DE)

(71) Applicant: **Yugen Kaisha Sogo Lease**
Kasuya-gun, Fukuoka 811-2115 (JP)

(54) **BODY FRAME CORRECTOR**

(57) A body frame corrector (1) capable of efficiently correcting a complicatedly deformed frame or the like and providing an excellent workability, comprising a frame-shaped body (2) for installing a deformed body frame (40) therein, a plurality of ceiling cylinders (7),

floor cylinders (10), and side cylinders (9) disposed on the ceiling surface, floor surface, inner side surfaces of the frame shaped body (2) and movable to directions along each of the respective surfaces, and tilting mechanisms for changing the pressing directions of the side surface cylinders (9).

FIG. 10

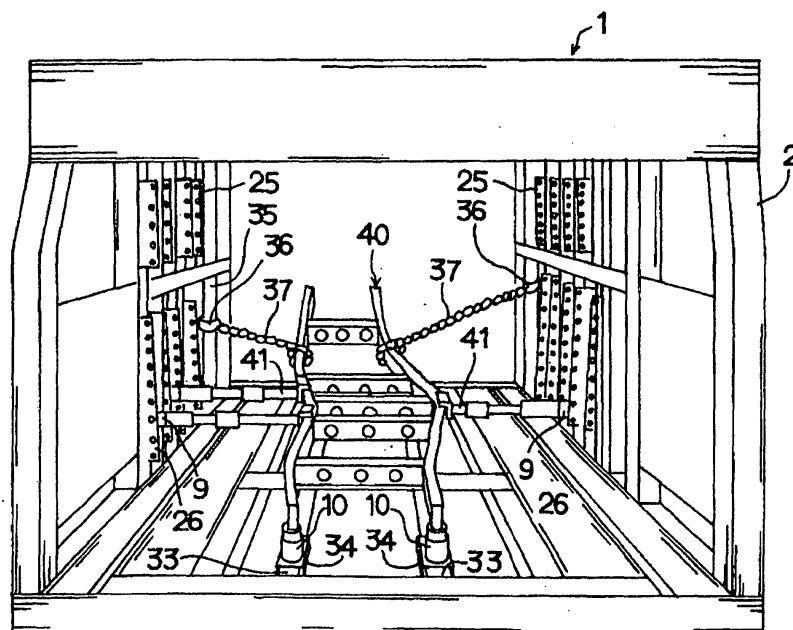

Description**FIELD OF THE INVENTION**

[0001] The present invention relates to a body frame corrector for correcting a frame or a body of an automobile which has been deformed by a traffic accident or the like.

BACKGROUND OF THE INVENTION

[0002] As a device for correcting a frame or a body of an automobile deformed by a traffic accident or the like, some examples of frame correctors are disclosed in Unexamined Japanese Patent Publications Nos. S47-14850, S50-37143, S51-118235, S54-17238 and S55-55221.

[0003] The frame correctors described in the above publications have structures to fix the frames or the bodies using chains or dedicated supporting members. Accordingly, these devices require a large working space as well as considerable labor and time for the operations of fixing the automobiles onto the devices and removing them after correction.

[0004] In addition, when the deformed portions are pressed during the correcting operations, a springback force has to be taken into account, which requires that the operators be highly skilled for accurate correction and, moreover, has sometimes damaged the frames due to an overload or caused unnecessary deformation of undesired portions. Furthermore, the chains pulling the frames or the like may come off or be damaged by an overload, which would lead to serious accidents.

[0005] To solve the above problem, the present inventor has developed a body frame corrector that is capable of correcting a body frame or the like within a short time and in an accurate and safe manner and also realizes an efficient use of a space, which has been disclosed in Unexamined Japanese Patent Publication No. 2000-203395.

[0006] In the body frame corrector disclosed in the above publication, while the pressing devices disposed on the inner side surfaces of the frame-shaped body are movable in the directions along the inner surfaces, the pressing directions are still limited. Therefore, when correcting the frames or the like that have been complicatedly deformed, it tends to be difficult to apply pressure onto the portion to be pressed in an accurate direction, which deteriorates workability.

[0007] In addition, the body frame corrector described above has a limit in moving the pressing devices disposed on the ceiling surface within a front-half portion of the frame-shaped body. Thus, when correcting a long frame or the like, the correcting operations often have to be divided into several steps by moving the frame. This causes the working efficiency to be lowered.

[0008] The present invention relates to an improvement of the above-described body frame corrector,

which provides a body frame corrector capable of efficiently correcting a complicatedly deformed frame or the like with excellent workability.

5 DISCLOSURE OF THE INVENTION

[0009] The body frame corrector of the present invention comprises a frame-shaped body for installing a body frame therein, a plurality of pressing devices for correcting the body frame, said pressing devices being disposed on a ceiling surface, a floor surface and inner side surfaces of the frame-shaped body and movable to directions along each of the respective surfaces, and a tilting mechanism for changing pressing directions of the pressing devices, the tilting mechanism being disposed on the inner side surfaces of the frame-shaped body.

[0010] Employing the above structure, the pressing devices on the inner surfaces of the frame-shaped body can be tilted against the body frame installed within the frame-shaped body when pressing, thereby efficiently correcting even complicatedly deformed frames or the like and enhancing the workability.

[0011] The tilting mechanism described above may comprise a hinge member which moves up and down along a pillar which is mounted on a side of the frame-shaped body and movable in a horizontal direction, a pressing device mounting member provided on the hinge member, and a detachable fixing member to keep the pressing device mounting member in a predetermined posture. By this structure, the pressing device mounted to the pressing device mounting member is movable in both horizontal and vertical directions along the inner side surfaces of the frame-shaped body and can be fixed in a tilted position, which enables the pressing operations in tilted directions to be accurate and safe.

[0012] The above body frame corrector may further comprise a moving mechanism which moves the pressing device disposed on the ceiling surface of the frame-shaped body throughout an entire area of the ceiling surface. Thus, it is possible to press from any position on the ceiling surface to enlarge the operable area, which enhances workability when correcting a comparatively large-sized body frame.

[0013] The above moving mechanism may comprise a rail member disposed on the ceiling surface of the frame-shaped body, a beam member disposed in a direction perpendicular to the rail member and movable along the rail member, and a pressing device mounting member which is movable along the beam member. By this structure, the pressing device can be positioned at any place on the ceiling surface to securely support a reaction force of the pressing device during the pressing operation, which further improves workability and efficiency of the operation.

BRIEF DESCRIPTION OF THE DRAWINGS

[0014]

Fig. 1 is a side view showing a body frame corrector of an embodiment of the present invention;

Fig. 2 is a partially omitted plan view showing the body frame corrector of Fig. 1;

Fig. 3 is a sectional view taken along the line A-A of Fig. 1;

Fig. 4 is a front view of the body frame corrector shown in Fig. 1;

Fig. 5 is a rear view of the body frame corrector shown in Fig. 1;

Fig. 6 is a sectional view taken along the line B-B of Fig. 2;

Fig. 7 is a front view of a side cylinder tilting mechanism shown in Fig. 6;

Fig. 8 is a sectional view taken along the line C-C of Fig. 7;

Fig. 9 is a sectional view taken along the line D-D of Fig. 7;

Fig. 10 is an explanatory perspective view illustrating a correcting operation using the body frame corrector of Fig. 1;

Fig. 11 is an explanatory plan view illustrating a correcting operation using the body frame corrector of Fig. 1;

Fig. 12 is a sectional view taken along the line E-E of Fig. 11,

Fig. 13 is an explanatory plan view illustrating another correcting operation using the body frame corrector of Fig. 1;

Fig. 14 is a sectional view taken along the line F-F of Fig. 13; and

Fig. 15 is an explanatory side view illustrating further another correcting operation using the body frame corrector of Fig. 1.

BEST MODE FOR CARRYING OUT THE INVENTION

[0015] Figs. 1 to 9 show a body frame corrector of an embodiment of the present invention. As shown in Figs. 1 to 5, a body frame corrector 1 of the present embodiment comprises a frame-shaped body 2 formed by a combination of steel materials, frame lifting devices 3 for lifting a body frame installed within the frame-shaped body 2, an operation box 3a of the frame lifting devices 3, wheels 4 and 5 disposed at four positions in front/rear and right/left of the frame-shaped body 2, wheel lifting cylinders 4a and 5a, a steering cylinder 4b for the wheels 4, driving motors 5b for the wheels 5, a plurality of ceiling cylinders 7 and suspending cylinders 8 disposed on a ceiling surface to press the body frame installed within the frame-shaped body 2, a plurality of side cylinders 9 disposed on right and left inner side surfaces, and a plurality of floor cylinders 10 disposed on a floor surface.

[0016] In a front part of the right and left inner side

surfaces of the frame-shaped body 2, reaction force supporting members 12 which are movable up and down by lifting cylinders 11 are disposed. A hydraulic power generator 13, which is disposed for driving the frame lifting devices 3, wheel lifting cylinders 4a and 5a, the steering cylinder 4b, the ceiling cylinders 7, the suspending cylinders 8, the side cylinders 9, the floor cylinders 10 and the lifting cylinders 11, is attachable to and detachable from the frame-shaped body 2. In the present embodiment, all of the cylinders mean hydraulic cylinders as pressing devices.

[0017] On the right and left sides of the ceiling surface, two ceiling rails 14 are disposed in a longitudinal direction. Perpendicular to the ceiling rails 14, four beam members 15 which are movable in front and rear directions along the ceiling rails 14 are disposed. Sliding members 16 are mounted to each of the four beam members 15, which are movable in a longitudinal direction of the beam members 15. Each of the ceiling cylinders 7 and the suspending cylinders 8, mounted to each of the sliding members 16, is movable in front/rear and right/left directions throughout the entire area of the ceiling surface.

[0018] The suspending cylinders 8 are mounted to the sliding members 16 via lifting cylinders 17 having universal joints (not shown) on top and bottom ends thereof. Therefore, the suspending cylinders 8 can freely move in up-and-down, rotating, swinging and tilting directions, which allows the pressing position and direction of the suspending cylinder 8 to be optionally determined. Accordingly, as further explained below, when correcting a deformed body frame, the frame can be pressed at a desired position from an optimal direction depending on size, form and deformed condition of the frame, thereby realizing an accurate correction.

[0019] In a front portion of the ceiling surface of the frame-shaped body 2, disposed are two horizontal rails 18 in a lateral direction and two sliding rails 19 which are perpendicular to and movable along the horizontal rails 18. A sliding member 20 which is movable in a longitudinal direction of the sliding rails 19 is mounted on each bottom surface of the sliding rails 19. The sliding member 20, similar to the sliding member 16, functions as a mounting member of the pressing cylinder or the like.

[0020] The beam members 15, the sliding rails 19, and the sliding members 16 and 20 are freely movable when the ceiling cylinders 7, the suspending cylinders 8 and others are not in use. However, when a reaction force is applied upwardly due to extension of the ceiling cylinders 7, for example, these members are automatically fixed at their present positions with a lock mechanism. Therefore, the members do not move inadvertently during the operation, but become movable again after the upward reaction force is released.

[0021] As shown in Fig. 3, a horizontal supporting member 21 is detachably mounted on the floor surface of the frame-shaped body 2 to be movable along the

floor surface. Also on the upper surface of the horizontal supporting member 21, auxiliary cylinders 10a, which have a similar function as the floor cylinders 10, are mounted, which allows the same supporting and pressing operations as the floor cylinders 10. The auxiliary cylinders 10a, which are movable in a longitudinal direction of the horizontal supporting member 21, also enable supporting and pressing operations out of the moving range of the floor cylinders 10.

[0022] The side cylinders 9, as shown in Fig. 6, are mounted to be movable up and down along a pillar 22 made of H-shaped steel, which is movable in a horizontal direction. Four of the pillars 22 are each provided on both right and left side surfaces of the frame-shaped body 2. The pillar 22 is disposed between two side rails 29 arranged at different heights and side members 30. To allow a smooth movement of the pillar 22 in a horizontal direction, casters 31 rotating along top surfaces of the side rails 29 are provided on outer side surface of the pillar 22.

[0023] As shown in Figs. 7 to 9, a hinge member 23 is mounted to the pillar 22 to be movable up and down in a longitudinal direction. A pair of supporting plates 25 and 26 are fixed to the pillar 22 at two positions with different heights in a manner that the supporting plates 25 and 26 sandwich the pillar 22. On a surface facing each other of each of the supporting plates 25 and 26, a guide rail 32 is disposed, and sliding member 23s fixed to an upper plate 23a of the hinge member 23 is slidably engaged with a gap between the pillar 22 and the guide rail 32. To a lower plate 23b of the hinge member 23 which can be tilted toward a center of the frame-shaped body 2, a cylinder mounting member 24 is fixed.

[0024] By inserting a fixing pin 28 into one of a plurality of fixing holes 27 mounted to the supporting plates 25 and 26 to support a lower surface of the cylinder mounting member 24, as shown in Fig. 6, the cylinder mounting member 24 can be kept in a horizontal or tilted posture. Thus, a pressing direction of the side cylinder 9 which is mounted coaxially with the cylinder mounting member 24 can be determined in a horizontal or tilted posture.

[0025] The floor cylinders 10 are, as shown in Figs. 3 to 5, disposed on the floor surface of the frame-shaped body 2, and mounted to six floor rails 33 which are movable in right and left directions along the floor surface via sliding members 34, respectively, which allows the floor cylinders 10 to be movable in front/rear and right/left directions on the floor surface. Furthermore, the floor cylinders 10, which are fixed to the sliding members 34 by engaging an internal screw portion formed on each lower end of the floor cylinders 10 with an external screw portion formed in each of the sliding members 34, can be detachable from the sliding members 34. Thus, only the floor cylinders 10 can be replaced. The floor rails 33 and the sliding members 34 are freely movable when the floor cylinders 10 are not in use. However, when a reaction force is applied downwardly due to extension

of the floor cylinders 10, for example, these members are automatically fixed at their present positions with a lock mechanism. Therefore, the members do not move inadvertently during the operation, but become movable again after the downward reaction force is released.

[0026] As shown in Fig. 1, as auxiliary members for fixing a chain 37 explained below, a plurality of fixing members 36 are mounted to pillars 35 standing on the side surface of the frame-shaped body 2. The fixing members 36 are movable up and down along the pillars 35 and can be fixed to any position on the pillars 35 using a fixing screw 42.

[0027] As shown in Figs. 1 and 5, on supporting posts 38 disposed at both right and left ends of the rear side of the frame-shaped body 2, a plurality of engaging holes 38a are formed at various heights, one of which is chosen to detachably mount a horizontal bar 39 made of H-shaped steel. To the horizontal bar 39, mounted are a plurality of fixing members 46 for fixing the chain 37, which are movable in a longitudinal direction of the horizontal bar 39. The horizontal bar 39 and the fixing members 46 function, similarly to the above-described pillars 35 and the fixing members 36, as fixing means for the chain 37.

[0028] The members such as the ceiling cylinders 7, the suspending cylinders 8, and the side cylinders 9 and the floor cylinders 10 are provided with oil cylinders inside which are operated by a hydraulic power generator 13 and screw portions at their tip ends to which various forms of engaging attachments that fit different portions of a body frame to be corrected can be mounted.

[0029] The lifting cylinders 17 to lift up and put down the suspending cylinders 8 and the lifting cylinders 11 to lift up and put down the reaction force supporting members 12, which are also oil cylinders operated by the hydraulic power generator 13, have a larger moving stroke compared to the oil cylinders operating the ceiling cylinders 7 and other members and thus can lift up and put down the suspending cylinders 8 and the reaction force supporting members 12 in a wider range. The body frame corrector 1 can be operated by an operation box 13a of the hydraulic power generator 13.

[0030] Next, referring to Figs. 10 to 12, a correcting operation using the body frame corrector 1 will be explained below. As shown in Fig. 10, a body frame 40 which has been deformed by a traffic accident or the like is inserted into the frame-shaped body 2 from the front side or the rear side thereof. A front portion of the body frame 40 is laid on the floor cylinders 10 while right and left sides of the rear portion are supported by the chains 37 which are fixed by the fixing members 36. Then, tip ends of engaging attachments 41 mounted to three of the side cylinders 9 projecting from the inner side surface are put on the deformed portion of the body frame 40. Thus, the body frame 40, the floor cylinders 10, the side cylinders 9, the chains 37 and other members are arranged in the state shown in Figs. 11 and 12.

[0031] In the above arrangement, the three side cyl-

inders 9 are correlatively operated to gradually press the deformed portion of the frame body 40 at three points and elastically transform the deformed portion, thereby restoring the original form of the body frame 40 which has been deformed. After completing the correction of the body frame 40, the side cylinders 9, the chains 37 and others are removed to take out the body frame 40 from the frame-shaped body 2.

[0032] According to the correcting operation using the body frame corrector 1, three different points on the body frame 40 are simultaneously pressed to constantly apply a pressure in a stable condition without rattling or shaking during the correcting operation, thereby completing the operation with high accuracy in a short period of time. Furthermore, as a deformed portion of the body frame 40 along with the proximity of the portion are directly pressed to be corrected, the spring back force is extremely small, which enables an operator without an advanced skill to conduct accurate correction. In addition, all of the correcting operations can be carried out within the frame-shaped body 2, prompting more effective use of the working space.

[0033] The floor cylinders 10, the side cylinders 9, the fixing members 36 of the chains 37 and others, which are independently movable, can be disposed at optimal positions according to the size of the body frame 40 and the deformed condition, making the correcting operation more appropriate. The pressing position and direction of the side cylinders 9 are alterable by inserting the fixing pin 28 into one selected from the plurality of the fixing holes 27 of the supporting plates 25 and 26. Thus, the body frame 40 complicatedly deformed, which needs to be pressed from the slanting directions, can also be corrected with accuracy, which leads to excellent workability and an efficient operation.

[0034] Next, referring to Figs. 13 to 15, another correcting operation using the body frame corrector 1 will be explained below. When correcting a body frame 43 which has been complicatedly deformed over a relatively wide range, the suspending cylinders 8, in addition to the side cylinders 9, are used for the correcting operation. As shown in Fig. 13, depending on the deformed condition of the body frame 43, the side cylinders 9 and the suspending cylinders 8 are moved to suitable positions respectively, to which the engaging attachments 41 and others are mounted, and the distal ends thereof are put on the deformed portion and their proximity of the body frame 43. Here, base end portions of the suspending cylinders 8 are made to touch the reacting force supporting members 12 in order to support the reaction force of the suspending cylinders 17 which are disposed at the up front position.

[0035] Keeping the above arrangement, the deformed portion and others are gradually pressed by operating the side cylinders 9 and the suspending cylinders 8 to restore the original form of the body frame 43. Also in this case, rather than operating all of the side cylinders 9 and the suspending cylinders 8 at the same

time, it is preferable that each single step to press three different points of the body frame 43 is conducted in turn. If there is concern that the body frame 43 might be deformed inwardly by pressure, such deformation can be prevented by disposing one of the suspending cylinders 8 inside the body frame 43 to support the body frame 43 from the inside using an extension attachment 44 having an appropriate length.

[0036] Referring to Fig. 15, further another correcting operation using the body frame corrector 1 will be explained below. When correcting a body frame 45 which has been deformed in a vertical direction, the body frame 45 installed within the frame-shaped body 2 is placed on the floor cylinders 10 with the deformed portion positioned between two of the floor cylinders 10. The deformed portion is pressed with the ceiling cylinder 7 to restore the original form. Also in this operation, as three different points of the body frame are simultaneously pressed, without rattling nor shaking during the correcting operation, the pressure can be applied in a constantly stable state, leading to an accurate and safe correcting operation completed in a short period of time.

[0037] In the body frame corrector in the above embodiment, the hydraulic power generator 13, which is attachable to and detachable from the frame-shaped body 2, can be separated from the frame-shaped body 2 and used in combination with other pressing devices having oil cylinder systems.

[0038] The whole body of the body frame corrector 1 can be driven in any desired directions by moving the wheels 4 and 5 down onto the ground using the wheel lifting cylinders 4a and 5a and spacing the frame-shaped body 2 from the ground, followed by rotating the wheels 5 with the driving motors 5b and steering the wheels 4 with the steering cylinder 4b. Accordingly, it is easy to transfer the body frame corrector 1 to a working site, to carry it in a workshop, to install a body frame within the frame-shaped body 2, and to return the body frame corrector 1 to a storehouse after an operation. After stopping the body frame corrector 1, by lifting the wheels 4 and 5 using the wheel lifting cylinders 4a and 5a, the frame-shaped body 2 is landed on the ground and the wheels 4 and 5 are stored inside the frame-shaped body 2.

INDUSTRIAL APPLICABILITY

[0039] The body frame corrector according to the present invention is suitable for correcting a frame or a body of an automobile complicatedly deformed by a traffic accident or the like by directly applying a pressure onto the frame or the body.

Claims

1. A body frame corrector comprising:

a frame-shaped body for installing a body frame therein,
 a plurality of pressing devices for correcting the body frame, said pressing devices being disposed on a ceiling surface, a floor surface and inner side surfaces of the frame-shaped body and movable to directions along each of the respective surfaces, and
 a tilting mechanism for changing pressing directions of the pressing devices, said tilting mechanism being disposed on the inner side surfaces of the frame-shaped body.

2. The body frame corrector according to claim 1, wherein the tilting mechanism comprises:

a hinge member which moves up and down along a pillar which is mounted on a side of the frame-shaped body and movable in a horizontal direction,
 a pressing device mounting member provided on the hinge member, and
 a detachable fixing member to keep the pressing device mounting member in a predetermined posture.

3. The body frame corrector according to claim 1 further comprising a moving mechanism which moves the pressing device disposed on the ceiling surface of the frame-shaped body throughout an entire area of the ceiling surface.

4. The body frame corrector according to claim 3, wherein said moving mechanism comprises:

a rail member disposed on the ceiling surface of the frame-shaped body,
 a beam member disposed in a direction perpendicular to the rail member and movable along the rail member, and
 a pressing device mounting member which is movable along the beam member.

45

50

55

FIG. 1

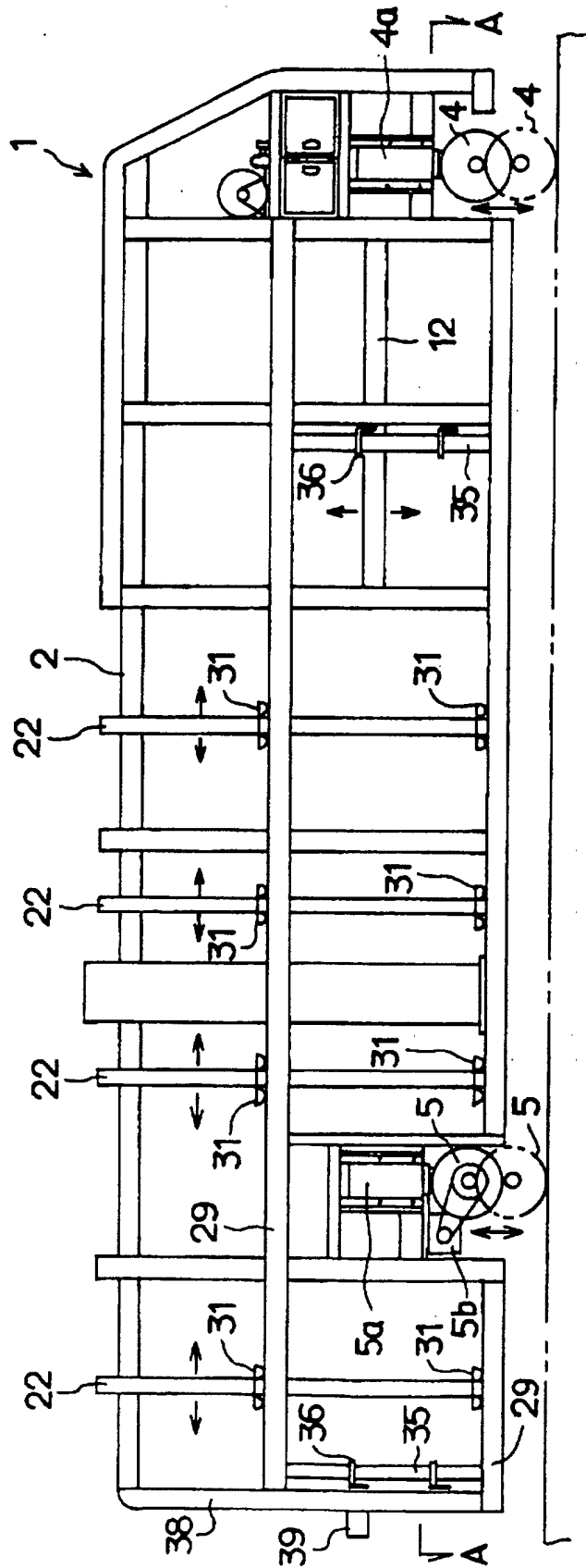

FIG. 3

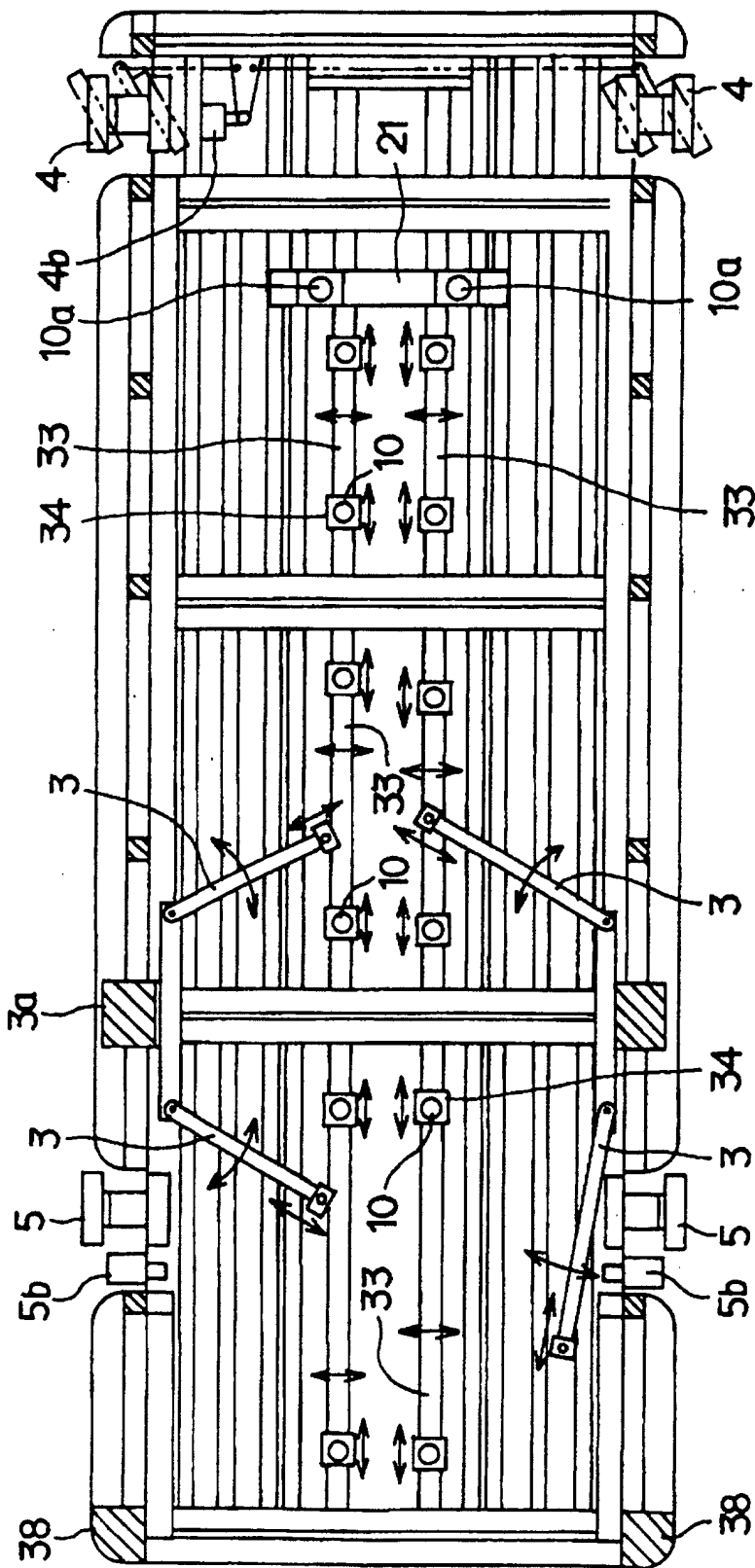

FIG. 4

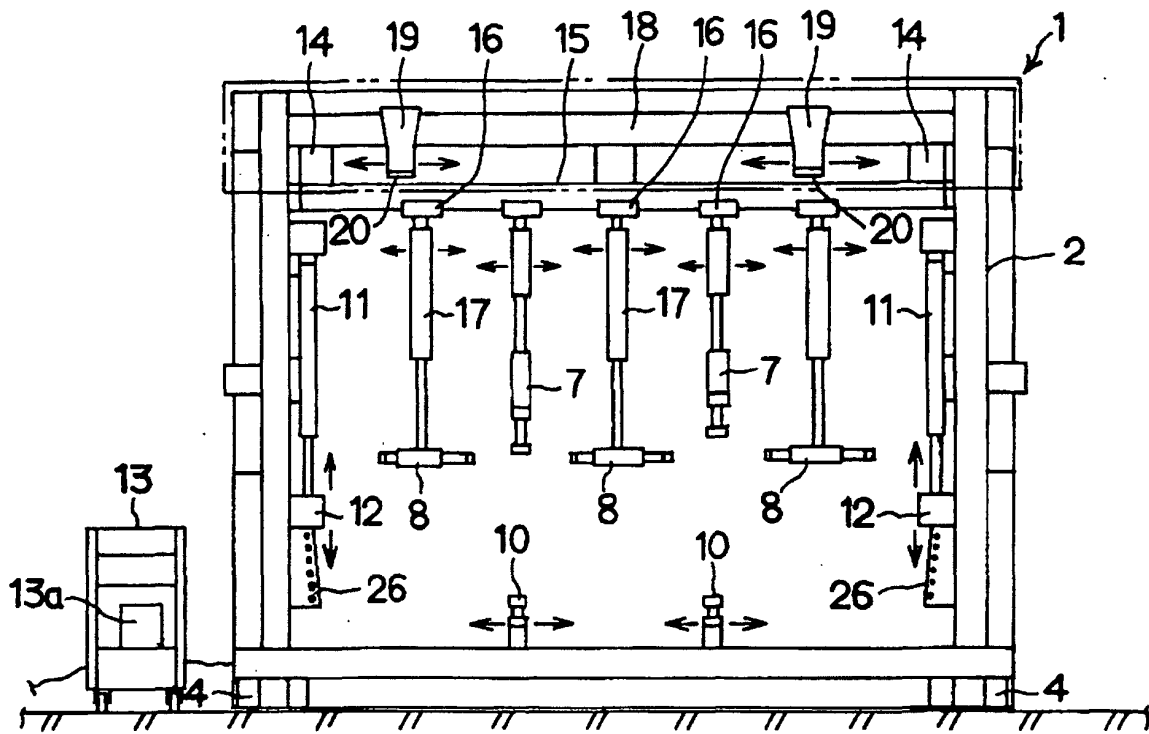

FIG. 5

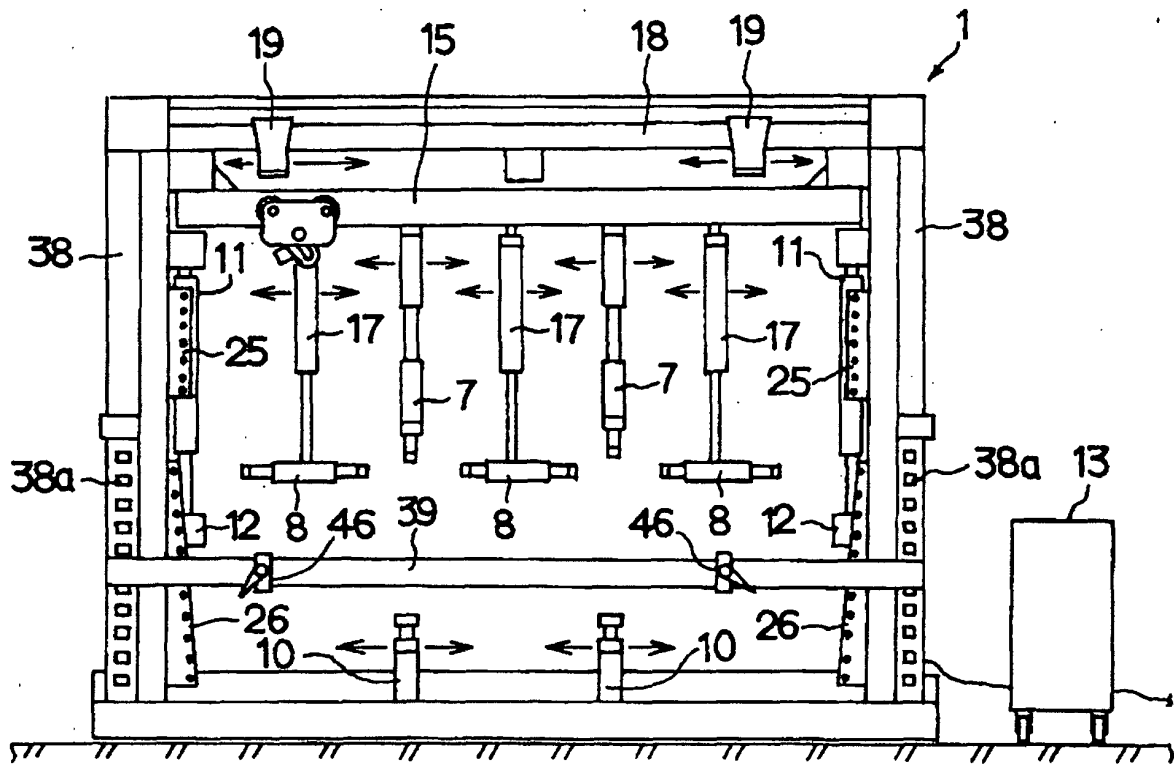

FIG. 6

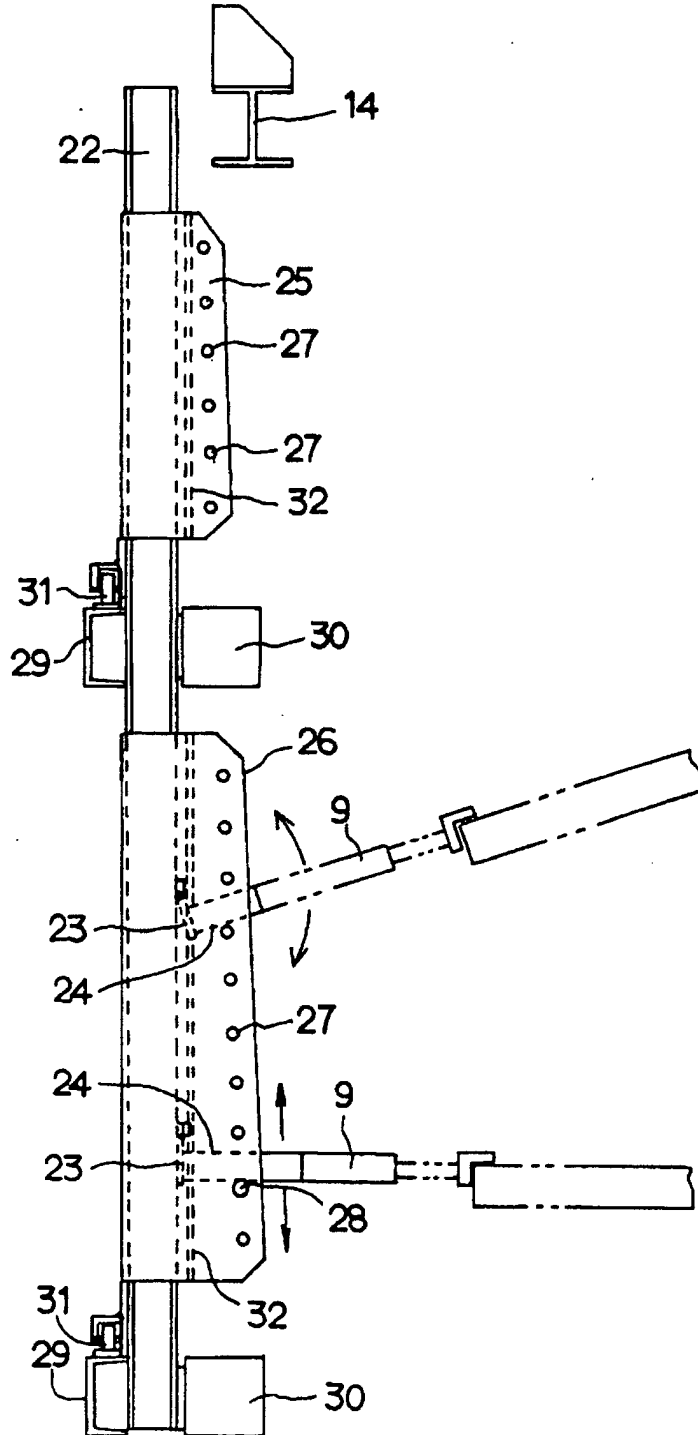

FIG. 7

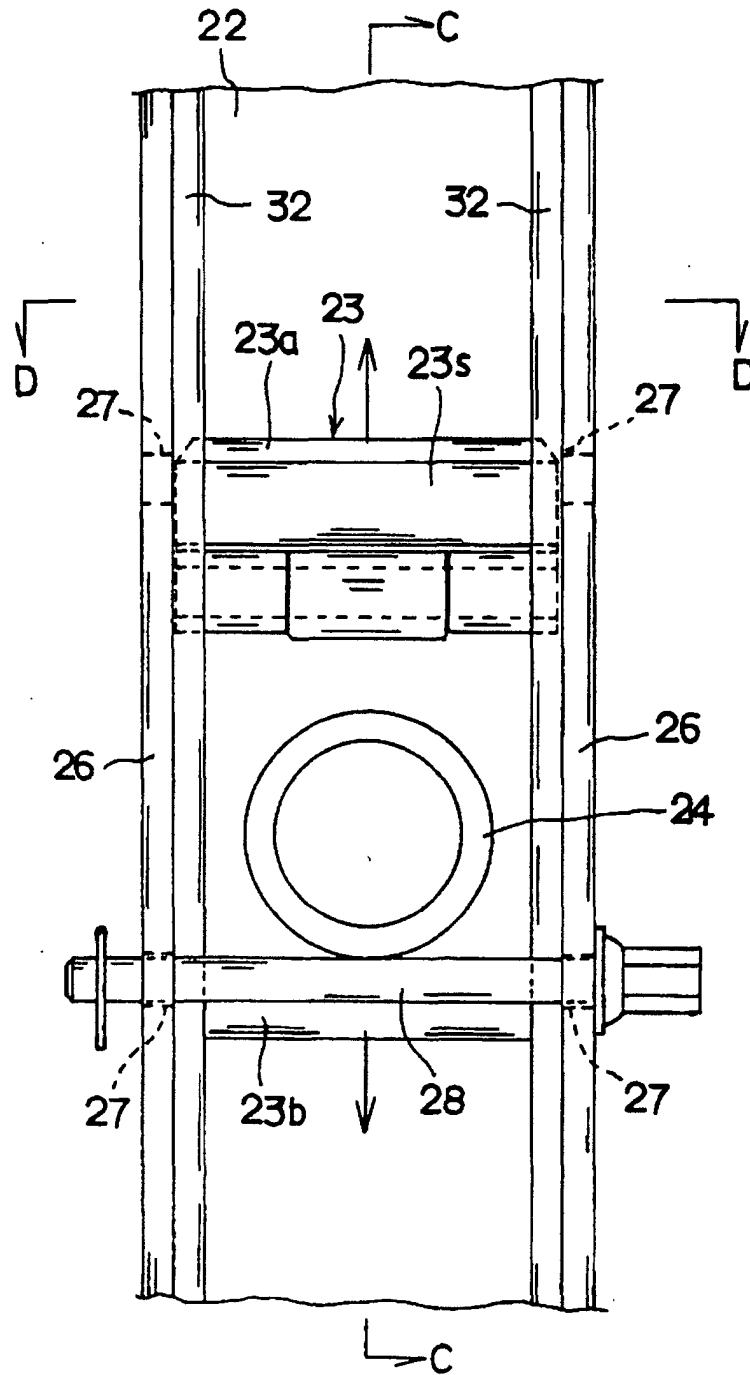

FIG. 8

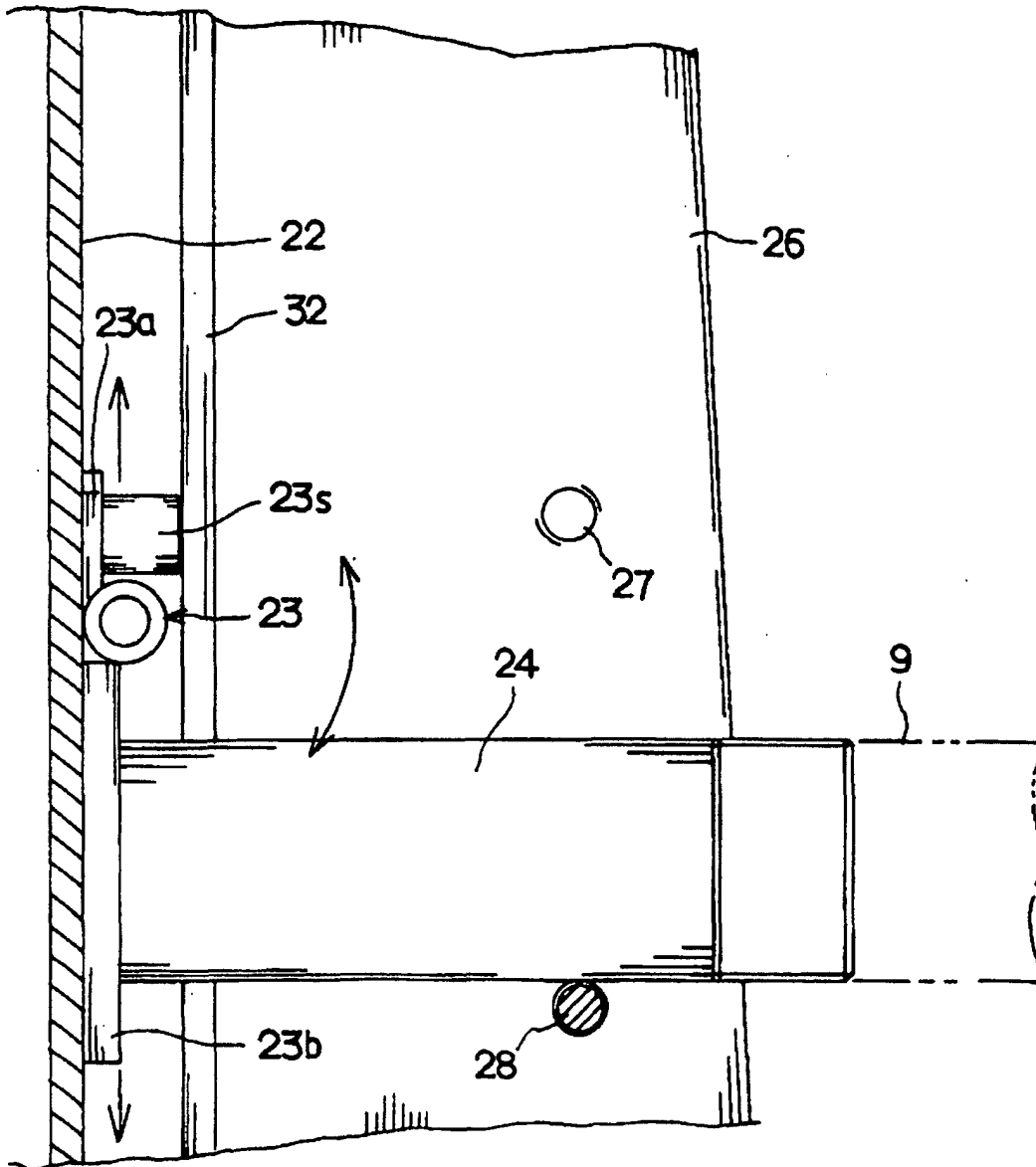

FIG. 9

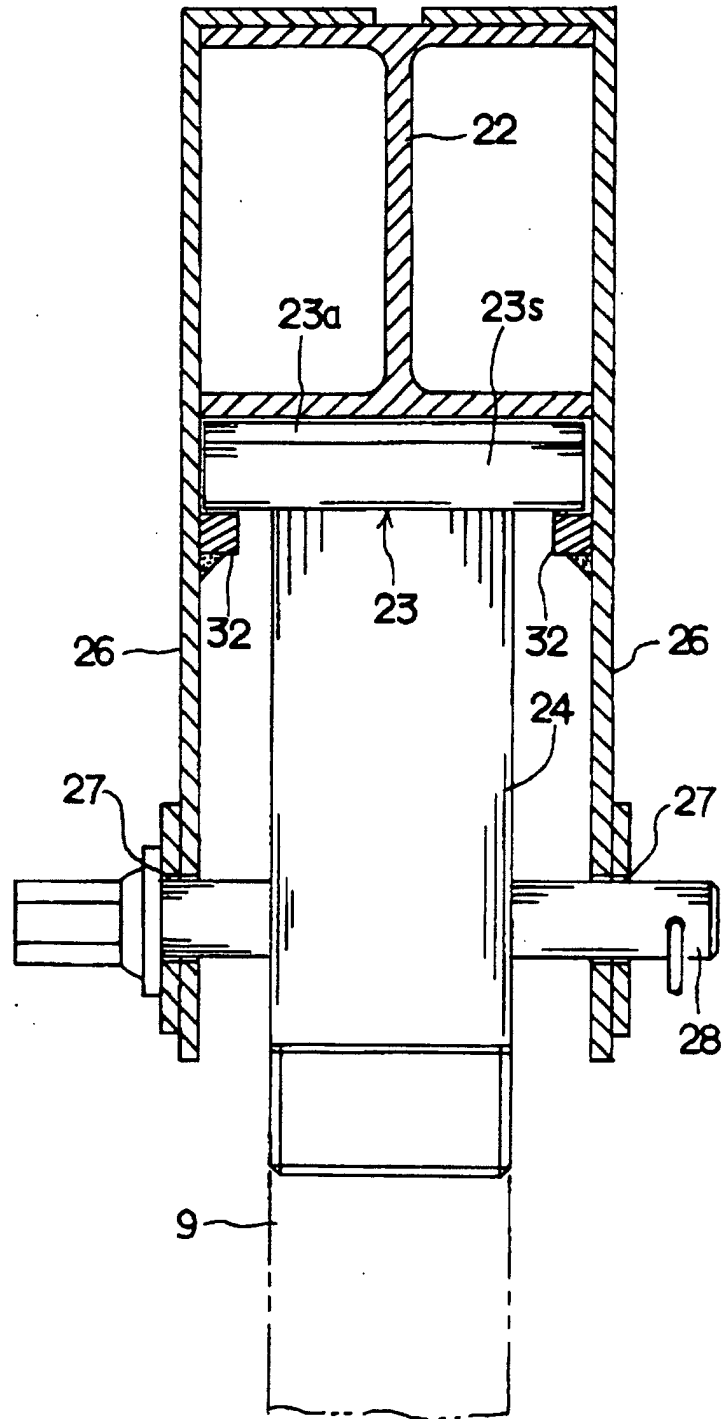

FIG. 10

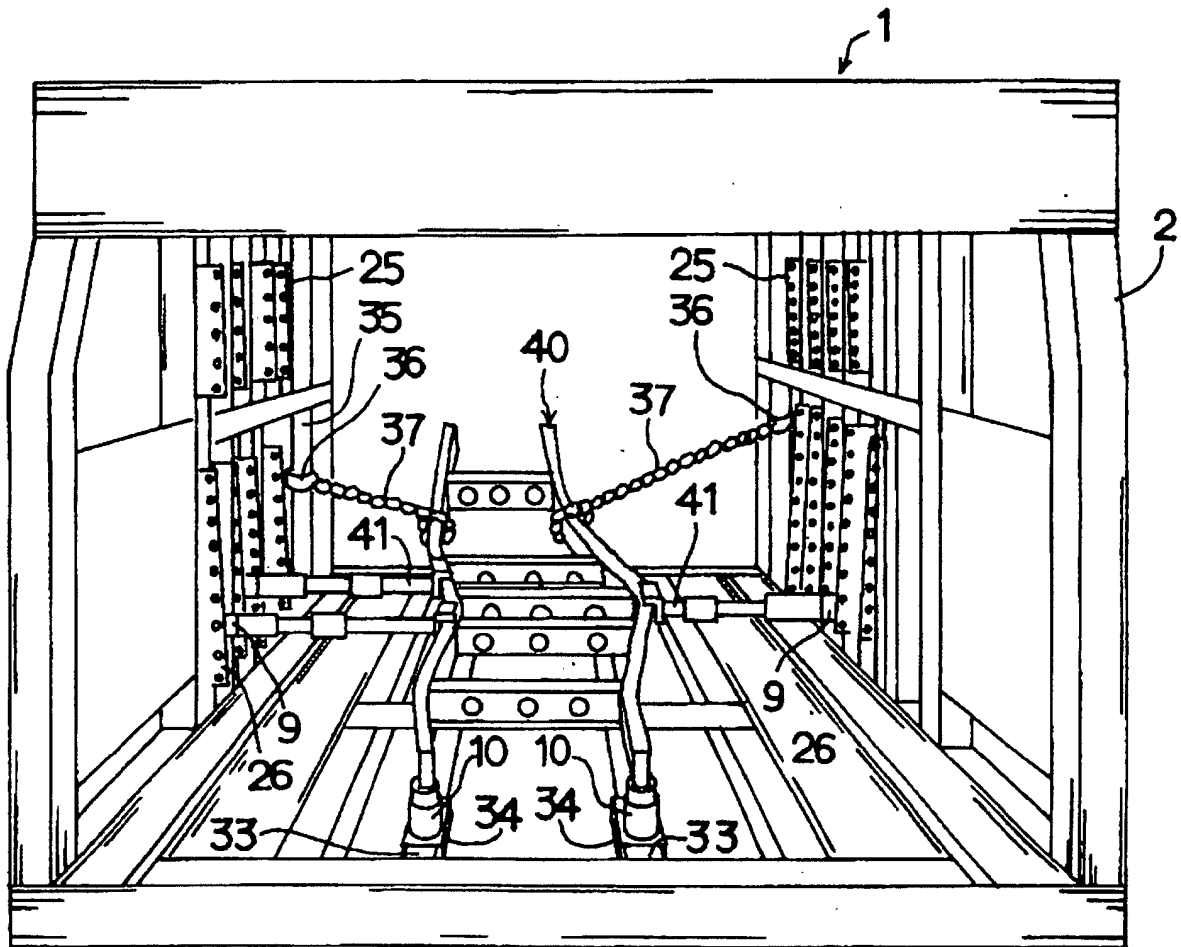

FIG. 12

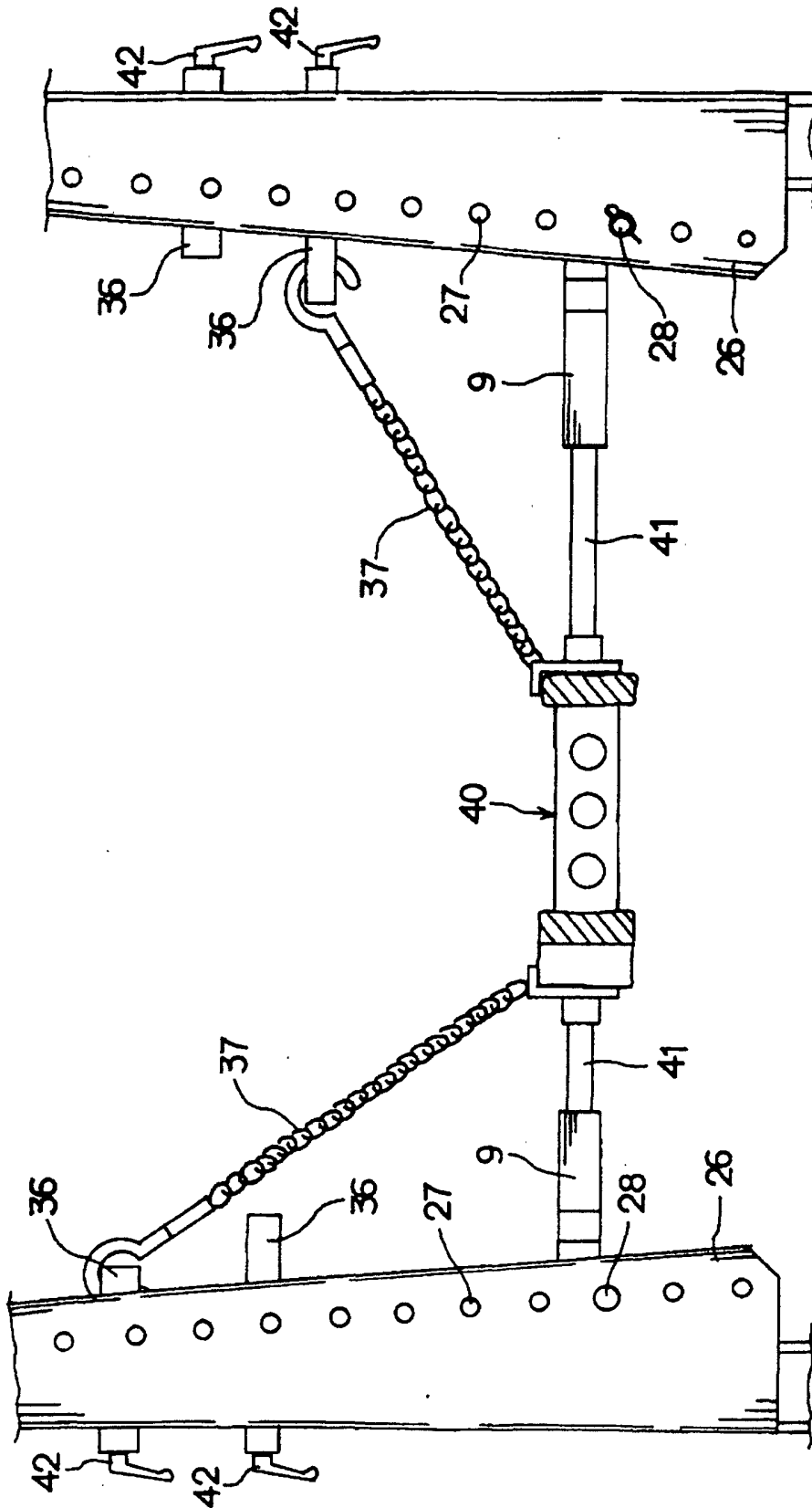

FIG. 13

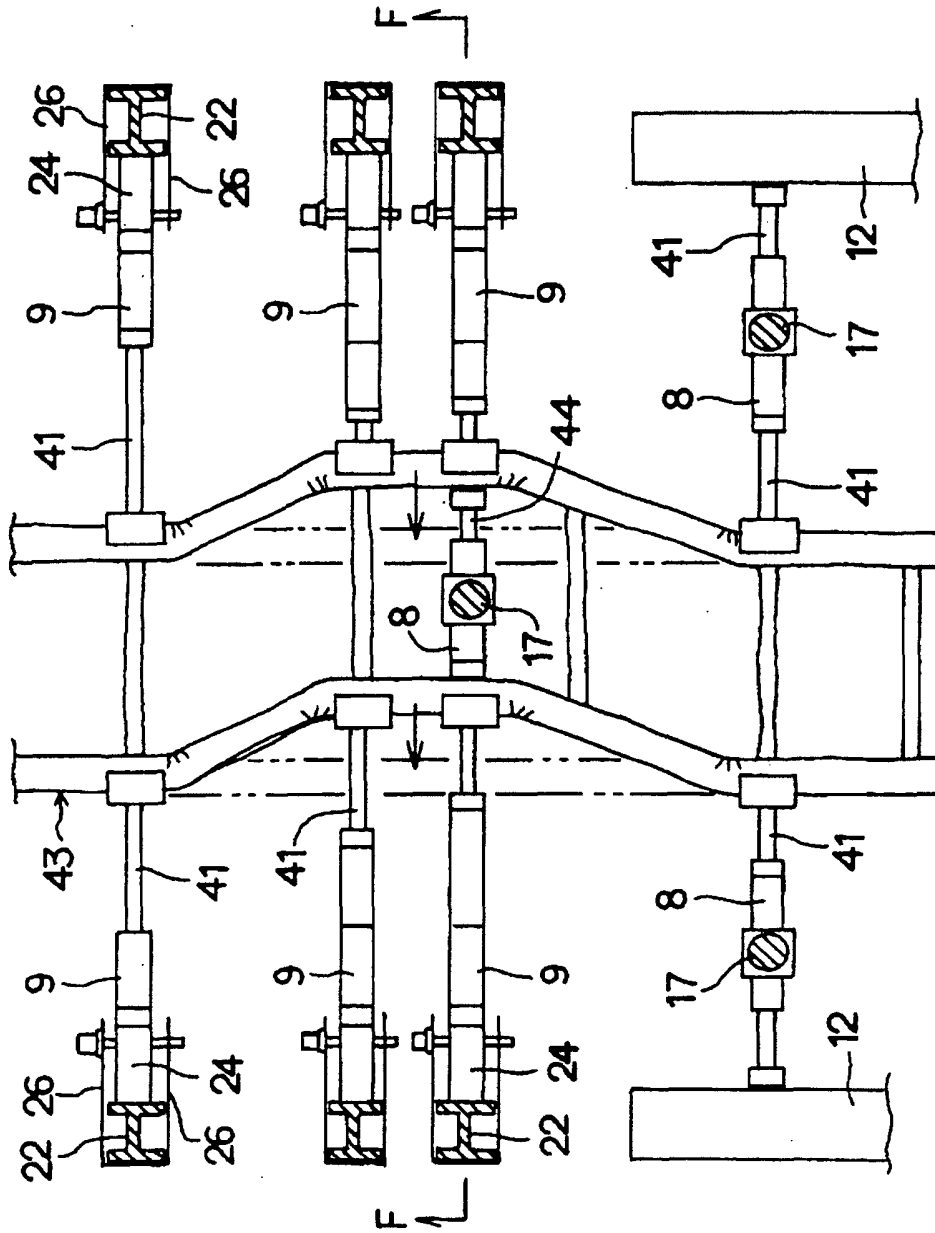

FIG. 14

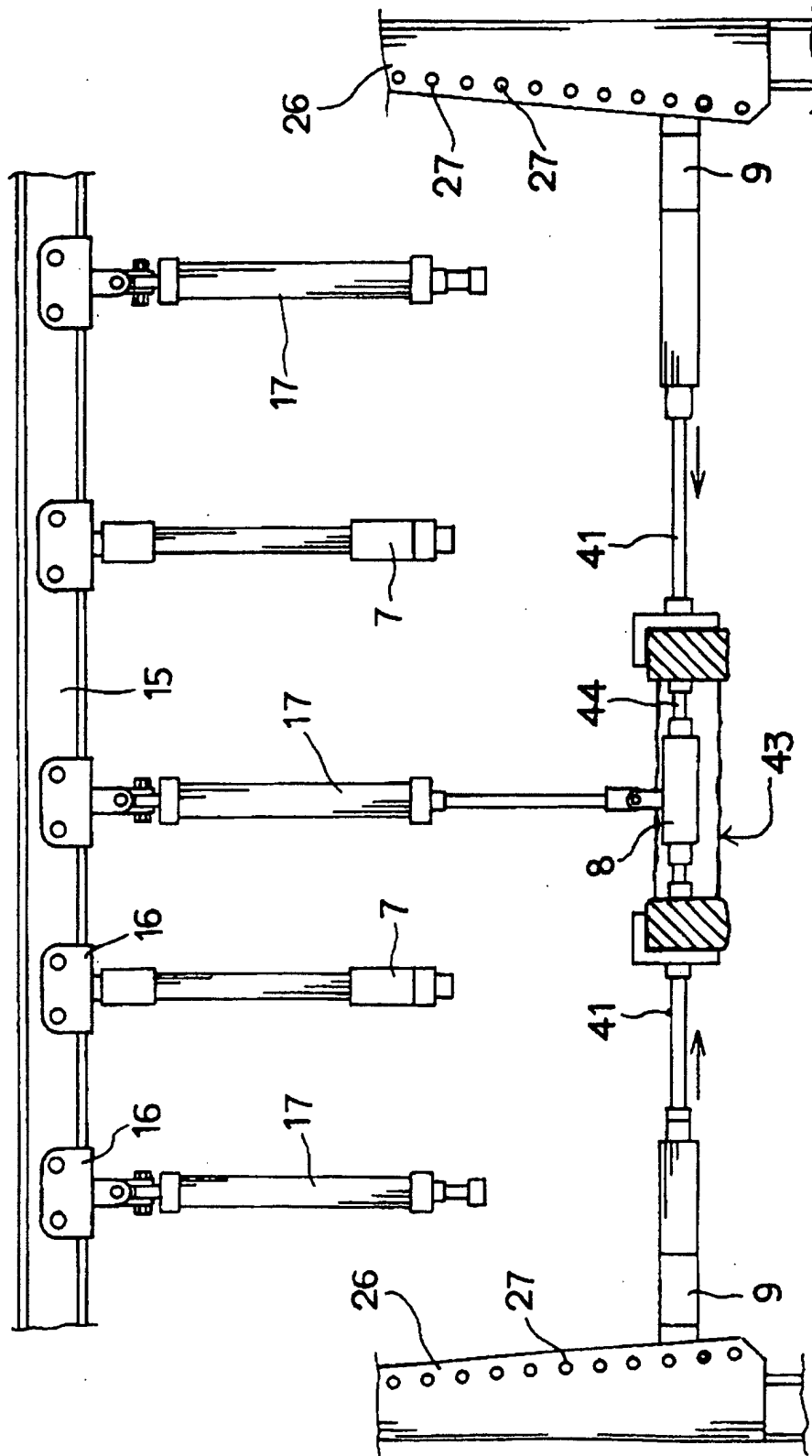
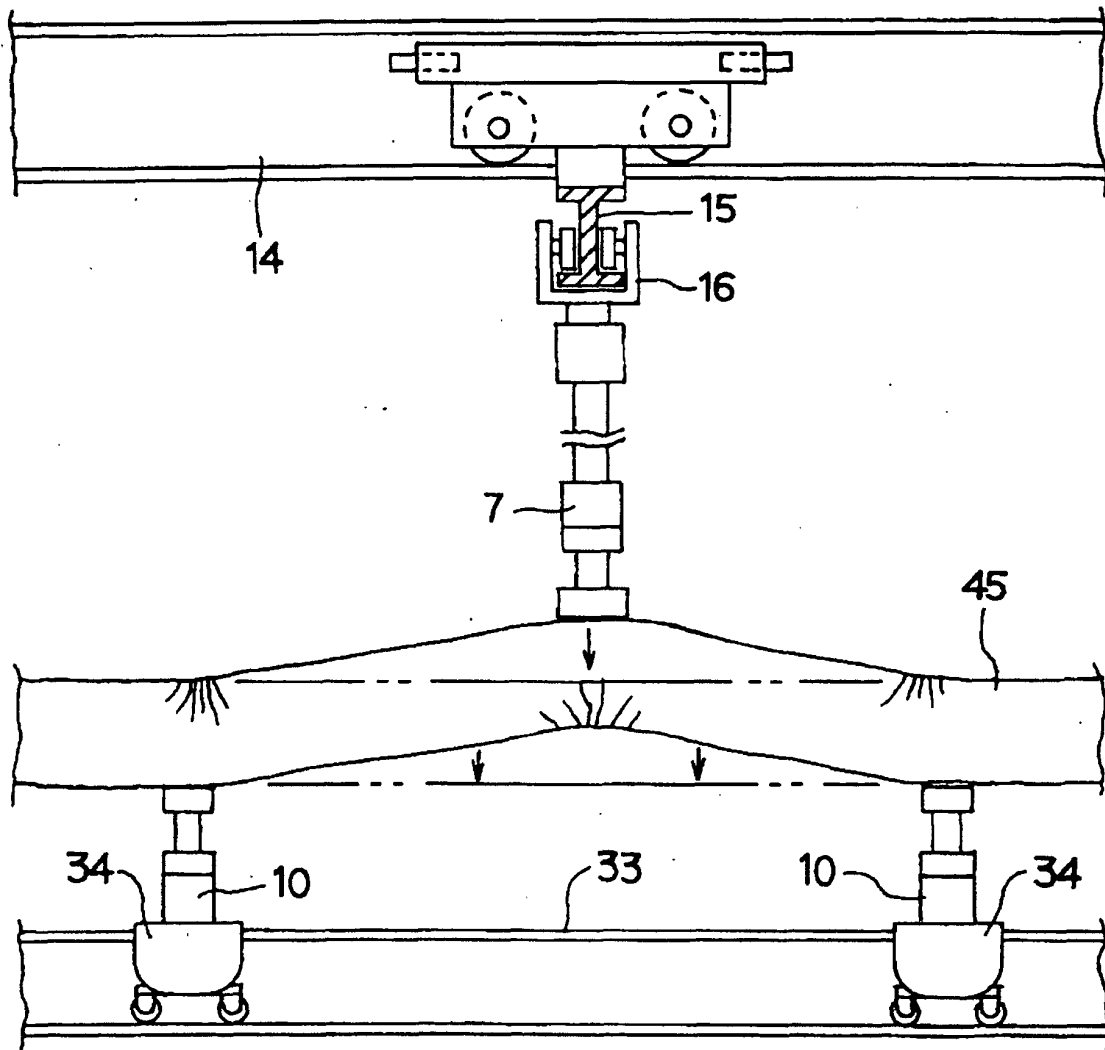

FIG. 15



INTERNATIONAL SEARCH REPORT

International application No.

PCT/JP02/02823

A. CLASSIFICATION OF SUBJECT MATTER Int.Cl ⁷ B21D1/14, B60S5/00		
According to International Patent Classification (IPC) or to both national classification and IPC		
B. FIELDS SEARCHED		
Minimum documentation searched (classification system followed by classification symbols) Int.Cl ⁷ B21D1/12, B21D1/14, B60S5/00		
Documentation searched other than minimum documentation to the extent that such documents are included in the fields searched Jitsuyo Shinan Koho 1922-1996 Jitsuyo Shinan Toroku Koho 1996-2002 Kokai Jitsuyo Shinan Koho 1971-2002 Toroku Jitsuyo Shinan Koho 1994-2002		
Electronic data base consulted during the international search (name of data base and, where practicable, search terms used)		
C. DOCUMENTS CONSIDERED TO BE RELEVANT		
Category*	Citation of document, with indication, where appropriate, of the relevant passages	Relevant to claim No.
Y	JP 2000-203395 A (Takichi NAKANO), 25 July, 2000 (25.07.00), Full text; Figs. 1 to 21 (Family: none)	1-4
A	US 4700559 A (Byron A. Larson), 20 October, 1987 (20.10.87), Full text; Figs. 1 to 9 (Family: none)	1-4
A	JP 11-170988 A (Warudo Kurasu Supiritto Yugen Kaisha), 29 June, 1999 (29.06.99), Full text; Figs. 1 to 15 (Family: none)	1-4
<input checked="" type="checkbox"/> Further documents are listed in the continuation of Box C. <input type="checkbox"/> See patent family annex.		
* Special categories of cited documents: "A" document defining the general state of the art which is not considered to be of particular relevance "E" earlier document but published on or after the international filing date "L" document which may throw doubts on priority claim(s) or which is cited to establish the publication date of another citation or other special reason (as specified) "O" document referring to an oral disclosure, use, exhibition or other means "P" document published prior to the international filing date but later than the priority date claimed "T" later document published after the international filing date or priority date and not in conflict with the application but cited to understand the principle or theory underlying the invention "X" document of particular relevance; the claimed invention cannot be considered novel or cannot be considered to involve an inventive step when the document is taken alone "Y" document of particular relevance; the claimed invention cannot be considered to involve an inventive step when the document is combined with one or more other such documents, such combination being obvious to a person skilled in the art "&" document member of the same patent family		
Date of the actual completion of the international search 18 June, 2002 (18.06.02)		Date of mailing of the international search report 02 July, 2002 (02.07.02)
Name and mailing address of the ISA/ Japanese Patent Office		Authorized officer
Facsimile No.		Telephone No.

Form PCT/ISA/210 (second sheet) (July 1998)

INTERNATIONAL SEARCH REPORT

International application No.

PCT/JP02/02823

C (Continuation). DOCUMENTS CONSIDERED TO BE RELEVANT		
Category*	Citation of document, with indication, where appropriate, of the relevant passages	Relevant to claim No.
A	JP 53-47642 A (Toibo·Orabi·Benereinen), 28 April, 1978 (28.04.78), Full text; Figs. 1 to 11 (Family: none)	1-4
A	DE 4409623 A (Autorobot Finland KY), 03 November, 1994 (03.11.94), Full text; Figs. 1 to 5 & FI 931296 A & US 5730019 A & JP 6-328322 A	2

Form PCT/ISA/210 (continuation of second sheet) (July 1998)