



(12) **EUROPEAN PATENT APPLICATION**

(43) Date of publication:
25.02.2004 Bulletin 2004/09

(51) Int Cl.7: **B65H 75/36**

(21) Application number: **03255044.4**

(22) Date of filing: **14.08.2003**

(84) Designated Contracting States:
**AT BE BG CH CY CZ DE DK EE ES FI FR GB GR
HU IE IT LI LU MC NL PT RO SE SI SK TR**
Designated Extension States:
AL LT LV MK

(72) Inventor: **Hartranft, Bruce W.**
St Charles, Illinois 60175 (US)

(74) Representative: **Spencer, Michael David, Dr. et al**
Bromhead & Co.,
37 Great James Street
London WC1N 3HB (GB)

(30) Priority: **23.08.2002 US 226839**

(71) Applicant: **Ideal Industries Inc.**
Sycamore, IL 60178 (US)

(54) **Translucent fish tape housing**

(57) A translucent fish tape housing is disclosed. The translucent nature of the housing allows a user to observe the type, amount and condition of the tape within the housing without having to remove the tape.

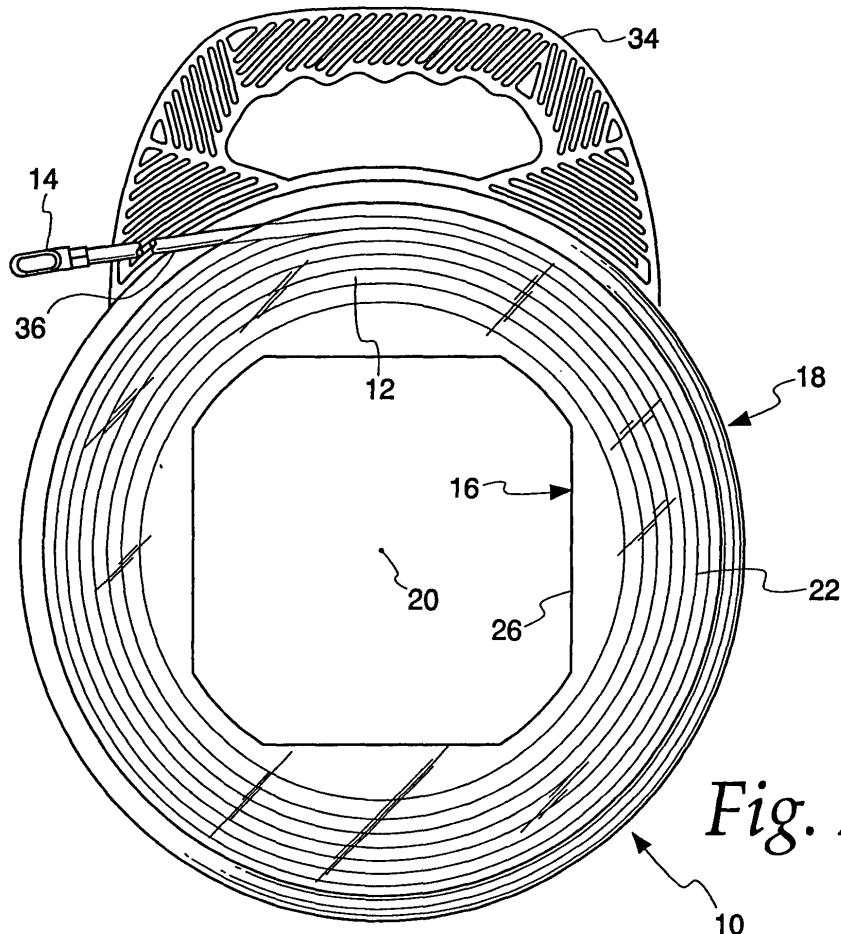

Fig. 2

Description

Summary of the Invention

[0001] The present invention relates generally to an electrician's fish tape housing. More specifically, the invention relates to a translucent or clear housing for the fish tape, which allows a user to observe the coiled tape within the housing without removing the tape from the housing.

[0002] A fish tape is an electrician's tool which is used to install wires in a conduit. A fish tape is an elongated member made of tempered spring steel, stainless steel, nylon, fiberglass with a nylon jacket, or multi-stranded steel wire. The fish tape is rigid enough to be pushed through a conduit yet flexible enough to bend around corners or curves in the conduit. After the tape has been "fished" or threaded through a conduit, a wire or cable is attached to the end of the fish tape and the tape is pulled back through the conduit, drawing the wire it with it to install the wire in the conduit.

[0003] Fish tapes are supplied in lengths ranging from 20 to 240 feet. Due to the length of the fish tape, it is usually coiled for manageability. However, the natural resilience of the material makes the coil unruly. The material at all times wants to escape the confines of the coil. That is, it seeks to return to its natural straight condition and thus wants to "spring out" of its coiled condition. Accordingly, the fish tape must be housed in some manner to maintain it in a coiled condition until it is ready to be used.

[0004] Traditionally, a housing of some sort has been used to constrain the coils of the fish tape within a chamber formed in the housing. The chamber's walls confine the coil and prevent its natural release. An opening for threading the tape through the housing is provided. In some models, a handle travels around the periphery of the housing, widening a slot to direct the tape's exit from and entry into the housing. In the past the housing has been made of an opaque plastic or steel material that does not allow the user to see the tape within the housing.

[0005] The conventional opaque housing of the fish tape presents a number of problems. Because an electrician may not be able to observe how much tape is within the housing, he or she may have to guess, or even try a number of different tapes to determine whether the tape is of the needed length. Further, an electrician must pull the tape out of the housing in order to determine if the tape is in condition to be used again or if wear and tear or corrosion has rendered it unfit. These difficulties require extra time and effort on the part of the electrician, and result in added expense. While some prior art housings contain small viewing holes in the sides of the case, these are not adequate for determining the quantity and quality of the tape inside. The present invention remedies the problems of an opaque housing.

[0006] The present invention provides a translucent

or transparent housing. The translucent housing allows users of fish tapes to save time and expense by observing the condition, type and amount of tape within the housing without the added effort of removing the tape.

Brief Description of the Drawings

[0007] Fig. 1 is side elevation view of the translucent housing and shows a handle between the two halves of the housing.

[0008] Fig. 2 is a front elevation view of the translucent fish tape housing with the coiled tape visible within the chamber formed by the housing's walls.

Detailed Description of the Invention

[0009] The fish tape housing of the present invention is shown generally at 10. The fish tape housing 10 is made out of any lightweight, translucent material. The term "translucent" as used herein is intended to include any material that allows sufficient light to pass through such that the fish tape is observable as it rests in the housing. Thus, the term includes materials that pass so much light that they might be considered transparent, as well as those materials that pass less light than a transparent material. An example of a suitable material is the thermoplastic resin sold by General Electric Company under their trademark Xylex®. The translucent nature of the housing 10 allows a user to observe the coiled fish tape 12 within the housing 10. The fish tape shown has a fiberglass core surrounded by a nylon jacket. An eyelet 14 is fixed to the end of the fish tape to permit ready attachment of a wire or cable.

[0010] The housing 10 comprises inner and outer annular walls 16 and 18 which extend parallel to the axis 20 of the housing. First and second radial walls 22 and 24 join the annular walls. The second radial walls define a central opening 26. While it is not necessary to have a central opening it is preferred because it makes it easier to grasp the housing. Together the annular walls and radial walls define a chamber 28 in which the fish tape 12 resides when the tape is not in use. In a typical arrangement, the housing is split into two identical halves 30 and 32. The halves 30 and 32 are joined together in facing relation. Each half includes one of the radial walls and about half of each annular wall. Thus, housing half 30 includes first radial wall 22 and annular half-wall portions 16A and 18A while housing half 32 has second radial wall 24 and annular half-wall portions 16B and 18B. Each half therefore defines a generally U-shaped cross section. The open sides of the cross sections face one another with the half-wall portions in alignment with one another. This defines the chamber 28 in the space within the halves 30 and 32. The housing 10 restrains the coiled tape 12 within this space.

[0011] A handle 34 may be rotatably attached to the housing. A lower portion of the handle 34 is located generally between the halves and includes channels which

interfit with the edges of the outer annular half-wall portions 18A and 18B, allowing the handle to travel circumferentially around the housing 10. The handle further includes an aperture 36 through which the fish tape is threaded. As the handle travels, it separates the halves 30 and 32 slightly at the location of the handle. This opens a local slot 38 between the outer annular half-wall portions 18A, 18B of the housing. The slot 38 provides a space through which the tape 14 may emerge from within the housing chamber when the tape is being played out. Similarly, when the tape is returned into the housing it does so through slot 38. Other arrangements for getting the fish tape in and out of the housing are possible, such as the drum mounted fish tape shown in U.S. Patent 5,423,516, the disclosure of which is incorporated herein by reference.

[0012] The translucent housing 10 enables a user to determine the type, length and remainder of the coiled tape 12 within its chamber. It is preferred that the entire housing is translucent since this will permit observation of the tape regardless of the orientation of the housing relative to the observer. However, it will be realized that the less than all of the housing could be translucent and still allow observation of the tape in the housing. For example, one housing half could be translucent while the other is not. Or the radial walls 22, 24 could be translucent while the annular walls 16, 18 are not.

[0013] While a preferred form of the invention has been shown and described, it will be realized that alterations and modifications may be made thereto without departing from the scope of the following claims.

Claims

1. A fish tape housing comprising first and second radial walls joined by an outer annular wall to define a chamber in which a fish tape resides, at least a portion of one of said walls being translucent.
2. The fish tape housing of claim 1 wherein said first radial wall is translucent.
3. The fish tape housing of claim 2 wherein said second radial wall is translucent.
4. The fish tape housing of claim 3 wherein said annular wall is translucent.
5. The fish tape housing of claim 1 further comprising an inner annular wall joining the first and second radial walls.
6. The fish tape housing of claim 5 wherein said inner annular wall comprises first and second half-wall portions joined to the first and second radial walls respectively, and the outer annular wall comprises first and second half-wall portions joined to the first

and second radial walls respectively.

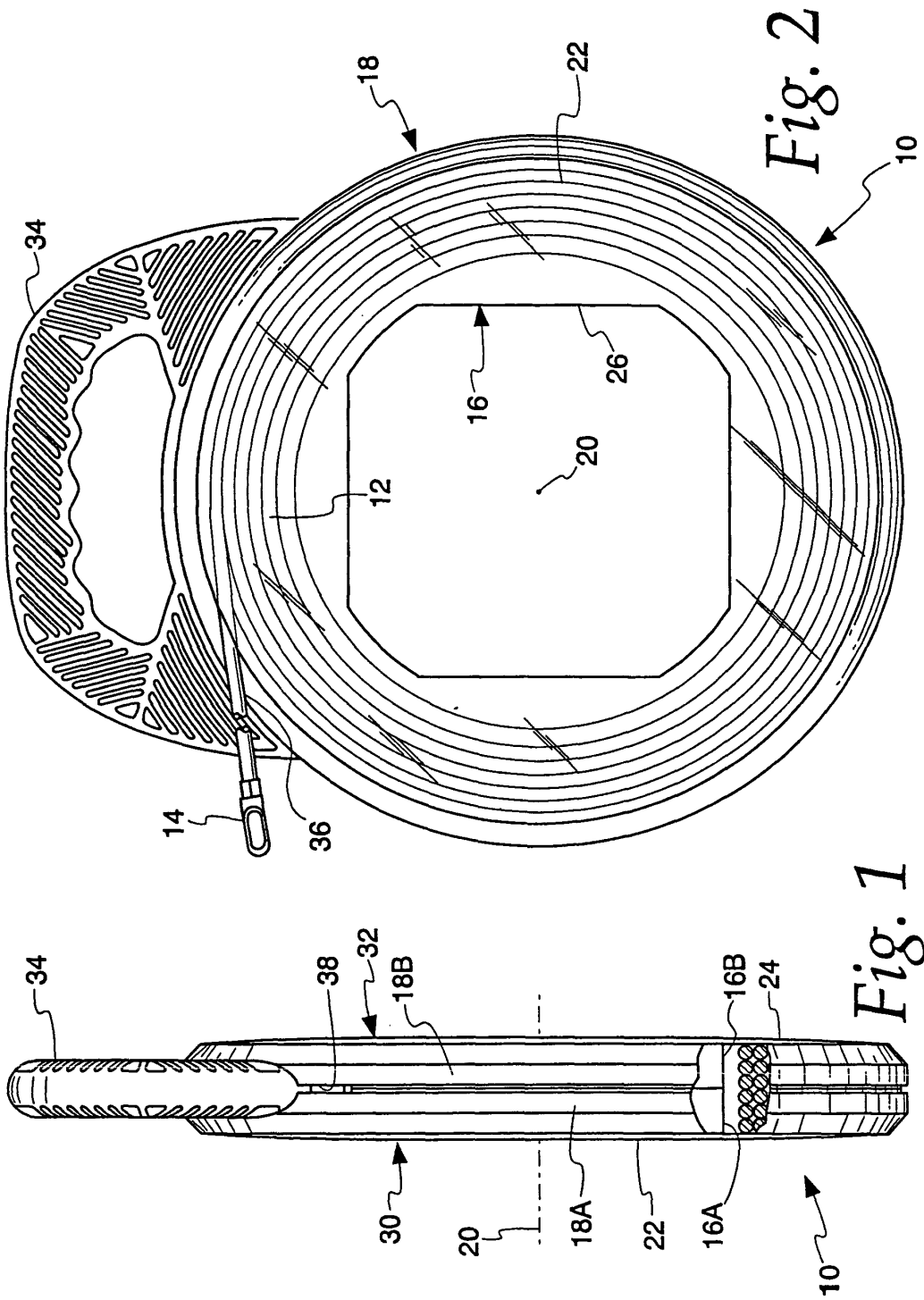



European Patent
Office

EUROPEAN SEARCH REPORT

Application Number
EP 03 25 5044

DOCUMENTS CONSIDERED TO BE RELEVANT			
Category	Citation of document with indication, where appropriate, of relevant passages	Relevant to claim	CLASSIFICATION OF THE APPLICATION (Int.CI.7)
X	US 3 355 123 A (W.G. SCHINSKE) 28 November 1967 (1967-11-28) * column 2, line 33 - line 58 * ---	1-6	B65H75/36
X	US 6 152 395 A (A. CORRIVEAU ET AL.) 28 November 2000 (2000-11-28) * column 9, line 38 - line 57 * ---	1-6	
A	US 5 697 572 A (J. SALENTINE ET AL.) 16 December 1997 (1997-12-16) * column 3, line 61 - line 67; claim 3 * -----	1	
The present search report has been drawn up for all claims			TECHNICAL FIELDS SEARCHED (Int.CI.7)
			B65H
Place of search	Date of completion of the search	Examiner	
THE HAGUE	10 December 2003	D'Hulster, E	
CATEGORY OF CITED DOCUMENTS		T : theory or principle underlying the invention E : earlier patent document, but published on, or after the filing date D : document cited in the application L : document cited for other reasons & : member of the same patent family, corresponding document	
X : particularly relevant if taken alone Y : particularly relevant if combined with another document of the same category A : technological background O : non-written disclosure P : intermediate document			

EPO FORM 1503 03 B2 (P0401)

**ANNEX TO THE EUROPEAN SEARCH REPORT
ON EUROPEAN PATENT APPLICATION NO.**

EP 03 25 5044

This annex lists the patent family members relating to the patent documents cited in the above-mentioned European search report. The members are as contained in the European Patent Office EDP file on The European Patent Office is in no way liable for these particulars which are merely given for the purpose of information.

10-12-2003

Patent document cited in search report	Publication date	Patent family member(s)	Publication date
US 3355123 A	28-11-1967	NONE	
US 6152395 A	28-11-2000	CA 2236726 A1 CA 2257553 A1 AT 235416 T AU 4025799 A CA 2331637 A1 WO 9962808 A1 DE 69906281 D1 EP 1082263 A1	29-11-1999 14-07-2000 15-04-2003 20-12-1999 09-12-1999 09-12-1999 30-04-2003 14-03-2001
US 5697572 A	16-12-1997	NONE	