



(12) **EUROPEAN PATENT APPLICATION**

(43) Date of publication:  
**17.03.2004 Bulletin 2004/12**

(51) Int Cl.7: **E06B 9/40, E06B 9/66**

(21) Application number: **03077459.0**

(22) Date of filing: **06.08.2003**

(84) Designated Contracting States:  
**AT BE BG CH CY CZ DE DK EE ES FI FR GB GR  
HU IE IT LI LU MC NL PT RO SE SI SK TR**  
Designated Extension States:  
**AL LT LV MK**

(72) Inventor: **Vervaeke, Geert**  
**8755 Ruiselede (BE)**

(74) Representative: **Ostyn, Frans et al**  
**K.O.B. NV,**  
**Kennedypark 31 c**  
**8500 Kortrijk (BE)**

(30) Priority: **10.09.2002 DE 20214076 U**

(71) Applicant: **Vervaeke bvba**  
**8755 Ruiselede (BE)**

(54) **Device for screening off a space**

(57) A device for screening off a space, comprising an upper (3) and a lower roller system (4), provided for winding and unwinding a screen (2), in which:

- the screen (2) is essentially longer than the distance (X) between the upper (3) and the lower roller system (4),
- the upper (3) and lower roller system (4) are provided with an upper (5) and a lower winding element (6) respectively, provided to wind and unwind the

screen (2)

driving means being provided to produce the motion for winding and unwinding the upper (5) or the lower winding element (6), said upper (5) or lower winding element (6) being provided with tightening means (13) in order to compensate the difference in diameter between the upper (5) and the lower winding element (6), and transmission means (9) being provided in order to transmit the motion for winding or unwinding the lower (5) or the upper winding element (6) or the other way round.

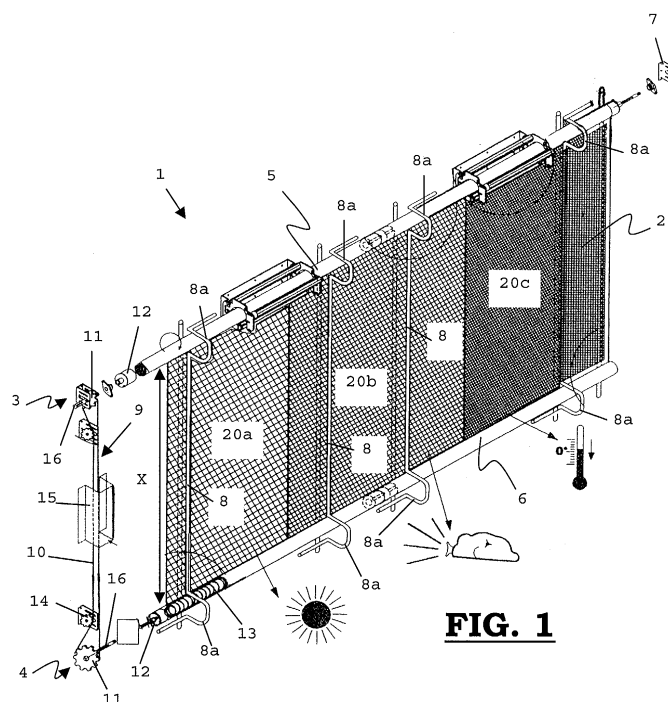

**FIG. 1**

## Description

**[0001]** The invention relates to a device for screening off a space, comprising an upper and a lower roller system, provided for rolling up and down the screen, in which:

- the screen is essentially longer than the distance between the upper and the lower roller system,
- the upper and lower roller systems being provided with an upper and a lower winding element respectively, provided to wind the screen up and down.

**[0002]** Up to the present such a device is known from U.S. 4,766,941 in which an electrically driven window screening is described with selectively variable screening characteristics, which may be installed in a window opening for selectively blocking (by absorption or reflection), filtering and/or allowing the light to pass the window screening into a room for purposes such as energy control and/or decoration, etc. This window screening comprises an upper roller system, a lower roller system and a long, flexible screen which is wound around the upper and the lower roller systems, the screen being essentially longer than the distance between the upper and the lower roller system. Each of these roller systems comprises a long tube-shaped roller, supports which may be connected to the extremity of the roller for rotatably fixing the extremity of the rollers with respect to the window. The screen is wound up and down from the rollers, while they are rotating around their respective longitudinal axes. For each roller a drive is provided in order to drive the roller in either direction in order thus to wind the screen from one of the rollers onto the other roller. The drive comprises a direct drive motor, comprising an output shaft, being essentially coaxial with respect to the direct drive motor, and the direct drive motor being provided within the roller, the output shaft being coaxial with respect to the roller. The direct drive motor is attached to the frame in order to prevent it from rotating. Furthermore, each direct drive motor is provided with a torsion spring in order to maintain the screen tightened when it is wound up or unwound from one roller onto the other and when the screen is stationary and to compensate any changes in rotating speed when the screen is wound up or unwound. More particularly, this torsion spring functionally connects the output shaft of each direct drive motor to the respective roller. The torsion spring of one of the rollers is wound in one direction (e.g. clockwise), while the other spring, which is connected to the other direct drive motor is wound in the opposite direction (e.g. anti-clockwise), so that, when starting either of the direct drive motors differences as to rotational speed and starting time of the direct drive motors may be compensated.

**[0003]** The disadvantage of such a device is, that two motors are used. Providing two motors has an adverse effect on the prime cost of the device and requires more

maintenance. As these two motors have to ensure that one roller is wound up and the other roller is unwound, some sort of synchronisation between these two motors is required, which is not a simple matter.

**[0004]** The purpose of the invention is to provide a device for screening off a space, not having these drawbacks.

**[0005]** This purpose is attained by providing a device for screening off a space, comprising an upper and a lower roller system for winding up and unwinding the screen, in which:

- the screen is essentially longer than the distance between the upper and the lower roller system,
- the upper and lower roller systems are provided with an upper and a lower winding element respectively, provided to wind and unwind the screen,

but in which driving means are provided for driving the winding and unwinding motions of the upper or the lower winding element, said upper or lower winding element being provided with tightening means, in order to compensate the difference in diameter between the upper and the lower winding element and transmission means being provided in order to transmit the winding and unwinding motion of the lower and the upper winding elements or the other way round.

**[0006]** This has the advantage that maintenance is required for only one set of driving means, and no synchronization of the driving means of the upper and lower winding elements is needed, because these transmission means have been provided.

**[0007]** In a preferred embodiment of a device according to the invention, the transmission means comprise a chain for transmitting said winding and unwinding motion.

**[0008]** Another disadvantage of the known device described above is that both motors are provided within the upper and the lower roller respectively. Because the motors are provided within the rollers, maintenance and repairs on these motors has become more difficult.

**[0009]** An additional purpose of the invention consists in providing a device for screening off a space as described above, but where the motor is easily accessible, e.g. for carrying out maintenance and repairs.

**[0010]** This purpose is attained by providing a device according to the invention, in which the driving means are provided with a motor installed outside the winding element.

**[0011]** In a preferred embodiment of a device according to the invention the motor is placed on the side where said chain has been provided.

**[0012]** This has the advantage that the motor has to exercise less power on the winding element that is driven in order to cause the other winding element to be rotated simultaneously.

**[0013]** Preferably, the motor is designed to produce the motion for winding and unwinding the lower winding

element.

**[0014]** In an advantageous embodiment of a device according to the invention, the screen is made up of one or several segments the gauze of which has different diameters.

**[0015]** In this manner, a different screen may be brought before the space, according to the weather conditions.

**[0016]** The invention will now be further explained by means of the following detailed description of a preferred device for screening off a space, according to the present invention. This description is only intended to give a clarifying example and to designate further advantages and particulars of the present invention, and therefore may on no account be interpreted as being a restriction of the field of application of the invention or of the patent rights set forth in the claims.

**[0017]** In this detailed description reference is made, by means of reference numbers, to the attached drawings, figure 1 of which is a perspective view of a device for screening off a space according to the invention.

**[0018]** A device (1) for screening off a space according to the invention, consists of a screen (2) which is longer than the distance (X) between the upper (3) and the lower roller system (4). The upper (3) and the lower roller system (4) respectively is provided with an upper (5) and a lower winding element (6) respectively, carried out in the form of a take-up roller, these take-up rollers (5,6) are intended for winding and unwinding the screen (2).

**[0019]** The upper roller system (3) is attached to a fixed support (not represented in the figure), by means of a connection (7). In this type, the lower roller system (4) is not attached, but might also be attached fixedly.

**[0020]** Both the upper (5) and the lower winding roller (6) are rotatably installed in one or several holders (8), which are provided with roller brackets (8a) in which the rollers may rotate and which are attached to a fixed support of the space to be screened off. The winding and unwinding motion of the winding rollers (5,6) is produced by means of a motor (not represented in the figure), which is connected to the lower winding roller (6) by means of a shaft stub (12) and a coupling shaft (16) for the shaft stub (12). Consequently, the motor is provided outside the lower winding roller (5). It should be noted that the motor may also be connected to the upper winding roller (5).

**[0021]** Furthermore, transmission means (9) are provided in order to transmit the motion for winding and unwinding the lower winding roller (6) to the upper winding roller (5). When the motor is connected to the upper winding roller (5) the motion for winding and unwinding the upper winding roller (5) will be transmitted from the upper winding roller (5) to the lower winding roller (6). These transmission means (9) comprise a chain (10) running over two chain wheels (11). These chain wheels (11) are provided on the coupling shaft (16). In this manner because of the chain (10) the upper winding roller

(5) will also rotate when the lower winding roller (6) is rotating. In this manner, the screen (2) will be unwound from the one roller and be taken up by the other roller. Furthermore, the chain (10) will be tightened by means of a chain tightener (14). Furthermore, a guard casing (15) is provided, in order to protect the chain (10) when moving.

**[0022]** Preferably the motor is provided on the same side as the chain (10), such that the motor will have to exercise less power on the lower winding roller (6) to cause the upper winding roller (5) to be rotated at the same time. In order to compensate the difference in diameter between the upper (5) and the lower winding roller (6), the lower winding roller (5) is provided with a tension spring (13).

**[0023]** The screen (2) is provided with one or several segments (20a, 20b, 20c) each having a different diameter of the gauze. In figure 1, these segments (20a, 20b, 20c) are represented next to one another, but actually these segments (20a, 20b, 20c) are installed underneath one another over the screen (2). These segments (20a, 20b, 20c) are brought before the space to be screened off, depending on the weather conditions. In figure 1:

- segment 20a is used in case the sun is shining outside;
- segment 20b is used for stormy weather conditions outside;
- segment 20c is used when it is freezing outside.

**[0024]** This device may be applied, for instance, in cowsheds, which does not mean that it may not be used for other applications.

### Claims

1. A device for screening off a space, comprising an upper (3) and a lower roller system (4), provided for winding and unwinding the screen (2), in which:

- the screen (2) is essentially longer than the distance (X) between the upper (3) and the lower roller system (4),
- the upper (3) and lower roller system (4) are provided with an upper (5) and a lower winding element (6) respectively, provided to wind and unwind the screen (2),

**characterized in that** driving means are provided for producing the motion for winding and unwinding the upper (5) or the lower winding element (6), said upper (5) or lower winding element (6) being provided with tightening means (13) to compensate the difference in diameter between the upper (5) and the lower winding element (6), and transmission means (9) being provided for transmitting the mo-

tion for winding and unwinding from the lower (5) to the upper winding element (6) or the other way round.

2. Device according to claim 1, **characterized in that** the transmission means (9) comprise a chain (10) for transmitting said motion for winding and unwinding. 5
3. Device according to claim 1 or 2, **characterized in that** the driving means are provided with a motor which is installed outside the winding element (5 or 6). 10
4. Device according to any one of the claims 2 up to and including 4, **characterized in that** the motor is installed on the side, where said chain (10) is provided. 15
5. Device according to claim 3 or 4, **characterized in that** the motor is designed for driving the motion for winding and unwinding the lower winding element (6). 20
6. Device according to any one of the claims, **characterized in that** the screen (2) consists of one or several segments (20a, 20b, 20c) each having a different gauze diameter. 25

30

35

40

45

50

55

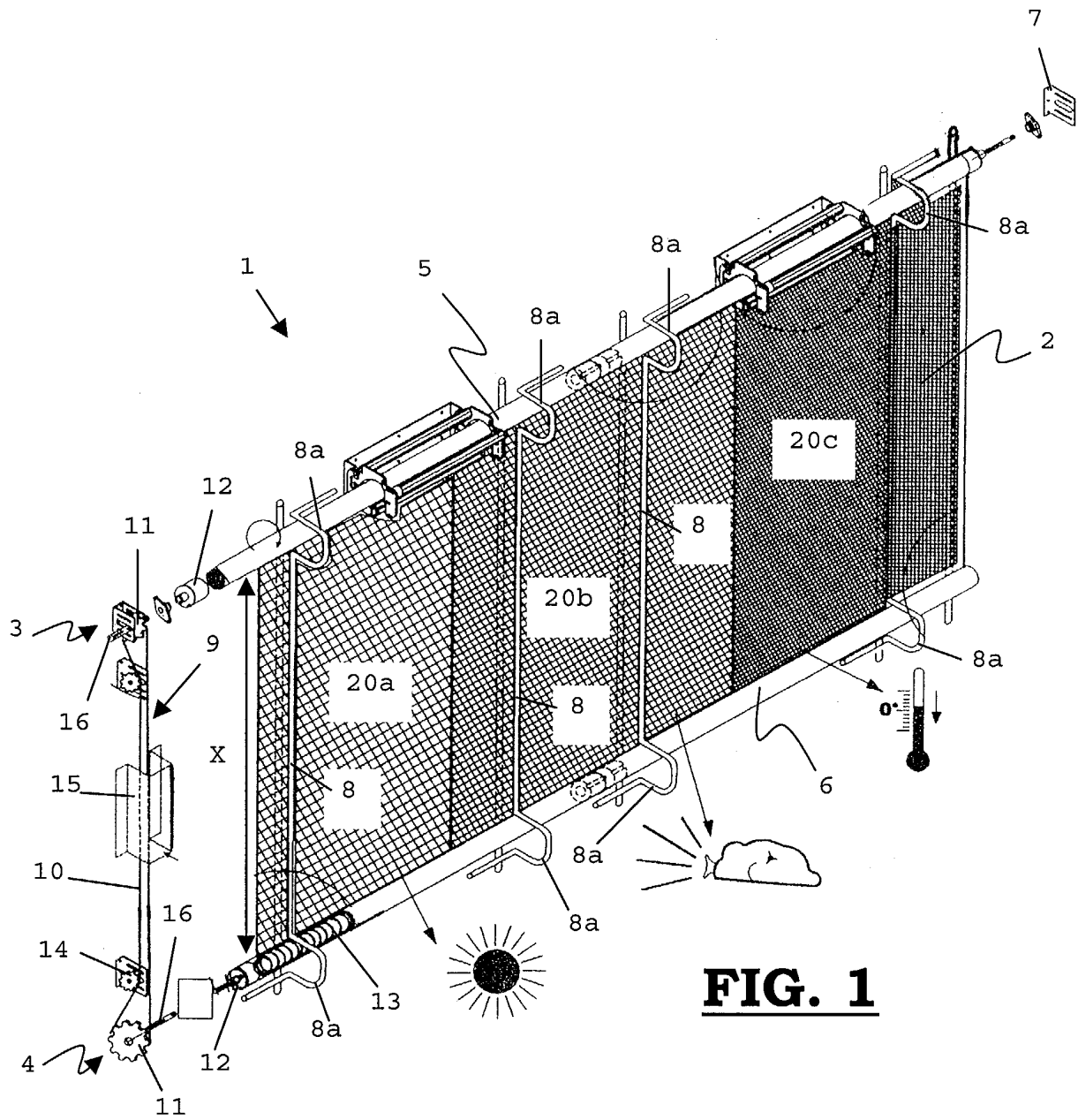

**FIG. 1**



European Patent  
Office

EUROPEAN SEARCH REPORT

Application Number  
EP 03 07 7459

DOCUMENTS CONSIDERED TO BE RELEVANT			
Category	Citation of document with indication, where appropriate, of relevant passages	Relevant to claim	CLASSIFICATION OF THE APPLICATION (Int.Cl.7)
A	US 4 815 515 A (LEE SONG L) 28 March 1989 (1989-03-28) * column 3, line 58 - column 4, line 14; figure 2 *	1	E06B9/40 E06B9/66
A	--- US 1 539 774 A (RYUJI SATO) 26 May 1925 (1925-05-26) * page 1, line 79 - line 84 *	1	
D,A	--- US 4 766 941 A (SLOOP DAVID J ET AL) 30 August 1988 (1988-08-30) * abstract; figure 1 *	1	
			TECHNICAL FIELDS SEARCHED (Int.Cl.7)
			E06B
The present search report has been drawn up for all claims			
Place of search		Date of completion of the search	Examiner
MUNICH		12 December 2003	Peschel, G
CATEGORY OF CITED DOCUMENTS			
X : particularly relevant if taken alone Y : particularly relevant if combined with another document of the same category A : technological background O : non-written disclosure P : intermediate document		T : theory or principle underlying the invention E : earlier patent document, but published on, or after the filing date D : document cited in the application L : document cited for other reasons & : member of the same patent family, corresponding document	

EPO FORM 1503 03 82 (P04C01)

**ANNEX TO THE EUROPEAN SEARCH REPORT  
ON EUROPEAN PATENT APPLICATION NO.**

EP 03 07 7459

This annex lists the patent family members relating to the patent documents cited in the above-mentioned European search report. The members are as contained in the European Patent Office EDP file on  
The European Patent Office is in no way liable for these particulars which are merely given for the purpose of information.

12-12-2003

Patent document cited in search report		Publication date		Patent family member(s)	Publication date
US 4815515	A	28-03-1989	GB	2205343 A	07-12-1988
US 1539774	A	26-05-1925	NONE		
US 4766941	A	30-08-1988	NONE		

EPO FORM P0459

For more details about this annex : see Official Journal of the European Patent Office, No. 12/82