



(12) **EUROPEAN PATENT APPLICATION**

(88) Date of publication A3:
20.07.2005 Bulletin 2005/29

(51) Int Cl.7: **B28B 7/36**, B28B 17/00,
G06F 17/60

(43) Date of publication A2:
31.03.2004 Bulletin 2004/14

(21) Application number: **03013430.8**

(22) Date of filing: **23.06.2003**

(84) Designated Contracting States:
**AT BE BG CH CY CZ DE DK EE ES FI FR GB GR
HU IE IT LI LU MC NL PT RO SE SI SK TR**
Designated Extension States:
AL LT LV MK

(72) Inventor: **Sergio Tosi**
41049 Sassuolo(MODENA) (IT)

(74) Representative: **Dall'Olio, Giancarlo**
INVENTION s.a.s.,
Via delle Armi, 1
40137 Bologna (IT)

(30) Priority: **24.06.2002 IT BO20020402**

(71) Applicant: **Serigrafica Tosi S.r.l.**
41059 Sassuolo (MO) (IT)

(54) **Method and apparatus for manufacturing means for making embossed decorations on ceramic tiles**

(57) According to a method for manufacturing means for making embossed decoration patterns on ceramic tiles, a die (M), defining a predetermined decoration pattern, is machined on a plate (3) of gummy material, by computer controlled laser. Then, the plate (3) is removably mounted on a punch (40) of a press (4) and a series of sample tiles (1) is press-died. In case of

a satisfying result, the production is started by the same punch (40) with the plate (3); otherwise, the corrections are made and other proofs are performed until the final decoration pattern is obtained; it is possible to start the production with the die (M) defining the final decoration pattern. When the die (M) is worn out, the plate (3) is replaced with another one carrying a new die (M), likewise obtained by laser technique.

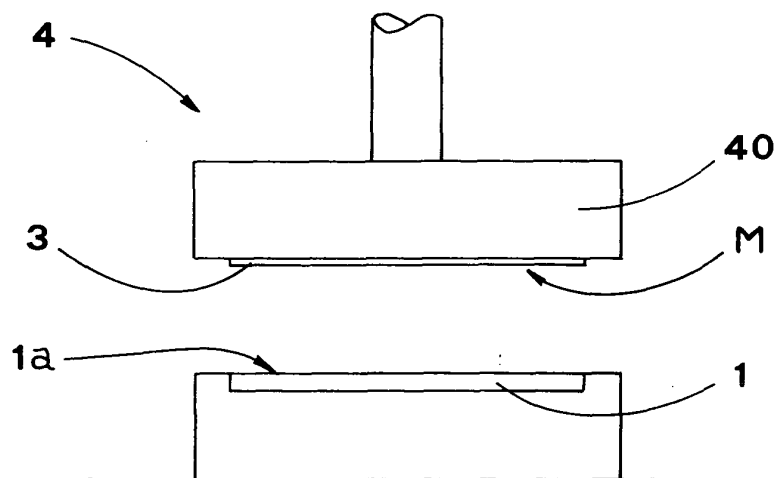

FIG. 2



DOCUMENTS CONSIDERED TO BE RELEVANT			
Category	Citation of document with indication, where appropriate, of relevant passages	Relevant to claim	CLASSIFICATION OF THE APPLICATION (Int.Cl.7)
A	US 5 922 260 A (ROSSI ET AL) 13 July 1999 (1999-07-13) * column 2, line 57 - column 3, line 34 * -----	1,2,9	B28B7/36 B28B17/00 G06F17/60
A	EP 1 083 062 A (TOSI, SERGIO) 14 March 2001 (2001-03-14) * paragraph [0010] * -----	1,2	
			TECHNICAL FIELDS SEARCHED (Int.Cl.7)
			B28B
The present search report has been drawn up for all claims			
Place of search The Hague		Date of completion of the search 30 May 2005	Examiner Roberts, P
CATEGORY OF CITED DOCUMENTS X : particularly relevant if taken alone Y : particularly relevant if combined with another document of the same category A : technological background O : non-written disclosure P : intermediate document		T : theory or principle underlying the invention E : earlier patent document, but published on, or after the filing date D : document cited in the application L : document cited for other reasons & : member of the same patent family, corresponding document	

EPO FORM 1503 03.82 (P04C01)

**ANNEX TO THE EUROPEAN SEARCH REPORT
ON EUROPEAN PATENT APPLICATION NO.**

EP 03 01 3430

This annex lists the patent family members relating to the patent documents cited in the above-mentioned European search report. The members are as contained in the European Patent Office EDP file on
The European Patent Office is in no way liable for these particulars which are merely given for the purpose of information.

30-05-2005

Patent document cited in search report		Publication date	Patent family member(s)	Publication date
US 5922260	A	13-07-1999	US 5714177 A	03-02-1998
EP 1083062	A	14-03-2001	IT M0990181 A1	08-03-2001
			EP 1083062 A2	14-03-2001