



(12) **EUROPEAN PATENT APPLICATION**

(88) Date of publication A3:
03.05.2006 Bulletin 2006/18

(51) Int Cl.:
H01H 33/34^(2006.01)

(43) Date of publication A2:
07.04.2004 Bulletin 2004/15

(21) Application number: **03018257.0**

(22) Date of filing: **11.08.2003**

(84) Designated Contracting States:
**AT BE BG CH CY CZ DE DK EE ES FI FR GB GR
HU IE IT LI LU MC NL PT RO SE SI SK TR**
Designated Extension States:
AL LT LV MK

- **Yaginuma, Noriyuki**
Chiyoda-ku,
Tokyo 100-8220 (JP)
- **Okubo, Kenichi**
Chiyoda-ku,
Tokyo 100-8220 (JP)
- **Ishiguro, Tetsu**
Chiyoda-ku,
Tokyo 100-8220 (JP)
- **Yaegashi, Masahiro**
Chiyoda-ku,
Tokyo 100-8220 (JP)

(30) Priority: **04.10.2002 JP 2002292216**

(71) Applicant: **Hitachi, Ltd.**
Chiyoda-ku,
Tokyo 100-8010 (JP)

(72) Inventors:
• **Kawamoto, Hideo**
Chiyoda-ku,
Tokyo 100-8220 (JP)

(74) Representative: **Strehl Schübel-Hopf & Partner**
Maximilianstrasse 54
80538 München (DE)

(54) **Gas insulated switchgear**

(57) The output shaft (111) of a hydraulic drive unit (110) and the drive shaft of a movable contactor (103) of gas insulated switchgear are linearly arranged, and the longitudinal shaft of an accumulator (114) using gas as an accumulation source is arranged parallel to the output shaft (111) of this hydraulic drive unit (110); further, a

high pressure block equipped with a conduit (115) for supplying high pressure hydraulic oil to the hydraulic drive unit (110) from this accumulator (114) is arranged perpendicularly to the aforementioned two drive shafts, thereby supporting and fixing the hydraulic drive unit in position.

FIG. 1

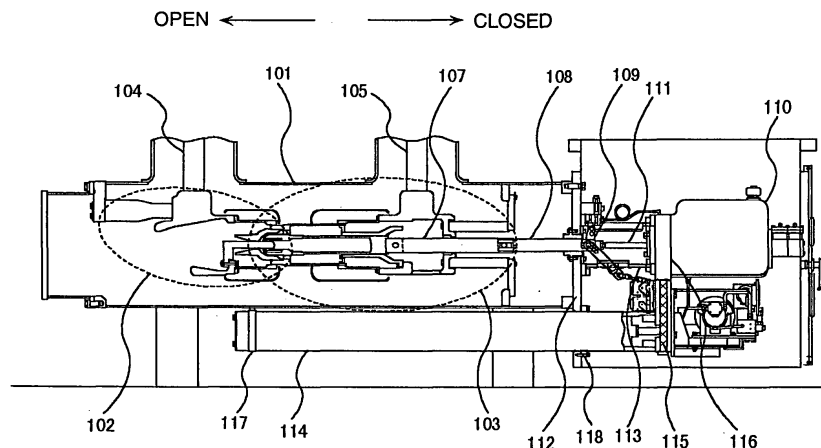



DOCUMENTS CONSIDERED TO BE RELEVANT			
Category	Citation of document with indication, where appropriate, of relevant passages	Relevant to claim	CLASSIFICATION OF THE APPLICATION (IPC)
D,A	PATENT ABSTRACTS OF JAPAN vol. 1998, no. 06, 30 April 1998 (1998-04-30) & JP 10 050181 A (TOSHIBA CORP), 20 February 1998 (1998-02-20) * abstract *	1	H01H33/34
A	----- US 3 766 343 A (GRATZMULLER J,FR) 16 October 1973 (1973-10-16) * abstract; figure 2 *	1	
A	----- US 3 761 735 A (TURNER J,US ET AL) 25 September 1973 (1973-09-25) * column 4, paragraph 2-4; claims; figures 8,9 *	1	
A	----- GB 823 444 A (JEAN LOUIS GRATZMULLER) 11 November 1959 (1959-11-11) * figure 1 *	1	
D,A	----- EP 0 240 884 A (BBC AKTIENGESELLSCHAFT BROWN, BOVERI & CIE) 14 October 1987 (1987-10-14) * abstract; figures *	1	
The present search report has been drawn up for all claims			TECHNICAL FIELDS SEARCHED (IPC)
			H01H
Place of search		Date of completion of the search	Examiner
The Hague		21 February 2006	Janssens De Vroom, P
<p>CATEGORY OF CITED DOCUMENTS</p> <p>X : particularly relevant if taken alone Y : particularly relevant if combined with another document of the same category A : technological background O : non-written disclosure P : intermediate document</p> <p>T : theory or principle underlying the invention E : earlier patent document, but published on, or after the filing date D : document cited in the application L : document cited for other reasons</p> <p>..... & : member of the same patent family, corresponding document</p>			

1
EPO FORM 1503 03.82 (P04C01)

**ANNEX TO THE EUROPEAN SEARCH REPORT
ON EUROPEAN PATENT APPLICATION NO.**

EP 03 01 8257

This annex lists the patent family members relating to the patent documents cited in the above-mentioned European search report. The members are as contained in the European Patent Office EDP file on
The European Patent Office is in no way liable for these particulars which are merely given for the purpose of information.

21-02-2006

Patent document cited in search report		Publication date	Patent family member(s)	Publication date
JP 10050181	A	20-02-1998	NONE	

US 3766343	A	16-10-1973	AT 316681 B	25-07-1974
			BE 775684 A1	23-05-1972
			CA 942625 A1	26-02-1974
			CH 545424 A	15-12-1973
			DE 2157154 A1	25-05-1972
			FR 2115506 A5	07-07-1972
			GB 1367688 A	18-09-1974
			IT 945071 B	10-05-1973
			NL 7115098 A	25-05-1972
			SE 376052 B	05-05-1975

US 3761735	A	25-09-1973	CA 975080 A1	23-09-1975

GB 823444	A	11-11-1959	DE 1132801 B	05-07-1962

EP 0240884	A	14-10-1987	CN 87102578 A	11-11-1987
			DE 3611501 A1	08-10-1987
			HU 44319 A2	29-02-1988
			JP 2010473 C	02-02-1996
			JP 7037801 B	26-04-1995
			JP 62237102 A	17-10-1987
			PL 264985 A1	31-03-1988
