

(19)



Europäisches Patentamt
European Patent Office
Office européen des brevets



(11)

EP 1 407 825 A1

(12)

EUROPEAN PATENT APPLICATION

(43) Date of publication:

14.04.2004 Bulletin 2004/16

(51) Int Cl.7: **B05B 11/00**

(21) Application number: **02022655.1**

(22) Date of filing: **10.10.2002**

(84) Designated Contracting States:
**AT BE BG CH CY CZ DE DK EE ES FI FR GB GR
IE IT LI LU MC NL PT SE SK TR**
Designated Extension States:
AL LT LV MK RO SI

(72) Inventor: **The designation of the inventor has not yet been filed**

(74) Representative: **Bosch, Henry et al
Monsanto Services International S.A.
Patent Department
Avenue de Tervuren 270/272
Letter Box No. 1
1150 Brussels (BE)**

(71) Applicant: **MONSANTO EUROPE S.A.
B-1150 Brussels (BE)**

(54) New spray bottle

(57) The current invention relates to a dispenser as exemplified in Figure 10 comprising a container (A) for holding a product to be dispensed and a dispensing mechanism (B), said dispenser comprises

- i. a container body (Q) having a bottom (E), and a means for interconnecting said bottom with a side opposite thereto; said container body further including at least one outlet opening (F) arranged in or near the side opposite to said bottom, preferably in or near the upper half of the means interconnecting the bottom with the side opposite to said bottom,

- ii. a conduct (G) connecting said container body, extending from the outlet opening (F), with said dispensing mechanism,
- iii. a trigger sprayer (H) and,
- iv. a neck (K) connecting said trigger sprayer (H) with said conduct (G)

characterized in that, said neck (K) and said conduct (G) are linked to said container body (Q) so that said neck (K) and said conduct (G) form a swan-neck or a U-shape extending from said outlet opening (F) so as to exchange air pressure and product to be dispensed.

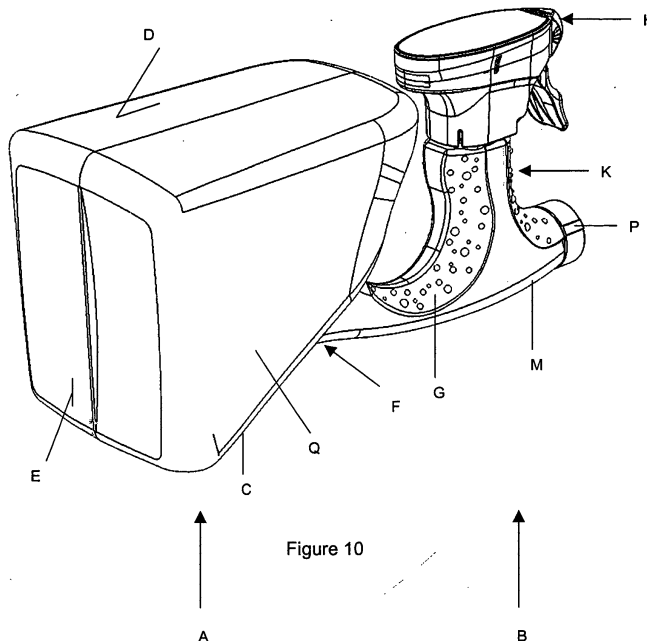

EP 1 407 825 A1

Description

[0001] The present invention relates to a dispenser comprising a container for holding a product to be dispensed, said container having a container body with a bottom, a top and at least one side wall interconnecting said bottom and top, said container body further including at least one outlet opening arranged in the top part of the container body, but preferably in or near said bottom, and a dispensing mechanism interconnectingly arranged on said at least one outlet opening.

[0002] Dispensers are generally well known in the art. Prior art dispensers of the general type typically include a bottle having a neck at the top, and a dispensing mechanism, for instance a trigger sprayer, attached to the neck. The trigger sprayer may be attached to the bottle in any conventional way, e.g. by a threaded connection, a bayonet connection or a snap connection.

[0003] Alternatively, part of the trigger sprayer may be integrated with the bottle.

[0004] Trigger sprayers are well known in the art. A problem with dispensers known in the art comprising a container for holding a product to be dispensed is that those containers, when (completely) filled, are mostly uncomfortable as a result of the weight of the liquid contained therein. The filled dispenser as such therefore can sometimes be heavy and not easy in its use.

[0005] Classical dispensers with the dispensing mechanism attached at the top of the container, mostly threaded thereto, have the disadvantage that the wrist and/or forearm of the person using the dispenser are heavily forced. In using those classical dispensers the wrist has to move up and down in addition to inward and outward movement of the wrist. It is clear that such movements can lead to medical problems at the wrist and/or forearm of a person using those dispensers.

[0006] In addition classical dispensers as described here above have the disadvantage that there is always a leftover of liquid in the bottle of about the size of the bottom of the bottle. It is practically impossible to completely empty the bottle in the classical dispensers.

[0007] Classical dispensers must normally be used in an upright position. When used under an inclination, e.g. when spraying onto the soil, leakage problems along the trigger sprayer often occur. So dispensers known in the art cannot be conveniently used under an inclination, especially when the dispensers are directed to the soil surface.

[0008] The above-mentioned drawbacks are solved in the provision of the current dispenser.

[0009] The current invention thus relates to a dispenser as exemplified in Figure 10 comprising a container (A) for holding a product to be dispensed and a dispensing mechanism (B), said dispenser comprises

a) a container body (Q) having a bottom (E), and a means for interconnecting said bottom with a side opposite thereto; said container body further including at least one outlet opening (F) arranged in or near the side opposite to said bottom, preferably in or near the upper half of the means interconnecting the bottom with the side opposite to said bottom,

b) a conduct (G) connecting said container body, extending from the outlet opening (F), with said dispensing mechanism,

c) a trigger sprayer (H) and,

d) a neck (K) connecting said trigger sprayer (H) with said conduct (G)

characterized in that, said neck (K) and said conduct (G) are linked to said container body (Q) so that said neck (K) and said conduct (G) form a swan-neck or a U-shape extending from said outlet opening (F) so as to exchange air pressure and product to be dispensed.

The means for interconnecting the bottom of the container body and the side opposite thereto can be either a cylinder, like a bottle, or have a cubical shape wherein this cubic form comprises side walls, preferably at least 4 side walls (C, D,...) interconnecting the bottom with the side opposite thereto. Alternatively the container body can have a triangular form as well.

In a preferred embodiment the inventive dispenser has a protrusion (M) arranged close to the trigger sprayer (H) such as to receive the end of a tube (N) attached to said trigger sprayer.

In another preferred embodiment the inventive dispenser has the protrusion (M) arranged in such a manner extending the conduct (G) as to receive a tube (N) which is attached to the sprayer.

In another embodiment the dispenser has the protrusion (M) arranged in a manner extending the neck (K) as to receive a tube (N) attached to the sprayer.

Alternatively the dispenser according to the invention has the protrusion (M) arranged in the neck (K) in such a manner as to receive a tube (N) attached to the sprayer.

In order to overcome the disadvantages (such as forced wrist and/or forearm) associated with the use of classical sprayers which are mostly heavily loaded with liquid, the dispenser according to the current invention is characterized in that the container body is shaped in such a manner that the container body is resting on the forearm of a human

being using the dispenser.

More in particular the sidewall (C) of said container body is shaped in such a manner that said sidewall is resting on the forearm of a human being when in use.

For ease of filling the dispenser with liquid the protrusion (M) contains an opening means (P) with closure means, so that the sprayer does not have to be removed from the neck of the dispenser. Alternatively, the dispenser according to the invention comprises an opening for filling in its bottom (E) and/or in one or more of its sidewalls (C,D,...) and/or in its side opposite to said bottom.

[0010] The trigger sprayer (H) can be attached to the neck (K) in any conventional way e.g; by a threaded connection, a bayonet connection or a snap connection. However the trigger sprayer can also be integrated with the neck (K) and form one part.

The combination of the elements trigger sprayer (H), neck (K) and conduct (G) can also be attached to container body (Q) at the outlet opening (F) in any conventional way e.g; by a threaded connection, a bayonet connection or a snap connection, and may alternatively be integrated as one part with the container body (Q).

Suitable trigger sprayers are for instance trigger sprayers with a so-called precompression system. A precompression system may be placed between a pump and a discharge nozzle that are connected by a conduit debouching in a space, the system comprising a precompression valve movable between a position closing off the connection in which it abuts a seat on the mouth of the conduit and a position releasing the connection in which it is spaced from the seat, the precompression valve being biased to the closing position by spring means. Such a precompression system is known from e.g. USP 5,730,335 or WO 00/33970. Other trigger sprayers to be used on the current dispenser are those described in e.g. USP 4,706,888 and USP 6,126,090.

The dispenser according to the invention may thus comprise in its trigger sprayer as part of the dispensing mechanism (B) a so-called precompression system, although it is not essential for the performance of the current invention. Said dispenser may be equipped with other well known dispensing mechanisms without departing from the scope of the present invention.

[0011] The known precompression system is used in a sprayer head for a container, for instance a bottle, containing liquid. Such a sprayer head is formed by a body in which a manually operable piston pump is arranged. This pump is operated by a trigger that is pivotally connected to the body.

[0012] The suction side of the pump is connected to a tube (N) that extends into a bottle and through which liquid may be drawn out of the bottle.

The compression side of the pump is connected to the discharge nozzle of the sprayer head through a conduit.

Between the pump and the conduit leading to the discharge nozzle is arranged the precompression system, comprising a precompression valve that is kept shut by spring means and that is opened only when a predetermined pressure is attained within the pump. The precompression valve has for its object to prevent the fluid from leaving the discharge nozzle at too low a pressure, which would result in too large drops being formed in the spray.

In order to achieve an optimum spraying pattern the liquid must in fact be pressed out of the discharge nozzle at a predetermined and relatively high pressure.

[0013] There are several advantages using the inventive dispensers with the thus shaped container bodies according to the present invention.

Firstly there are ergonomic advantages. For the handgrip itself, there is a better grasping interface for left and right-handed users. There is no up and down movement of the wrist (so called radial and ulnar deviation) and in addition only a limited outward and inward movement of the wrist is necessary (so called dorsiflexion and palmar flexion of the wrist is allowed) to properly dispose the product contained in the dispenser. The working line of the spray liquid (the spraying action) is the normal working line of the wrist-arm alignment. The wrist alignment is achieved because of the geometric layout of the container or bottle according to the current invention. Another advantage due to the container in accordance with the invention is that the weight of said container, when filled, does not stress the wrist resulting in a much better comfort of use. The forearm supports the weight without bending the wrist. The weight of a classical container or bottle forces the wrist to misalign with the arm.

[0014] Secondly there are environmental advantages in using the dispenser according to the present invention. As exemplified in Figures 1-6, the tube (N) attached to the sprayer usually extends into the protrusion (M) in such a way that there is a minimal left-over of liquid in the bottle because of an optimal flow of liquid from the protrusion of the bottle or container to the sprayer. There is only a very little volume left at the end of the dip tube. A classical or standard spray bottle has a volume left over of about the size of the bottom of the bottle.

[0015] Thirdly the dispenser according to the present invention is safer with regard to leakage of liquid out of the container. With a normal classical fill as manufactured the chance for leaking of the inventive dispenser is much smaller compared to the dispensers known in the art. If the inventive dispenser falls over on its left or right side, there is 50% less chance for leaking, because the liquid hardly reaches the closing edge of the trigger sprayer because of the shape or design of the inventive dispenser but also of the presence of the air chamber designated as A in Figures 1-5. Liquid present in a classical dispenser always reaches the closure when falling on its left or right side resulting in sometimes

substantial leakage of the liquid out of the dispenser.

A standard trigger sprayer present on a classical spray bottle cannot conveniently be used under an inclination when the bottle is directed to the soil surface, for instance for spraying herbicides or spraying household cleaners, since it will start leaking after ± 5 trigger actions or when the trigger is continuously pushed in. This is because of the 'venting hole' present in the trigger spray system. It is needed to let air into the bottle to avoid creating a vacuum in the bottle. The dispenser according to the current invention causes no leaks because the air bubble (A in figures 1-5) prevents the liquid from flowing through the venting hole.

The inventive system prevents leakage during use because of the two communicating air chambers; one air chamber at front under trigger sprayer and one air chamber at back of bottle at top of bottle volume (see Figures 1-5).

[0016] Figures 1-6 show how the two air chambers (A and B) move while rotating the inventive dispenser.

While spraying (triggering movement) the air pressure in chamber B will drop because of liquid going out of the dispenser. Chamber A will stay at atmosphere pressure also based upon the principle of communicating vessels.

When the pressure in chamber B becomes too low (under pressure), air and pressure from chamber A is automatically transported to chamber B. At the same time, while triggering, chamber A will be filled with air again by venting. Venting is the air exchange between outside and inside air and is happening while the trigger is pressed in.

[0017] Information relating to the product contained in the bottle and/or to the way the dispensing mechanism can be operated is usually displayed on labels that are applied to the sides of the bottle or container. Therefore, to view this information, a prospective purchaser and/or user of the dispenser must hold the bottle up so high that the information on the labels on the sides of the bottle is visible.

[0018] In addition, purchasers of this type of dispensers usually store them in their homes in locations where they are easily accessed when needed. The dispensers are often stored in a cabinet beneath the sink of the home along with other cleaning and related products that are contained in bottles or dispensers, often bottles with trigger sprayers. When looking for a particular product contained in a bottle or dispenser that is stored beneath a sink, the user is often required to pick up each of the bottles and dispensers stored there to view the sides of the bottles and dispensers in order to determine their contents.

[0019] Incidentally, the same issue arises when bottles or dispensers are tightly packed in display racks in supermarkets, where a prospective purchaser will often have to pick up a bottle or dispenser in order to verify if it is the particular brand for which he/she is looking.

[0020] Part of the present invention is to provide a dispenser of the type described above in which the above discussed drawbacks associated with prior art dispensers are overcome. This is achieved in such a dispenser wherein the dispensing mechanism carries at least one label displaying information. With the information displayed on the dispensing mechanism, which is arranged on top of the bottle, it is not necessary to hold the dispenser up high in order to view the information. In this connection, the term "label" is intended to denote any object that is suitable for displaying information.

[0021] In a preferred embodiment of the dispenser, the dispensing mechanism includes at least one top surface, the at least one label being arranged on the top surface.

[0022] Furthermore, the information, which may include information on how to operate the dispensing mechanism, is then readily visible when the dispenser is held in the hand prior to or during its use.

[0023] In order to improve the impact and visibility of the information, the at least one label preferably displays the information in at least two different colors.

[0024] The information may relate to the product to be dispensed and/or to the use of the dispensing mechanism.

[0025] The invention will now be illustrated with reference being made to the annexed drawings (Figures 1- 19), in which like parts are identified by the same reference numerals:

Figure 1 represents an example of the inventive dispenser in an upright position

Figures 2-6 show spraying positions of the inventive dispenser

Figure 7 shows the condition when the bottle is positioned on the forearm before triggering is activated.

Figure 8 shows the condition when the bottle is positioned on the forearm while triggering is activated.

Figure 9 shows the condition when the bottle is positioned on the forearm during and after triggering is activated.

Figure 10: perspective view of a preferred embodiment

Figure 11: top view of a preferred embodiment

Figure 12: front view of a preferred embodiment

Figure 13: perspective view of a preferred embodiment

Figure 14: side view of a preferred embodiment

Figure 15: Alternative design. It shows a separate handle with a spray trigger and a separate container body. The container body (Q) is filled via outlet opening (F). The dip tube (N) extends from the sprayer head into the connecting cap. The container body locks to the handle via a connecting cap. With this concept there is no front air chamber.

Figure 16: shows three alternative designs according to the invention

EP 1 407 825 A1

Figure 17: shows the inventive dispenser with a container body (Q) in a cylindrical form

Figure 18: represents a dispenser according to the invention wherein the container body (Q) is a triangular form.

Figure 19: represents an alternative dispenser according to the invention.

5 Explanation of the Figures 1 to 6.

[0026] These figures show how the two air chambers (A and B) move while rotating the bottle.

Figures 2 to 6 show the spraying positions.

10 While spraying (triggering movement) the air pressure in chamber B will drop because of liquid going out of the bottle. Chamber A will stay at atmosphere pressure.

When the pressure in chamber B becomes too low (under pressure), air and pressure from chamber A is automatically transported to chamber B and liquid flows to the dispensing mechanism. At the same time, while triggering, chamber A will be filled with air again by venting.

15 **[0027]** Venting is air exchange between outside and inside air and is happening while trigger is pressed in.

Explanation of the Figures 7 to 9.

[0028] *Figure 7* shows the condition when the bottle is positioned on the forearm before triggering is activated.

[similar to positions in figures 2 to 5, without triggering activated]

20 At this condition the pressure in Pa1 is equal to the pressure in Pb1 plus the hydrostatic pressure (Ph) from liquid level difference C1.

Pb1 is at atmosphere pressure.

25 *Formula:* $Pa1=Pb1+Ph(C1)$

[0029] This results in liquid level A1 being in balance with liquid level B1, determined by the respective air chambers Pa1 and Pb1

[0030] *Figure 8* shows the condition when the bottle is positioned on the forearm while triggering is activated.

30 At this condition the venting hole is opened and the hydrostatic pressure forces the pressure in Pa1 to exchange with outside air until Pa2 is at atmosphere pressure. This results in liquid level A2 to rise while liquid level B2 drops.

At this moment Pb2 enters into under pressure.

[0031] *Figure 9* shows the condition when the bottle is positioned on the forearm during and after triggering is activated.

35 At this condition the venting hole is opened and closed. The liquid level A2 drops to A3 because of liquid taken out by the dip tube.

Pressure in Pb2 drops further to Pb3 and air/pressure exchange takes place when liquid level A3 is at level D3.

Air and pressure from chamber Pa3 is automatically transported to chamber Pb3 and liquid flows to the dispensing mechanism.

40 **[0032]** This is a continuous process of chamber Pa and Pb being in balance while the liquid level drops because of emptying the bottle by triggering.

[0033] Exchange of air pressure and liquid is under influence of shape and dimensions of the conduct and the viscosity of the liquid.

[0034] The abbreviations used in the Figures 7, 8 and 9 are explained hereafter:

- 45
- A: liquid level in handle
 - B: liquid level in container
 - C: height difference A-B
 - D: height to conduct
 - 50 Pa: pressure in chamber F
 - Pb: pressure in chamber G
 - E: cross section conduct
 - F: handle chamber
 - G: container chamber
- 55

The shaded area means content e.g. liquid present in the dispenser.

Conclusion to figures 1 to 6 and 7 to 9 explanation:

[0035] Exchange of air pressure and liquid is under influence of shape and dimensions of the conduct and the viscosity of the liquid.

[0036] Theoretical diameter of the conduct needed to exchange liquid (water) only:

1.13mm Ø

This is based on a continuous liquid flow of 1 ml/s, needed to feed liquid to the trigger sprayer.

| | |
|------------|---|
| Parameters | 3.6kg/hr = 1 ml/s |
| | 5cm ΔL = 0.005bar (hydrostatic pressure level difference) |
| | Ip = 1.000bar (internal pressure) |
| | Up = 0.995bar (external pressure) |
| | Δp = 0.005bar (pressure difference between internal and external) |

[0037] Theoretical diameter of the conduct needed to exchange air only:

0.23mm Ø

This is based on the above parameters and the following parameters.

| | |
|------------|-------------------------------|
| Parameters | 3.6kg/hr = 3.6Uhr |
| | 3.6 x 1.29gr = 4.644gr air/hr |

Because of capillary action the minimum diameter of the conduct is:

±2.5mm Ø

to exchange air and liquid via one conduct.

[0038] Therefore:

1) the minimum volume of the container body is 100 ml.

This is based on smallest reasonable selling item, practically every volume above 1ml will do.

2) minimum volume of dispenser unit is defined by the shape of the minimum needed handgrip of 2cm Ø and 4cm height (12.57ml)

3) minimum diameter of conduct is then 2.5mm Ø or 4.9mm²

4) the dip tube (N) has preferably a minimum diameter of about 3 mm

5) an alternative for 1 conduct (G) is to have 2 conducts: one for liquid exchange, another for air exchange, the latter positioned above the liquid level.

Claims

1. A dispenser comprising a container (A) for holding a product to be dispensed and a dispensing mechanism (B), said dispenser comprises

i. a container body (Q) having a bottom (E) , and a means for interconnecting said bottom with a side opposite thereto; said container body further including at least one outlet opening (F) arranged in or near the side opposite to said bottom, preferably in or near the upper half of the means interconnecting the bottom with the side opposite to said bottom,

- ii. a conduct (G) connecting said container body, extending from the outlet opening (F), with said dispensing mechanism,
- iii. a trigger sprayer (H) and,
- iv. a neck (K) connecting said trigger sprayer (H) with said conduct (G)

5

characterized in that, said neck (K) and said conduct (G) are linked to said container body (Q) so that said neck (K) and said conduct (G) form a swan-neck or a U-shape extending from said outlet opening (F) so as to exchange air pressure and product to be dispensed.

- 10 **2.** A dispenser according to claim 1 wherein the means for interconnecting the bottom with the side opposite thereto has a cylindrical form.
- 3.** A dispenser according to claim 1 wherein the means for interconnecting the bottom with the side opposite thereto has a cubical form comprising side walls, preferably at least four side walls (C, D,...) interconnecting said bottom (E) with said side opposite thereto.
- 15 **4.** A dispenser according to claim 1-3 wherein a protrusion (M) is arranged close to the trigger sprayer (H) such as to receive the end of a tube (N) attached to said trigger sprayer.
- 20 **5.** A dispenser according to claim 4 wherein the protrusion (M) extends the conduct (G) arranged in such a manner as to receive a tube (N) attached to the sprayer.
- 6.** A dispenser according to claim 4 wherein the protrusion (M) extends the neck (K) arranged in such a manner as to receive a tube (N) attached to the sprayer.
- 25 **7.** A dispenser according to claim 4 wherein the protrusion (M) is arranged in the neck (K) in such a manner as to receive a tube (N) attached to the sprayer.
- 8.** A dispenser according to claims 1-7 **characterized in that** the container body (Q) is shaped in such a manner that it is resting on the forearm of a user of the dispenser.
- 30 **9.** A dispenser according to claim 1-7 **characterized in that** the sidewall (C) of said container body (Q) is shaped in such a manner that said sidewall (C) is resting on the forearm of a user.
- 35 **10.** A dispenser according to any of the preceding claims wherein the protrusion (M) contains an opening means (P) and a closure means.
- 11.** A dispenser according to any of the preceding claims wherein the trigger sprayer (H) comprises a precompression system.
- 40 **12.** A dispenser according to any of the preceding claims wherein said dispensing mechanism carries, preferably arranged on its top surface, at least one label displaying content and users information.
- 45 **13.** A dispenser according to any of the preceding claims comprising an opening for filling in its bottom (E) and/or in one or more of its sidewalls (C,D,...) and/or in its side opposite to said bottom.

50

55

Fig. 1.

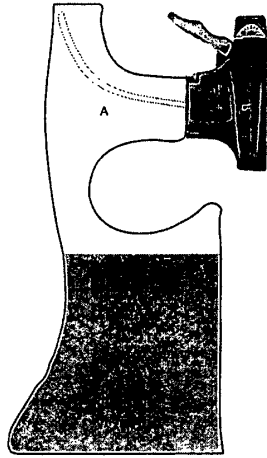

Fig. 2.

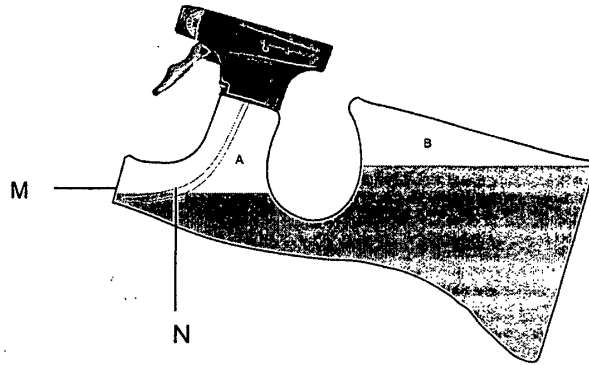

Fig. 3.

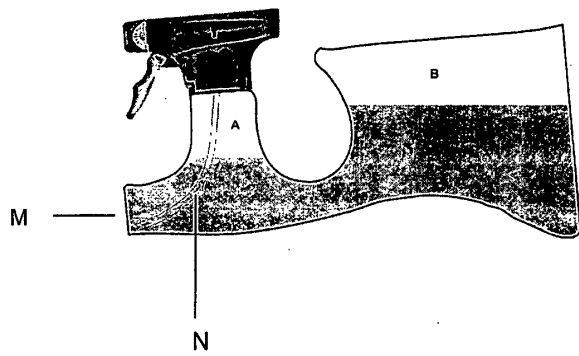

Fig. 4.

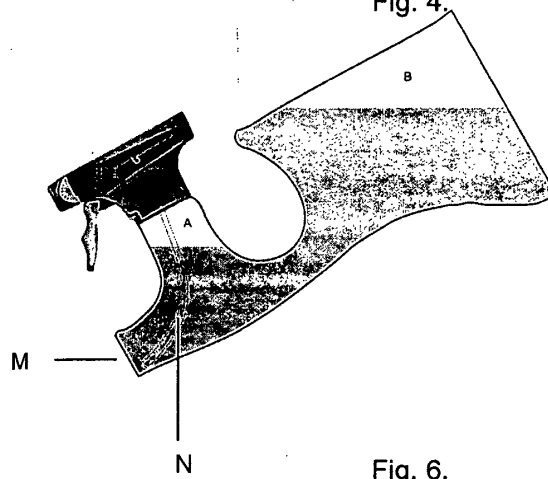

Fig. 5.

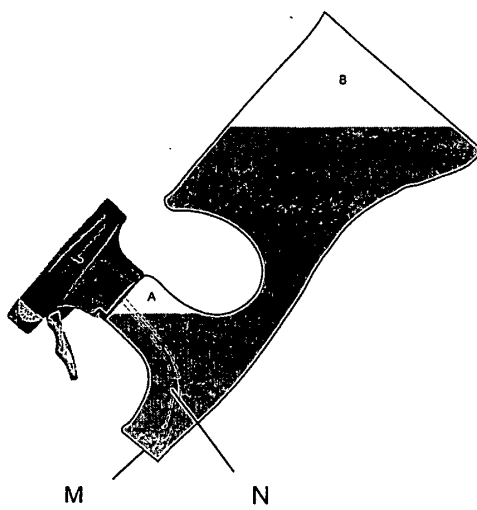
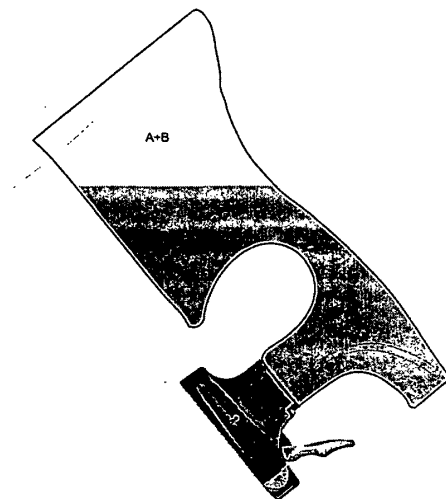
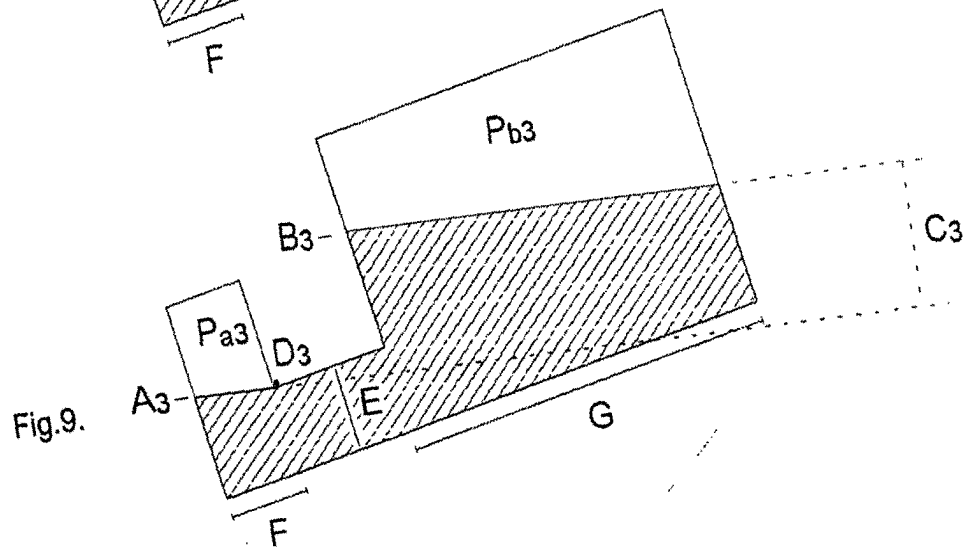
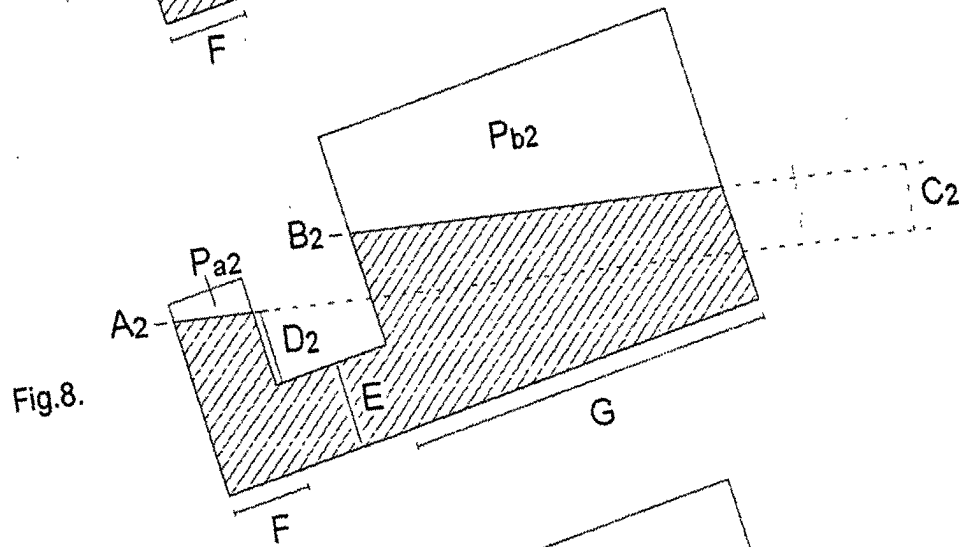
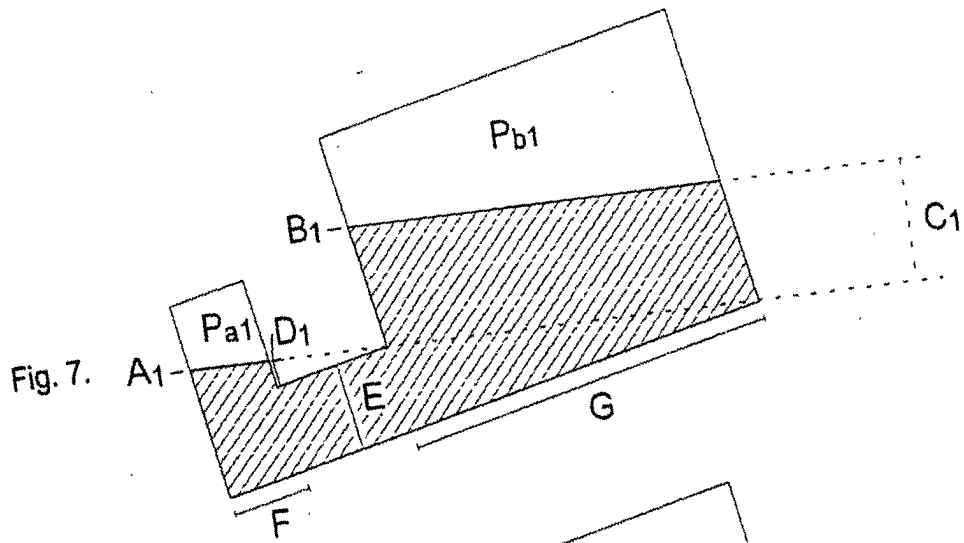

Fig. 6.





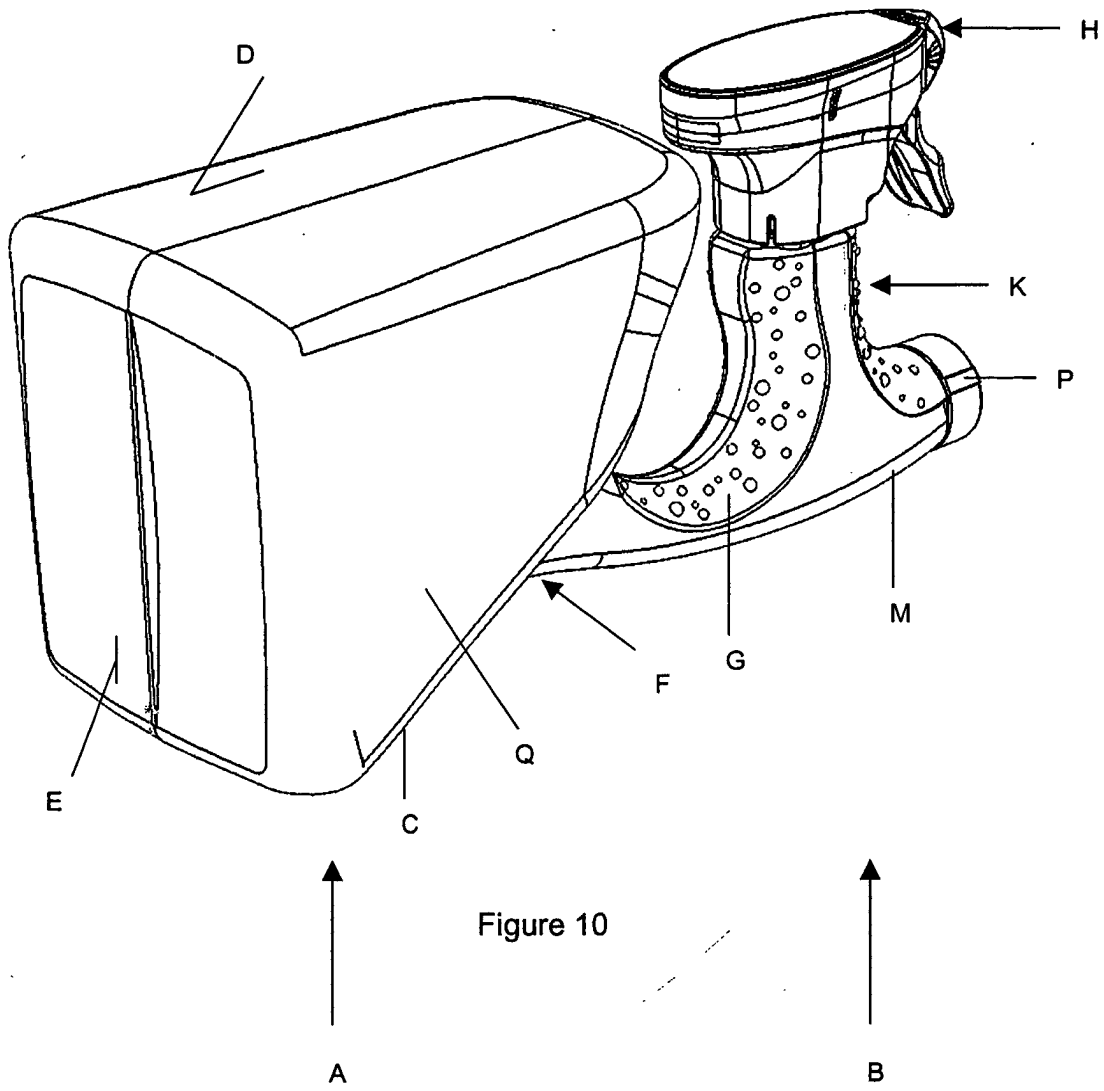

Figure 10

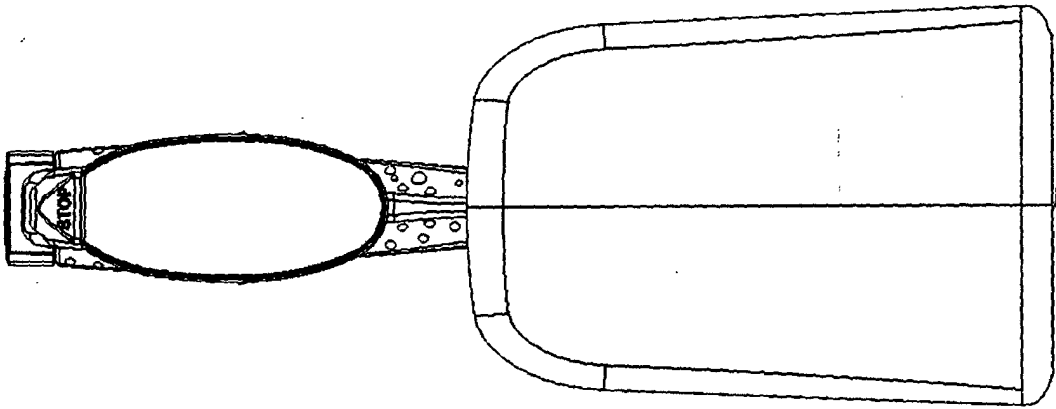

Figure 11

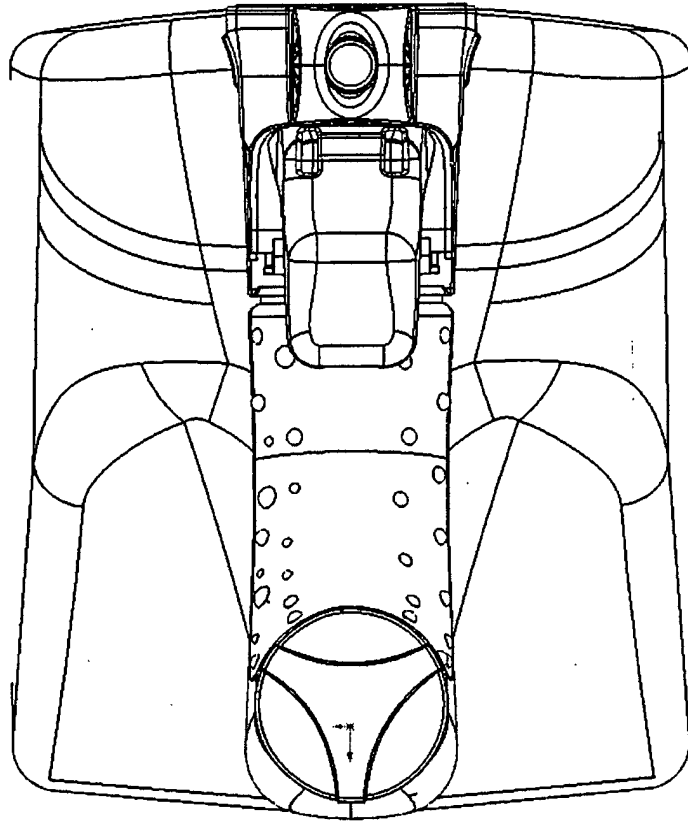

Figure 12

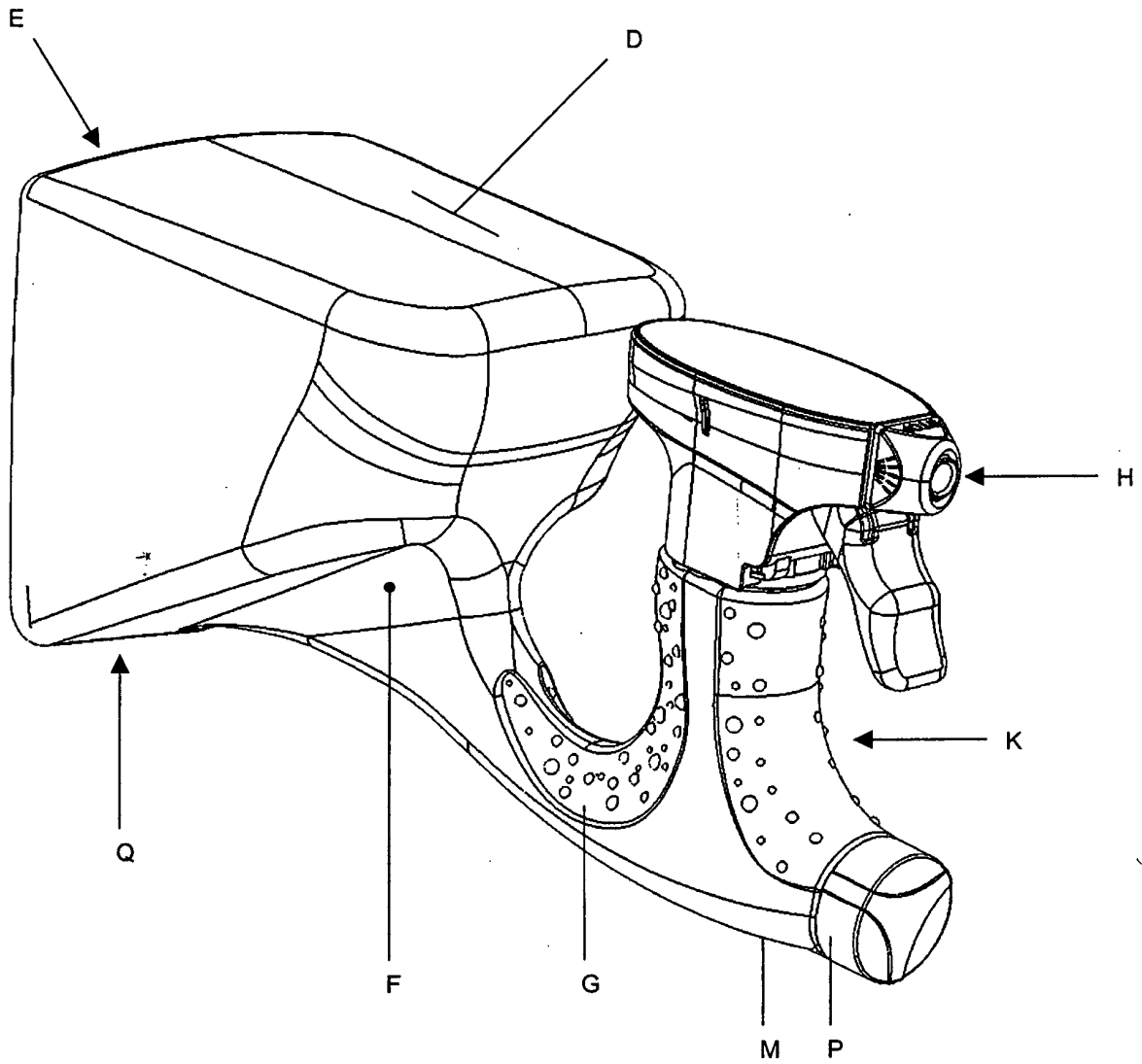

Figure 13

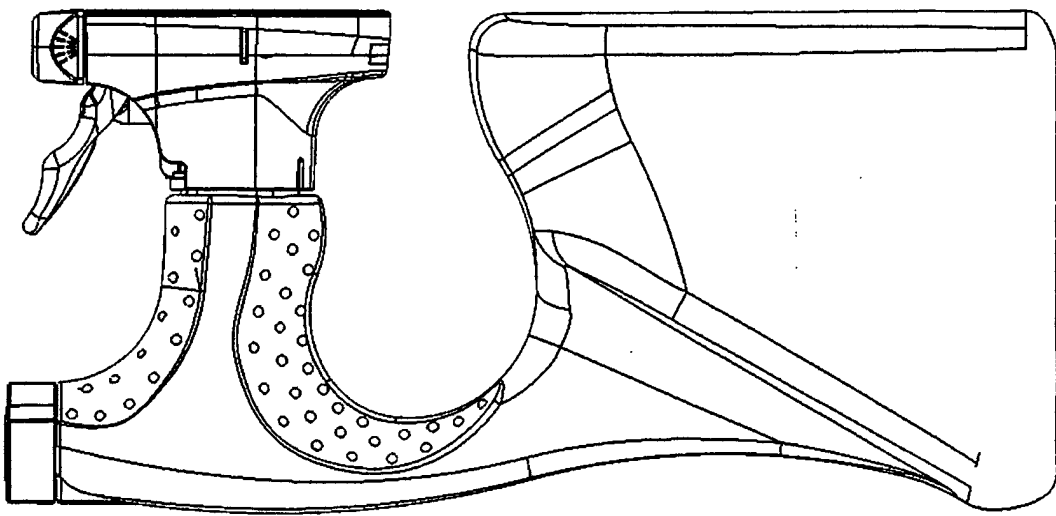

Figure 14

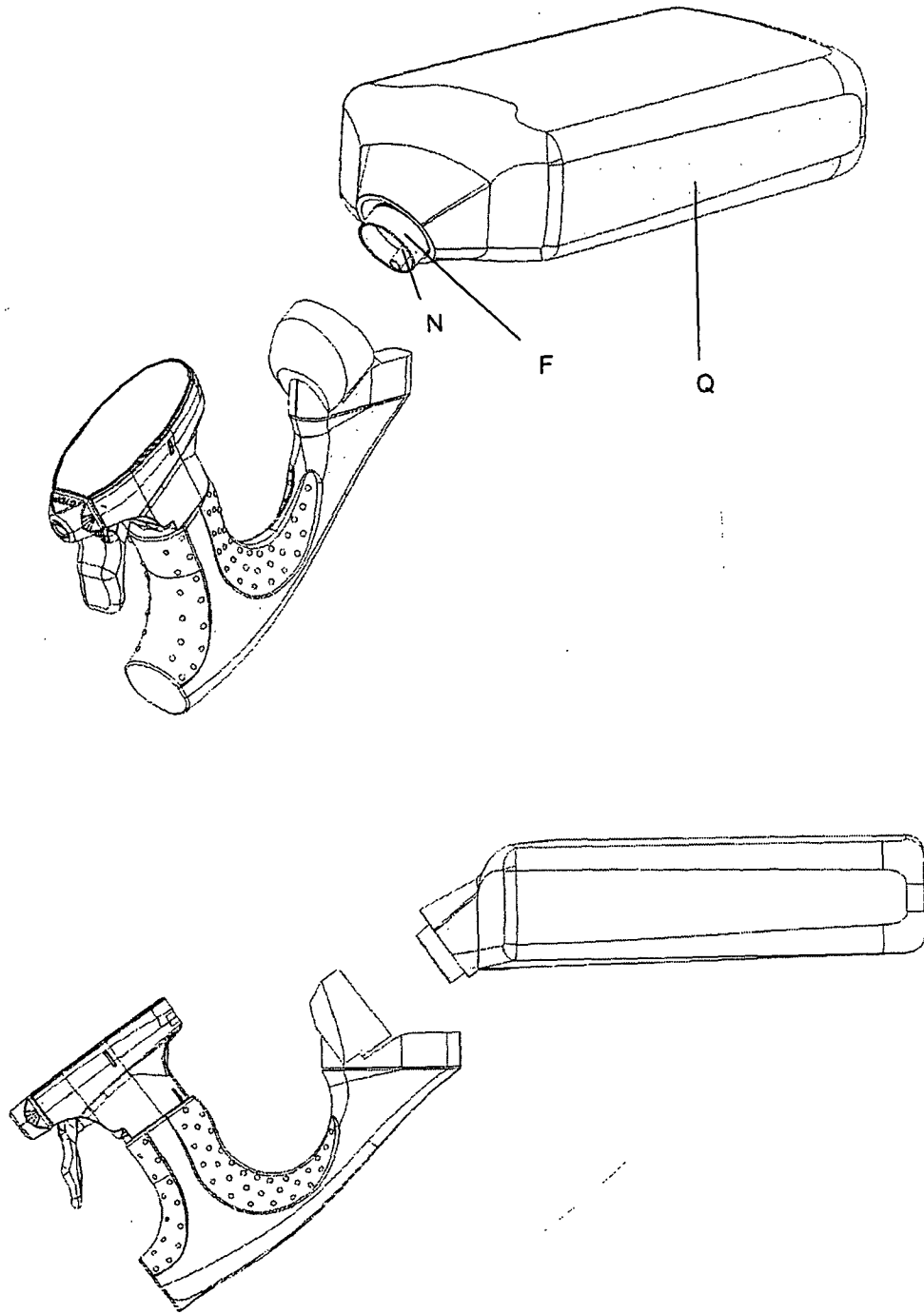

Figure 15

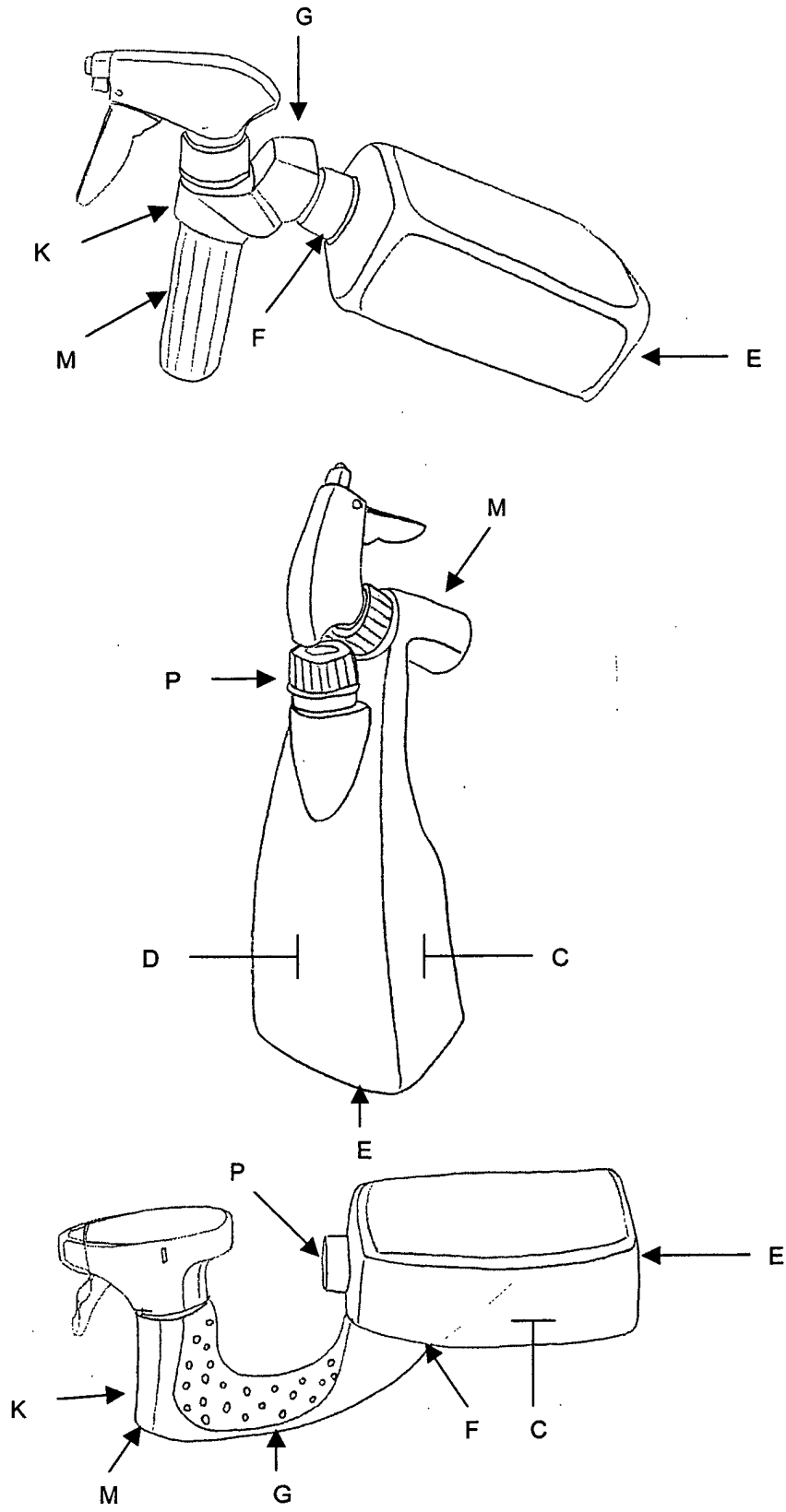

Figure 16

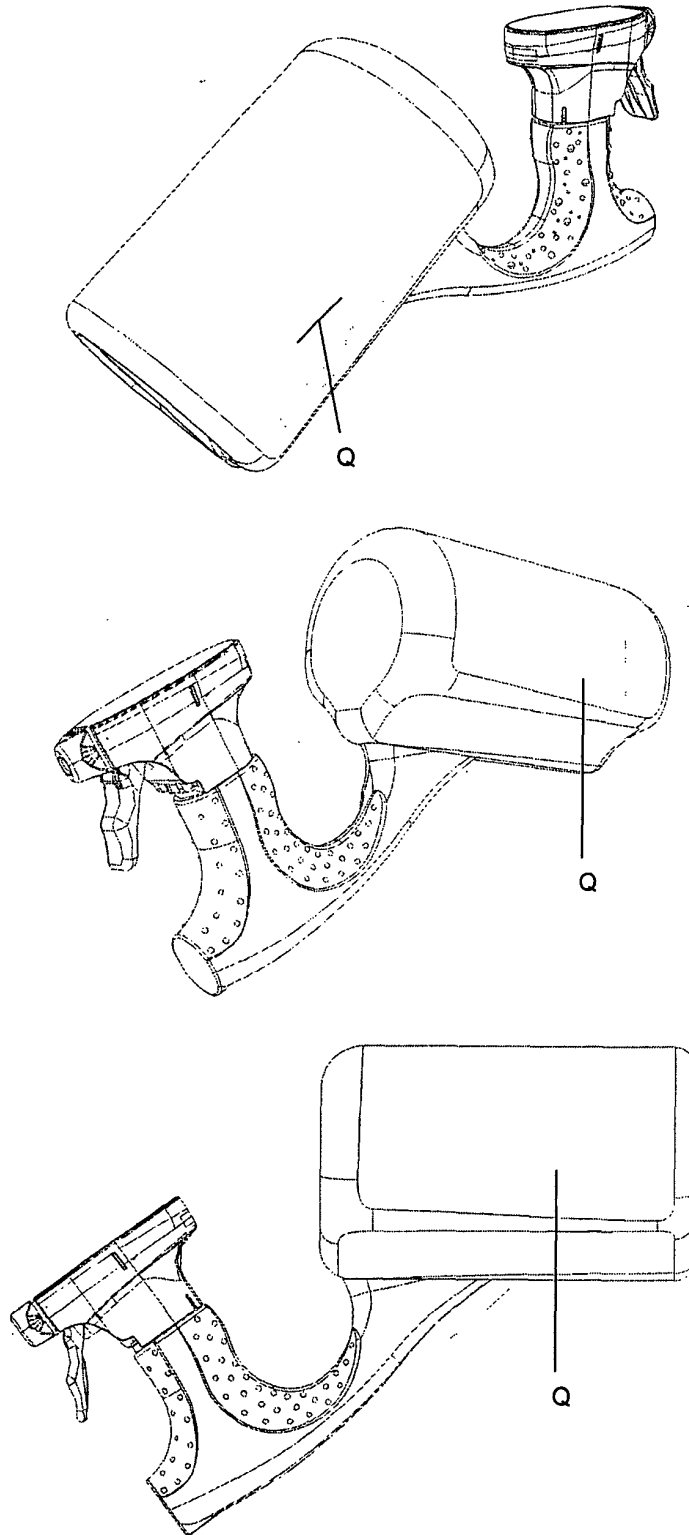

Figure 17

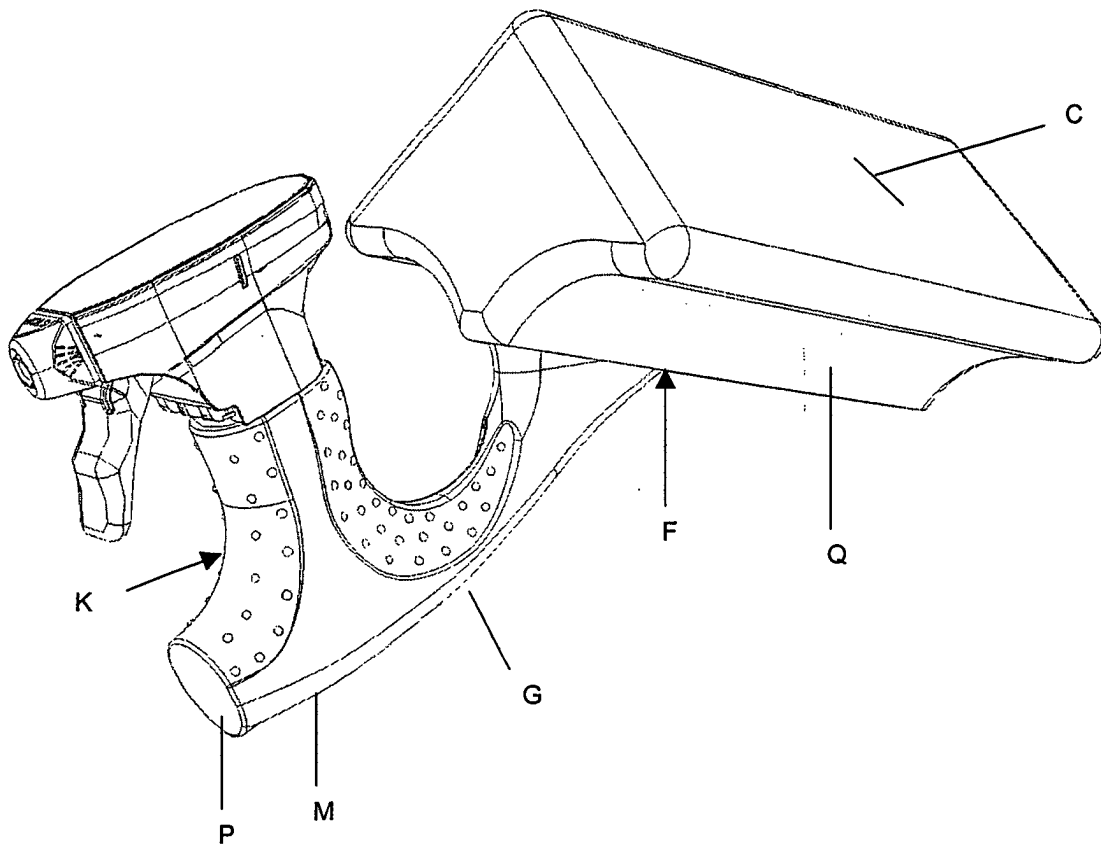

Figure 18

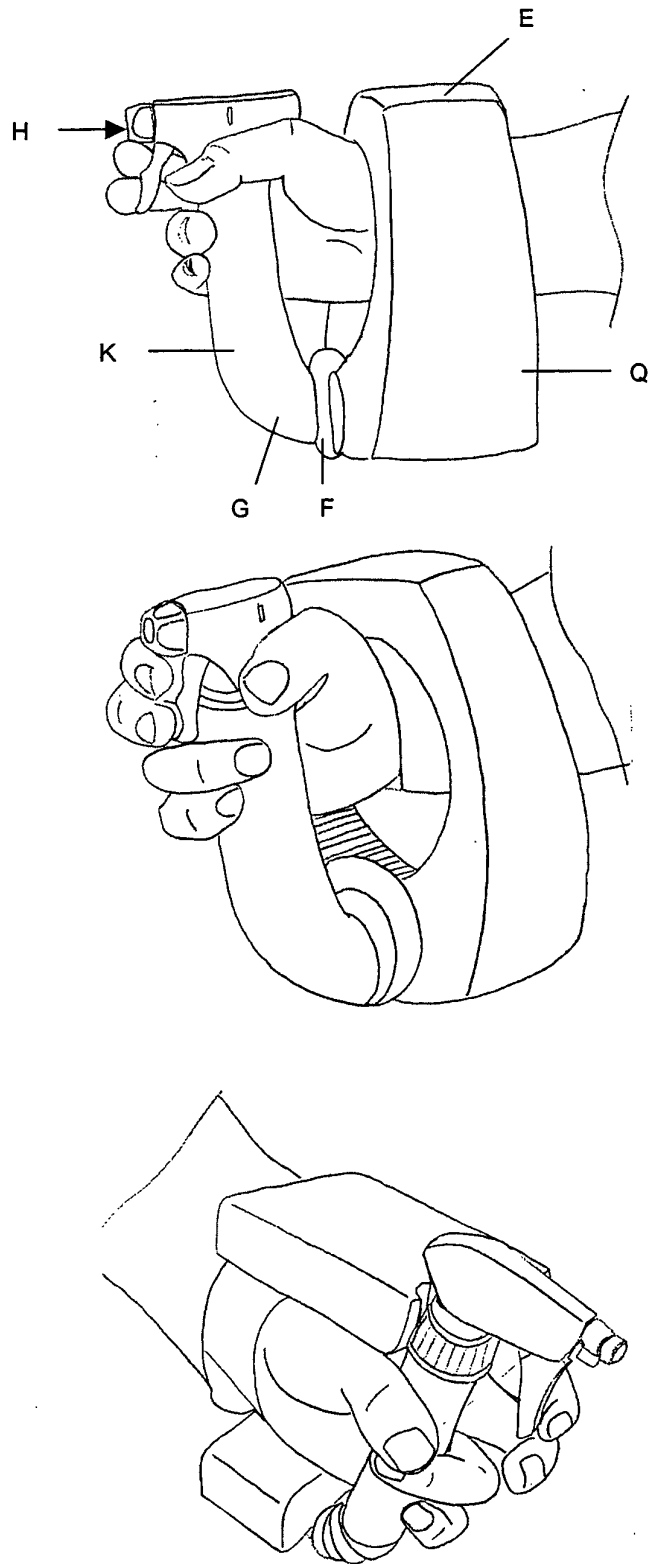

Figure 19



European Patent Office

EUROPEAN SEARCH REPORT

Application Number
EP 02 02 2655

| DOCUMENTS CONSIDERED TO BE RELEVANT | | | |
|---|---|--|--|
| Category | Citation of document with indication, where appropriate, of relevant passages | Relevant to claim | CLASSIFICATION OF THE APPLICATION (Int.Cl.7) |
| X | DE 202 01 532 U (BEISERT, HEINZ, 45665 RECKLINGHAUSEN, DE) 18 April 2002 (2002-04-18) * abstract * * figures 1-4 * | 1-13 | B05B11/00 |
| X | FR 2 711 395 A (TOBELEM FRANCIS ET CAPY GILBERT) 28 April 1995 (1995-04-28) * page 2, line 37 - page 2, line 39 * * claims 2,3 * * figures 2,3 * | 1-3,8,9, 11-13 | |
| | | | TECHNICAL FIELDS SEARCHED (Int.Cl.7) |
| | | | B05B B65D |
| The present search report has been drawn up for all claims | | | |
| Place of search THE HAGUE | | Date of completion of the search 6 February 2003 | Examiner Roldán, J |
| CATEGORY OF CITED DOCUMENTS X : particularly relevant if taken alone Y : particularly relevant if combined with another document of the same category A : technological background O : non-written disclosure P : intermediate document | | T : theory or principle underlying the invention E : earlier patent document, but published on, or after the filing date D : document cited in the application L : document cited for other reasons & : member of the same patent family, corresponding document | |

EPO FORM 1603 03 02 (P04001)

**ANNEX TO THE EUROPEAN SEARCH REPORT
ON EUROPEAN PATENT APPLICATION NO.**

EP 02 02 2655

This annex lists the patent family members relating to the patent documents cited in the above-mentioned European search report. The members are as contained in the European Patent Office EDP file on
The European Patent Office is in no way liable for these particulars which are merely given for the purpose of information.

06-02-2003

| Patent document cited in search report | | Publication date | Patent family member(s) | Publication date |
|--|---|------------------|-------------------------|------------------|
| DE 20201532 | U | 18-04-2002 | DE 20201532 U1 | 18-04-2002 |
| FR 2711305 | A | 28-04-1995 | FR 2711305 A1 | 28-04-1995 |

EPC FORM P0489

For more details about this annex : see Official Journal of the European Patent Office, No. 12/82