



Europäisches Patentamt  
 European Patent Office  
 Office européen des brevets



(11) **EP 1 416 105 A1**

(12) **EUROPEAN PATENT APPLICATION**

(43) Date of publication:  
**06.05.2004 Bulletin 2004/19**

(51) Int Cl.7: **E04F 15/20**

(21) Application number: **03078684.2**

(22) Date of filing: **29.10.2003**

(84) Designated Contracting States:  
**AT BE BG CH CY CZ DE DK EE ES FI FR GB GR  
 HU IE IT LI LU MC NL PT RO SE SI SK TR**  
 Designated Extension States:  
**AL LT LV MK**

(72) Inventors:  
 • **Van den Brand, Gerrit  
 7534 CZ Enschede (NL)**  
 • **Bosgoed, Henricus Wilhelmus Frederikus  
 7433 CX Schalkhaar (NL)**

(30) Priority: **01.11.2002 NL 1021809**

(74) Representative: **Lips, Hendrik Jan George, Ir.  
 HAAGSCH OCTROOIBUREAU  
 Breitnerlaan 146  
 2596 HG Den Haag (NL)**

(71) Applicant: **Unifloor B.V.  
 7418 EV Deventer (NL)**

(54) **Sound-insulating subfloor for all floorings, including ceramic floor elements**

(57) The invention relates to a subfloor for flooring elements consisting of an assembly comprising a lower plate and a top plate, in which lower and top plate have been manufactured from different materials and the assembly has sufficient sound insulating properties for

muffling impact sound and also has sufficient supporting power to carry the heaviest floorings such as e.g. ceramic floor elements or floor elements of natural stone. Further, an embodiment is provided which allows for incorporating electricity lines, water pipes, heating pipes and corresponding pipes.

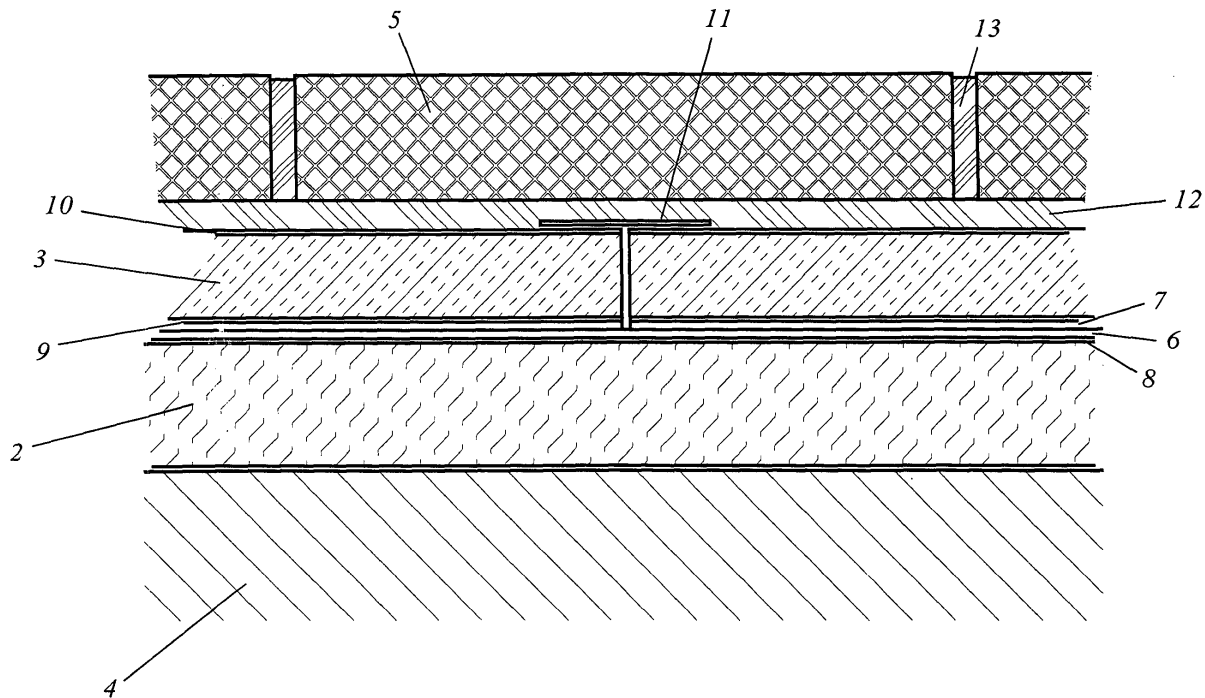

FIG. 2

EP 1 416 105 A1

## Description

**[0001]** The present invention relates to a subfloor or covering floor for a flooring or flooring elements consisting of an assembly comprising at least a lower plate and a top plate, in which the plates are, or have been, glued to one another, or otherwise.

**[0002]** Such assembled subfloors are known per se and serve for levelling the substrate on which they are applied on one hand, and for achieving a sufficiently high sound insulation on the other, which mainly concerns muffling of impact sound. When these subfloors are used together with regular floor covering and even with parquet, one can achieve conclusive results to remain within the old standards in relation to impact sound in house-construction.

**[0003]** However, with these known subfloors it is by no means possible to be able to meet the new sound standards stated in the Building Order, or the standard experienced as being desirable in practice. In practice, this means that an impact sound reduction of 10 dB, measured according to the present standard, should be achieved.

**[0004]** Thus, the object of the invention is to provide a subfloor by which said impact sound reduction can be realized. A further object is to provide a subfloor which is suitable for all types of flooring and which can realize the impact sound reduction when combined with said flooring as well. Said floorings include floorings which are difficult to apply such as ceramic floor elements or floor elements of natural stone.

**[0005]** Accordingly, according to the present invention it is provided for that the assembly is designed in such a way that an impact sound reduction of at least 10 dB, according to NEN-ISO 140-8/717-2 ( $\Delta L_{lin}$ ) is realized and that the assembly is suitable for mounting all types of flooring on it including ceramic flooring elements or flooring elements of natural stone.

**[0006]** According to a first embodiment, to that end it is provided for, that the upper plate is manufactured from a foam material with a reinforcing layer of glass fibre being applied on at least one side thereof.

**[0007]** With these features, in which the foam material is e.g. an extruded foam material, such as hard polystyrene, for example, one obtains a top plate which - from a certain thickness - has sufficiently sound-insulating properties for fulfilling the stated standard combined with a subfloor plate. Furthermore, this top plate is stiff enough to form a plane supporting base for all types of flooring and is at the same time strong enough to be able to carry the heaviest coverings, ceramic or natural stone floor elements in particular. Combined with a levelling lower plate, a completely plane floor with ceramic or natural stone floor elements or floor elements of natural stone can be realized.

**[0008]** The reinforcing layer of glass fibre further provides a proper plane of adhesion for fitting any type of desired flooring including ceramic or natural stone floor

elements onto said top plate.

**[0009]** For further improving these properties and for preventing the glass fibre from possibly getting attacked by more aggressively acting adhesion agents, according to another embodiment it is provided for that the glass fibre is provided with a layer of cement-bonded egaline on the top side of the plate.

**[0010]** Further, it is important that the top plates can be properly connected to one another along their abutting edges. According to the invention, to that end, a fabric tape is provided which in longitudinal direction across the lines of contact or joints will be applied between abutting top plates. Preferably, this a self-adhesive glass fibre tape that can be applied in one operational run.

**[0011]** The lower plate is preferably assembled from another material than the top plate in which the transition between the various materials contributes to the suppression of impact sound. Preferably, it is provided for that the lower plate substantially comprises a resilient wood fibre board.

**[0012]** According to a second embodiment, it is provided for that the top plate comprises a cement-bonded fibre board. Such a top plate has the advantage that it presents a structurally extremely stiff subfloor having a large load bearing capacity. Such a subfloor is particularly suitable for fitting ceramic or natural stone floor elements on it.

**[0013]** As lower plate, likewise at least one plate of another material is employed such as a plate of wood fibre material, preferably a plate having resilient properties such as soft board, for example. The big difference in specific density of such a lower plate in comparison with a cement-bonded top plate contributes to the fact that very good sound insulating properties can be realized with the assembly of this lower and top plate.

**[0014]** The sound insulating properties can be improved further by applying a layer composed of a latex-bonded mixture of coconut and wood fibres onto the top plate. Important for its structure and properties is that this further layer is fixedly connected to the top plate. To that end, according to the invention it is provided for that the further layer is applied onto the top plate with glue, which glue is used simultaneously or consecutively for applying the flooring.

**[0015]** The lower plate in this embodiment likewise comprises a resilient wood fibre board. According to a further development it is provided for that the lower plate consists of a first and a second soft and/of resilient wood fibre board, in which the first wood fibre board, the lower wood fibre board, is intended for receiving piping systems. Thus, the subfloor will have a larger thickness and is therefore intended especially for being employed as covering floor in houses under construction, in which the thickness of the covering floor has been taken into account in advance.

**[0016]** Ducts for lines such as e.g. power cables, water pipes and heating pipes, can be milled in the first

wood fibre board. According to a further development, it can also be provided for that said first wood fibre board, the lower wood fibre board, consists of various dimensioned parts, in such a way that consecutive dimensioned parts together can form a continuous piping slot. By employing fixed dimensions, a normalization for making ducts can be established, so that they are always fitted on the same location. This offers great advantages over the present method in which one more or less chooses the shortest way for the ducts and/or the ducts are situated partly in a poured concrete supporting floor.

**[0017]** With such a covering floor, it is preferably provided for, that at least the top plates are provided with a groove and tongue system for mutual engagement of the subsequent parts of the subfloor. Using such a system, the covering floor can be laid quickly, in which a proper connection of the plates is guaranteed. The latter is important for both forming a plane, stiff floor and for the sound insulating properties.

**[0018]** Further, for stabilisation and sound insulation in all embodiments it is essential that the lower and top plates can be intimately connected to one another. This can be realized effectively by mutually glueing the plates. According to a further development of the invention it can be provided for, that a glue component is applied to the bottom side of the top plate, which glue component is intended to establish a glue connection with a complementary glue component applied to the top side of the lower plate. Then, according to a further development, the lower plate is provided with a paper layer, namely a paper layer having the important property of engaging a fibre structure particularly well.

**[0019]** Preferably, the glue components have the property that they mutually provide for a particularly well adhesion but that they will not, or only hardly, adhere to other surfaces. As a result of this property a subfloor system is achieved which can be processed easily and in which an excellent mutual adherence between the plates can be established.

**[0020]** Further, when using ceramic or natural stone floor elements it is of utmost importance that these can be fixedly applied onto the subfloor. To this end, according to the invention a two component mortar is provided, the first component comprising a synthetic resin and the second one a cement. In order to prevent a possible movement in the subfloor, e.g. due to a local heavy load, from resulting in disengagement of one or more ceramic or natural stone floor elements, it is preferably provided for, that the first component is a dispersion of a synthetic resin and a rubber granulate and the second component is a cement, more preferably a quick cement.

**[0021]** Such a composition yields a mortar having permanent elastic properties, which furthermore adheres particularly well to the cement-bonded egaline layer applied on the glass fibre reinforcement layer on the top plate. Use of the quick cement provides for a quick setting as a result of which a laid floor can be walked on

after a relatively short time.

**[0022]** The joints between the applied ceramic or natural stone floor elements are filled with joint mortar, which is preferably a two component mortar, the first component substantially comprising a cement and the second component being a dispersion having elastic properties. Said joint mortar has greater elastic properties than the mortar for applying the floor elements as a result of which the joints are capable of, if necessary, absorbing any movement between adjacent floor elements.

**[0023]** The subfloor according to the invention is further explained by way of the example given in the drawing, in which

fig. 1 illustrates schematically laying pattern for an assembly of lower and top plates;

fig. 2 illustrates schematically a cross-section of a first embodiment of an assembly of lower and top plates;

fig. 3 illustrates schematically a cross-section of a second embodiment of an assembly of lower and top plates; and

fig. 4 illustrates a cross-section of a variation of the second embodiment of an assembly of lower and top plates.

**[0024]** Fig. 1 shows an assembly 1 of lower plates 2 and top plates 3 applied floatingly on a supporting floor 4. The plates have been laid in offset relationship in such a way that subsequent connections between plates are not aligned on any location and the connections between lower and top plates do not coincide on any location. Ceramic or natural stone floor elements 5 have been fitted on the top plates, in which one tries, as far as possible, to have the joints between floor elements not coincide with the connections between top plates 3.

**[0025]** Fig. 2 shows a cross-section of an assembly of lower plates 2 on top plates 3, with ceramic or natural stone floor elements 5 being mounted on top plates 3. In the example given, the lower plate 2, a soft wood fibre plate (softboard), is floatingly mounted on the supporting floor 4 and is intended for correction of irregularities in that floor, as well as for reduction of sound, impact sound in particular.

**[0026]** Lower plate 2 and top plate 3 are glued to one another, to which end a special adhesive layer 6, 7 has been applied on the sides concerned of said plates, which has been done with a roller or in a more automated process with a roll. The adhesive of these identical adhesive layers 6, 7 has such properties that mutual contact will yield a particularly well glueing connection, but that in case of contact with other surfaces there will be no or hardly any adhesive force.

**[0027]** In order to achieve a good adherence of the adhesive layer 6 on the lower plate 2, a paper layer 8 is applied on said lower plate 2, which is preferably composed of a resilient fibre material.

**[0028]** Top layer 3 comprises substantially a foam material, which is preferably an extruded hard polystyrene, which is particularly suitable for supporting the ceramic or natural stone floor elements 5. For reinforcing said layer, additionally, a reinforcing layer 9, 10 is applied on both sides, preferably comprising a glass fibre layer. In order to have the reinforcing layer at the top side of top plate 3 form an entity together with upper reinforcing layers of the further top plates, glass fibre strips 11 have been applied across the joints between the adjacent top plates. Preferably, self-adhesive glass fibre strips 11 are applied.

**[0029]** A mortar layer 12 having somewhat resilient characteristics is applied on the mutually connected top plates 3, through which layer the ceramic or natural stone floor elements 5 are fixedly connected to the sub-floor. For jointing the ceramic or natural stone floor elements 5 one uses a special joint mortar 13 which is likewise slightly resilient, but which need not have the specific properties of said mortar 12.

**[0030]** Sound reduction with such an assembly of plates with a lower soft wood fibre board having a thickness of 15 mm, a top, polystyrene plate, commercially available under the designation XPS, having a thickness of 10 mm and applied thereon ceramic tiles of 30x30 cm, as measured by TNO, is according to the old standard NEN 140-8 and the new standard NEN-EN-ISO 717-2, respectively:

$$\text{minimally } \Delta I_{\text{co-lab}} = 10 \text{ dB}$$

$$\text{minimally } \Delta L_{\text{lin}} = 10 \text{ dB}$$

**[0031]** With this assembly, the required standard is already met at a relatively small thickness, the assembly furthermore being suitable for supporting the most heavy types of floorings.

**[0032]** Fig. 3 shows an example of the second embodiment in which the polystyrene plate has been substituted by a cement-bonded wood fibre board 14, a cement-bonded chipboard, for example. The same reference numbers have been used for the further constituent parts corresponding to those in the example of fig. 1. The wood fibre board 14 has a much higher specific density than the lower layer 2. Also due to the strongly differing properties, this assembly provides for a very effective sound reduction and is furthermore particularly suitable for supporting the heaviest floorings, including ceramic or natural stone floor elements. Sound reduction for the assembly of lower and top plates 2, 14, respectively of 15 mm and 10 mm thickness, with a covering of ceramic tiles of 30x30 cm, as measured by TNO, is according to the old standard NEN 140-8 and the new standard NEN-EN-ISO 717-2, respectively:

$$\Delta I_{\text{co-lab}} = 11 \text{ dB}$$

$$\Delta L_{\text{lin}} = 11 \text{ dB}$$

**[0033]** An additional sound-reducing mat 16 of latex-bonded coconut and wood fibres has been applied on the top plate 14. This mat 16 is fitted in the mortar, tile glue 12 is applied on cement-bonded plate 14. Sound reduction for the assembly of lower and top plates 2, 14, respectively of 15 mm and 10 mm thickness, mat 16 having a thickness of 4 mm, glue not included, and a covering of ceramic tiles of 30x30 cm, as measured by TNO, is according to the old standard NEN 140-8 and the new standard NEN-EN-ISO 717-2, respectively:

$$\Delta I_{\text{co-lab}} = 13 \text{ dB}$$

$$\Delta L_{\text{lin}} = 12 \text{ dB}$$

**[0034]** Fig. 4 shows a further variation in which a further plate 17 of a soft and/or resilient fibre material, e.g. softboard, has been applied underneath said assembly of fibre board 2 and cement-bonded wood fibre board 14. In this variation, the plates 2 and 14 are preferably glued to one another in advance, and further a groove 19 and tongue 18 system has been provided by which the consecutive assembled plates 2, 14 can engage one another. Further finishing is similar to the finishing shown in fig. 3, by way of example.

**[0035]** Further plate 17 is provided with slots 20, which can be made by milling them from plate 17 or by spacing certain plates 17 so that a continuous slot arises between them. It is also possible to provide a certain part of the plates 17 with a slot beforehand or the plates 17 can be supplied in various dimensions. The slots are made in such a way, that continuous slots are always at a predetermined distance from a wall. The slots 20 are intended for receiving pipes 21, 22 such as e.g. water pipes, ducts of a heating system, electricity wires and the like.

**[0036]** Sound reduction for the assembly of lower and top plates 2, 14, having a total thickness of 30 mm and a further plate 17 having a thickness of 30 mm, thus a total thickness of 60 mm, without any further covering, as measured by TNO, is according to the old standard NEN 140-8 and the new standard NEN-EN-ISO 717-2, respectively:

$$\Delta I_{\text{co-lab}} = 16 \text{ dB}$$

$$\Delta L_{\text{lin}} = 15 \text{ dB}$$

[0037] The measurements were carried out with slots having a length of 2 metres per square metre of floor surface, with pipes mounted in the slots.

[0038] With a thus assembled subfloor a particularly large sound reduction can be realized through which also possible future standards can be met. Furthermore this subfloor is suitable for all types of floorings, thus also for heavy coverings with ceramic or natural stone floor elements. Due to the total thickness of the subfloor it is particularly suitable for being employed in houses under construction, where this thickness has already been taken into account. The possibility of incorporating pipe systems in the subfloor allows for that a specific part of the construction work can be carried out much more efficiently. Furthermore, this construction method produces a much more clearly structured piping system.

### Claims

1. Subfloor or covering floor for a flooring or flooring elements consisting of an assembly comprising at least a lower plate and a top plate, in which the plates are, or have been, glued to one another, or otherwise, **characterized in that** the assembly is designed in such a way that an impact sound reduction of at least 10 dB is realized and that the assembly is suitable for applying all types of flooring on it including ceramic floor elements or floor elements of natural stone.
2. Subfloor according to claim 1, **characterized in that** the top plate is made of a foam material with a reinforcing layer of glass fibre being applied on at least one side thereof.
3. Subfloor according to claim 2, **characterized in that** the foam material is an extruded foam material, such as polystyrene, for example.
4. Subfloor according to claims 2-3, **characterized in that** the glass fibre on the top side of the plate is provided with a layer of cement-bonded egaline.
5. Subfloor according to claim 1, **characterized in that** the top plate comprises a cement-bonded fibre board.
6. Subfloor according to claim 5, **characterized in that** a further layer composed of a latex-bonded mixture of coconut and wood fibres is applied onto the top plate.
7. Subfloor according to claim 6, **characterized in that** the further layer is mounted on the top plate with glue, which glue can also be used for fitting the flooring.
8. Subfloor according to claims 1-7, **characterized in that** the lower layer is substantially composed of another material than the top plate.
9. Subfloor according to claim 8, **characterized in that** it comprises at least one wood fibre board and more preferably at least one resilient wood fibre board.
10. Subfloor according to claim 9, **characterized in that** the lower plate comprises a first and a second wood fibre board, in which the first wood fibre board, the lowermost wood fibre board is intended to incorporate piping systems.
11. Subfloor according to claim 10, **characterized in that** said first wood fibre board, the lower wood fibre board, consists of various dimensioned parts, in such a way that consecutive dimensioned parts together can form a continuous piping slot.
12. Subfloor according to claims 5-11, **characterized in that** at least the top plates are provided with a groove and tongue system for mutual engagement of the subsequent parts of the subfloor.
13. Subfloor according one or more of the claims 8-12, **characterized in that** with a lower plate to be glued, a paper layer is applied on the side to be glued of said lower plate.
14. Subfloor according to claims 1-13, **characterized in that** a glue component is applied to the bottom side of the top plate, which glue component is intended to establish a glue connection with a complementary glue component, applied on the top side of the lower plate.
15. Edge strip to be used together with a subfloor according to one or more of the preceding claims 1-14, **characterized in that** this is a strip composed of a foam material having an open or closed cell structure.
16. Connecting means for a subfloor according to claims 2-4, **characterized in that** adjacent top plates are connected to one another by means of a fibre tape.
17. Connecting means according to claim 16, **characterized in that** the fibre tape is a self-adhesive glass fibre tape.
18. Mortar to be used for applying ceramic flooring elements or flooring elements of natural stone onto a subfloor according to one of the claims 1-17, **characterized in that** this is a single component or two component mortar with a first component compris-

ing a synthetic resin and the second one a quick cement.

19. Mortar according to claim 13, **characterized in that** the first component is a dispersion of a synthetic resin and a rubber granulate and the second component is a cement, more preferably a quick cement. 5
20. Joint mortar to be used for joining ceramic flooring elements or flooring elements of natural stone on a subfloor according to claims 1-17, **characterized in that** this mortar is a single component or a two component mortar, the first component substantially comprising a cement and the second component being a dispersion having elastic properties. 10  
15

20

25

30

35

40

45

50

55

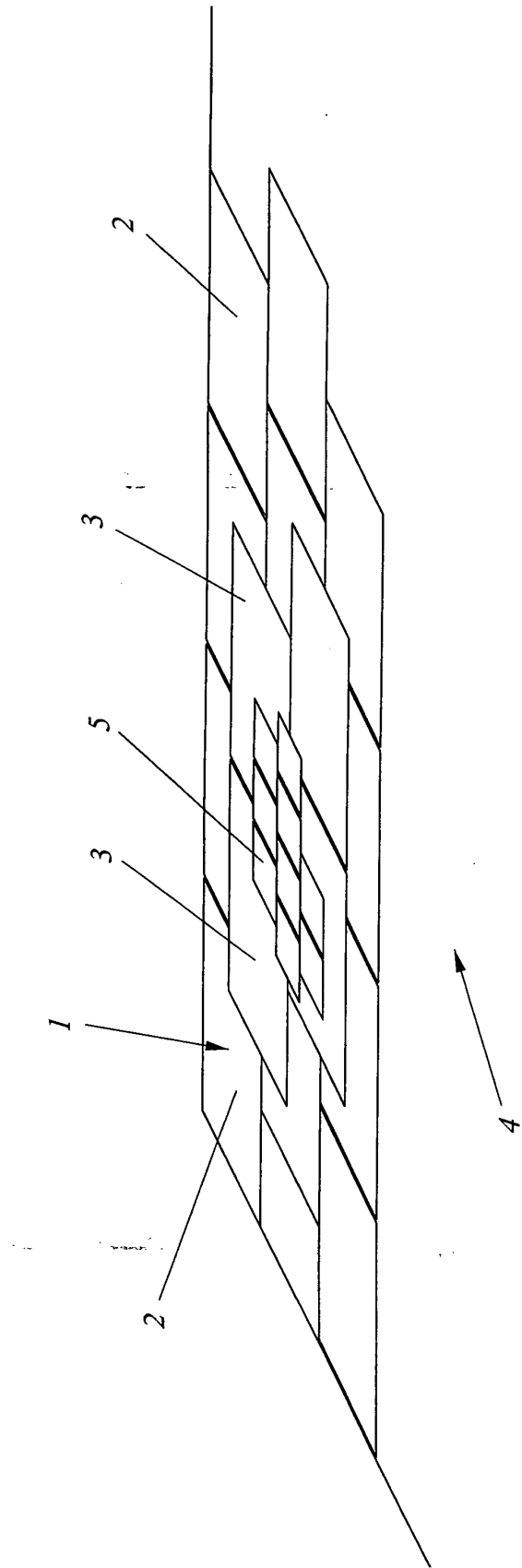

FIG. 1

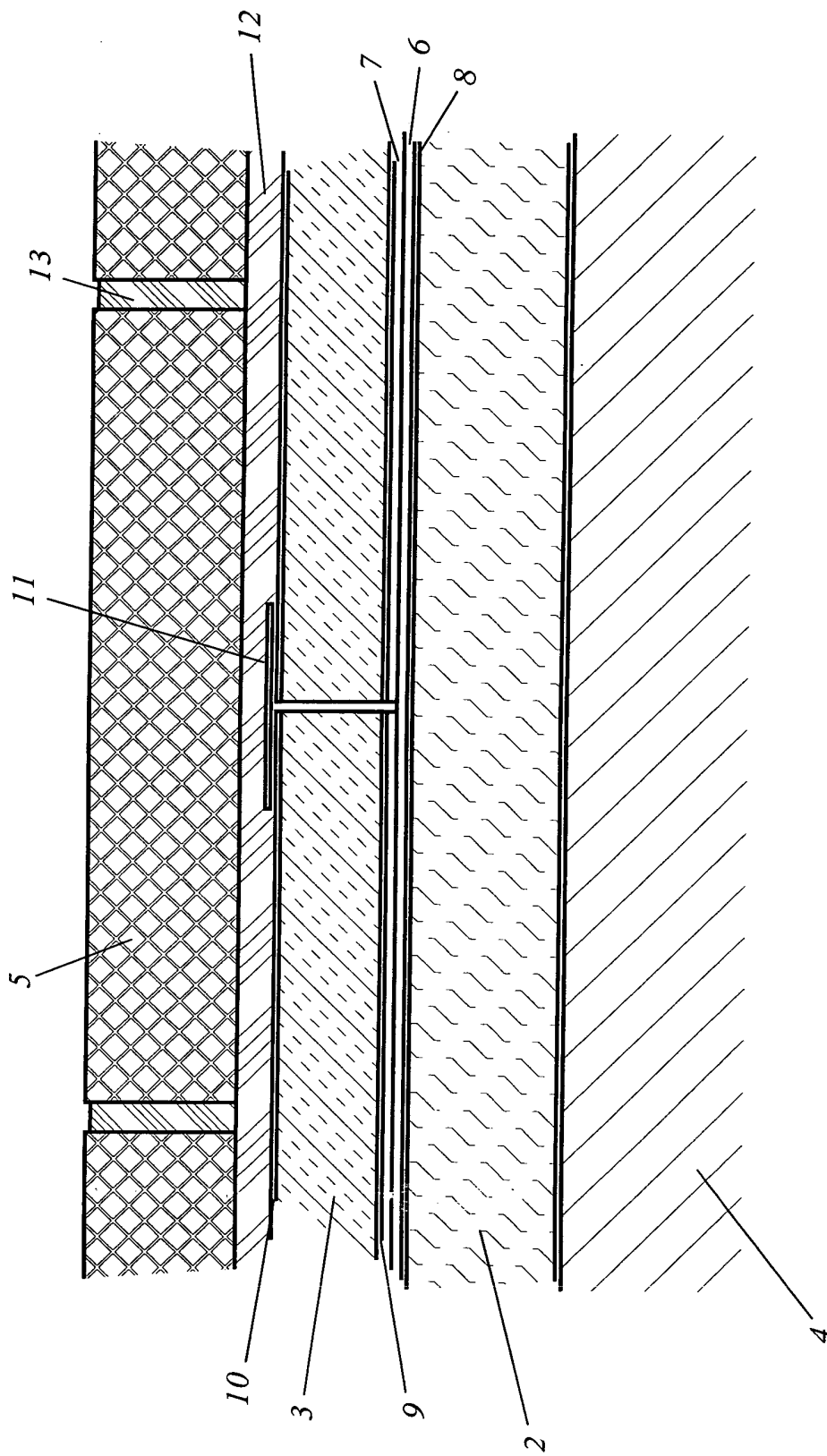

FIG. 2

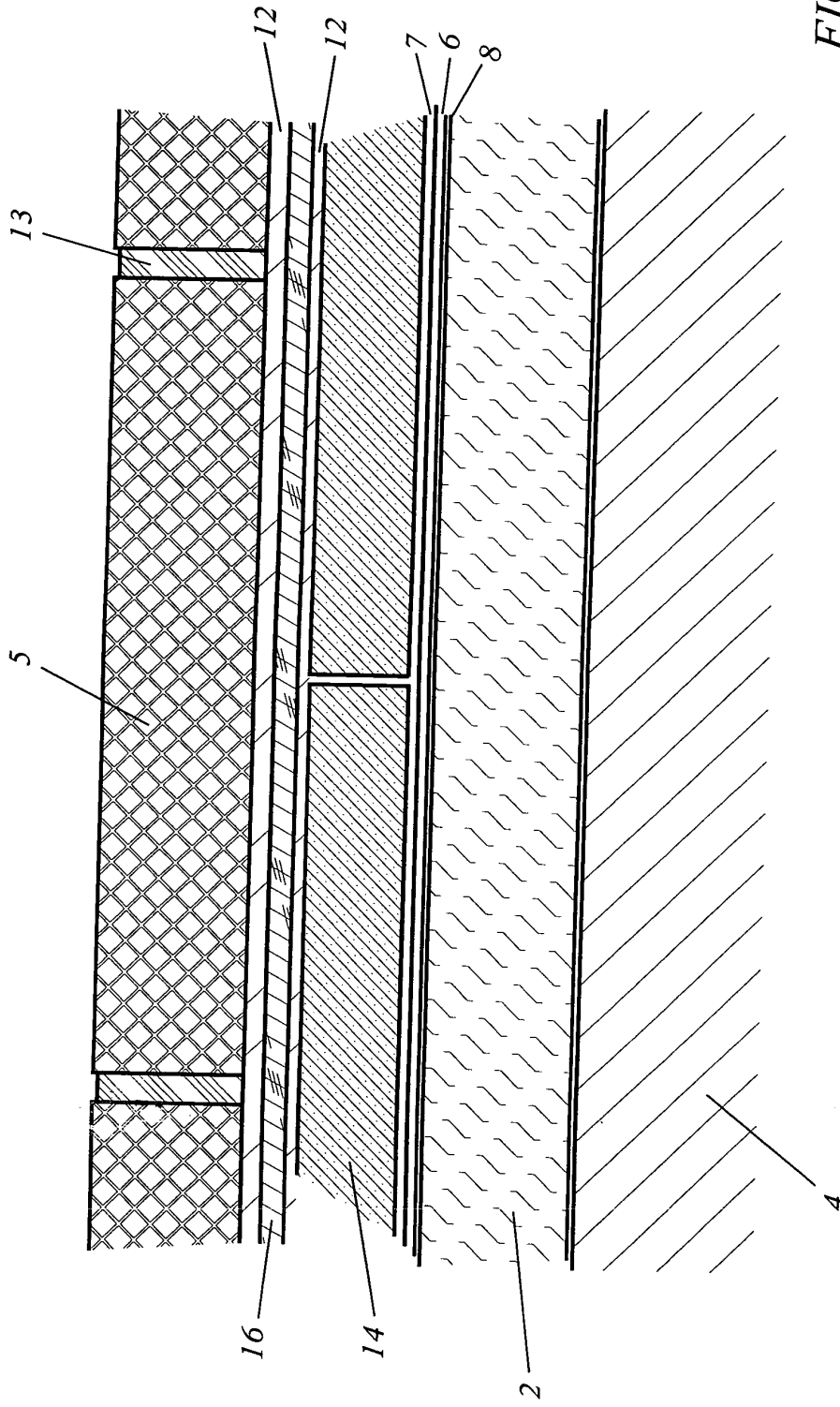

FIG. 3

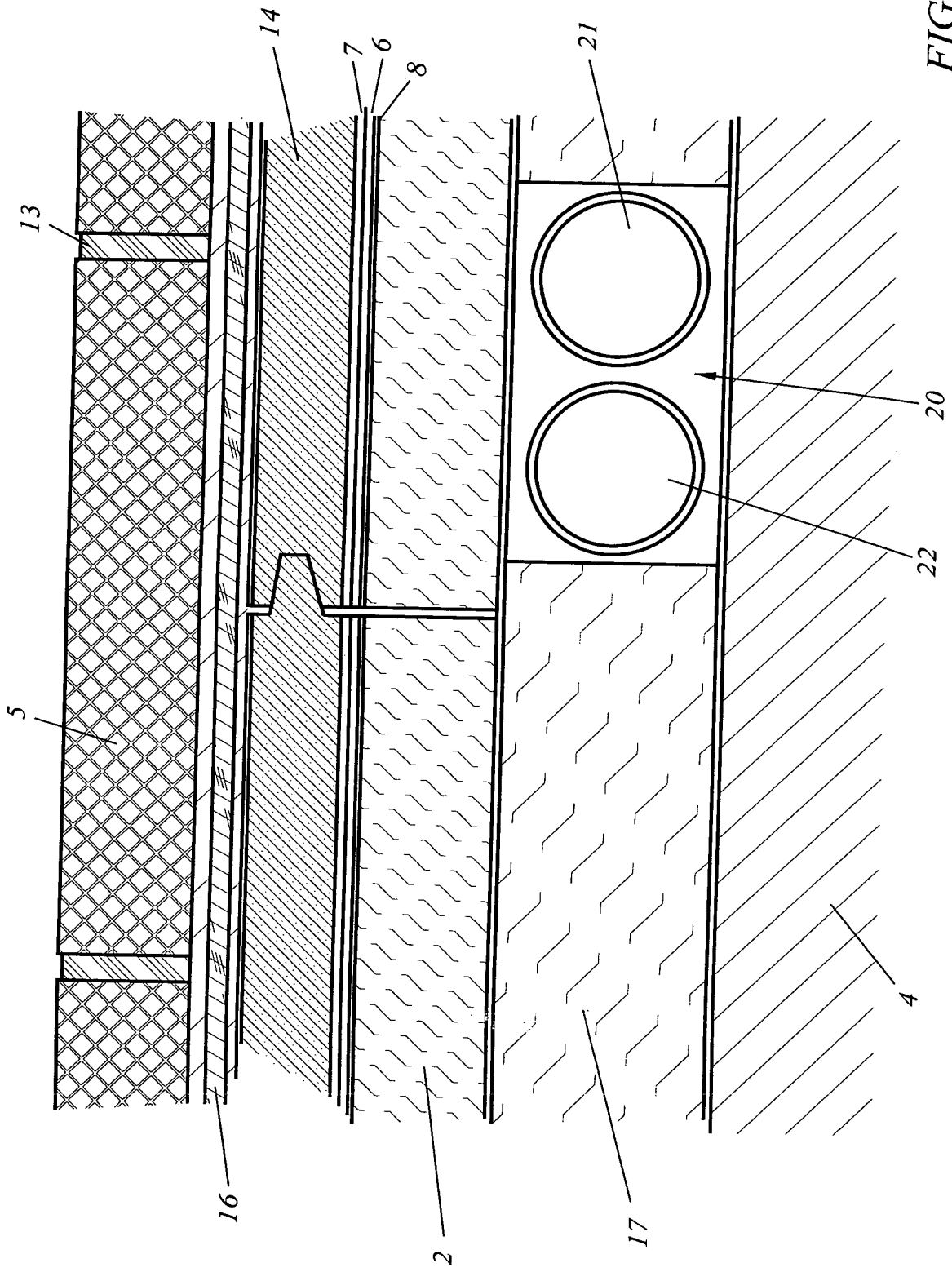

FIG. 4



European Patent  
Office

EUROPEAN SEARCH REPORT

Application Number  
EP 03 07 8684

DOCUMENTS CONSIDERED TO BE RELEVANT			
Category	Citation of document with indication, where appropriate, of relevant passages	Relevant to claim	CLASSIFICATION OF THE APPLICATION (Int.Cl.7)
X	EP 0 421 849 A (TOMECANIC SA) 10 April 1991 (1991-04-10) * column 2, line 56 - column 7, line 43; figures 1-4 *	1-4,8,18	E04F15/20
Y		5,15	
A		16,17, 19,20	
X	US 5 187 905 A (POURTAU THIERRY E ET AL) 23 February 1993 (1993-02-23) * column 1, line 39 - column 6, line 61; figures 1,2 *	1-3,14, 18,20	
A		4	
X	EP 0 904 932 A (KABUSHIKIKAISHA EDAGUMI) 31 March 1999 (1999-03-31) * page 4, line 56 - page 10, line 14; figures 1-8 *	1,14	
Y		3,8-10	
Y	EP 0 461 328 A (TINE HOLDING S A) 18 December 1991 (1991-12-18) * page 3, line 44 - page 7, line 33; figures 1-10 *	3,5	TECHNICAL FIELDS SEARCHED (Int.Cl.7)
A		1,2,6,8, 9,12	E04F
Y	DE 199 16 353 A (SCHWOERER HAUS GMBH & CO) 19 October 2000 (2000-10-19) * column 2, line 42 - column 3, line 68; figures 1-4 *	8-10	
A		1,11	
	--- -/--		
The present search report has been drawn up for all claims			
Place of search	Date of completion of the search	Examiner	
THE HAGUE	6 February 2004	Ayiter, J	
CATEGORY OF CITED DOCUMENTS		T : theory or principle underlying the invention E : earlier patent document, but published on, or after the filing date D : document cited in the application L : document cited for other reasons & : member of the same patent family, corresponding document	
X : particularly relevant if taken alone Y : particularly relevant if combined with another document of the same category A : technological background O : non-written disclosure P : intermediate document			

EPO FORM 1503 03/92 (P04C01)



European Patent  
Office

EUROPEAN SEARCH REPORT

Application Number  
EP 03 07 8684

DOCUMENTS CONSIDERED TO BE RELEVANT			
Category	Citation of document with indication, where appropriate, of relevant passages	Relevant to claim	CLASSIFICATION OF THE APPLICATION (Int.CI.7)
Y	FR 2 372 942 A (BAT APPLIC REVETEMENTS PLASTIQ) 30 June 1978 (1978-06-30) * page 2, line 14 - line 18 * * page 3, line 16 - page 4, line 38; figures 1-3 *	15	
A	---	1-3,14, 20	
A	US 3 902 293 A (BREAULT HOMER ET AL) 2 September 1975 (1975-09-02) * column 3, line 33 - column 8, line 16; figures 1-10 * -----	1,5, 8-10,12	
			TECHNICAL FIELDS SEARCHED (Int.CI.7)
The present search report has been drawn up for all claims			
Place of search <b>THE HAGUE</b>		Date of completion of the search <b>6 February 2004</b>	Examiner <b>Ayiter, J</b>
CATEGORY OF CITED DOCUMENTS		T : theory or principle underlying the invention E : earlier patent document, but published on, or after the filing date D : document cited in the application L : document cited for other reasons ----- & : member of the same patent family, corresponding document	
X : particularly relevant if taken alone Y : particularly relevant if combined with another document of the same category A : technological background O : non-written disclosure P : intermediate document			

EPO FORM 1609 03 82 (P04C01)

ANNEX TO THE EUROPEAN SEARCH REPORT  
ON EUROPEAN PATENT APPLICATION NO.

EP 03 07 8684

This annex lists the patent family members relating to the patent documents cited in the above-mentioned European search report. The members are as contained in the European Patent Office EDP file on  
The European Patent Office is in no way liable for these particulars which are merely given for the purpose of information.

06-02-2004

Patent document cited in search report		Publication date		Patent family member(s)	Publication date
EP 0421849	A	10-04-1991	FR	2652605 A1	05-04-1991
			CA	2026611 A1	03-04-1991
			EP	0421849 A1	10-04-1991
US 5187905	A	23-02-1993	FR	2660341 A1	04-10-1991
			CA	2039235 A1	03-10-1991
			DE	69100368 D1	21-10-1993
			DE	69100368 T2	17-02-1994
			EP	0451026 A1	09-10-1991
			ES	2043443 T3	16-12-1993
			PT	97172 A	30-04-1993
EP 0904932	A	31-03-1999	JP	3180065 B2	25-06-2001
			JP	11100981 A	13-04-1999
			EP	0904932 A2	31-03-1999
			US	6212838 B1	10-04-2001
EP 0461328	A	18-12-1991	EP	0461328 A1	18-12-1991
			PT	97957 A	30-06-1993
DE 19916353	A	19-10-2000	DE	19916353 A1	19-10-2000
FR 2372942	A	30-06-1978	FR	2372942 A1	30-06-1978
US 3902293	A	02-09-1975	CA	983233 A1	10-02-1976
			DE	2405277 A1	08-08-1974
			NO	145626 B	18-01-1982
			US	3988187 A	26-10-1976