

(19)



(11)

EP 1 420 719 B9

(12)

CORRECTED EUROPEAN PATENT SPECIFICATION

Note: Bibliography reflects the latest situation

(15) Correction information:

**Corrected version no 1 (W1 B1)
Corrections, see page(s) 3**

(51) Int Cl.:

A61F 2/06 (2006.01)

(48) Corrigendum issued on:

09.05.2007 Bulletin 2007/19

(86) International application number:

PCT/US2002/017609

(45) Date of publication and mention of the grant of the patent:

24.01.2007 Bulletin 2007/04

(87) International publication number:

WO 2003/015664 (27.02.2003 Gazette 2003/09)

(21) Application number: **02737363.8**

(22) Date of filing: **05.06.2002**

(54) **Expandable medical device for delivery of beneficial agent**

Expandierbare medizinische Vorrichtung zur Abgabe eines Heilmittels

Dispositif médical expansible permettant la délivrance d'un médicament

(84) Designated Contracting States:

**AT BE CH CY DE DK ES FI FR GB GR IE IT LI LU
MC NL PT SE TR**

(72) Inventors:

- **SHANLEY, John, F.**
Redwood City, CA 94061 (US)
- **EIGLER, Neal, L.**
Pacific Palisades, CA 90272 (US)
- **PARK, Kinam**
West Lafayette, IN 47906 (US)
- **EDELMAN, Elazer, R.**
Brookline, MA 02445 (US)

(30) Priority: **20.08.2001 US 314259 P**

07.09.2001 US 948989

(43) Date of publication of application:

26.05.2004 Bulletin 2004/22

(74) Representative: **Diehl, Hermann O. Th. et al**

**Diehl & Partner
Augustenstrasse 46
80333 München (DE)**

(60) Divisional application:

**04018820.3 / 1 477 137
06006254.4 / 1 666 004
07001394.1 / 1 772 122
07001395.8 / 1 774 928**

(56) References cited:

EP-A- 1 132 058	WO-A-01/17577
WO-A-01/66036	WO-A-02/26281
WO-A-98/36784	DE-U- 20 200 220
US-A- 6 071 305	US-A1- 2002 038 145

(73) Proprietor: **Conor Medsystems, Inc.**

Menlo Park, CA 94025 (US)

EP 1 420 719 B9

Note: Within nine months from the publication of the mention of the grant of the European patent, any person may give notice to the European Patent Office of opposition to the European patent granted. Notice of opposition shall be filed in a written reasoned statement. It shall not be deemed to have been filed until the opposition fee has been paid. (Art. 99(1) European Patent Convention).

Description

BACKGROUND OF THE INVENTION

1. Field of the Invention

[0001] The present invention relates to tissue-supporting medical devices, and more particularly to expandable, non-removable devices that are implanted within a bodily lumen of a living animal or human to support the organ and maintain patency, and that can deliver a beneficial agent to the intervention site.

2. Summary of the Related Art

[0002] In the past, permanent or biodegradable devices have been developed for implantation within a body passageway to maintain patency of the passageway. These devices are typically introduced percutaneously, and transported transluminally until positioned at a desired location. These devices are then expanded either mechanically, such as by the expansion of a mandrel or balloon positioned inside the device, or expand themselves by releasing stored energy upon actuation within the body. Once expanded within the lumen, these devices, called stents, become encapsulated within the body tissue and remain a permanent implant.

[0003] Known stent designs include monofilament wire coil stents (U.S. Pat. No. 4,969,458); welded metal cages (U.S. Pat. Nos. 4,733,665 and 4,776,337); and, most prominently, thin-walled metal cylinders with axial slots formed around the circumference (U.S. Pat. Nos. 4,733,665; 4,739,762; and 4,776,337). Known construction materials for use in stents include polymers, organic fabrics and biocompatible metals, such as, stainless steel, gold, silver, tantalum, titanium, and shape memory alloys such as Nitinol.

[0004] U.S. Pat. Nos. 4,733,665; 4,739,762; and 4,776,337 disclose expandable and deformable interluminal vascular grafts in the form of thin-walled tubular members with axial slots allowing the members to be expanded radially outwardly into contact with a body passageway. After insertion, the tubular members are mechanically expanded beyond their elastic limit and thus permanently fixed within the body. U.S. Pat. No. 5,545,210 discloses a thin-walled tubular stent geometrically similar to those discussed above, but constructed of a nickel-titanium shape memory alloy ("Nitinol"), which can be permanently fixed within the body without exceeding its elastic limit. All of these stents share a critical design property: in each design, the features that undergo permanent deformation during stent expansion are prismatic, i.e., the cross sections of these features remain constant or change very gradually along their entire active length. These prismatic structures are ideally suited to providing large amounts of elastic deformation before permanent deformation commences, which in turn leads to sub-optimal device performance in important proper-

ties including stent expansion force, stent recoil, strut element stability, stent securement on delivery catheters, and radiopacity.

[0005] U.S. Pat. No. 6,241,762, which is incorporated herein by reference in its entirety, discloses a non-prismatic stent design which remedies the above mentioned performance deficiencies of previous stents. In addition, preferred embodiments of this patent provide a stent with large, non-deforming strut and link elements, which can contain holes without compromising the mechanical properties of the strut or link elements, or the device as a whole. Further, these holes may serve as large, protected reservoirs for delivering various beneficial agents to the device implantation site.

[0006] International patent application WO 98/36784 discloses a method of forming an expandable medical device comprising a plurality of elongated struts joined together to form a cylindrical expandable device. The strut is coated with two layers of a bioactive material. Alternatively, the bioactive material is disposed in an opening formed in a surface of the struts.

[0007] International patent application WO 01/66036 A1, published after the priority date of present application, discloses an expandable medical device comprising a plurality of through holes and a bioactive material disposed in the through holes, and discloses a method of delivering a solution of the bioactive material into the through holes and evaporating the solvent.

[0008] Of the many problems that may be addressed through stent-based local delivery of beneficial agents, one of the most important is restenosis. Restenosis is a major complication that can arise following vascular interventions such as angioplasty and the implantation of stents. Simply defined, restenosis is a wound healing process that reduces the vessel lumen diameter by extracellular matrix deposition and vascular smooth muscle cell proliferation, and which may ultimately result in re-narrowing or even reocclusion of the lumen. Despite the introduction of improved surgical techniques, devices and pharmaceutical agents, the overall restenosis rate is still reported in the range of 25 % to 50 % within six to twelve months after an angioplasty procedure. To treat this condition, additional revascularization procedures are frequently required, thereby increasing trauma and risk to the patient.

[0009] Some of the techniques under development to address the problem of restenosis include irradiation of the injury site and the use of conventional stents to deliver a variety of beneficial or pharmaceutical agents to the wall of the traumatized vessel. In the latter case, a conventional stent is frequently surface-coated with a beneficial agent (often a drug-impregnated polymer) and implanted at the angioplasty site. Alternatively, an external drug-impregnated polymer sheath is mounted over the stent and co-deployed in the vessel.

[0010] While acute outcomes from radiation therapies appeared promising initially, long term beneficial outcomes have been limited to reduction in restenosis oc-

curing within a previously implanted stent, so-called 'in-stent' restenosis. Radiation therapies have not been effective for preventing restenosis in *de novo* lesions. Polymer sheaths that span stent struts have also proven problematic in human clinical trials due to the danger of blocking flow to branch arteries, incomplete apposition of stent struts to arterial walls and other problems. Unacceptably high levels of MACE (Major Adverse Cardiac Events that include death, heart attack, or the need for a repeat angioplasty or coronary artery bypass surgery) have resulted in early termination of clinical trials for sheath covered stents.

[0011] Conventional stents with surface coatings of various beneficial agents, by contrast, have shown promising early results. U.S. Pat. No. 5,716,981, for example, discloses a stent that is surface-coated with a composition comprising a polymer carrier and paclitaxel (a well-known compound that is commonly used in the treatment of cancerous tumors). The patent offers detailed descriptions of methods for coating stent surfaces, such as spraying and dipping, as well as the desired character of the coating itself: it should "coat the stent smoothly and evenly" and "provide a uniform, predictable, prolonged release of the anti-angiogenic factor." Surface coatings, however, can provide little actual control over the release kinetics of beneficial agents. These coatings are necessarily very thin, typically 5 to 8 microns deep. The surface area of the stent, by comparison is very large, so that the entire volume of the beneficial agent has a very short diffusion path to discharge into the surrounding tissue.

[0012] Increasing the thickness of the surface coating has the beneficial effects of improving drug release kinetics including the ability to control drug release and to allow increased drug loading. However, the increased coating thickness results in increased overall thickness of the stent wall. This is undesirable for a number of reasons, including increased trauma to the vessel wall during implantation, reduced flow cross-section of the lumen after implantation, and increased vulnerability of the coating to mechanical failure or damage during expansion and implantation. Coating thickness is one of several factors that affect the release kinetics of the beneficial agent, and limitations on thickness thereby limit the range of release rates, durations, and the like that can be achieved.

[0013] In addition to sub-optimal release profiles, there are further problems with surface coated stents. The fixed matrix polymer carriers frequently used in the device coatings typically retain approximately 30% of the beneficial agent in the coating indefinitely. Since these beneficial agents are frequently highly cytotoxic, sub-acute and chronic problems such as chronic inflammation, late thrombosis, and late or incomplete healing of the vessel wall may occur. Additionally, the carrier polymers themselves are often highly inflammatory to the tissue of the vessel wall. On the other hand, use of bio-degradable polymer carriers on stent surfaces can result in the creation of "virtual spaces" or voids between the stent and

tissue of the vessel wall after the polymer carrier has degraded, which permits differential motion between the stent and adjacent tissue. Resulting problems include micro-abrasion and inflammation, stent drift, and failure to re-endothelialize the vessel wall.

[0014] Another significant problem is that expansion of the stent may stress the overlying polymeric coating causing the coating to plastically deform or even to rupture, which may therefore effect drug release kinetics or have other untoward effects. Further, expansion of such a coated stent in an atherosclerotic blood vessel will place circumferential shear forces on the polymeric coating, which may cause the coating to separate from the underlying stent surface. Such separation may again have untoward effects including embolization of coating fragments causing vascular obstruction.

SUMMARY OF THE INVENTION

[0015] In view of the drawbacks of the prior art, it would be advantageous to provide a stent capable of delivering a relatively large volume of a beneficial agent to a traumatized site in a vessel while avoiding the numerous problems associated with surface coatings containing beneficial agents, without increasing the effective wall thickness of the stent, and without adversely impacting the mechanical expansion properties of the stent.

[0016] It would further be advantageous to have such a stent, which also significantly increases the available depth of the beneficial agent reservoir.

[0017] It would also be advantageous to have methods of loading various beneficial agents or combinations of beneficial agents into these deep reservoirs, which provided control over the temporal release kinetics of the agents.

[0018] In accordance with one aspect of the invention, an expandable medical device includes a plurality of elongated struts, said plurality of elongated struts joined together to form a substantially cylindrical device which is expandable from a cylinder having a first diameter to a cylinder having a second diameter, said plurality of struts each having a strut width in a circumferential direction and a strut thickness in a radial direction, at least one opening in at least one of the plurality of struts, the opening extending through the strut, and at least one beneficial agent provided in the at least one opening in a plurality of layers having a thickness of 2 μ m to 50 μ m.

[0019] In accordance with another aspect of the present invention, a method of forming an expandable medical device includes providing an expandable medical device with a plurality of struts, said plurality of struts joined together to form a substantially cylindrical device which is expandable from a cylinder having a first diameter to a cylinder having a second diameter, forming at least one opening in at least one of the plurality of struts, the at last one strut opening extending through the strut, and delivering at least one beneficial agent into in the at **[deletion(s)]** least one opening in a plurality of layers

comprising the steps of delivering a solution comprising a beneficial agent, a solvent and optionally a polymer carrier, into the at least one opening; evaporating the solvent; and repeating the process until each opening is partially or entirely filled.

BRIEF DESCRIPTION OF THE DRAWINGS

[0020] The invention will now be described in greater detail with reference to the preferred embodiments illustrated in the accompanying drawings, in which like elements bear like reference numerals, and wherein:

FIG. 1 is a perspective view of a tissue supporting device in accordance with a first preferred embodiment of the present invention;

FIG. 2 is an enlarged side view of a portion of the device of FIG. 1;

FIG. 3 is an enlarged side view of a tissue supporting device in accordance with a further preferred embodiment of the present invention;

FIG. 4 is an enlarged side view of a portion of the stent shown in FIG. 3;

FIG. 5 is an enlarged cross section of an opening;

FIG. 6 is an enlarged cross section of an opening not forming part of the invention illustrating beneficial agent loaded into the opening;

FIG. 7 is an enlarged cross section of an opening not forming part of the invention illustrating a beneficial agent loaded into the opening and a thin coating of a beneficial agent;

FIG. 8 is an enlarged cross section of an opening not forming part of the invention illustrating a beneficial agent loaded into the opening and thin coatings of different beneficial agents on different surfaces of the device;

FIG. 9 is an enlarged cross section of an opening illustrating a beneficial agent provided in a plurality of layers;

FIG. 10 is an enlarged cross section of an opening illustrating a beneficial agent and a barrier layer loaded into the opening in layers;

FIG. 11A is an enlarged cross section of an opening illustrating a beneficial agent, a biodegradable carrier, and a barrier layer loaded into the opening in layers;

FIG. 11B is a graph of the release kinetics of the device of FIG. 11A;

FIG. 12 is an enlarged cross section of an opening illustrating different beneficial agents, carrier, and barrier layers loaded into the opening;

FIG. 13 is an enlarged cross section of an opening illustrating a beneficial agent loaded into the opening in layers of different concentrations;

FIG. 14 is an enlarged cross section of an opening illustrating a beneficial agent loaded into the opening in layers of microspheres of different sizes;

FIG. 15A is an enlarged cross section of a tapered

opening illustrating a beneficial agent loaded into the opening;

FIG. 15B is an enlarged cross section of the tapered opening of FIG. 15A with the beneficial agent partially degraded;

FIG. 15C is a graph of the release kinetics of the device of FIGS. 15A and 15B;

FIG. 16A is an enlarged cross section of an opening illustrating a beneficial agent loaded into the opening in a shape configured to achieve a desired agent delivery profile;

FIG. 16B is an enlarged cross section of the opening of FIG. 16A with the beneficial agent partially degraded;

FIG. 16C is a graph of the release kinetics of the device of FIGS. 16A and 16B;

FIG. 17A is an enlarged cross section of an opening illustrating the beneficial agent loaded into the opening and a spherical shape;

FIG. 17B is a graph of the release kinetics of the device of FIG. 17A;

FIG. 18A is an enlarged cross section of an opening illustrating a plurality of beneficial agent layers and a barrier layer with an opening for achieving a desired agent delivery profile;

FIG. 18B is an enlarged cross section of the opening of FIG. 18A with the agent layers beginning to degrade;

FIG. 18C is an enlarged cross section of the opening of FIG. 18A with the agent layers further degraded; and

FIG. 19 is an enlarged cross section of an opening illustrating a plurality of cylindrical beneficial agent layers.

DETAILED DESCRIPTION OF THE PREFERRED EMBODIMENTS

[0021] Referring to FIGS. 1 and 2, a tissue supporting device in accordance with one preferred embodiment of the present invention is shown generally by reference numeral 10. The tissue supporting device 10 includes a plurality of cylindrical tubes 12 connected by S-shaped bridging elements 14. The bridging elements 14 allow the tissue supporting device to bend axially when passing through the tortuous path of the vasculature to the deployment site and allow the device to bend when necessary to match the curvature of a vessel wall to be supported. Each of the cylindrical tubes 12 has a plurality of axial slots 16 extending from an end surface of the cylindrical tube toward an opposite end surface.

[0022] Formed between the slots 16 is a network of axial struts 18 and links 22. The struts 18 and links 22 are provided with openings for receiving and delivering a beneficial agent. As will be described below with respect to FIGS. 9-17, the beneficial agent is loaded into the openings in layers or other configurations which provide control over the temporal release kinetics of the

agent.

[0023] Each individual strut 18 is preferably linked to the rest of the structure through a pair of reduced sections 20, one at each end, which act as stress/strain concentration features. The reduced sections 20 of the struts function as hinges in the cylindrical structure. Since the stress/strain concentration features are designed to operate into the plastic deformation range of generally ductile materials, they are referred to as ductile hinges 20. The ductile hinges 20 are described in further detail in U.S. Pat. No. 6,241,762.

[0024] With reference to the drawings and the discussion, the *width* of any feature is defined as its dimension in the circumferential direction of the cylinder. The *length* of any feature is defined as its dimension in the axial direction of the cylinder. The *thickness* of any feature is defined as the wall thickness of the cylinder.

[0025] The presence of the ductile hinges 20 allows all of the remaining features in the tissue supporting device to be increased in width or the circumferentially oriented component of their respective rectangular moments of inertia - thus greatly increasing the strength and rigidity of these features. The net result is that elastic, and then plastic deformation commence and propagate in the ductile hinges 20 before other structural elements of the device undergo any significant elastic deformation. The force required to expand the tissue supporting device 10 becomes a function of the geometry of the ductile hinges 20, rather than the device structure as a whole, and arbitrarily small expansion forces can be specified by changing hinge geometry for virtually any material wall thickness. The ability to increase the width and thickness of the struts 18 and links 22 provides additional area and depth for the beneficial agent receiving openings.

[0026] In the preferred embodiment of FIGS. 1 and 2, it is desirable to increase the width of the individual struts 18 between the ductile hinges 20 to the maximum width that is geometrically possible for a given diameter and a given number of struts arrayed around that diameter. The only geometric limitation on strut width is the minimum practical width of the slots 16 which is about 0.002 inches (0.0508 mm) for laser machining. Lateral stiffness of the struts 18 increases as the cube of strut width, so that relatively small increases in strut width significantly increase strut stiffness. The net result of inserting ductile hinges 20 and increasing strut width is that the struts 18 no longer act as flexible leaf springs, but act as essentially rigid beams between the ductile hinges. All radial expansion or compression of the cylindrical tissue supporting device 10 is accommodated by mechanical strain in the hinge features 20, and yield in the hinge commences at very small overall radial expansion or compression.

[0027] The ductile hinge 20 illustrated in FIGS. 1 and 2 is exemplary of a preferred structure that will function as a stress/strain concentrator. Many other stress/strain concentrator configurations may also be used as the ductile hinges in the present invention, as shown and described by way of example in U.S. Pat. No. 6,241,762.

The geometric details of the stress/strain concentration features or ductile hinges 20 can be varied greatly to tailor the exact mechanical expansion properties to those required in a specific application.

[0028] Although a tissue supporting device configuration has been illustrated in FIG. 1 which includes ductile hinges, it should be understood that the beneficial agent may be contained in openings in stents having a variety of designs including the designs illustrated in U.S. Provisional Patent Application Serial No. 60/314,360, filed on August 20, 2001 and U.S. Patent Application Serial No. 09/948,987, filed on September 7, 2001, published as US 2002/0068969 A1. The present invention incorporating beneficial agent openings may also be used with other known stent designs.

[0029] As shown in FIGS. 1-4, at least one and more preferably a series of openings 24 are formed by laser drilling or any other means known to one skilled in the art at intervals along the neutral axis of the struts 18. Similarly, at least one and preferably a series of openings 26 are formed at selected locations in the links 22. Although the use of openings 24 and 26 in both the struts 18 and links 22 is preferred, it should be clear to one skilled in the art that openings could be formed in only one of the struts and links. Openings may also be formed in the bridging elements 14. In the embodiment of FIGS. 1 and 2, the openings 24, 26 are circular in nature and form cylindrical holes extending through the width of the tissue supporting device 10. It should be apparent to one skilled in the art, however, that openings of any geometrical shape or configuration could of course be used without departing from the scope of the present invention.

[0030] The behavior of the struts 18 in bending is analogous to the behavior of an I-beam or truss. The outer edge elements 32 of the struts 18, shown in FIG. 2, correspond to the I-beam flange and carry the tensile and compressive stresses, whereas the inner elements 34 of the struts 18 correspond to the web of an I-beam which carries the shear and helps to prevent buckling and wrinkling of the faces. Since most of the bending load is carried by the outer edge elements 32 of the struts 18, a concentration of as much material as possible away from the neutral axis results in the most efficient sections for resisting strut flexure. As a result, material can be judiciously removed along the axis of the strut so as to form openings 24, 26 without adversely impacting the strength and rigidity of the strut. Since the struts 18 and links 22 thus formed remain essentially rigid during stent expansion, the openings 24, 26 are also non-deforming.

[0031] The openings 24, 26 in the struts 18 may promote the healing of the intervention site by promoting regrowth of the endothelial cells. By providing the openings 24, 26 in the struts, 18, the cross section of the strut is effectively reduced without decreasing the strength and integrity of the strut, as described above. As a result, the overall distance across which endothelial cell regrowth must occur is also reduced to approximately 63-89 μm (0.0025 - 0.0035 inches), which is approxi-

mately one-half of the thickness of a conventional stent. It is further believed that during insertion of the expandable medical device, cells from the endothelial layer may be scraped from the inner wall of the vessel by the openings 24, 26 and remain therein after implantation. The presence of such endothelial cells would thus provide a basis for the healing of the vessel wall.

[0032] The openings 24, 26 are loaded with an agent, most preferably a beneficial agent, for delivery to the vessel wall which the tissue supporting device 10 is supporting.

[0033] The terms "agent" and "beneficial agent" as used herein are intended to have their broadest possible interpretation and are used to include any therapeutic agent or drug, as well as inactive agents such as barrier layers or carrier layers. The terms "drug" and "therapeutic agent" are used interchangeably to refer to any therapeutically active substance that is delivered to a bodily conduit of a living being to produce a desired, usually beneficial, effect. The present invention is particularly well suited for the delivery of antiproliferatives (anti-restenosis agents) such as paclitaxel and rapamycin for example, and antithrombins such as heparin, for example.

[0034] The beneficial agents used in the present invention include classical small molecular weight therapeutic agents commonly referred to as drugs including all classes of action as exemplified by, but not limited to: antiproliferatives, antithrombins, antiplatelet, antilipid, anti-inflammatory, and anti-angiogenic, vitamins, ACE inhibitors, vasoactive substances, antimetotics, metalloproteinase inhibitors, NO donors, estradiols, anti-sclerosing agents, alone or in combination. Beneficial agent also includes larger molecular weight substances with drug like effects on target tissue sometimes called biologic agents including but not limited to: peptides, lipids, protein drugs, enzymes, oligonucleotides, ribozymes, genetic material, prions, virus, bacteria, and eucaryotic cells such as endothelial cells, monocyte/macrophages or vascular smooth muscle cells to name but a few examples. Other beneficial agents may include but not be limited to physical agents such as microspheres, microbubbles, liposomes, radioactive isotopes, or agents activated by some other form of energy such as light or ultrasonic energy, or by other circulating molecules that can be systemically administered.

[0035] The embodiment of the invention shown in FIGS. 1 and 2 can be further refined by using Finite Element Analysis and other techniques to optimize the deployment of the beneficial agent within the openings of the struts and links. Basically, the shape and location of the openings 24, 26 can be modified to maximize the volume of the voids while preserving the relatively high strength and rigidity of the struts 18 with respect to the ductile hinges 20.

[0036] FIG. 3 illustrates a further preferred embodiment of the present invention, wherein like reference numerals have been used to indicate like components. The tissue supporting device 100 includes a plurality of cylin-

drical tubes 12 connected by S-shaped bridging elements 14. Each of the cylindrical tubes 12 has a plurality of axial slots 16 extending from an end surface of the cylindrical tube toward an opposite end surface. Formed between the slots 16 is a network of axial struts 18 and links 22. Each individual strut 18 is linked to the rest of the structure through a pair of ductile hinges 20, one at each end, which act as stress/strain concentration features. Each of the ductile hinges 20 is formed between an arc surface 28 and a concave notch surface 29.

[0037] At intervals along the neutral axis of the struts 18, at least one and more preferably a series of openings 24' are formed by laser drilling or any other means known to one skilled in the art. Similarly, at least one and preferably a series of openings 26' are formed at selected locations in the links 22. Although the use of openings 24', 26' in both the struts 18 and links 22 is preferred, it should be clear to one skilled in the art that openings could be formed in only one of the struts and links. In the illustrated embodiment, the openings 24' in the struts 18 are generally rectangular whereas the openings 26' in the links 22 are polygonal. It should be apparent to one skilled in the art, however, that openings of any geometrical shape or configuration could of course be used, and that the shape of openings 24, 24' may be the same or different from the shape of openings 26, 26', without departing from the scope of the present invention. As described in detail above, the openings 24', 26' may be loaded with an agent, most preferably a beneficial agent, for delivery to the vessel in which the tissue support device 100 is deployed.

[0038] The relatively large, protected openings 24, 24', 26, 26', as described above, make the expandable medical device of the present invention particularly suitable for delivering agents having more esoteric larger molecules or genetic or cellular agents, such as, for example, protein drugs, enzymes, antibodies, antisense oligonucleotides, ribozymes, gene/vector constructs, and cells (including but not limited to cultures of a patient's own endothelial cells). Many of these types of agents are biodegradable or fragile, have a very short or no shelf life, must be prepared at the time of use, or cannot be preloaded into delivery devices such as stents during the manufacture thereof for some other reason. The large through-openings in the expandable device of the present invention form protected areas or receptors to facilitate the loading of such an agent either at the time of use or prior to use, and to protect the agent from abrasion and extrusion during delivery and implantation.

[0039] The volume of beneficial agent that can be delivered using through openings is about 3 to 10 times greater than the volume of a 5 micron coating covering a stent with the same stent/vessel wall coverage ratio. This much larger beneficial agent capacity provides several advantages. The larger capacity can be used to deliver multi-drug combinations, each with independent release profiles, for improved efficacy. Also, larger capacity can be used to provide larger quantities of less aggres-

sive drugs and to achieve clinical efficacy without the undesirable side-effects of more potent drugs, such as retarded healing of the endothelial layer.

[0040] Through openings also decrease the surface area of the beneficial agent bearing compounds to which the vessel wall surface is exposed. For typical devices with beneficial agent openings, this exposure decreases by a factors ranging from about 6:1 to 8:1, by comparison with surface coated stents. This dramatically reduces the exposure of vessel wall tissue to polymer carriers and other agents that can cause inflammation, while simultaneously increasing the quantity of beneficial agent delivered, and improving control of release kinetics.

[0041] FIG. 4 shows an enlarged view of one of the struts 18 of device 100 disposed between a pair of ductile hinges 20 having a plurality of openings 24'. FIG. 5 illustrates a cross section of one of the openings 24' shown in FIG. 4. FIG. 6 illustrates the same cross section in an illustrative example not forming part of the invention, when a beneficial agent 36 has been loaded into the opening 24' of the strut 18. Optionally, after loading the opening 24' and/or the opening 26' with a beneficial agent 36, the entire exterior surface of the stent can be coated with a thin layer of a beneficial agent 38, which may be the same as or different from the beneficial agent 36, as schematically shown in FIG. 7 and also not forming part of the invention. Still further, another variation of the present invention would coat the outwardly facing surfaces of the stent with a first beneficial agent 38 while coating the inwardly facing surfaces of the stent with a different beneficial agent 39, as illustrated in FIG. 8 and also not forming part of the invention. The inwardly facing surface of the stent would be defined as at least the surface of the stent which, after expansion, forms the inner passage of the vessel. The outwardly facing surface of the stent would be defined as at least the surface of the stent which, after expansion, is in contact with and directly supports the inner wall of the vessel. The beneficial agent 39 coated on the inner surfaces may be a barrier layer which prevents the beneficial agent 36 from passing into the lumen of the blood vessel and being washed away in the blood stream.

[0042] FIG. 9 shows a cross section of an opening 24 in which one or more beneficial agents have been loaded into the opening 24 in discrete layers 50. One method of creating such layers is to deliver a solution comprising beneficial agent polymer carrier, and a solvent into the opening and evaporating the solvent to create a thin solid layer of beneficial agent in the carrier. Other methods of delivering the beneficial agent can also be used to create layers. According to another method for creating layers, a beneficial agent may be loaded into the openings alone if the agent is structurally viable without the need for a carrier. The process can then be repeated until each opening is partially or entirely filled.

[0043] In a typical embodiment, the total depth of the opening 24 is about 125 to about 140 microns, and the typical layer thickness would be about 2 to about 50 mi-

crons, preferably about 12 microns. Each typical layer is thus individually about twice as thick as the typical coating applied to surface-coated stents. There would be at least two and preferably about ten to twelve such layers in a typical opening, with a total beneficial agent thickness about 25 to 28 times greater than a typical surface coating. According to one preferred embodiment of the present invention, the openings have an area of at least $3.2 \times 10^{-3} \text{ mm}^2$ (5×10^{-6} square inches), and preferably at least $4.5 \times 10^{-3} \text{ mm}^2$ (7×10^{-6} square inches).

[0044] Since each layer is created independently, individual chemical compositions and pharmacokinetic properties can be imparted to each layer. Numerous useful arrangements of such layers can be formed, some of which will be described below. Each of the layers may include one or more agents in the same or different proportions from layer to layer. The layers may be solid, porous, or filled with other drugs or excipients.

[0045] FIG. 9 shows the simplest arrangement of layers including identical layers 50 that together form a uniform, homogeneous distribution of beneficial agent. If the carrier polymer were comprised of a biodegradable material, then erosion of the beneficial agent containing carrier would occur on both faces of the opening at the same time, and beneficial agent would be released at an approximately linear rate over time corresponding to the erosion rate of the carrier. This linear or constant release rate is referred to as a zero order delivery profile. Use of biodegradable carriers in combination with through openings is especially useful, to guarantee 100% discharge of the beneficial agent within a desired time without creating virtual spaces or voids between the radially outermost surface of the stent and tissue of the vessel wall. When the biodegradable material in the through openings is removed, the openings may provide a communication between the strut-covered vessel wall and the blood stream. Such communication may accelerate vessel healing and allow the ingrowth of cells and extracellular components that more thoroughly lock the stent in contact with the vessel wall. Alternatively, some through-openings may be loaded with beneficial agent while others are left unloaded. The unloaded holes could provide an immediate nidus for the ingrowth of cells and extracellular components to lock the stent into place, while loaded openings dispense the beneficial agent.

[0046] The advantage of complete erosion using the through openings over surface coated stents opens up new possibilities for stent-based therapies. In the treatment of cardiac arrhythmias, such as atrial fibrillation both sustained and paroxysmal, sustained ventricular tachycardia, super ventricular tachycardia including reentrant and ectopic, and sinus tachycardia, a number of techniques under development attempt to ablate tissue in the pulmonary veins or some other critical location using various energy sources, e.g. microwaves, generally referred to as radio-frequency ablation, to create a barrier to the propagation of undesired electrical signals in the form of scar tissue. These techniques have proven difficult to

control accurately. A stent based therapy using through openings, biodegradable carriers, and associated techniques described herein could be used to deliver a *chemically* ablative agent in a specific, precise pattern to a specific area for treatment of atrial fibrillation, while guaranteeing that none of the inherently cytotoxic ablating agent could be permanently trapped in contact with the tissue of the vessel wall.

[0047] If, on the other hand, the goal of a particular therapy is to provide a long term effect, beneficial agents located in openings provide an equally dramatic advantage over surface coated devices. In this case, a composition comprising a beneficial agent and a non-biodegradable carrier would be loaded into the through openings, preferably in combination with a diffusion barrier layer as described below. To continue the cardiac arrhythmias example, it might be desirable to introduce a long-term anti-arrhythmic drug near the ostia of the pulmonary veins or some other critical location. The transient diffusion behavior of a beneficial agent through a non-biodegradable carrier matrix can be generally described by Fick's second law:

$$\frac{\partial C_x}{\partial t} = \frac{\partial}{\partial x} \left[D \frac{\partial C_x}{\partial x} \right]$$

Where C is the concentration of beneficial agent at cross section x, x is either the thickness of a surface coating or depth of a through opening, D is the diffusion coefficient and t is time. The solution of this partial differential equation for a through opening with a barrier layer will have the form of a *normalized probability integral* or *Gaussian Error Function*, the argument of which will contain the term

$$\frac{x}{2\sqrt{Dt}}$$

To compare the time intervals over which a given level of therapy can be sustained for surface coatings vs. through openings, we can use Fick's Second Law to compare the times required to achieve equal concentrations at the most inward surfaces of the coating and opening respectively, i.e. the values of x and t for which the arguments of the Error Function are equal:

$$\frac{x_1}{2\sqrt{Dt_1}} = \frac{x_2}{2\sqrt{Dt_2}} \Rightarrow \frac{x_1^2}{x_2^2} = \frac{t_1}{t_2}$$

The ratio of diffusion times to achieve comparable concentrations thus varies as the square of the ratio of depths. A typical opening depth is about 140 microns while a typical coating thickness is about 5 micron; the square of this ratio is 784, meaning that the effective duration of therapy for through openings is potentially almost three orders of magnitude greater for through openings than for surface coatings of the same composition. The inherent non-linearity of such release profiles can in part be compensated for in the case of through openings, but not in thin surface coatings, by varying the beneficial agent concentration of layers in a through opening as described below. It will be recalled that, in addition to this great advantage in beneficial agent delivery *duration*, through openings are capable of delivering a 3 to 10 times greater *quantity* of beneficial agent, providing a decisive overall advantage in sustained therapies. The diffusion example above illustrates the general relationship between depth and diffusion time that is characteristic of a wider class of solid state transport mechanisms.

[0048] Beneficial agent that is released to the radially innermost or inwardly facing surface known as the lumen facing surface of an expanded device may be rapidly carried away from the targeted area, for example by the bloodstream, and thus lost. Up to half of the total agent loaded in such situations may have no therapeutic effect due to being carried away by the bloodstream. This is probably the case for all surface coated stents as well as the through opening device of FIG. 9.

[0049] FIG. 10 shows a device in which the first layer 52 is loaded into a through opening 24 such that the inner surface of the layer is substantially co-planar with the inwardly facing surface 54 of the cylindrical device. The first layer 52 is comprised of a material called a barrier material which blocks or retards biodegradation of subsequent layers in the inwardly facing direction toward the vessel lumen, and/or blocks or retards diffusion of the beneficial agent in that direction. Biodegradation of other layers or beneficial agent diffusion can then proceed only in the direction of the outwardly facing surface 56 of the device, which is in direct contact with the targeted tissue of the vessel wall. The barrier layer 52 may also function to prevent hydration of inner layers of beneficial agent and thus prevent swelling of the inner layers when such layers are formed of hygroscopic materials. The barrier layer 52 may further be comprised of a biodegradable material that degrades at a much slower rate than the biodegradable material in the other layers, so that the opening will eventually be entirely cleared. Providing a barrier layer 52 in the most inwardly facing surface of a through-opening thus guarantees that the entire load of beneficial agent is delivered to the target area in the vessel wall. It should be noted that providing a barrier layer on the inwardly facing surface of a surface-coated stent without openings *does not* have the same effect; since the beneficial agent in such a coating cannot migrate through the metal stent to the target area on the outer surface, it simply remains trapped on the inner diameter

of the device, again having no therapeutic effect.

[0050] Barrier layers can be used to control beneficial agent release kinetics in more sophisticated ways. A barrier layer 52 with a pre-determined degradation time could be used to deliberately terminate the beneficial agent therapy at a pre-determined time, by exposing the underlying layers to more rapid bio-degradation from both sides. Barrier layers can also be formulated to be activated by a separate, systemically applied agent. Such systemically applied agent could change the porosity of the barrier layer and/or change the rate of bio-degradation of the barrier layer or the bulk beneficial agent carrier. In each case, release of the beneficial agent could be activated by the physician at will by delivery of the systemically applied agent. A further embodiment of physician activated therapy would utilize a beneficial agent encapsulated in micro-bubbles and loaded into device openings. Application of ultrasonic energy from an exterior of the body could be used to collapse the bubbles at a desired time, releasing the beneficial agent to diffuse to the outwardly facing surface of the reservoirs. These activation techniques can be used in conjunction with the release kinetics control techniques described herein to achieve a desired drug release profile that can be activated and/or terminated at selectable points in time.

[0051] FIG. 11A shows an arrangement of layers provided in a through opening in which layers 50 of a beneficial agent in a biodegradable carrier material, are alternated with layers 58 of the biodegradable carrier material alone, with no active agent loaded, and a barrier layer 52 is provided at the inwardly facing surface. As shown in the release kinetics plot of FIG. 11B, such an arrangement releases beneficial agent in three programmable bursts or waves achieving a stepped or pulsatile delivery profile. The use of carrier material layers without active agent creates the potential for synchronization of drug release with cellular biochemical processes for enhanced efficacy.

[0052] Alternatively, different layers could be comprised of different beneficial agents altogether, creating the ability to release different beneficial agents at different points in time, as shown in FIG. 12. For example, in FIG. 12, a layer 60 of anti-thrombotic agent could be deposited at the inwardly facing surface of the stent, followed by a barrier layer 52 and alternating layers of anti-proliferatives 62 and anti-inflammatories 64. This configuration could provide an initial release of anti-thrombotic agent into the bloodstream while simultaneously providing a gradual release of anti-proliferatives interspersed with programmed bursts of anti-inflammatory agents to the vessel wall. The configurations of these layers can be designed to achieve the agent delivery bursts at particular points in time coordinated with the body's various natural healing processes.

[0053] A further alternative is illustrated in FIG. 13. Here the concentration of the same beneficial agent is varied from layer to layer, creating the ability to generate release profiles of arbitrary shape. Progressively increas-

ing the concentration of agent in the layers 66 with increasing distance from the outwardly facing surface 56, for example, produces a release profile with a progressively increasing release rate, which would be impossible to produce in a thin surface coating.

[0054] Another general method for controlling beneficial agent release kinetics is to alter the beneficial agent flux by changing the surface area of drug elution sources as a function of time. This follows from Fick's First Law, which states that the instantaneous molecular flux is proportional to surface area, among other factors:

$$J = D \frac{\partial C}{\partial x} \Rightarrow \frac{\partial N}{\partial t} = AD \frac{\partial c}{\partial x}$$

Where $\partial N/\partial t$ is the number of molecules per unit time, A is the instantaneous drug eluting surface area, D is the diffusivity, and C is the concentration. The drug eluting surface area of a surface coated stent is simply the surface area of the stent itself. Since this area is fixed, this method of controlling release kinetics is not available to surface coated devices. Through openings, however, present several possibilities for varying surface area as a function of time.

[0055] In the embodiment of FIG. 14, beneficial agent is provided in the openings 24 in the form of microspheres, particles or the like. Individual layers 70 can then be created that contain these particles. Further, the particle size can be varied from layer to layer. For a given layer volume, smaller particle sizes increase the total particle surface area in that layer, which has the effect of varying the total surface area of the beneficial agent from layer to layer. Since the flux of drug molecules is proportional to surface area, the total drug flux can be adjusted from layer to layer by changing the particle size, and the net effect is control of release kinetics by varying particle sizes within layers.

[0056] A second general method for varying drug eluting surface area as a function of time is to change the shape or cross-sectional area of the drug-bearing element along the axis of the opening. FIG. 15A shows an opening 70 having a conical shape cut into the material of the stent itself. The opening 70 may then be filled with beneficial agent 72 in layers as described above or in another manner. In this embodiment, a barrier layer 74 may be provided on the inwardly facing side of the opening 70 to prevent the beneficial agent 72 from passing into the blood stream. In this example, the drug eluting surface area A, would continuously diminish (from FIG. 15A to FIG. 15B) as the bio-degradable carrier material erodes, yielding the elution pattern of FIG. 15C.

[0057] FIG. 16A shows a simple cylindrical through-opening 80 in which a preformed, inverted cone 82 of beneficial agent has been inserted. The rest of the through opening 80 is then back-filled with a biodegrad-

able substance 84 with a much slower rate of degradation or a non-biodegradable substance, and the inwardly facing opening of the through opening is sealed with a barrier layer 86. This technique yields the opposite behavior to the previous example. The drug-eluting surface area A, continuously increases with time between FIG. 16A and 16B, yielding the elution pattern of FIG. 16C.

[0058] The changing cross section openings 70 of FIG. 15A and the non-biodegradable backfilling techniques of FIG. 16A may be combined with any of the layered agent embodiments of FIGS. 9-14 to achieve desired release profiles. For example, the embodiment of FIG. 15A may use the varying agent concentration layers of FIG. 13 to more accurately tailor a release curve to a desired profile.

[0059] The process of preforming the beneficial agent plug 82 to a special shape, inserting in a through opening, and back-filling with a second material can yield more complex release kinetics as well. FIG. 17A shows a through opening 90 in which a spherical beneficial agent plug 92 has been inserted. The resulting biodegradation of the sphere, in which the cross sectional surface area varies as a sinusoidal function of depth, produces a flux density which is roughly a sinusoidal function of time, FIG. 17B. Other results are of course possible with other profiles, but none of these more complex behaviors could be generated in a thin, fixed-area surface coating.

[0060] An alternative embodiment of FIGS. 18A-18C use a barrier layer 52' with an opening 96 to achieve the increasing agent release profile of FIG. 16C. As shown in FIG. 18A, the opening 24 is provided with an inner barrier layer 52 and multiple beneficial agent layers 50 as in the embodiment of FIG. 10. An additional outer barrier layer 52' is provided with a small hole 96 for delivery of the agent to the vessel wall. As shown in FIGS. 18B and 18C, the beneficial agent containing layers 50 degrade in a hemispherical pattern resulting in increasing surface area for agent delivery over time and thus, an increasing agent release profile.

[0061] FIG. 19 illustrates an alternative embodiment in which an opening in the tissue supporting device is loaded with cylindrical layers of beneficial agent. According to one method of forming the device of FIG. 19, the entire device is coated with sequential layers 100, 102, 104, 106 of beneficial agent. The interior surface 54 and exterior surface 56 of the device are then stripped to remove the beneficial agent on these surfaces leaving the cylindrical layers of beneficial agent in the openings. In this embodiment, a central opening remains after the coating layers have been deposited which allows communication between the outer surface 56 and inner surface 54 of the tissue supporting device.

[0062] In the embodiment of FIG. 19, the cylindrical layers are eroded sequentially. This can be used for pulsatile delivery of different beneficial agents, delivery of different concentrations of beneficial agents, or delivery of the same agent. As shown in FIG. 19, the ends of the cylindrical layers 100, 102, 104, 106 are exposed. This results in a low level of erosion of the underlying layers

during erosion of an exposed layer. Alternatively, the ends of the cylindrical layers may be covered by a barrier layer to prevent this low level continuous erosion. Erosion rates of the cylindrical layers may be further controlled by contouring the surfaces of the layers. For example, a ribbed or star-shaped pattern may be provided on the radially inner layers to provide a uniform surface area or uniform erosion rate between the radially inner layers and the radially outer layers. Contouring of the surfaces of layers may also be used in other embodiments to provide an additional variable for controlling the erosion rates.

[0063] While the invention has been described in detail with reference to the preferred embodiments thereof, it will be apparent to one skilled in the art that various changes and modifications can be made and equivalents employed, without departing from the present invention, as defined in the appended claims.

Claims

1. An expandable medical device (10) comprising:
 - a plurality of elongated struts (18), said plurality of elongated struts (18) joined together to form a substantially cylindrical device which is expandable from a cylinder having a first diameter to a cylinder having a second diameter;
 - strut openings (24, 26) in at least one of the plurality of struts, (18) the strut openings (24, 26) extending through the strut;
 - and at least one beneficial agent delivered into the strut openings (24, 26) in a plurality of layers, wherein a layer thickness is 2 μm to 50 μm .
2. The expandable medical device according to Claim 1, wherein the at least one strut opening has a substantially constant cross section from a radially outermost surface of the strut to a radially innermost end of the at least one strut opening.
3. The expandable medical device according to Claim 1, wherein said at least one strut opening comprises a plurality of strut openings.
4. The expandable medical device according to Claim 1, wherein said plurality of beneficial agent layers include layers of different chemical compositions.
5. The expandable medical device according to Claim 4, wherein said different chemical compositions include a barrier composition and an active beneficial agent composition.
6. The expandable medical device according to Claim 5, wherein said barrier composition has an opening formed therein.

7. The expandable medical device according to Claim 4, wherein said different chemical compositions include different active beneficial agents.
8. The expandable medical device according to Claim 7, wherein said different active beneficial agents include anti-thrombotic agents and anti-proliferative agents.
9. The expandable medical device according to Claim 1, wherein said plurality of beneficial agent layers include layers of beneficial agent having the same chemical composition in different concentrations.
10. The expandable medical device according to Claim 1, wherein said plurality of beneficial agent layers include a barrier layer at a radially innermost location in the at least one strut opening.
11. The expandable medical device according to Claim 1, wherein the plurality of beneficial agent layers include a barrier layer between two active beneficial agent layers.
12. The expandable medical device according to Claim 1, wherein said beneficial agent is formulated to be activated by a systemically applied agent.
13. The expandable medical device according to Claim 12, wherein said systemically applied agent is ultrasound.
14. The expandable medical device according to Claim 12, wherein said systemically applied agent is a chemical agent.
15. The expandable medical device according to Claim 1, wherein the beneficial agent is contained in microspheres.
16. The expandable medical device according to Claim 15, wherein said plurality of layers include layers with microspheres of different sizes.
17. The expandable medical device according to Claim 1, wherein the at least one strut opening has a shape configured to vary the release rate of a beneficial agent over time.
18. The expandable medical device according to Claim 1, wherein the beneficial agent is provided in the at least one strut opening in a biodegradable carrier.
19. The expandable medical device according to Claim 1, wherein the beneficial agent is configured to diffuse from a carrier in the at least one strut opening.
20. The expandable medical device according to Claim 1, wherein the beneficial agent layers include a biodegradable barrier layer configured to terminate a therapy at a predetermined time.
21. The expandable medical device according to Claim 1, wherein the beneficial agent is paclitaxel, or an analogue or derivative thereof.
22. The expandable medical device according to Claim 1, wherein the beneficial agent is rapamycin, or an analogue or derivative thereof.
23. The expandable medical device according to Claim 1, wherein the at least one opening comprises a plurality of openings containing the beneficial agent and a plurality of openings remaining open for anchoring purposes.
24. The expandable medical device according to Claim 1, wherein the plurality of beneficial agent layers are substantially cylindrical.
25. The expandable medical device according to Claim 1, further comprising barrier layer at a first surface of the plurality of struts which substantially prevents an active beneficial agent from being delivered from the at least one strut opening to the first surface of the struts.
26. The expandable medical device according to Claim 25, wherein the barrier layer is coated on the device.
27. The expandable medical device according to Claim 25, wherein the barrier layer is loaded in the at least one strut opening.
28. The expandable medical device according to Claim 1, further comprising a barrier layer provided at the radial innermost end of the at least one strut opening, the barrier layer degrading more slowly than the beneficial agent layers, and the barrier layer substantially preventing fluid passage there through.
29. The expandable medical device according to Claim 1, wherein the beneficial agent is a protein drug.
30. The expandable medical device according to Claim 1, wherein the plurality of layers of beneficial agent are arranged on top of one another in the radial direction.
31. A method of forming an expandable medical device (10), the method comprising:
 providing an expandable medical device with a plurality of struts (18), said plurality of struts (18) joined together to form a substantially cylindrical device which is expandable from a cylinder hav-

- ing a first diameter to a cylinder having a second diameter;
forming at least one strut opening (24, 26) in at least one of the plurality of struts (18), the at least one strut opening (24, 26) extending through the strut; and
delivering at least one beneficial agent into the at least one strut opening in a plurality of layers, comprising the steps of:
- delivering a solution comprising a beneficial agent, a solvent, and optionally a polymer carrier, into the at least one opening;
 - evaporating the solvent; and
 - repeating the process until each opening is partially or entirely filled.
32. The method according to Claim 31, wherein the at least one strut opening has a substantially constant cross section from a radially outermost surface of the strut to a radially innermost end of the at least one strut opening.
33. The method according to Claim 31, wherein said at least one strut opening comprises a plurality of strut openings.
34. The method according to Claim 31, wherein the beneficial agent delivered is paclitaxel, or an analogue or derivative thereof.
35. The method according to Claim 31, wherein the beneficial agent delivered is rapamycin, or an analogue or derivative thereof.
36. The method according to Claim 31, wherein the beneficial agent delivered is a protein drug.
37. The method according to Claim 31, further comprising positioning a barrier layer to substantially prevent an active beneficial agent from being delivered from the at least one strut opening to one side of the medical device while allowing active beneficial agent to be delivered to another side of the medical device.
38. The method according to Claim 37, wherein the barrier layer is coated on the device.
39. The method according to Claim 37, wherein the barrier layer is loaded in the strut openings.
40. The method according to Claim 31, wherein the plurality of layers of beneficial agent are arranged on top of one another in the radial direction.

Patentansprüche

1. Expandierbare medizinische Vorrichtung (10), umfassend:
 - mehrere längliche Streben (18), wobei die mehreren Streben (18) miteinander zu einer im Wesentlichen zylindrischen Vorrichtung verbunden sind, welche von einem Zylinder mit einem ersten Durchmesser zu einem Zylinder mit einem zweiten Durchmesser expandierbar ist; Strebenöffnungen (24, 26) in wenigstens einer der mehreren Streben (18), wobei die Strebenöffnungen (24, 26) sich durch die Strebe erstrecken;
 - wenigstens ein nützliches Agens, welches in mehreren Lagen in die Strebenöffnungen (24, 26) eingebracht ist, wobei eine Lagendicke von 2 µm bis 50 µm beträgt.
2. Expandierbare medizinische Vorrichtung gemäß Anspruch 1, wobei die wenigstens eine Strebenöffnung einen im Wesentlichen konstanten Querschnitt von einer radial äußersten Oberfläche der Strebe zu einem radial innersten Ende der wenigstens einen Strebenöffnung aufweist.
3. Expandierbare medizinische Vorrichtung gemäß Anspruch 1, wobei die wenigstens eine Strebenöffnung mehrere Strebenöffnungen umfasst.
4. Expandierbare medizinische Vorrichtung gemäß Anspruch 1, wobei die mehreren Lagen nützlichen Agens' Lagen unterschiedlicher chemischer Zusammensetzungen umfassen.
5. Expandierbare medizinische Vorrichtung gemäß Anspruch 4, wobei die unterschiedlichen chemischen Zusammensetzungen eine Barrierenzusammensetzung und eine Zusammensetzung eines aktiven nützlichen Agens umfassen.
6. Expandierbare medizinische Vorrichtung gemäß Anspruch 5, wobei in der Barrierenzusammensetzung eine Öffnung gebildet ist.
7. Expandierbare medizinische Vorrichtung gemäß Anspruch 4, wobei die unterschiedlichen chemischen Zusammensetzungen unterschiedliche aktive nützliche Agenzien umfassen.
8. Expandierbare medizinische Vorrichtung gemäß Anspruch 7, wobei die unterschiedlichen aktiven nützlichen Agenzien Anti-Thrombose-Mittel und antiproliferative Mittel umfassen.
9. Expandierbare medizinische Vorrichtung gemäß

- Anspruch 1, wobei die mehreren Lagen nützlichen Agens' Lagen nützlichen Agens' mit der gleichen chemischen Zusammensetzung in unterschiedlichen Konzentrationen umfassen.
10. Expandierbare medizinische Vorrichtung gemäß Anspruch 1, wobei die mehreren Lagen nützlichen Agens' eine Barrierenlage an einer radial innersten Stelle in der wenigstens einen Strebenöffnung umfassen.
11. Expandierbare medizinische Vorrichtung gemäß Anspruch 1, wobei die mehreren Lagen nützlichen Agens' eine Barrierenlage zwischen zwei Lagen aktiver nützlicher Agenzien umfassen.
12. Expandierbare medizinische Vorrichtung gemäß Anspruch 1, wobei das nützliche Agens so formuliert ist, dass es von einem systemisch angewandten Agens aktiviert wird.
13. Expandierbare medizinische Vorrichtung gemäß Anspruch 12, wobei das systemisch angewandte Agens Ultraschall ist.
14. Expandierbare medizinische Vorrichtung gemäß Anspruch 12, wobei das systemisch angewandte Agens ein chemisches Agens ist.
15. Expandierbare medizinische Vorrichtung gemäß Anspruch 1, wobei das nützliche Agens in Mikrokügelchen enthalten ist.
16. Expandierbare medizinische Vorrichtung gemäß Anspruch 15, wobei die mehreren Lagen mit Mikrokügelchen unterschiedlicher Größen umfassen.
17. Expandierbare medizinische Vorrichtung gemäß Anspruch 1, wobei die wenigstens eine Strebenöffnung eine Form aufweist, die dazu konfiguriert ist, die Abgaberate eines nützlichen Agens über die Zeit hinweg zu ändern.
18. Expandierbare medizinische Vorrichtung gemäß Anspruch 1, wobei das nützliche Agens in der wenigstens einen Strebenöffnung in einem biologisch abbaubaren Träger bereitgestellt ist.
19. Expandierbare medizinische Vorrichtung gemäß Anspruch 1, wobei das nützliche Agens so konfiguriert ist, dass es aus einem Träger in der wenigstens einen Strebenöffnung diffundiert.
20. Expandierbare medizinische Vorrichtung gemäß Anspruch 1, wobei die Lagen nützlichen Agens' eine biologisch abbaubare Barrierenlage umfassen, welche dazu konfiguriert ist, eine Therapie zu einer vor-
- bestimmten Zeit zu beenden.
21. Expandierbare medizinische Vorrichtung gemäß Anspruch 1, wobei das nützliche Agens Paclitaxel oder ein Analoges oder Derivat davon ist.
22. Expandierbare medizinische Vorrichtung gemäß Anspruch 1, wobei das nützliche Agens Rapamycin oder ein Analoges oder Derivat davon ist.
23. Expandierbare medizinische Vorrichtung gemäß Anspruch 1, wobei die wenigstens eine Öffnung mehrere Öffnungen umfasst, welche das nützliche Agens enthalten, und mehrere Öffnungen, die zu Verankerungszwecken offen bleiben.
24. Expandierbare medizinische Vorrichtung gemäß Anspruch 1, wobei die mehreren Lagen nützlichen Agens' im Wesentlichen zylindrisch sind.
25. Expandierbare medizinische Vorrichtung gemäß Anspruch 1, ferner umfassend eine Barrierenlage an einer ersten Oberfläche der mehreren Streben, welche ein aktives nützliches Agens im Wesentlichen daran hindert, von der wenigstens einen Strebenöffnung zu der ersten Oberfläche der Streben transportiert zu werden.
26. Expandierbare medizinische Vorrichtung gemäß Anspruch 25, wobei die Vorrichtung mit der Barrierenlage beschichtet ist.
27. Expandierbare medizinische Vorrichtung gemäß Anspruch 25, wobei die Barrierenlage in die wenigstens eine Strebenöffnung eingebracht ist.
28. Expandierbare medizinische Vorrichtung gemäß Anspruch 1, ferner umfassend eine Barrierenlage, welche an dem radial innersten Ende der wenigstens einen Strebenöffnung bereitgestellt ist, wobei die Barrierenlage langsamer abgebaut wird als die Lagen nützlichen Agens', und wobei die Barrierenlage Fluiddurchtritt durch sie hindurch im Wesentlichen verhindert.
29. Expandierbare medizinische Vorrichtung gemäß Anspruch 1, wobei das nützliche Agens ein Protein- arzneimittel ist.
30. Expandierbare medizinische Vorrichtung gemäß Anspruch 1, wobei die mehreren Lagen nützlichen Agens' in radialer Richtung aufeinander angeordnet sind.
31. Verfahren zum Bilden einer expandierbaren medizinischen Vorrichtung (10), wobei das Verfahren umfasst:

- Bereitstellen einer expandierbaren medizinischen Vorrichtung mit mehreren Streben (18), wobei die mehreren Streben (18) miteinander zu einer im Wesentlichen zylindrischen Vorrichtung verbunden sind, welche von einem Zylinder mit einem ersten Durchmesser zu einem Zylinder mit einem zweiten Durchmesser expandierbar ist;
- Bilden wenigstens einer Strebenöffnung (24, 26) in wenigstens einer der mehreren Streben (18), wobei die wenigstens eine Strebenöffnung (24, 26) sich durch die Strebe erstreckt; und Einbringen wenigstens eines nützlichen Agens in mehreren Lagen in die wenigstens eine Strebenöffnung, umfassend die folgenden Schritte:
- Einbringen einer Lösung, welche ein nützliches Agens, ein Lösungsmittel und optional einen Polymerträger umfasst, in die wenigstens eine Öffnung;
 - Verdampfen des Lösungsmittels; und
 - Wiederholen des Prozesses, bis jede Öffnung teilweise oder ganz gefüllt ist.
32. Verfahren gemäß Anspruch 31, wobei die wenigstens eine Strebenöffnung einen im Wesentlichen konstanten Querschnitt von einer radial äußersten Oberfläche der Strebe zu einem radial innersten Ende der wenigstens einen Strebenöffnung aufweist.
33. Verfahren gemäß Anspruch 31, wobei die wenigstens eine Strebenöffnung mehrere Strebenöffnungen umfasst.
34. Verfahren gemäß Anspruch 31, wobei das nützliche Agens Paclitaxel oder ein Analoges oder Derivat davon ist.
35. Verfahren gemäß Anspruch 31, wobei das nützliche Agens Rapamycin oder ein Analoges oder Derivat davon ist.
36. Verfahren gemäß Anspruch 31, wobei das nützliche Agens ein Proteinarzneimittel ist.
37. Verfahren gemäß Anspruch 31, ferner umfassend Anordnen einer Barrierenlage derart, dass ein aktives nützliches Agens im Wesentlichen daran gehindert wird, von der wenigstens einen Strebenöffnung zu einer Seite der medizinischen Vorrichtung transportiert zu werden, während es dem aktiven nützlichen Agens ermöglicht wird, zu einer anderen Seite der medizinischen Vorrichtung transportiert zu werden.
38. Verfahren gemäß Anspruch 37, wobei die medizinische Vorrichtung mit der Barrierenlage beschichtet ist.
39. Verfahren gemäß Anspruch 37, wobei die Barrierenlage in die Strebenöffnungen eingebracht ist.
40. Verfahren gemäß Anspruch 31, wobei die mehreren Lagen nützlichen Agens' in radialer Richtung aufeinander angeordnet werden.

Revendications

1. Dispositif médical extensible (10) comprenant :

une pluralité de montants allongés (18), ladite pluralité de montants allongés (18) étant reliés entre eux pour former un dispositif sensiblement cylindrique qui est extensible à partir d'un cylindre ayant un premier diamètre en un cylindre ayant un second diamètre ;
des ouvertures de montant (24, 26) dans au moins une de la pluralité des montants (18), les ouvertures de montant (24, 26) s'étendant à travers le montant ; et
au moins un agent utile dispensé dans les ouvertures de montant (24, 26) dans une pluralité de couches,
dans lequel un épaisseur de couches est de 2 μm à 50 μm .

2. Dispositif médical extensible selon la revendication 1, dans lequel au moins une ouverture de montant comporte une section transversale sensiblement constante à partir d'une surface radialement externe du montant vers une extrémité radialement interne d'au moins une ouverture de montant.

3. Dispositif médical extensible selon la revendication 1, dans lequel au moins une ouverture de montant comprend une pluralité d'ouvertures de montant.

4. Dispositif médical extensible selon la revendication 1, dans lequel ladite pluralité de couches d'agent utile comprend des couches de différentes compositions chimiques.

5. Dispositif médical extensible selon la revendication 4, dans lequel lesdites compositions chimiques différentes comprennent une composition barrière et une composition d'agent utile actif.

6. Dispositif médical extensible selon la revendication 5, dans lequel ladite composition barrière comprend une ouverture formée à l'intérieur de celui-ci.

7. Dispositif médical extensible selon la revendication 4, dans lequel lesdites différentes compositions chimiques comprennent différents agents utiles actifs.

8. Dispositif médical extensible selon la revendication

- 7, dans lequel lesdits différents agents utiles actifs comprennent des agents anti-thrombotiques et des agents anti-prolifératifs.
9. Dispositif médical extensible selon la revendication 1, dans lequel ladite pluralité de couches d'agent utile comprend des couches d'agent utile ayant la même composition dans différentes concentrations. 5
10. Dispositif médical extensible selon la revendication 1, dans lequel ladite pluralité de couches d'agent utile comprend une couche barrière à un emplacement radialement interne dans au moins une ouverture de montant. 10
11. Dispositif médical extensible selon la revendication 1, dans lequel la pluralité de couches d'agent utile comprend une couche barrière entre deux couches d'agent utile actif. 15
12. Dispositif médical extensible selon la revendication 1, dans lequel ledit agent utile est formulé pour être activé par un agent appliqué systématiquement. 20
13. Dispositif médical extensible selon la revendication 12, dans lequel ledit agent appliqué systématiquement est ultrasonore. 25
14. Dispositif médical extensible selon la revendication 12, dans lequel ledit agent appliqué systématiquement est un agent chimique. 30
15. Dispositif médical extensible selon la revendication 1, dans lequel l'agent utile est contenu dans des microsphères. 35
16. Dispositif médical extensible selon la revendication 15, dans lequel ladite pluralité de couches comprend des couches avec des microsphères de différentes tailles. 40
17. Dispositif médical extensible selon la revendication 1, dans lequel au moins une ouverture de montant a une forme configurée pour modifier le taux de distribution d'un agent utile au cours du temps. 45
18. Dispositif médical extensible selon la revendication 1, dans lequel ledit agent utile est dispensé dans au moins une ouverture de montant dans un véhicule biodégradable. 50
19. Dispositif médical extensible selon la revendication 1, dans lequel l'agent utile est configuré pour diffuser à partir d'un véhicule dans au moins une ouverture de montant. 55
20. Dispositif médical extensible selon la revendication 1, dans lequel les couches d'agent utile comprennent un véhicule biodégradable configuré pour terminer une thérapie à un moment prédéterminé.
21. Dispositif médical extensible selon la revendication 1, dans lequel l'agent utile est du placlitaxel ou un analogue ou dérivé de celui-ci.
22. Dispositif médical extensible selon la revendication 1, dans lequel l'agent utile est de la rapamycine ou un analogue ou dérivé de celle-ci.
23. Dispositif médical extensible selon la revendication 1, dans lequel au moins une ouverture comprend une pluralité d'ouvertures contenant l'agent utile et une pluralité d'ouvertures restantes ouvertes afin de servir d'ancrage.
24. Dispositif médical extensible selon la revendication 1, dans lequel la pluralité de couches d'agent utile est sensiblement cylindrique.
25. Dispositif médical extensible selon la revendication 1, comprenant en outre une couche barrière à une première surface de la pluralité des montants qui empêche sensiblement un agent utile actif d'être dispensé à partir d'au moins une ouverture de montant à la première surface des montants.
26. Dispositif médical extensible selon la revendication 25, dans lequel ladite couche barrière est plaquée sur le dispositif.
27. Dispositif médical extensible selon la revendication 25, dans lequel la couche barrière est chargée dans au moins une ouverture de montant.
28. Dispositif médical extensible selon la revendication 1, comprenant en outre une couche barrière fournie à l'extrémité radialement interne d'au moins une ouverture de montant, la couche barrière se dégradant plus lentement que les couches d'agent utile, et la couche barrière empêchant sensiblement le passage du fluide à travers celle-ci.
29. Dispositif médical extensible selon la revendication 1, dans lequel l'agent utile est un médicament protéique.
30. Dispositif médical extensible selon la revendication 1, dans lequel la pluralité de couches d'agent utile est agencée sur le sommet d'une autre dans la direction radiale.
31. Procédé de formation d'un dispositif médical extensible (10), le procédé comprenant :
- la fourniture d'un dispositif médical extensible avec une pluralité de montants (18), ladite plu-

- ralité de montants (18) étant reliés entre eux pour former un dispositif sensiblement cylindrique qui est extensible à partir d'un cylindre ayant un premier diamètre en un cylindre ayant un second diamètre ;
la formation d'au moins une ouverture de montant (24, 26) dans au moins une de la pluralité des montants (18), au moins une desdites ouvertures de montant (24, 26) s'étendant à travers le montant ; et
la distribution d'au moins un agent utile dans au moins une desdites ouvertures de montant dans une pluralité de couches comprenant les étapes consistant à :
- dispenser une solution comprenant un agent utile, un solvant, et éventuellement un véhicule polymère, dans au moins une desdites ouvertures ;
 - évaporer le solvant ; et
 - répéter le processus jusqu'à ce que chaque ouverture soit partiellement ou entièrement remplie.
- 32.** Procédé selon la revendication 31, dans lequel au moins une ouverture de montant a une section transversale sensiblement constante à partir d'une surface radialement externe de montant vers une extrémité radialement interne d'au moins une ouverture de montant.
- 33.** Procédé selon la revendication 31, dans lequel au moins une ouverture de montant comprend une pluralité d'ouvertures de montant.
- 34.** Procédé selon la revendication 31, dans lequel l'agent utile dispensé est du placlitaxel ou un analogue ou dérivé de celui-ci.
- 35.** Procédé selon la revendication 31, dans lequel l'agent utile dispensé est de la rapamycine ou un analogue ou dérivé de celle-ci.
- 36.** Procédé selon la revendication 31, dans lequel l'agent utile dispensé est un médicament protéique.
- 37.** Procédé selon la revendication 31, comprenant en outre le positionnement d'une couche barrière pour empêcher sensiblement un agent utile actif d'être dispensé à partir d'au moins une ouverture de montant vers un côté du dispositif médical tout en permettant à l'agent utile actif d'être dispensé vers l'autre côté du dispositif médical.
- 38.** Procédé selon la revendication 37, dans lequel la couche barrière est plaquée sur le dispositif.
- 39.** Procédé selon la revendication 37, dans lequel la
- couche barrière est chargée dans les ouvertures de montant.
- 40.** Procédé selon la revendication 31, dans lequel la pluralité des couches d'agent utile sont agencées sur le sommet d'une autre dans la direction radiale.

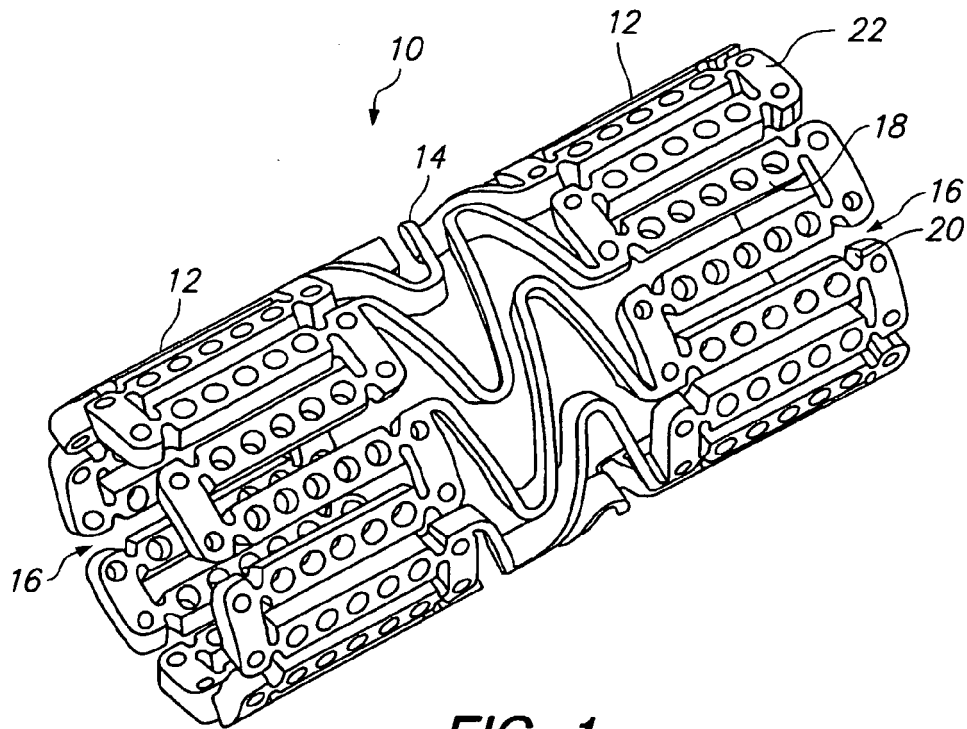

FIG. 1

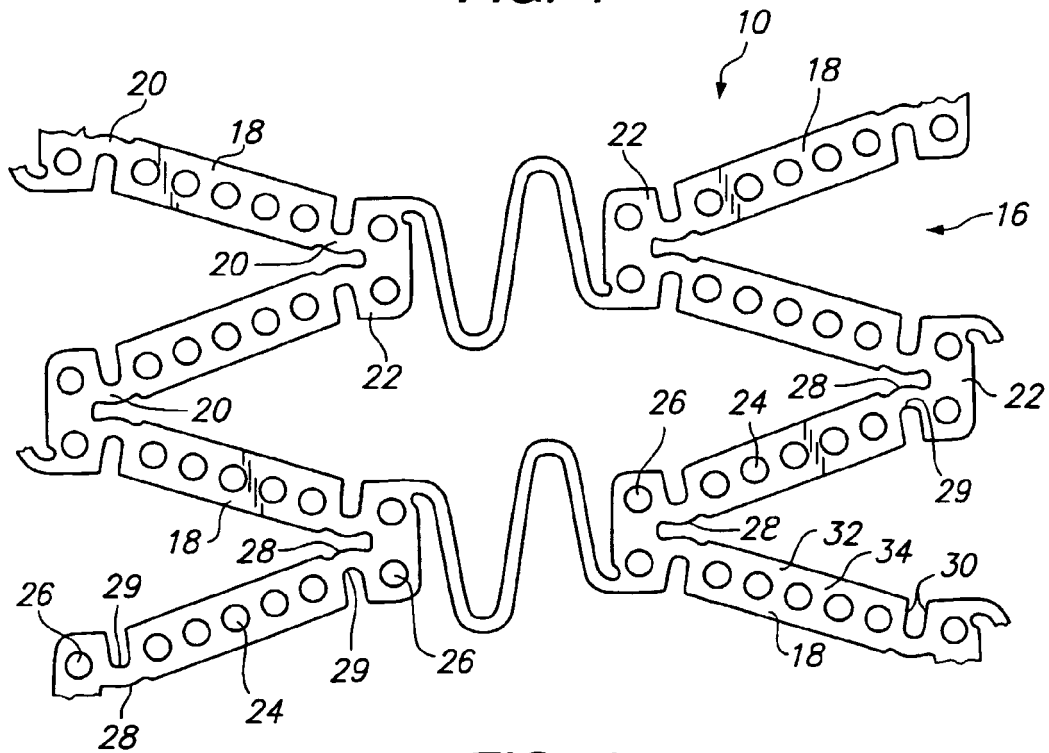

FIG. 2

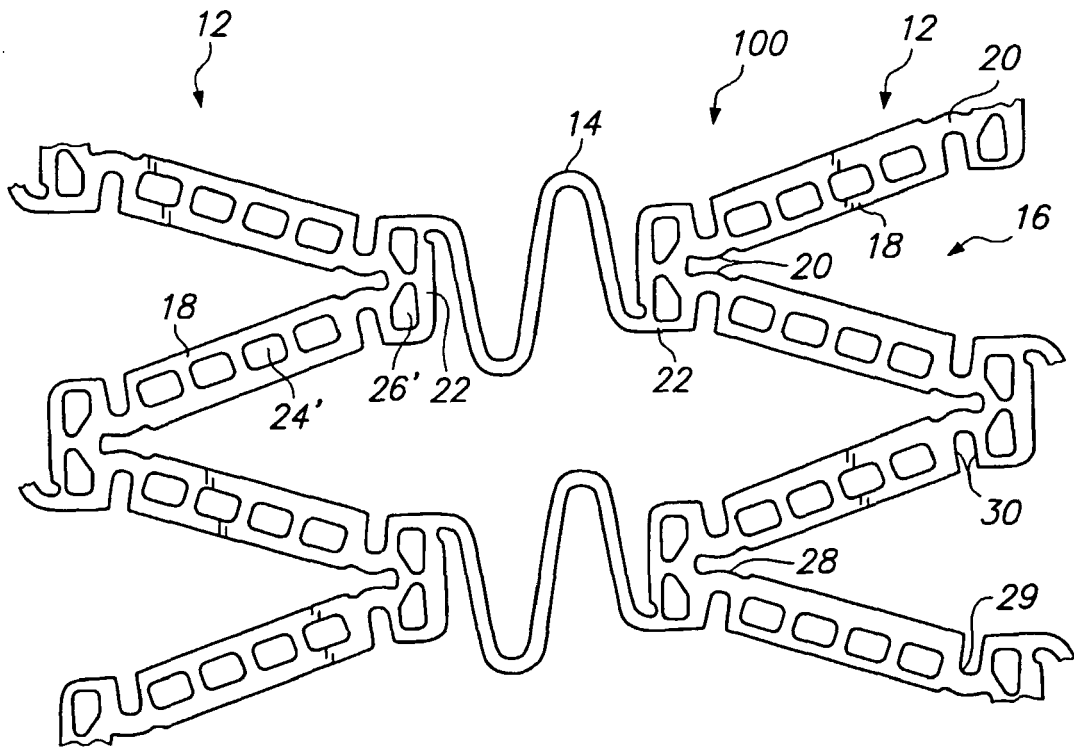

FIG. 3

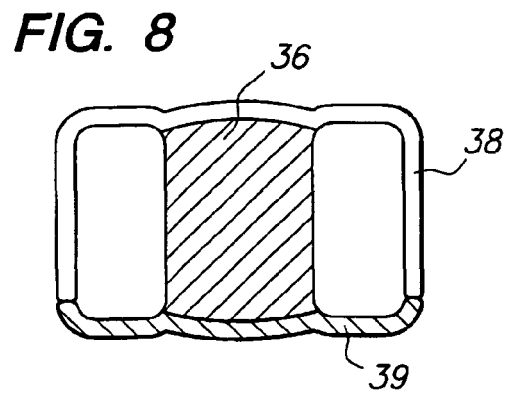
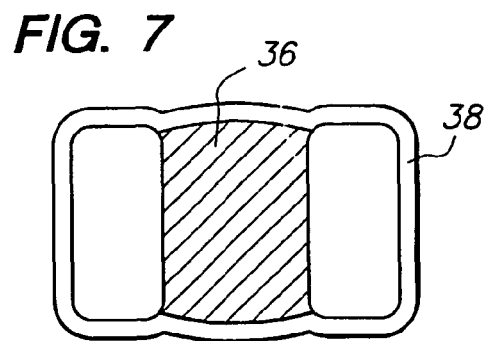
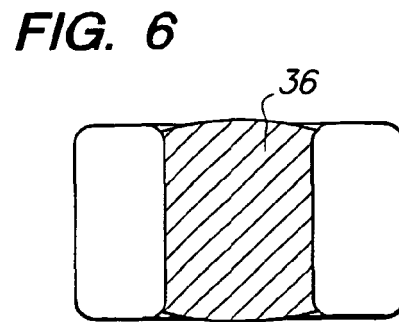
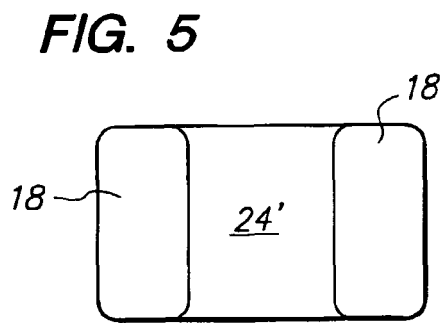
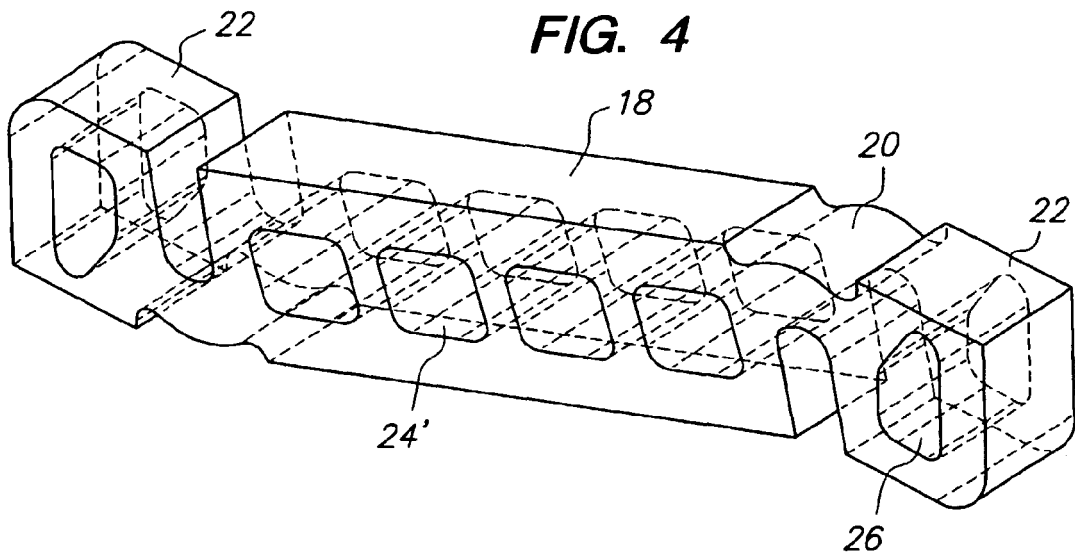

FIG. 9

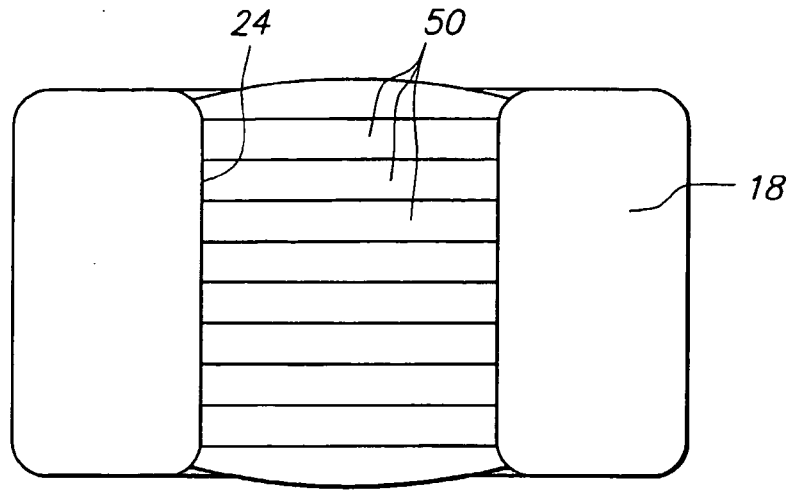

FIG. 10

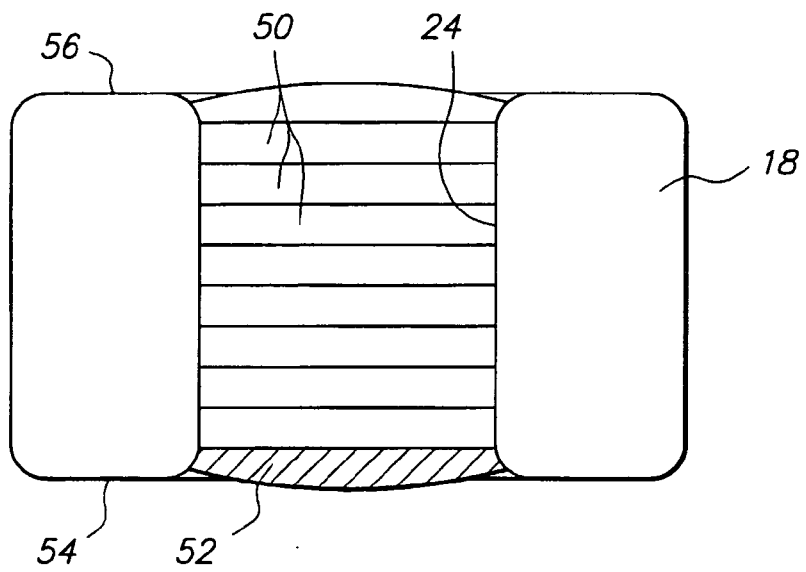

FIG. 11A

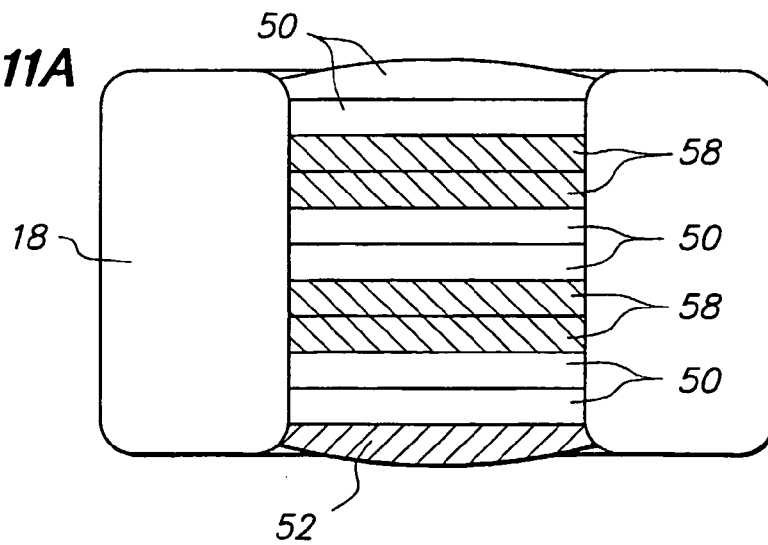

FIG. 11B

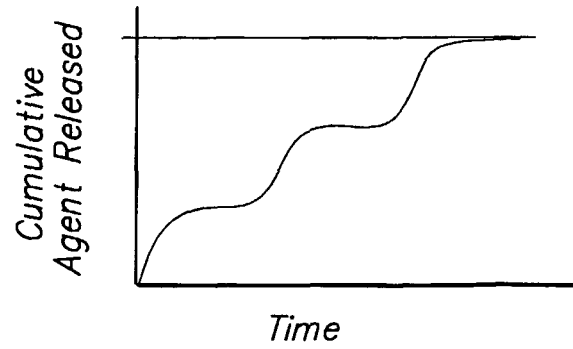

FIG. 12

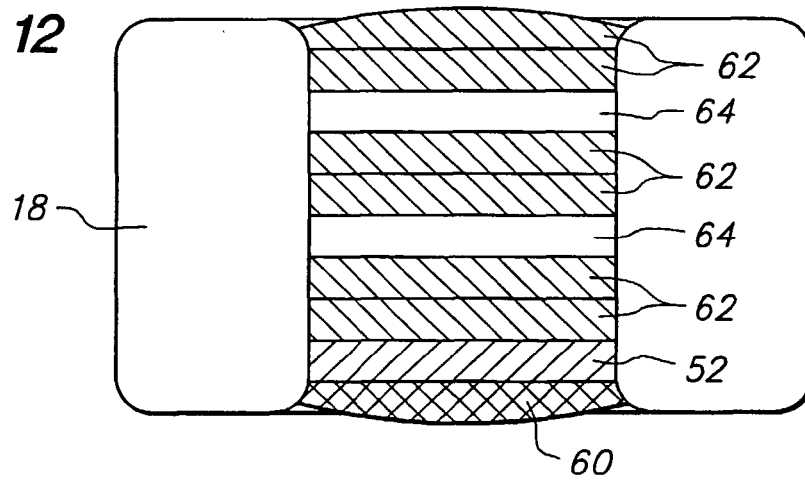

FIG. 13

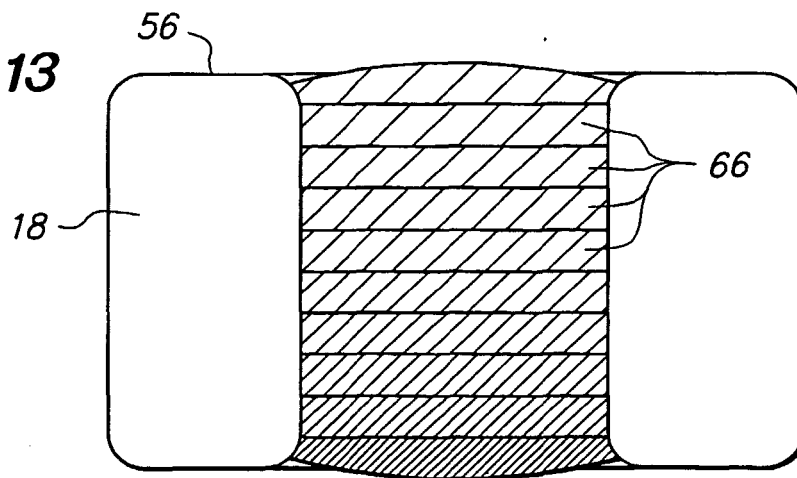

FIG. 14

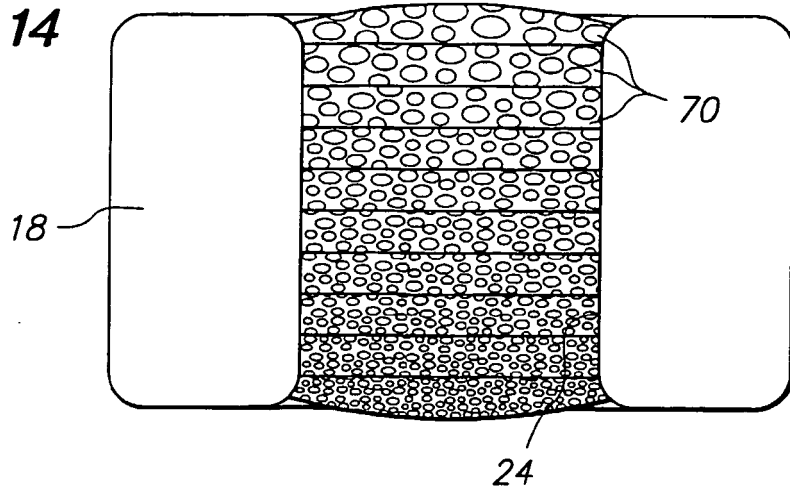

FIG. 15A

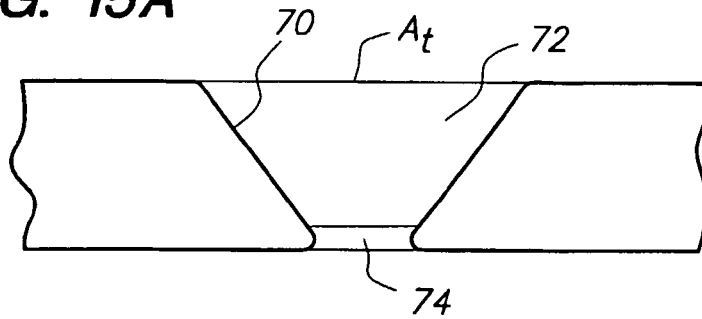

FIG. 15B

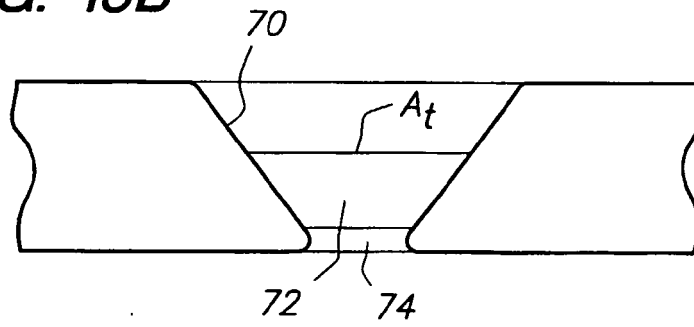

FIG. 15C

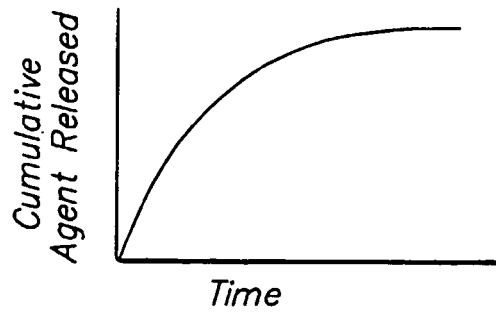

FIG. 16A

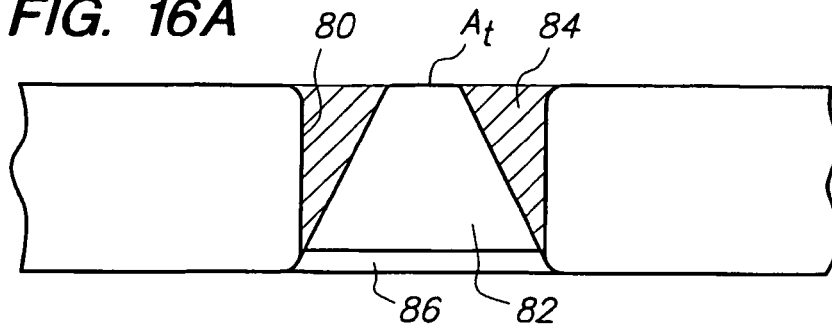

FIG. 16B

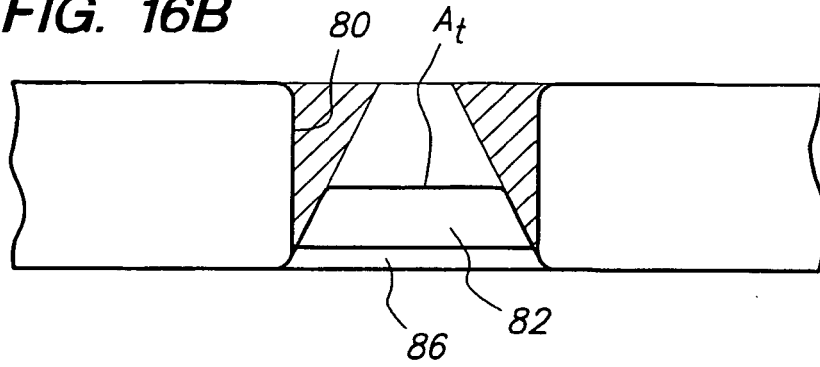

FIG. 17A

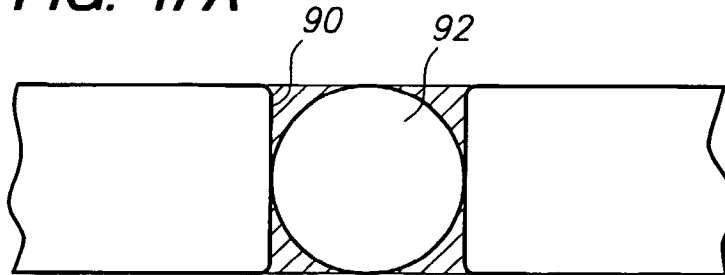

FIG. 16C

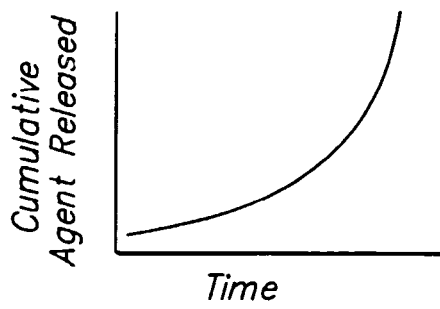

FIG. 17B

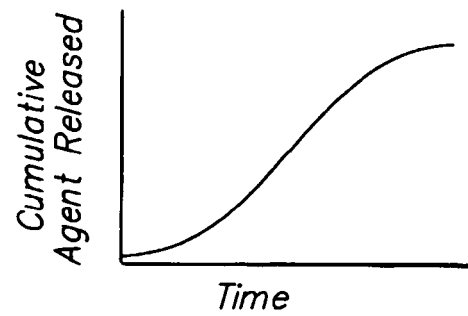

FIG. 18A

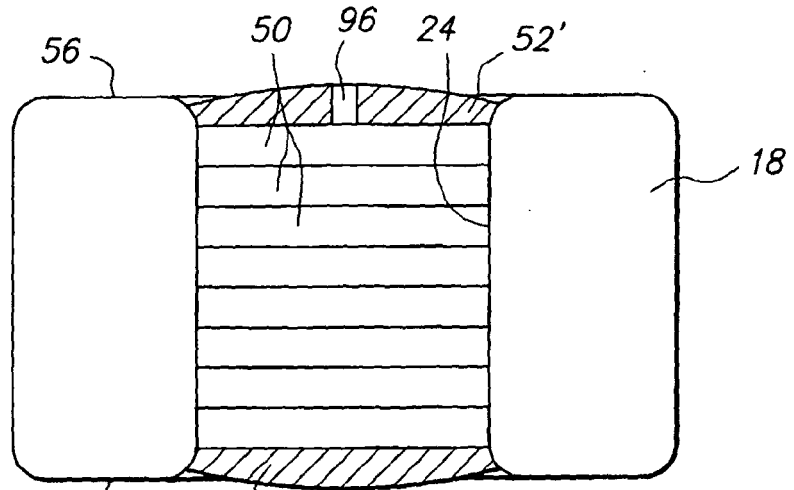

FIG. 18B

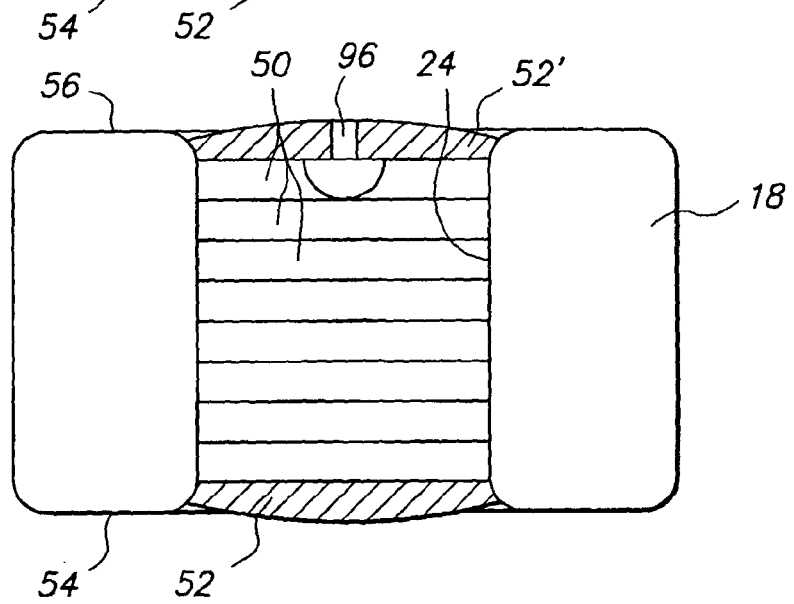

FIG. 18C

