



(12) **EUROPEAN PATENT APPLICATION**

(43) Date of publication:
09.06.2004 Bulletin 2004/24

(51) Int Cl.7: **B25B 13/46**

(21) Application number: **03020160.2**

(22) Date of filing: **05.09.2003**

(84) Designated Contracting States:
**AT BE BG CH CY CZ DE DK EE ES FI FR GB GR
HU IE IT LI LU MC NL PT RO SE SI SK TR**
Designated Extension States:
AL LT LV MK

(72) Inventor: **Chen, Terence**
Lo Tung Town, Yi Lan Hsien (TW)

(74) Representative: **Casalonga, Axel et al**
BUREAU D.A. CASALONGA - JOSSE
Paul-Heyse-Strasse 33
80336 München (DE)

(30) Priority: **03.12.2002 US 308021**

(71) Applicant: **Chen, Terence**
Lo Tung Town, Yi Lan Hsien (TW)

(54) **One-way wrench**

(57) A one-way wrench (10) includes an annular head (11), an annular gear (12), a pawl (20) and an elastic element (30). The annular head includes a circular space (13) defined therein and a crescent space (14) defined in the wall of the circular space. The annular gear is put in the circular space. The annular gear includes teeth (16) extending from an external face. The pawl is put in the crescent space. The pawl includes

teeth (21) extending from a side for engagement with the teeth of the annular gear and first, second and third protrusions (23;24;25) extending from an opposite side. The elastic element is compressed between the pawl and the wall of the crescent space. The wall of the crescent space pushes the first and second protrusions as the annular head drives the annular gear in a direction through the pawl.

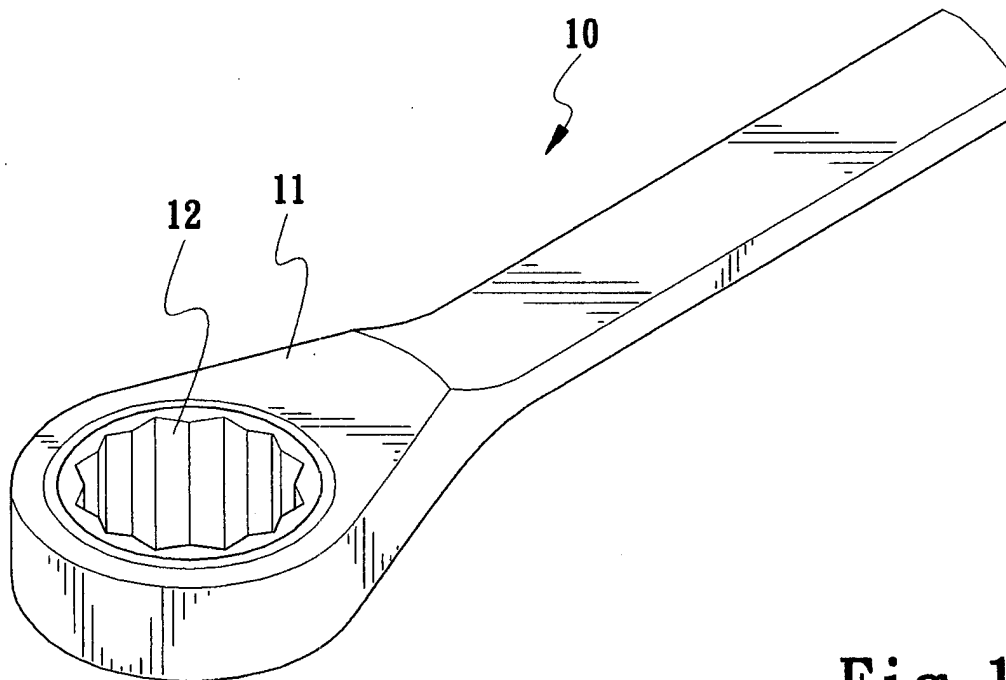

Fig. 1

Description**Field of Invention**

[0001] The present invention relates to a one-way wrench.

Background of Invention

[0002] Referring to Figure 6, a conventional one-way wrench 90 includes an annular head 91 with a circular space 92 defined therein. In the wall of the circular space 92 is defined a crescent space 94. In the wall of the crescent space 94 is defined a recess. An annular gear 93 is put in the circular space 92. The annular gear 93 includes teeth 98 formed on an external face. A pawl 95 is put in the crescent space 94. The pawl 95 includes teeth 99 formed on a side for engagement with the teeth 98 and a contact point 97 formed on an opposite side for contact with the wall of the crescent space 94. The contact point 97 is located near a left end of the pawl 95. A spring 96 includes an end fit in the recess and an opposite end connected with the pawl 95. A user can rotate the annular head 91. The wall of the crescent space 94 moves the pawl 95 clockwise. The pawl 95 rotates the annular gear 93 clockwise. The annular gear 93 rotates a bolt or nut engaged therewith. When the user pivots the annular head 91 counterclockwise, he or she moves the wall of the crescent space 94 from the pawl 95, thus allowing disengagement of the pawl 95 from the annular gear 93. Hence, the pawl 95 cannot rotate the annular gear 93 counterclockwise. That is, the user cannot rotate the bolt or nut counterclockwise with the conventional one-way wrench 90.

[0003] Figure 7 shows another conventional one-way wrench 90' similar to that of Figure 6 except for including a pawl 95' instead of the pawl 95. The pawl 95' includes a contact point 97' is located near a center thereof instead of a left end.

[0004] However, in both conventional one-way wrenches, the pawl contacts the wall of the crescent space at a single contact point. Therefore, the pawl easily wears out. Such wear causes shifting of the contact point. Such shifting causes rattling.

[0005] The present invention is therefore intended to obviate or at least alleviate the problems encountered in prior art.

Summary of Invention

[0006] It is the primary objective of the present invention to provide a robust and enduring one-way wrench.

[0007] According to the present invention, a one-way wrench includes an annular head, an annular gear, a pawl and an elastic element. The annular head includes a circular space defined therein and a crescent space defined in the wall of the circular space. The annular gear is put in the circular space. The annular gear in-

cludes teeth extending from an external face. The pawl is put in the crescent space. The pawl includes teeth extending from a side for engagement with the teeth of the annular gear and first, second and third protrusions extending from an opposite side. The elastic element is compressed between the pawl and the wall of the crescent space. The wall of the crescent space pushes the first and second protrusions as the annular head drives the annular gear in a direction through the pawl.

[0008] Other objects, advantages and novel features of the invention will become more apparent from the following detailed description in conjunction with the attached drawings.

Brief Description of Drawings

[0009] The present invention will be described via detailed illustration of the preferred embodiment referring to the drawings.

[0010] Figure 1 is a perspective view of a one-way wrench according to the preferred embodiment of the present invention.

[0011] Figure 2 is an exploded view of the one-way wrench of Figure 1.

[0012] Figure 3 is a cross-sectional view of the one-way wrench of Figure 1 pivoted counterclockwise.

[0013] Figure 4 is an enlarged partial view of the one-way wrench of Figure 3.

[0014] Figure 5 is similar to Figure 3 but showing how the one-way wrench prevents driving a bolt or nut clockwise.

[0015] Figure 6 is a top view of a conventional one-way wrench.

[0016] Figure 7 is a top view of another conventional one-way wrench.

Detailed Description of Preferred Embodiment

[0017] Referring to Figure 1, according to the preferred embodiment of the present invention, a one-way wrench 10 includes an annular head 11 and annular gear 12.

[0018] Referring to Figure 2, the annular head 11 includes a circular space 13 defined therein. In the wall of the circular space 13 is defined a crescent space 14. In the wall of the crescent space 14 is defined a hole 15.

[0019] An annular gear 12 is put in the circular space 13. The annular gear 12 includes a plurality of teeth 16 extending from an external face.

[0020] A pawl 20 is put in the crescent space 14. The pawl 20 includes a first side and a second side opposite to the first side. The pawl 20 includes teeth 21 extending from the first side for engagement with the teeth 16, a first protrusion 23 extending from the second side near a first end, a second protrusion 24 extending from the second side near a midpoint, a third protrusion 25 extending from the second side near a second end and an insert 22 extending from the second end.

[0021] In the preferred embodiment, the teeth 16 and 21 are ratchets in order to emphasize one-way rotation. In other embodiments, the teeth 16 and 21 may however be ordinary teeth.

[0022] A spring 30 includes a first end in which the insert 22 is fit and a second end put in the hole 15.

[0023] Referring to Figures 3 and 4, a user (not shown) rotates the annular head 11 clockwise. Contacting the first protrusion 23 and the second protrusion 24, the wall of the crescent space 14 pushes the pawl 20 clockwise. As the teeth 21 engage with some of the teeth 16, the pawl 20 rotates the annular gear 12 clockwise. The annular gear 12 accordingly rotates a bolt or nut in engagement therewith.

[0024] The pawl 20 contacts the wall of the crescent space 14 at two contact points, i.e., the first protrusion 23 and the second protrusion 24. Thus, the pawl 20 does not wear out easily.

[0025] Referring to Figure 5, via rotating the annular head 11 counterclockwise, the user moves the wall of the crescent space 14 from the pawl 20, thus allowing disengagement of the teeth 21 from the teeth 16. Hence, the pawl 20 cannot rotate the annular gear 12 counterclockwise. That is, the user cannot rotate the bolt or nut counterclockwise with the one-way wrench 10. In this position, the wall of the crescent space 14 is in contact with the second protrusion 24 and the third protrusion 25.

[0026] Should the teeth 21 stick to the teeth 16, as the user rotates the annular head 11 counterclockwise, the wall of the crescent space 14 pushes the third protrusion 25. Thus, the first end of the pawl 20 is lifted from the annular gear 12 as the pawl 20 is pivoted like a seesaw. Therefore, the teeth 16 can be disengaged from the teeth 21 so as to prevent the pawl 20 from driving the annular gear 12 counterclockwise.

[0027] The present invention has been described via detailed illustration of the preferred embodiment. Those skilled in the art can derive variations from the preferred embodiment without departing from the scope of the present invention. Therefore, the preferred embodiment shall not limit the scope of the present invention defined in the claims.

Claims

1. A one-way wrench (10) including:

- an annular head (11) including a circular space (13) defined therein and a crescent space (14) defined in the wall of the circular space (13);
- an annular gear (12) put in the circular space (13), the annular gear (12) including teeth (16) extending from an external face;
- a pawl (20) put in the crescent space (14), the pawl (20) including teeth (21) extending from a side for engagement with the teeth (16) of the

annular gear (12) and first, second and third protrusions (23; 24; 25) extending from an opposite side; and

- an elastic element (30) compressed between the pawl (20) and the wall of the crescent space (14);
 - wherein the wall of the crescent space (14) pushes the first and second protrusions (23; 24) as the annular head (11) drives the annular gear (12) in a direction through the pawl (20).
2. The one-way wrench (10) according to claim 1 wherein the wall of the crescent space (14) can push the third protrusion (34) so as to pivot the pawl (20) from the annular gear (12) as the annular head (11) rotates relative to the annular gear (12) in an opposite direction.
 3. The one-way wrench (10) according to claim 1 wherein the annular gear (12) includes teeth (21) extending from an internal face.
 4. The one-way wrench (10) according to claim 1 wherein the all the teeth (22; 31) are ratchets.
 5. The one-way wrench (10) according to claim 1 wherein the annular head (11) includes a hole (15) defined in the wall of the crescent space (14) for receiving the elastic element (30).
 6. The one-way wrench (10) according to claim 1 wherein the elastic element (30) is a spring.
 7. The one-way wrench (10) according to claim 6 wherein the spring (30) is a helical spring.
 8. The one-way wrench (10) according to claim 7 wherein the pawl (20) includes an insert (22) extending into the helical spring (30).
 9. The one-way wrench (10) according to claim 1 wherein the wall of the crescent space (14) pushes the third protrusion (25) so as to pivot the pawl (20) from the annular gear (12) as the annular head (11) rotates relative to the annular gear (12) in an opposite direction.

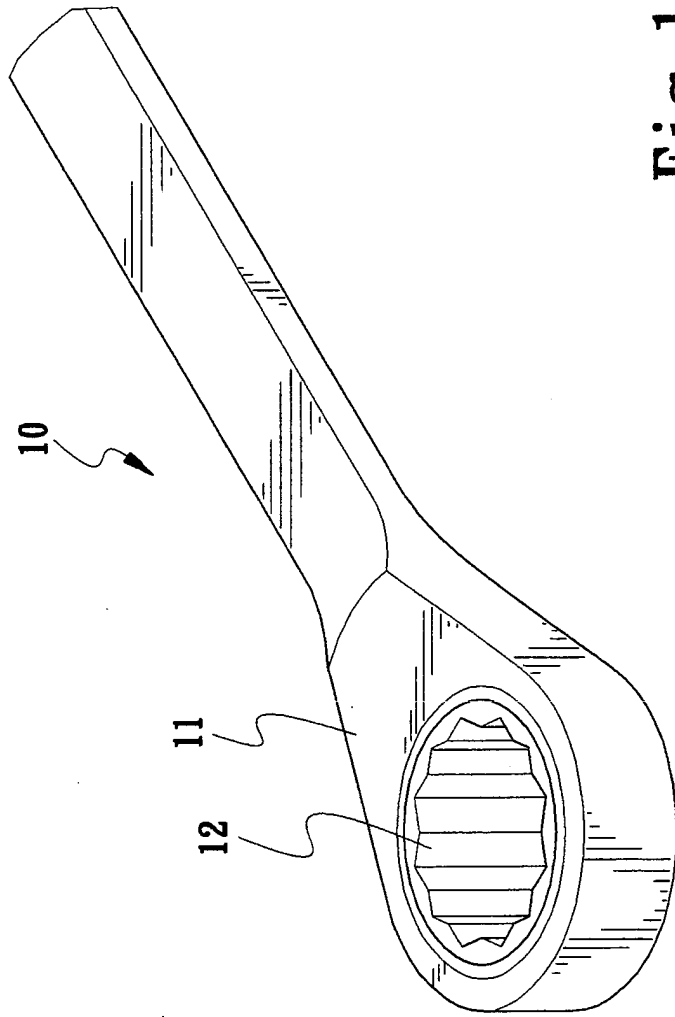

Fig. 1

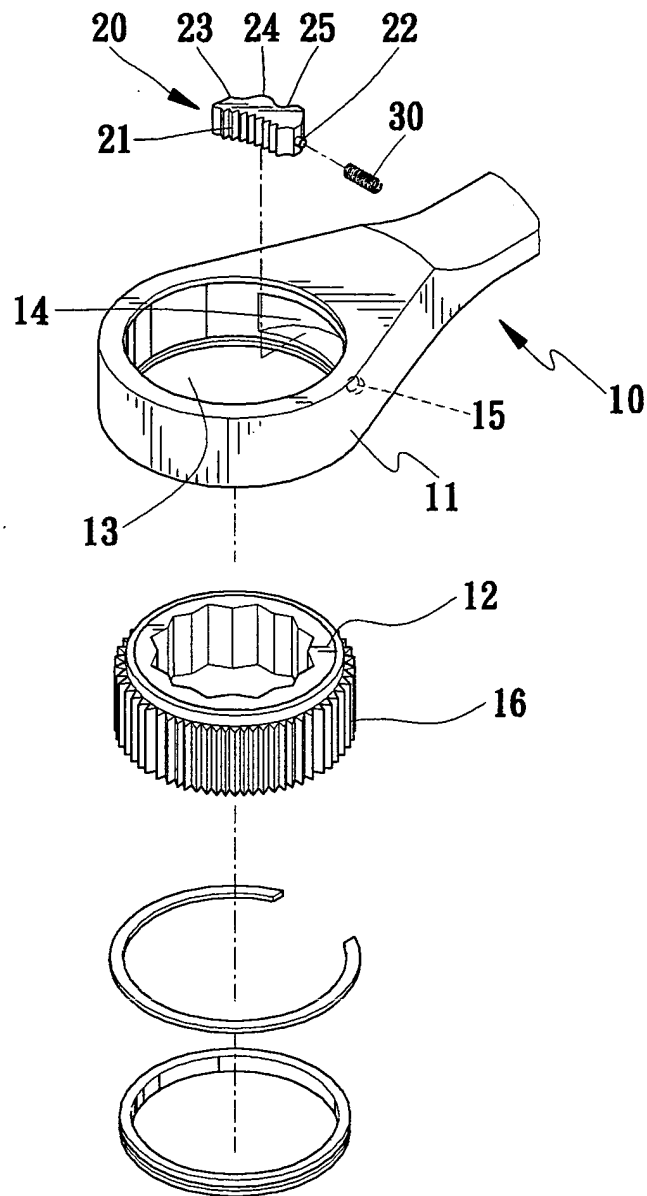

Fig. 2

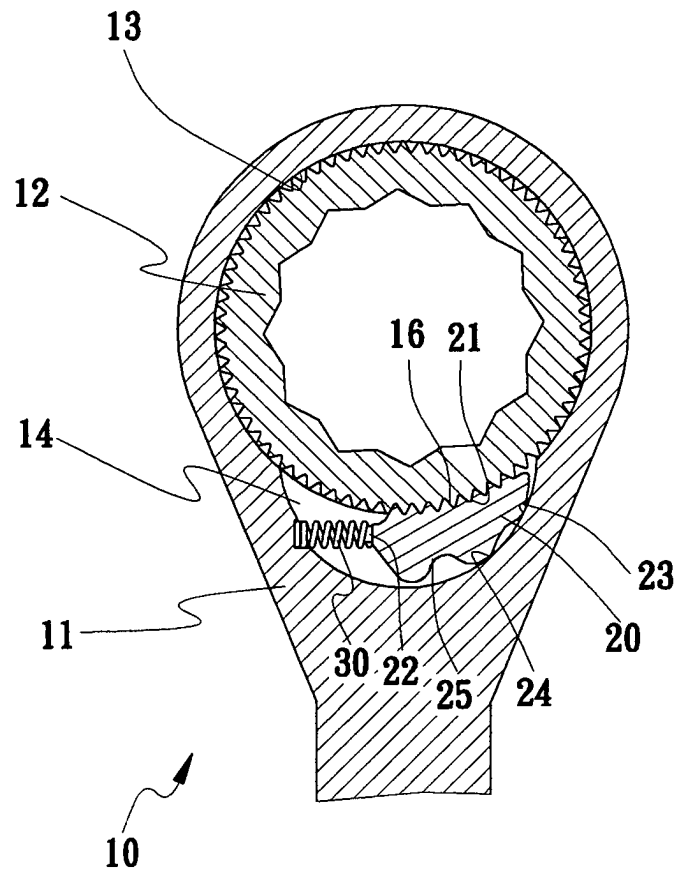

Fig. 3

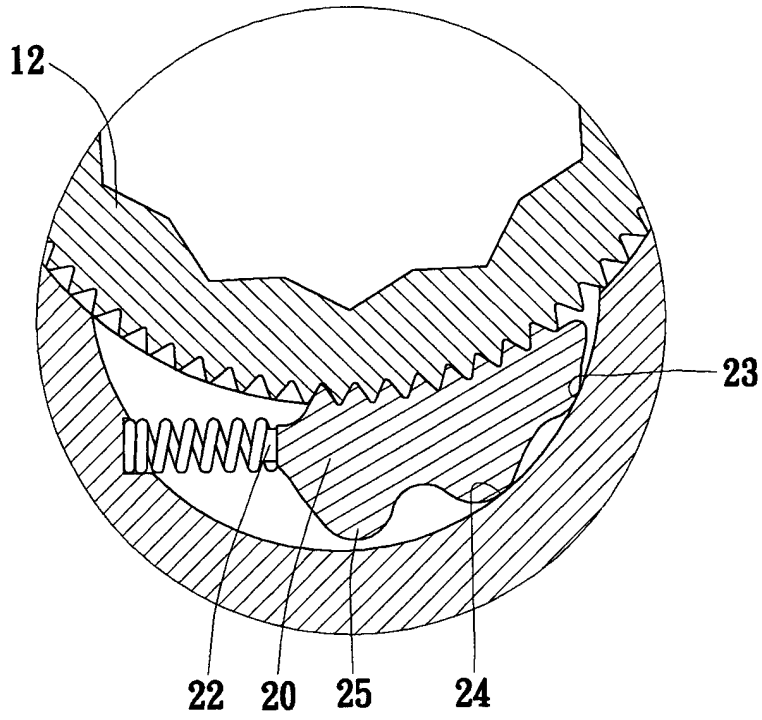

Fig. 4

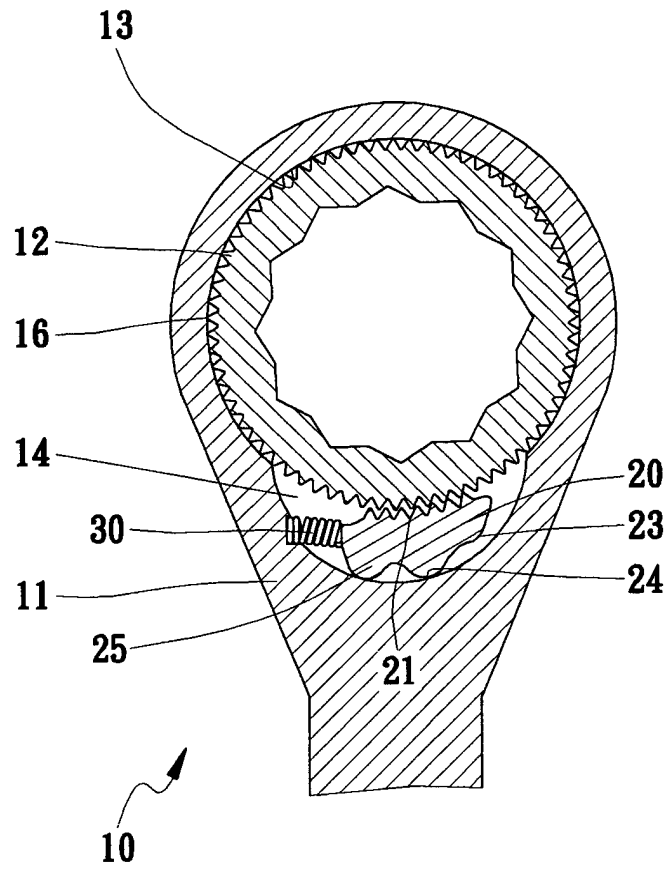

Fig. 5

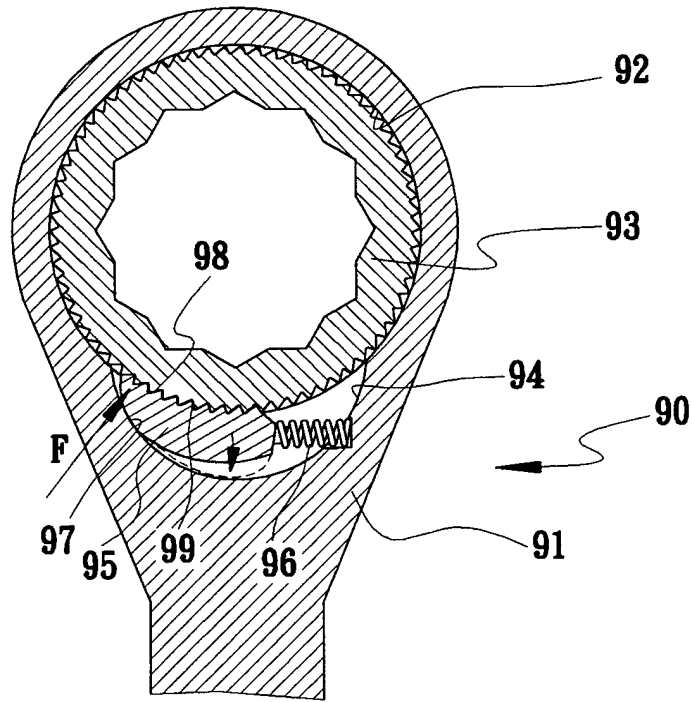

Fig. 6
PRIOR ART

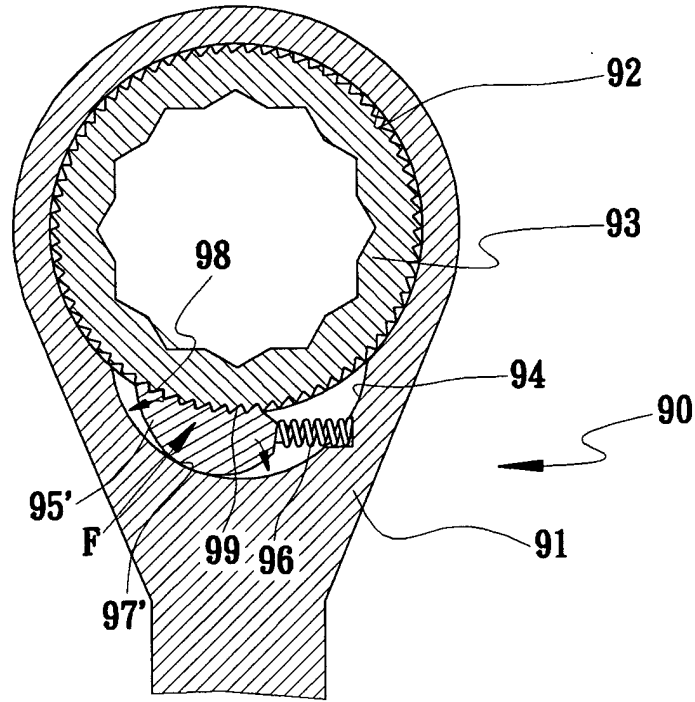

Fig. 7
PRIOR ART



European Patent
Office

EUROPEAN SEARCH REPORT

Application Number
EP 03 02 0160

DOCUMENTS CONSIDERED TO BE RELEVANT			
Category	Citation of document with indication, where appropriate, of relevant passages	Relevant to claim	CLASSIFICATION OF THE APPLICATION (Int.CI.7)
X	US 6 450 066 B1 (HU BOBBY) 17 September 2002 (2002-09-17)	1,3-7	B25B13/46
Y	* figures 14-16 *	8	
Y	--- US 6 148 695 A (HU BOBBY) 21 November 2000 (2000-11-21) * figures 4,7A *	8	
A	--- DE 200 01 237 U (HUNG KUN CHIH ;LEE WAN CHUAN (TW)) 27 April 2000 (2000-04-27) * figures 2-6 *	1,8	
A	--- US 6 164 167 A (CHEN YU-TANG) 26 December 2000 (2000-12-26) * figure 1 *	1	
A	--- DE 202 00 403 U (CHEN MU LIN) 16 May 2002 (2002-05-16) * figures 1-14,16,18 *	1	
			TECHNICAL FIELDS SEARCHED (Int.CI.7)
			B25B
The present search report has been drawn up for all claims			
Place of search		Date of completion of the search	Examiner
THE HAGUE		15 March 2004	Carmichael, Guy
CATEGORY OF CITED DOCUMENTS			
X : particularly relevant if taken alone		T : theory or principle underlying the invention	
Y : particularly relevant if combined with another document of the same category		E : earlier patent document, but published on, or after the filing date	
A : technological background		D : document cited in the application	
O : non-written disclosure		L : document cited for other reasons	
P : intermediate document		& : member of the same patent family, corresponding document	

EPO FORM 1503 03/82 (P04C01)

**ANNEX TO THE EUROPEAN SEARCH REPORT
ON EUROPEAN PATENT APPLICATION NO.**

EP 03 02 0160

This annex lists the patent family members relating to the patent documents cited in the above-mentioned European search report. The members are as contained in the European Patent Office EDP file on The European Patent Office is in no way liable for these particulars which are merely given for the purpose of information.

15-03-2004

Patent document cited in search report		Publication date	Patent family member(s)	Publication date
US 6450066	B1	17-09-2002	NONE	
US 6148695	A	21-11-2000	CA 2313397 A1 EP 1074348 A2 US 6301998 B1	03-02-2001 07-02-2001 16-10-2001
DE 20001237	U	27-04-2000	DE 20001237 U1	27-04-2000
US 6164167	A	26-12-2000	NONE	
DE 20200403	U	16-05-2002	DE 20200403 U1	16-05-2002

EPC FORM P0459

For more details about this annex : see Official Journal of the European Patent Office, No. 12/82