



(12) **EUROPEAN PATENT APPLICATION**

(43) Date of publication:
09.06.2004 Bulletin 2004/24

(51) Int Cl.7: **B65B 11/02**

(21) Application number: **03027074.8**

(22) Date of filing: **25.11.2003**

(84) Designated Contracting States:
**AT BE BG CH CY CZ DE DK EE ES FI FR GB GR
HU IE IT LI LU MC NL PT RO SE SI SK TR**
Designated Extension States:
AL LT LV MK

(72) Inventor: **Pieri, Danica**
47023 Cesena (IT)

(74) Representative: **Porsia, Dino, Dr.**
c/o Succ. Ing. Fischetti & Weber
Via Caffaro 3/2
16124 Genova (IT)

(30) Priority: **02.12.2002 IT BO20020755**

(71) Applicant: **PIERI S.r.l.**
47020 Pievesestina di Cesena (IT)

(54) **Apparatus for the fastening of the tail of wrappings of stretchable film for palletized goods**

(57) The apparatus comprises:

- a straight counter-rod (4) which during the final stage of the wrapping cycle is raised, arranged vertically and brought up alongside the bottom part of the load, at the correct distance from the latter, so as to ensure that at least the last turn of the wrapping rests on this rod so as to create in the side and bottom part of the said wrapping a pocket (S) of suitable amplitude which is open both upwards and downwards and inside which a portion of the said last turn is sufficiently spaced from the load;
- means for stopping the wrapping machine when the tail end of the wrapping, which is wholly or partly overlapped by the turn forming the pocket, is at a small distance or touches the said pocket (S) with the associated internal forming rod (4);
- means (21, 24) for transversely compressing into a bundle at least one section of the tail end of the wrapping, and a secondary gripper (321) and a primary gripper (22) for retaining successive portions of the said bundle of film;
- means (23) for cutting the section of film along the section comprised between the said two grippers (321, 22) so as to define the tail end of the wrapping (X) which is retained by the secondary gripper (321) and the front end (Y) of the future wrapping which is retained by the main gripper (22);
- means for inserting the secondary gripper (321) with the tail end of the wrapping into the said pocket (S), with insertion from the top part of the said pocket, and means being envisaged for opening this gripper and for extracting it from the pocket and bringing it back into the rest position;

- means which extract from the bottom part of the pocket the rod (4) which formed it, bringing this rod into the rest position such that, owing to the elastic memory effect of the wrapping film, the pocket is closed.

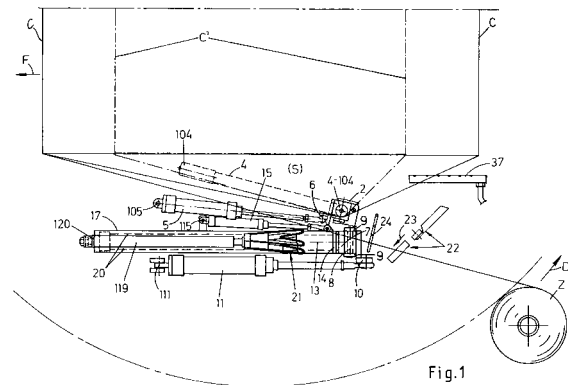

Fig.1

Description

[0001] The invention relates to an apparatus particularly suitable for rotating-arm or rotating-load wrapping machines, for fixing, without welding, the tail end of the wrappings of palletized loads, formed using stretch film and/or other elastic or plastic material. The Applicant is the owner of the United States patent described in the document US 6 453 643 B1 which describes a method for performing the said mechanical fixing of the tail end of the wrapping formed with wrapping machines of any type and characterized by the sequence of following operating steps:

- during the final stages of the wrapping cycle, a straight and vertical counter means is brought up to a wall of the load, at the correct distance from it, and the last turn or turns of the wrapping cycle are rested on it so as to create in the said wrapping a pocket of suitable amplitude in which the said last turns are sufficiently spaced from the load;
- the tail end of the wrapping is transversely compressed into a bundle and the bundle of film is retained by a main gripper and a secondary gripper which are situated at a small distance from each other, the secondary gripper being situated closer to the load;
- the bundle of film is cut along the section comprised between the said two grippers so as to define the tail end of the wrapping which is retained by the secondary gripper and the front end of the next wrapping which is retained by the main gripper;
- the secondary gripper with the tail end of the wrapping is inserted into the said pocket formed during the first stage of the cycle in question, following which this gripper is opened and extracted from the pocket, while in synchronism, from the said pocket, extraction of the said counter means which initially formed it is effected so that, owing to the elastic memory effect of the wrapping film, the pocket rapidly closes and firmly retains inside it the tail end of the wrapping, without the need for performing conventional heat-welding and without leaving in the wrapping projecting parts which could be interpreted as imperfections in the formation of the said wrapping by quality control means often operating along the unloading line of a wrapping machine.

[0002] The patent mentioned in the introduction describes and illustrates an apparatus which implements the aforementioned method which is however particularly suitable for ring wrapping machines. The invention intends to protect an apparatus which fundamentally also implements the aforementioned method which is however suitable for rotating-arm or rotating-pallet wrapping machines.

[0003] The characteristic features of the apparatus in question and the advantages arising therefrom will be-

come obvious from the following description of a preferred embodiment thereof, illustrated purely by way of a non-limiting example in the figures of the accompanying illustrative plates in which:

- 5 - Figs 1 and 2 are respectively a plan view and side elevation view of the main components of the apparatus during the first stages of the processing cycle;
- 10 - Fig. 3 is a side view as can be seen in Figure 2, which shows more clearly the movement means of the main operating components of the apparatus in question;
- 15 - Fig. 4 shows a front elevation view, with parts sectioned, of the components shown in Figure 3;
- Fig. 5 shows a perspective view of the movable gripper of the apparatus;
- Figs 6 and 7 show a top plan view of the apparatus during the steps involving gripping of the tail end of the wrapping by the secondary gripper and intervention of the main gripper of the means which cut the film situated between the two grippers and which prepare the secondary gripper for insertion of the tail end of the wrapping into the pocket created in the said wrapping by the appropriate means;
- 20 - Figs 8 and 9 show a front elevation view, during the steps of Figure 7, of insertion of the secondary gripper into the pocket of the wrapping during the subsequent return movement upwards and during the final step of neutralization of the pocket forming means, with closing of the said pocket and fixing of the tail end of the wrapping;
- 25 - Figs 10 and 11 show respectively a side and top perspective view of the primary gripper with the associated cutting means;
- Fig. 12 is a top plan view of a variant of the means which perform rotation of the secondary gripper about an axis parallel to the longitudinal axis of the said gripper.
- 30
- 35
- 40

[0004] In Figure 1, C, C' denote respectively in continuous lines and broken lines the loads of different sizes which may be processed by the wrapping machine which for the moment is assumed to be of the rotating-arm type. The load is positioned underneath the gantry of the machine, in the correct wrapping position, by a parallel-chain or motorized-roller conveyor T, as in the example in question. The direction of travel of the product is preferably that indicated by the arrow F (see below), but may also be in the opposite direction.

[0005] Laterally with respect to the conveyor T, fixed to one of the sides of the said conveyor or fixed on the ground or to one side of the stationary load in the wrapping station, any suitable frame 1 is provided, the said frame supporting the various components of the apparatus in question, which, when in the rest position, must not interfere with the bottom edge B of the wrapping A formed by means of unwinding of the film from the reel

Z mounted so as to be able to be raised and lowered on the upright of the arm in the form of an overturned L of the wrapping machine, known and not shown, which rotates about a vertical axis substantially coinciding with the centre of the load C or C'. D denotes the direction of rotation, about the load, of the reel Z. In Figure 2, the operating means of the apparatus have been shown in broken lines when they are in the rest position indicated by the arrow K and it may be noted how the said means are all located at a height lower than the edge B of the wrapping. With reference to Figures 1 to 4 it can be seen how the apparatus comprises on the top of the frame 1 a support 2, for example in the form of a fork member, which is able to rotate about its vertical axis 102 and which comprises means so that it can be fixed with a correct orientation during installation of the said apparatus. The support 2 pivotably supports on a horizontal shaft 3 the bottom end of the counter-rod 4 which usually has a round cross section and a length proportional to the height of the turns of the load wrapping film (see below) and is preferably provided on its free end with a roller 104 in the form of a cap, with a rounded top end, which is rotatably fitted over a top section of the said rod and which rotates idly about an axis coinciding with the longitudinal axis of the said rod 4. The pivoting shaft 3 of the rod 4 or the rod itself is connected to a pivoting actuator which must bring this rod from the horizontal, lowered, rest position into the vertical, raised, working position and vice versa and which for example comprises a fluid pressure cylinder 5 which is secured with the base of its body at 105 to the support frame 1 and hinged with the end of its stem to a lever 6 fixed at right angles for example on one end of the said shaft 3. Suitable means, not shown, may be envisaged for damping and stopping the end-of-travel strokes of the actuator 5 and/or the lever 6 so as to keep the rod 4 stable in the two different positions, all of which in a manner which can be deduced and easily realized by persons skilled in the art. When the rod 4 is in the horizontal, lowered, rest position, as indicated by broken lines in Figure 1, the said rod is oriented in the direction of the plan projection of the load C, C', is situated underneath the ideal horizontal plane which contains the bottom edge B of the wrapping and is such as not to interfere with the said load, with the pallet P, with the conveyor T or with the associated base. When the load has been wrapped, the rod 4 is raised vertically as shown in continuous lines in Figures 1 and 2 and in this position the said rod is located at a suitable distance from the load and is such as to support at least one last turn of the wrapping so as to form therewith a pocket S of suitable amplitude. The last turn of the film for wrapping the load may be provided with a height which if appropriate is lower than that of the other turns, owing to the intervention of means which operate, for example, on the carriage of the wrapping machine with the reel Z. This possible condition would allow a notable constructional and functional simplification of the apparatus in question as will be understood

further below.

[0006] Still with reference to Figures 1 to 4, it can be seen that laterally with respect to the counter-rod 4, in a position such as to be located on the outside of the pocket S formed in the wrapping by the said rod, a plate 7 is provided, the said plate being pivotably mounted at one of its ends on a horizontal shaft 8 perpendicular to the direction of travel of the product on the conveyor T and supported at its ends by a pair of support brackets 9 fixed to the aforementioned structure 1. One end of the shaft 8 projects from the associated support bracket 9 and has, fixed thereto, a right-angled lever 10 which is hinged for example with the stem of a fluid pressure cylinder 11 which is secured at 111 to support brackets fixed to the frame 1. By means of the actuator 11, the plate 7 may be brought from the vertical rest position oriented downwards, into the horizontal active position, as illustrated by means of broken lines and continuous lines in Figures 2 and 3. Special damping and end-of-travel means are envisaged for stopping the plate correctly in the said limit positions. In Figure 3, 12 for example denotes a stop integral with the frame 1, for stopping the plate 7 in the horizontal active position. The plate 7 has, rotatably mounted thereon, about a shaft 13 perpendicular to the said plate a further plate 14 provided for example laterally with an appended part 114 hinged with the stem of a fluid pressure cylinder 15 which, with its body, is hinged at 115 with an arm 107 integrally joined in cantilever fashion to and coplanar with the plate 7. By means of the actuator 15, the plate 14 may be brought from the rest position where it is aligned with the underlying plate 7, as illustrated in Figures 1 to 4, into a position rotated through 90 with respect to this plate (Fig. 7), and in this case also special damping and end-of-travel means are envisaged for stopping the plate 14 in the two different positions. In Figure 4, 16 denotes for example a stop integral with the plate 7 and useful for stopping the plate 14 in the rest position. The rotation of the plate 14 about the shaft 13 may be performed using means different from those described above, for example using means located even underneath the primary plate 7 and comprising a rack-and-pinion assembly 113 with the associated fluid pressure cylinder 15' for alternately actuating the rack. This solution is more suitable than the previous solution for varying, according to requirements, the rotational amplitude of the plate 14 and in particular involves volumes with a smaller projection relative to the pivoting fulcrum 8 and situated underneath this fulcrum and the associated primary plate 7 so as to form a substantial counterweight for the operating means mounted on the secondary plate 14, with advantages also of the dynamic type, as will appear more clearly in the remainder of the description.

[0007] The plate 14 has fixed, perpendicularly with respect thereto, a straight guide 17, for example of the tubular type, with a polygonal cross section and height slightly greater than the height of the turns forming the

pocket S, inside which there slides, with the aid of means having a low coefficient of friction, for example ball bearings or lateral rollers 18 (Fig. 2), a rod-shaped slide 19 which may be extended or retracted by means of a fluid pressure cylinder 20 also fixed via its body onto the plate 14 and integral, via its stem, with a lateral and upper appended part 120 of the said slide, which supports rigidly and with the possibility of adjustment along perpendicular axes an arm 119 which is in the form of an overturned L having a section which is parallel to and arranged alongside the said slide 19 and on the bottom of which an assembly 21, more clearly illustrated in Figure 5, is mounted. From this figure it can be seen that the assembly 21 comprises a body 121 which is fixed onto the bottom end of the arm 119 with the possibility of being oriented in the correct position with rotation about the longitudinal axis of the said arm and being able to be locked in the most suitable position. In the example in question, the body 121 has two flat and facing surfaces, with longitudinal grooves inside which the ends of a pair of fork members 221 are inserted and fixed using suitable means, the said fork members being formed for example by a round metal bar, diverging downwards and being identical and parallel to each other. The body 121 carries, hinged at the bottom, the pair of jaws 321 of a secondary gripper, which are actuated with a symmetrical movement by a stem which slides axially inside the said body 121 designed to function also as a fluid pressure cylinder. When the jaws 321 are in the open position, their active and preferably toothed surface is raised with respect to the internal overturned V-shaped part of the fork members 221, whereas, when they are closed, the said jaws project from this V-shaped part of the fork members and are arranged in the middle of the latter so as to grip the material gathered in this same V-shaped part (see below).

[0008] When the apparatus is in the horizontal rest position, the assembly 17, 19, 119 lies in a vertical ideal plane and is in the contracted position. After formation of the pocket S, the machine stops with the arm which carries the reel Z in a predetermined and constant angular position (Fig. 1), with the last section of the film connected to the said reel, namely the tail end of the wrapping, situated at a short distance from the counter-rod 4 which has formed the said pocket S and which for this reason is located in the correct position for gripping by the unit 21, as described further below. In synchronized sequence the cylinder 11 is retractably actuated so as to raise the plate 7 with rotation through 90 until it is arranged horizontally and during this step the cylinder 20 is actuated extendably so as to extend the assembly 17, 19, 119 with the unit 21, so that, at the end of this step, the said assembly is in a vertical position, with the unit 21 raised and above the tail end of the wrapping, as shown in broken lines in Figure 2 and as shown in Figure 6. From these same figures it can be seen that, in synchronized sequence, the assembly 19, 119 is lowered with retraction of the cylinder 20 so that the pair of

fork members 221 moves down onto the tail end of the film and bundles it together along its bottom edge B, as shown with continuous lines in Figure 2, and at the end of this step, closing of the jaws 321 is performed so that the secondary gripper situated on the unit 21 retains the tail end of the wrapping.

[0009] At a short distance from the unit 21, the bottom edge B of the tail end of the wrapping is supported by a counter-guide 24 which is for example fixed to the frame 1 (Figs 2, 6).

[0010] At this point it is obvious that, if the tail end of the film were conditioned beforehand by means on the arm of the wrapping machine, which restrict it transversely in a symmetrical manner, the downward stroke of the unit 21 would be shorter than that shown in Figure 2. This same result could be obtained, as an alternative to that stated above, by providing, longitudinally sliding on the guide 17, a means (not shown) which normally is in the bottom part of this guide and, when the latter is raised, is arranged underneath the tail end of the film and which, via associated means, may be raised while the unit 21 is lowered, so that bundling of the tail end inside the fork member 221 is performed with a smaller or minimum downwards stroke of the unit 21. According to another embodiment, similar advantages could be obtained by associating with raising and lowering means the aforementioned counter-guide 24 which was assumed to be fixed to the frame 1.

[0011] Following closing of the jaws 321 of the secondary gripper, it is envisaged closing at a short distance from the latter, onto the section of film situated between the said secondary gripper and the reel of film Z, a primary gripper 22 which is also mounted for example on the frame 1 and which, as shown in the detail of Figures 10 and 11, comprises a jaw 122 which is fixed to the said frame, situated underneath and transversely with respect to the bottom edge B of the said section of film and comprises a movable jaw 222 which, with one of its ends, is for example fixed laterally with respect to a pinion 25 located at the end of the jaw 122 which is directed towards the load C and means are envisaged for alternate rotation of the said pinion, so that the movable jaw 222 passes from the horizontal removed position longitudinally aligned with the jaw 122, as shown in Figure 11 by broken lines, into the closed position where it is arranged on top of the fixed jaw, as shown in Figures 11 and 12 in continuous lines. For this purpose the pinion 25 meshes for example with a larger-diameter pinion 27, the shaft 127 of which is also rotatably supported by the plate 26 and this pinion is used as a crank, being hinged at 28 with the stem of a double-acting pneumatic cylinder 29 in turn hinged, via its body, at 30 with a support arm 126 integral with the said plate 26 and fixed to the frame 1. From Figure 10 it can be seen how the assembly of the primary gripper 22 is substantially horizontal, with a slight gradually upward inclination in the direction of the load, in order to avoid damaging interference between the fixed jaw 122 and the bottom edge B of the

tail end of the wrapping film. Following closing of the jaw 222 onto the jaw 122, the gripper 22 retains the section of film which will form the front end Y of the future wrapping performed by the wrapping machine. According to a further constructional variant of the apparatus, it may be envisaged that the aforementioned action of bundling together upwards the tail end of the wrapping may be performed, as an alternative to the solutions already mentioned, by the same primary gripper 22 which, before closing, is made to perform a raising movement suitable for the abovementioned objects.

[0012] The primary gripper 22, on the side thereof directed towards the secondary gripper 321, is provided with cutting means 23 consisting for example of a blade with sawteeth, directed upwards and integral with a carriage 31 (Figs 10, 11) which slides inside a tubular guide 32 parallel to the fixed jaw 122 and also fixed for example to the said plate 26. This guide houses internally and has hinged therewith at 34, via its body, the double-acting pneumatic cylinder 33 connected via its stem to the said carriage 31 with the saw 23 which projects from the guide 32 through a longitudinal window 132 and which, in the rest position, is protected inside a bridge-piece 35. After closing of the primary gripper 22, the blade 23 is moved away from the load, as shown in Figure 11, and interferes with the section of film which lies between this gripper and the secondary gripper of the unit 21, so as to separate the tail end X of the wrapping retained by the said secondary gripper 321, from the front end Y of the future wrapping which is retained by the said primary gripper 22. In strict synchronized sequence the blade 23 returns into the rest position underneath the bridge-piece 35.

[0013] The cylinder 15 is activated in synchronized sequence and causes rotation, through ninety degrees, of the assembly 21 with the secondary gripper about its vertical axis and in the direction of the wrapped load, as illustrated in Figures 7 and 8, so that the said secondary gripper 321 is positioned above the pocket S. In synchronized sequence the cylinder 20 is retractably actuated so as to insert the secondary gripper into the pocket S, as shown by broken lines in Figure 8. At this point it must be pointed out that, if the downward stroke of the secondary gripper outside the pocket S, for gripping the tail end of the film, were shorter than that shown in Figure 2, owing to the presence of the already mentioned alternative solutions, the downward stroke of the said secondary gripper inside the pocket would be shorter than that shown in Figure 8. It must be pointed out, however, if necessary, that it will be possible to vary the magnitude of the two different downward strokes of the secondary gripper 321, outside and inside the pocket S, using on the body of the cylinder 20 special reed-type sensors which are actuated by a permanent magnet located in the piston of this cylinder or using, instead of the single cylinder 20, two cylinders arranged one after the other and designed for simultaneous or selective actuation.

[0014] Following insertion of the secondary gripper in-

to the pocket S, with consequent insertion of the tail end of the wrapping inside it, the secondary gripper 321 is opened and then the entire assembly 21 is raised as shown in continuous lines in Figure 9, while in strict synchronized sequence the counter-rod 4 is lowered and extracted from the pocket S which closes owing to the elastic effect of the wrapping film and firmly retains inside it the tail end X of the said wrapping. From the sequence shown in Figures 8 and 9 it can be seen how extraction of the assembly 21 with the secondary gripper from the pocket S is facilitated by the presence, integral with the arm 119, of a sliding shoe 36 which prevents damaging interference between the turn which forms the said pocket, after the rod 4 has moved away, and the said assembly 21.

[0015] In synchronized sequence the assembly 17, 19, 119 with the secondary gripper 321 rotates through ninety degrees, as indicated by broken lines in Figure 9, and then the whole assembly is retractably actuated and at the same time rotated through ninety degrees downwards and brought back into the start of cycle condition.

[0016] If the wrapped load is removed from the wrapping machine in the direction of the arrow F in Figure 1, the same load may commence the removal movement in synchronism with lowering of the rod 4. Otherwise, once lowering of the rod 4 has been completed, the load is removed from the wrapping station and is replaced by a new load. The primary gripper 22 remains temporarily in the active state in which it was left with reference to Figure 7, and the arm with the reel Z starts to rotate about the load, remaining temporarily at the bottom with the said reel and before the latter performs a complete rotation, the said primary gripper 22 opens and a static blower bar 37 (Fig. 1) situated between this gripper and the load is activated, the said bar with an ascending jet of air pushing against the load C the front end Y of the wrapping film previously retained by the said gripper 22, so that this front end is fully overlapped by the first turn of the said wrapping film, remaining completely incorporated within the said wrapping which is thus correctly formed also during the initial steps. If necessary, alternative means may be envisaged for ensuring that, at the start of each working cycle, the primary gripper 22 pivots closed in the direction of the load so as to move the front end of the film towards the latter and then the upper jaw of the jaws of the said gripper rotates 180 so as to open with respect to the other jaw which remains in its existing position, while in synchronism the said blowing means are activated so as to push the front end of the wrapping against the load. It is understood that opening of the primary gripper may be activated after the first revolution of the reel Z, so that the front end of the wrapping is trapped between the first and the second turn of the said wrapping. It is understood that the apparatus described here for rotating-arm wrapping machines may also be used on rotating-load or pallet wrapping machines, in which case at least the counter-rod 4 with the associated

actuating means is mounted on the periphery of the carousel carrying the load.

Claims

1. Apparatus for fixing, without welding, the tail end of the wrapping of palletized loads, formed using stretch film and/or other elastic and/or plastic material, in particular for rotating-arm or rotating-load wrapping machines, **characterized in that** it comprises:
 - a straight counter-rod (4) which during the final stage of the wrapping cycle is raised, arranged vertically and brought up alongside the bottom part of the load, at the correct distance from the latter, so as to ensure that at least the last turn of the wrapping rests on this rod so as to create in the side and bottom part of the said wrapping a pocket (S) of suitable amplitude which is open both upwards and downwards and inside which a portion of the said last turn is sufficiently spaced from the load;
 - means for stopping the wrapping machine when the tail end of the wrapping, which is wholly or partly overlapped by the turn forming the pocket, is at a small distance or touches the said pocket (S) with the associated internal forming rod (4);
 - means (21, 24) for transversely compressing into a bundle at least one section of the tail end of the wrapping, and a secondary gripper (321) and a primary gripper (22) for retaining successive portions of the said bundle of film, these grippers being situated at a small distance from each other and the secondary gripper being closer to the wrapped load;
 - means (23) for cutting the section of film along the section comprised between the said two grippers (321, 22) so as to define the tail end of the wrapping (X) which is retained by the secondary gripper (321) and the front end (Y) of the future wrapping which is retained by the main gripper (22);
 - means for inserting the secondary gripper (321) with the tail end of the wrapping into the said pocket (S), with insertion from the top part of the said pocket, and means being envisaged for opening this gripper and for extracting it from the pocket and bringing it back into the rest position;
 - means which in synchronism with the means according to the previous point extract from the bottom part of the pocket the rod (4) which formed it, bringing this rod into the rest position such that, owing to the elastic memory effect of the wrapping film, the pocket is closed and elim-

inated, becoming a compressed part of the wrapping and retaining inside it the tail end of the said wrapping.

2. Apparatus according to Claim 1, in which a base frame (1) is provided laterally with respect to the wrapping station of the wrapping machine and laterally with respect to the travel path of the loads to be wrapped, the said base frame in rotating-arm wrapping machines supporting all the components of the said apparatus in question and in rotating-load wrapping machines supporting all the components of this apparatus, with the exception of the counter-rod (4) for forming the pocket (S) in the wrapping, which is mounted on the periphery of the carousel which rotates the load, the location of the said frame being such that the components of the apparatus, in their rest position, do not interfere with the load to be wrapped and with the bottom turns of the wrapping of the said load.
3. Apparatus according to Claim 1, in which the counter-rod (4) which determines the formation of the pocket (S) in the bottom part of the wrapping usually has a round cross section, has a length which is proportional to the height of the last turn of the wrapping film and with its bottom end is hinged on a horizontal shaft (3) rotatably supported by a support (2) mounted on the base frame (1) with the possibility of adjusting the orientation about a vertical axis (102), so as to ensure that, during installation of the apparatus, the said rod (4), when it is in the horizontal rest position, is directed towards the load and forms with the latter an acute angle having an amplitude such as to limit the interference of the said rod with the pocket (S) when the said rod is brought from the active position into the rest position, the said pivoting shaft (3) of the rod (4) being connected via a lever (6) to a pivoting actuator (5) which brings the said rod from the horizontal, lowered, rest position into the vertical, raised, working position and vice versa.
4. Apparatus according to Claim 3, in which the free end of the rod (4) for forming the pocket (S) in the wrapping has mounted thereon a roller (104) freely rotatable about an axis substantially coinciding with the longitudinal axis of the said rod, this roller being provided in order to facilitate disengagement of the rod from the pocket during the last stages of the working cycle of the apparatus.
5. Apparatus according to Claim 4, in which the roller (104) of the counter-rod (4) has rounded edges.
6. Apparatus according to Claim 5, in which the roller (104) of the counter-rod (4) has the top end rounded in the form of an ogive and has a cap shape so as

to circumscribe rotationally an upper section of the said rod.

7. Apparatus according to Claim 3, in which special damping and end-of-travel means are envisaged for controlling and limiting the displacement of the counter-rod (4) and/or the associated movement means (5, 6).
8. Apparatus according to Claim 1, **characterized in that** a primary plate (7) is provided laterally with respect to the counter-rod (4), in a position such as to be located on the outside of the pocket (S) formed in the wrapping of the said rod, said plate with its end being pivotably mounted on a horizontal shaft (8) perpendicular to the load during wrapping and rotatably supported by support brackets (9) fixed to the base (1) of the apparatus and having fixed at one end a right-angled lever (10) hinged with the stem of an alternating movement actuator (11) mounted on the said base, all of which so that, by means of this actuator (11), the said primary plate (7) can be brought from the vertical rest position with a downwards orientation, into the horizontal active position, there being mounted on this plate with a secondary plate (14) arranged in between the means (221) for bundling together the tail end of the wrapping and at least the secondary gripper (321) which retains the said tail end of the wrapping so that, depending on the vertical or horizontal positioning of the said plate, these means are respectively in the lowered rest position or in the raised working position.
9. Apparatus according to Claim 8, in which special damping and end-of-travel means are envisaged for stopping correctly the pivoting plate (7) in the vertical rest position or in the horizontal working position.
10. Apparatus according to Claim 8, in which the said primary pivoting plate (7) has mounted thereon, parallel thereto and rotatable about an axis (13) perpendicular to this plate, a secondary plate (14) on which the means (221) for bundling together the tail end of the wrapping and at least the secondary gripper (321) which retains the said tail end of the wrapping are mounted, the said secondary plate being provided for example laterally with an appended part (114) connected to an actuator for performing an alternating rectilinear movement (15), mounted on an arm (107) of the said primary plate (7), all of which so that the operating means mounted on the secondary plate may, upon actuation, be made to rotate for example through ninety degrees or by a suitable amount about their longitudinal axis or about a parallel axis, so as to pass from the rest position where they are located in an ideal vertical

plane parallel to the load into an active position where they are located in a substantially vertical ideal plane perpendicular to the said load.

11. Apparatus according to Claim 10, in which special damping and end-of-travel means are envisaged for correctly stopping the secondary plate (14) in the two different positions angularly spaced from each other at ninety degrees.
12. Apparatus according to Claim 10, in which the rotation of the secondary plate (14) about its perpendicular axis (13) may be performed using means other than the lever arm with the associated pivoting actuator, for example using a rack-and-pinion assembly (113) with associated fluid pressure cylinder (15') for alternately actuating the said rack, these means being located underneath the primary plate (7) so as to form a substantial counterweight for the operating means mounted on the said secondary plate (14), with advantages of the dynamic type, also because these means are **characterized by** a plan volume having a small projection relative to the pivoting fulcrum (8) of the said primary plate (7).
13. Apparatus according to Claim 10, **characterized in that** the secondary plate (14) has, fixed perpendicularly thereon, at least one straight guide (17), for example of the tubular type, with a polygonal cross section and height slightly greater than the height of the turns forming the pocket (S) in the wrapping of the load, inside which a rod-shaped and adjustable slide (19) telescopically slides with the aid of means (18) having a low coefficient of friction, the said slide being able to be extended or retracted by means of a rectilinear actuator (20) fixed also, via its body, onto the secondary plate (14) and acting on an upper part of the said slide which rigidly carries an arm (119) in the form of an overturned "L" which has a section parallel to and alongside the said slide (19) and on the bottom end of which an operating unit (21) for bundling together the tail end of the wrapping film is mounted.
14. Apparatus according to Claim 13, in which the said operating unit (21) comprises a body (121) which is fixed on the bottom end of the arm (119) with the possibility of being mounted in the correct position with rotation about the longitudinal axis of the said arm and of being able to be locked in the most suitable position, the said body being designed to support the ends of a pair of fork members (221) which are made for example from a round metal bar and which project from the bottom part of the said body, which diverge downwards and which are identical and parallel to each other, the said body (121) being designed to carry, hinged at the bottom, between the said pair of fork members (221), the pair of jaws

(321) of a secondary gripper which are actuated with a self-centring movement by an actuator which is housed in the said body (121), it being envisaged that, when the jaws (321) are in the open position, their active and preferably toothed surface is raised with respect to the overturned V part of the said fork members (221), whereas, when they are closed, the said jaws project from this V-shaped part and are arranged in the middle of the latter, so as to grip the bundle of the tail end of the wrapping gathered in this same V-shaped part of the fork members (221).

15. Apparatus according to Claim 14, **characterized in that** it comprises means for ensuring that, when the said apparatus is in the horizontal rest position, the hook-shaped telescopic assembly (17, 19, 119) which carries the unit (21) with the bundling fork members and the secondary gripper lies in an ideal vertical plane and is in the contracted position, there being provided means for ensuring that, once the pocket (S) has been formed in the wrapping, the wrapping machine stops with the arm carrying the reel (Z) in a predetermined and constant angular position, with the tail end of the wrapping which is situated at a short distance from the counter-rod (4) which forms the said pocket (S) and which for this reason is located in a correct position for gripping by the said unit (21), means being envisaged so that in synchronized sequence the said telescopic assembly (17, 19, 119) is raised into a vertical position and is simultaneously extended so that, at the end of the raising stroke, the unit (21) with the fork members and the secondary gripper is located above the tail end of the wrapping, and finally means being envisaged for ensuring that this unit is subsequently lowered so that its pair of fork members (221) moves down onto the tail end of the film and bundles it together along its bottom edge (B) which rests on a counter means (24) which is for example fixed, and at the end of this step it being envisaged closing the jaws (321) of the secondary gripper so that the latter retains the tail end of the wrapping.
16. Apparatus according to Claim 15, **characterized in that** the carriage of the wrapping machine which carries the reel (Z) of wrapping film may be provided with means which at least during the final stages of formation of the bottom pocket (S) in the said wrapping reduce substantially and symmetrically the width of the wrapping film.
17. Apparatus according to Claim 15, **characterized in that** a variable positioning means may be slidably mounted on the guide (17) of the telescopic assembly which carries the unit (21) with the bundling fork members (221) and with the secondary gripper (321), the said means normally being in the bottom part of the said guide and, when the latter is raised,

being arranged underneath the tail end of the film and by associated means being raised while the unit (21) is lowered so that bundling of the tail end of the wrapping inside the fork members (221) is performed with a smaller or minimum downward stroke of the said unit (21).

18. Apparatus according to Claim 15, **characterized in that** the said counter-means (24) against which the bottom edge (B) of the tail end of the wrapping rests during bundling together in the fork members (221) associated with the secondary gripper (321) may be mounted on raising and lowering means so as to be able to be raised in synchronism with lowering of the said secondary gripper so that bundling together of the tail end of the wrapping in the said fork members (221) is performed with a smaller or minimum downward stroke of the said unit (21).
19. Apparatus according to Claim 14, **characterized in that** means are envisaged for ensuring that, following closing of the jaws (321) of the secondary gripper, closing, at a short distance from the latter, onto the section of the tail end of film situated between the said secondary gripper and the supply reel (Z), of a primary gripper (22) is activated, the said primary gripper being also mounted for example on the fixed frame (1) and provided with means which normally keep it in an open position where it does not interfere with the wrapping film and which, upon actuation, bring it into a position for closing its jaws, in order to grip the said section of film which will form the front end of the future wrapping performed by the wrapping machine and which, after intervention of the gripper in question, will be separated from the tail end of the wrapping being performed, by the activation of cutting means (23).
20. Apparatus according to Claim 19, **characterized in that** the primary gripper (22) may be provided with means which, before closing, raise it so as to contribute to bundling together of the tail end of the wrapping and so as to reduce the stroke of the upper unit (21) which carries the pair of fork members (221) for bundling together the film and the secondary gripper (321).
21. Apparatus according to Claim 19, in which the primary gripper (22) comprises a jaw (122) fixed transversely and with a substantially horizontal arrangement underneath the bottom edge (B) of the tail end of the film and comprises a jaw (222) which in the rest position is aligned longitudinally with respect to the fixed jaw, is remote from the latter and with its end consecutive thereto is fixed onto a horizontal and perpendicular rotational shaft (125) which may be pivoted for example by means of a gear wheel (25, 27) actuated by a rectilinear actuator (29) so

that the said pivoting jaw (222) can be brought from the said rest position into the active position arranged on top of the fixed jaw, in order to retain the future front end of the wrapping film (Y).

22. Apparatus according to Claim 19, in which the cutting means (23) consist for example of a blade with sawteeth which is directed upwards and is integral with a carriage (31) which slides inside a tubular guide (32) parallel and alongside the fixed jaw (122) of the primary gripper (22), a rectilinear actuator (33) being housed and hinged with its body inside the said guide, the said actuator moving the said carriage (31) with the saw (23) which projects from the said guide (32) through a longitudinal window (132) and which in the rest position is protected inside a bridge-piece (35), it being envisaged that, after closing of the primary gripper (22), the blade (23) is moved away from the said protection bridge so as to interfere with the section of film which lies between this gripper and the secondary gripper, in order to separate the tail end (X) of the wrapping retained by the said secondary gripper (321), from the front end (Y) of the future wrapping which is retained by the said primary gripper (22).

23. Apparatus according to Claim 22, in which after separation of the tail end (X) of the wrapping in progress, retained by the secondary gripper, from the front end (Y) of the future wrapping, retained by the primary gripper (22), means are envisaged for raising the telescopic assembly with the secondary gripper (321) and then rotating this assembly through ninety degrees about its vertical axis so as to bring the secondary gripper above the pocket of the film (S), after which means are envisaged for lowering the assembly in question, so as to insert the secondary gripper into the said pocket and then open this gripper, so as to leave the tail end of the wrapping (X) inside the pocket (S), there thus being envisaged means which effect raising of the assembly of the secondary gripper and its return into the rest position with movements opposite to those of the active step, and means being envisaged for effecting lowering into the rest position of the counter-rod (4) which formed the pocket so that the latter elastically closes in order to retain the tail end (X), while in synchronized sequence suitable means perform the removal of the load wrapped by the wrapping station.

24. Apparatus according to Claim 23, in which the arm (119) of the slide (19) which carries the unit (21) with the secondary gripper (321) supports a guide or sliding shoe (36) which extends in bridge fashion from the gripper so as to form a protection which, during insertion of this gripper into the said pocket (S) of the wrapping, is directed outwards so as to

come into contact with the film which forms the said pocket when the secondary gripper is extracted from the said pocket so as to avoid damaging interference between the gripper and the film.

25. Apparatus according to Claim 19, **characterized in that**, at the start of each successive working cycle of the wrapping machine, means are envisaged for ensuring that the primary gripper (22) remains temporarily in the active state and the arm of the wrapping machine with the reel (Z) starts to rotate about the load, remaining temporarily in the low position with the said reel and, before the latter performs a complete revolution, means are envisaged for ensuring that the said primary gripper opens and is arranged in the rest position where it does not interfere with the unwrapping path of the film from the reel, and there being envisaged activating means (37) which with an air jet push upwards and against the load the front end of the wrapping film (Y) retained beforehand by the said gripper, so that this front end is overlapped by the first turns of the wrapping film and remains completely incorporated within the said wrapping which in this way is correctly formed also during the initial stages.

26. Apparatus according to Claim 25, **characterized in that**, in a different embodiment, means may be envisaged for ensuring that, before the start of each working cycle, the primary gripper (22) pivots closed in the direction of the load so as to move the front end of the film towards the load and that the upper jaw of the jaws of the said gripper then rotates through 180 so as to open with respect to the other jaw which remains in its existing position, while in synchronism the said blowing means are activated so as to push the front end of the wrapping against the load so that it is overlapped by the first turns forming the said wrapping.

27. Apparatus according to Claim 25, **characterized in that** means may be envisaged for ensuring that opening of the primary gripper is activated after the first revolution of the reel (Z) about the load to be wrapped so that the front end of the winding is tucked in between the first and second turn of the said wrapping.

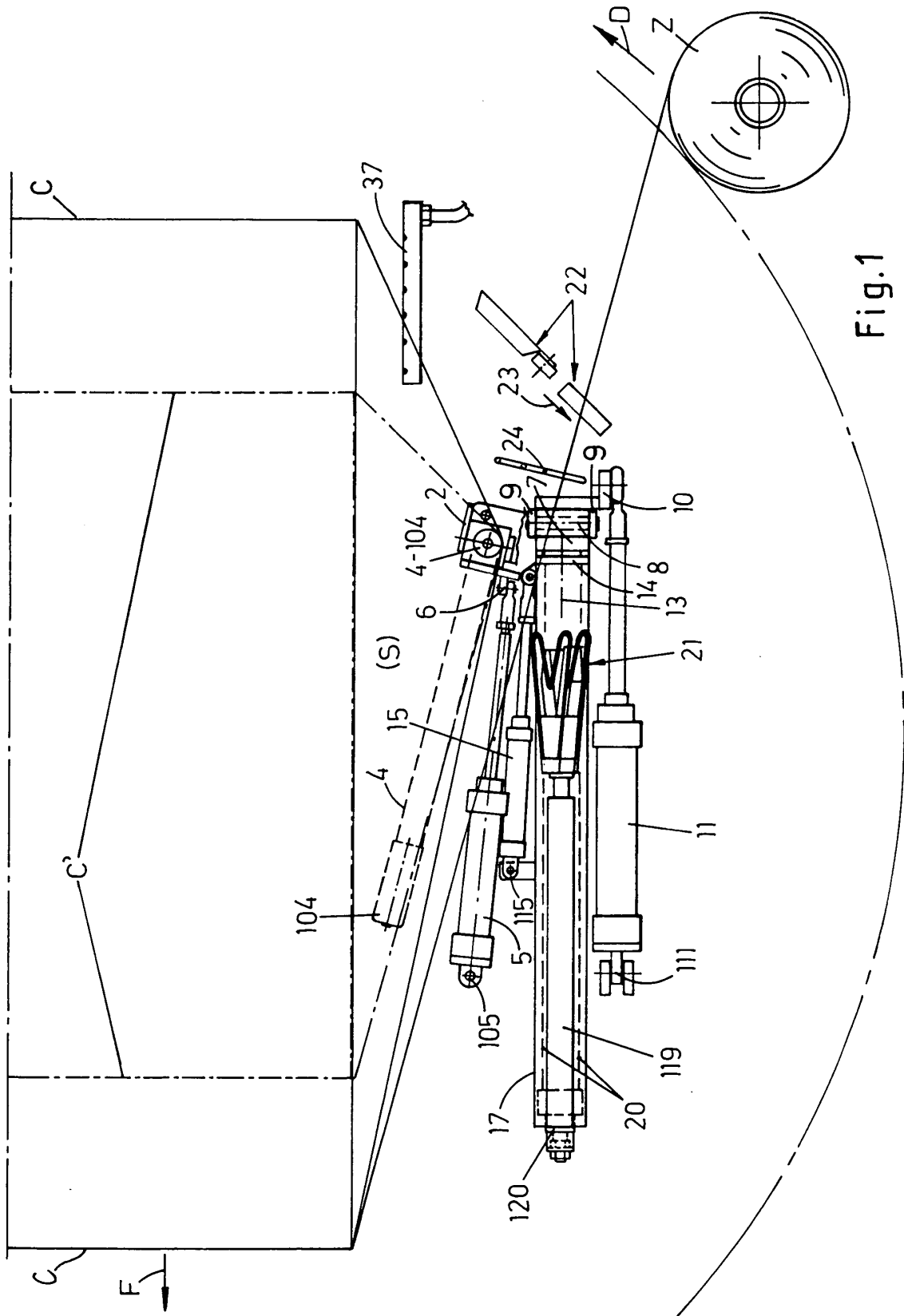

Fig.1

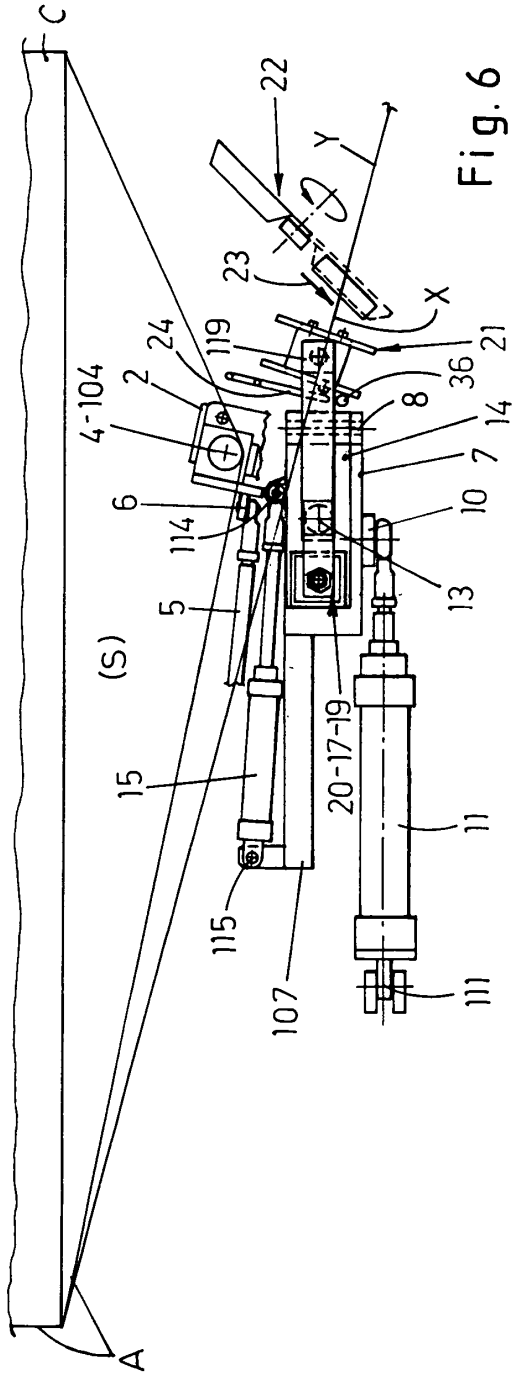

Fig. 6

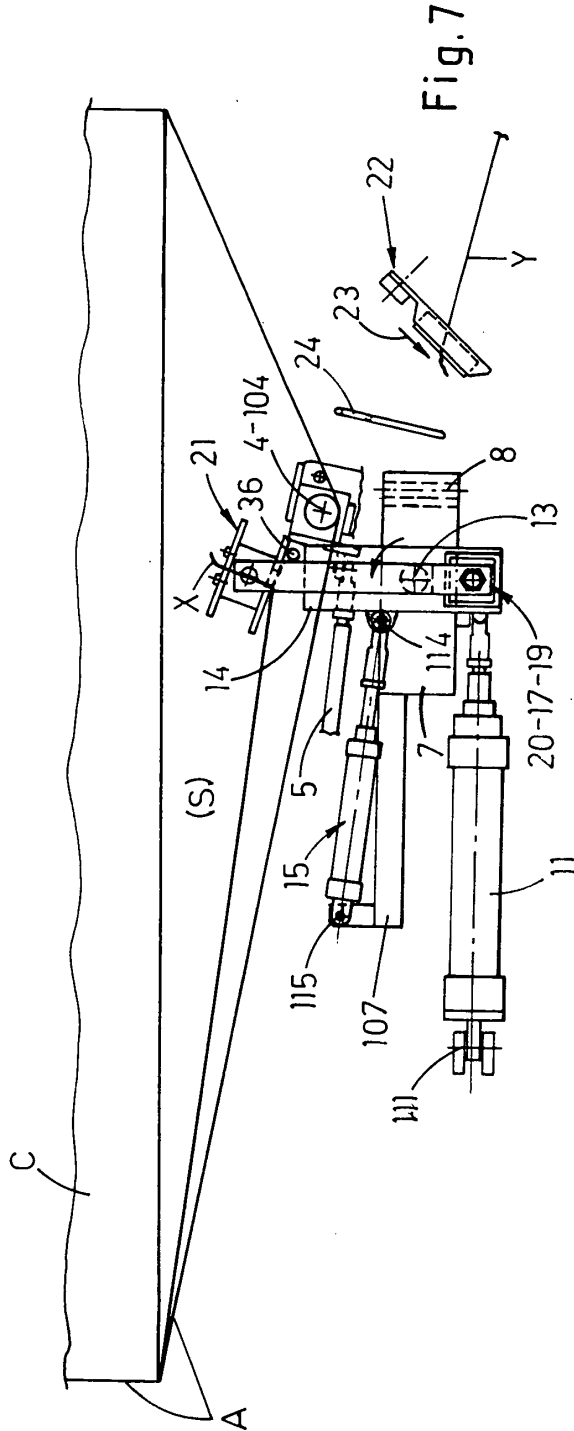
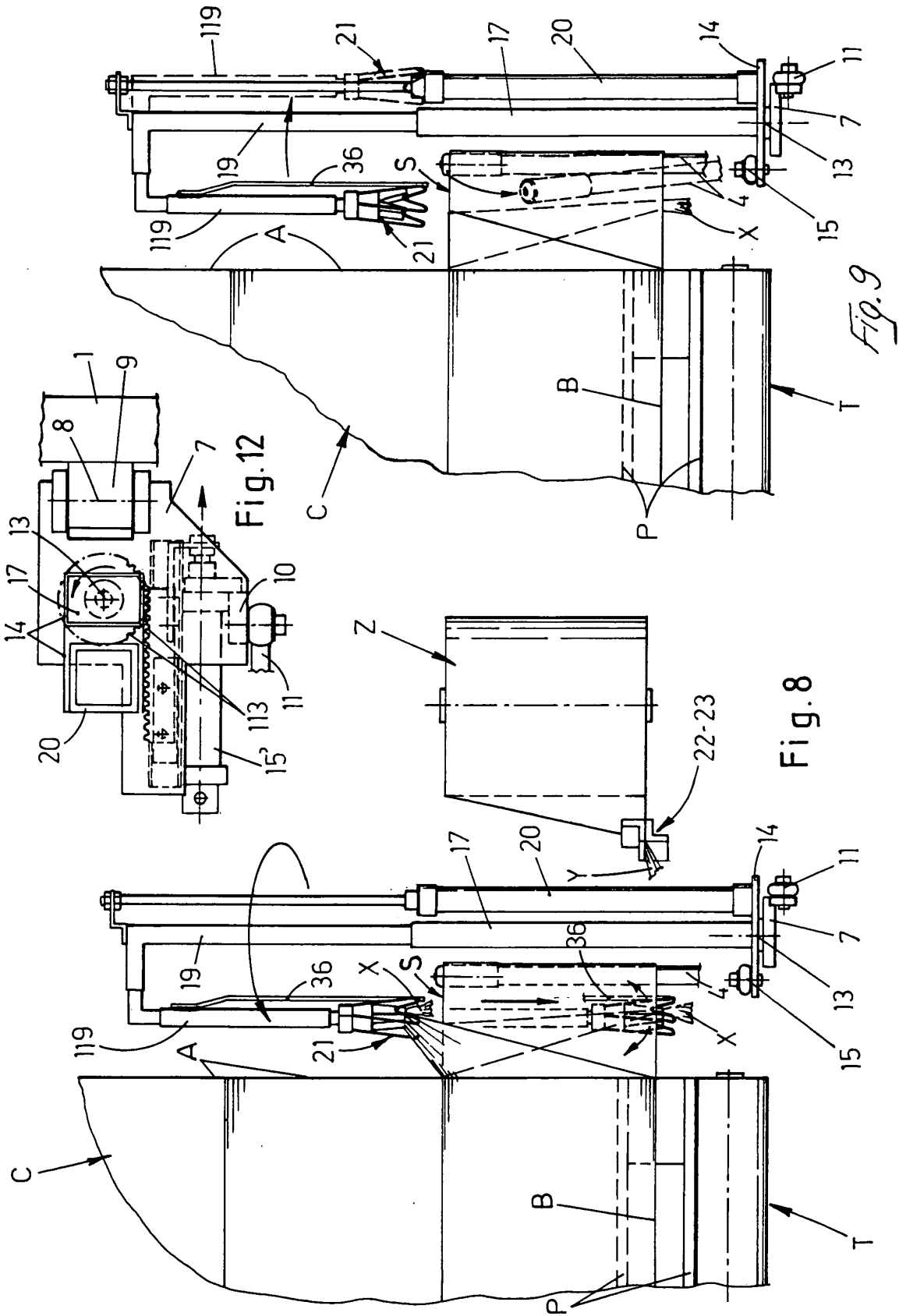
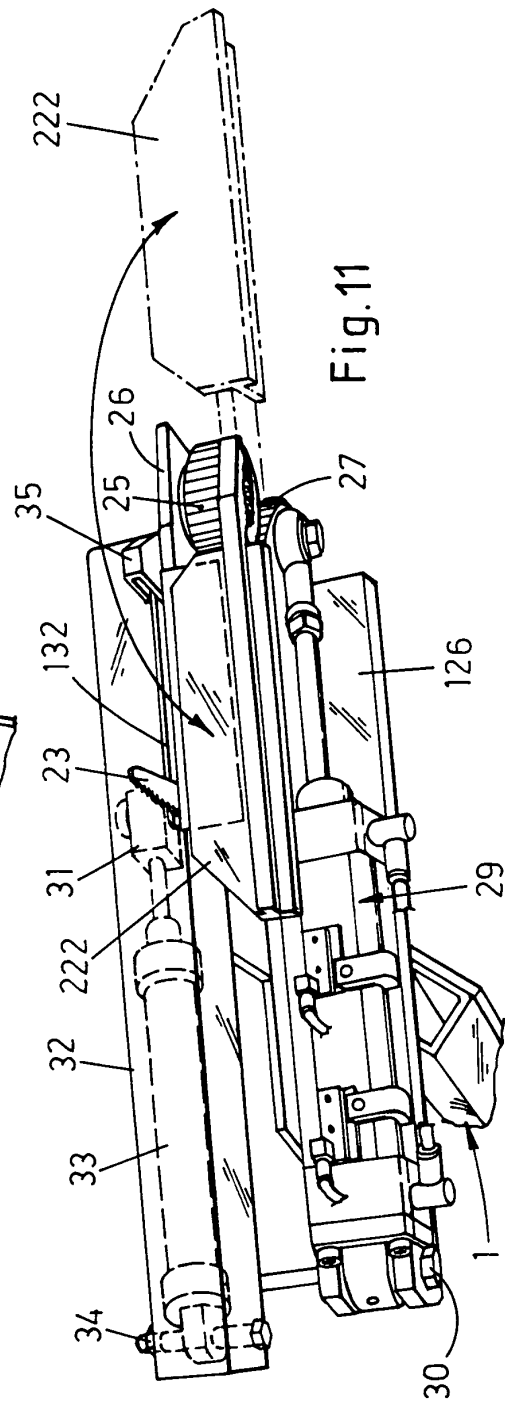
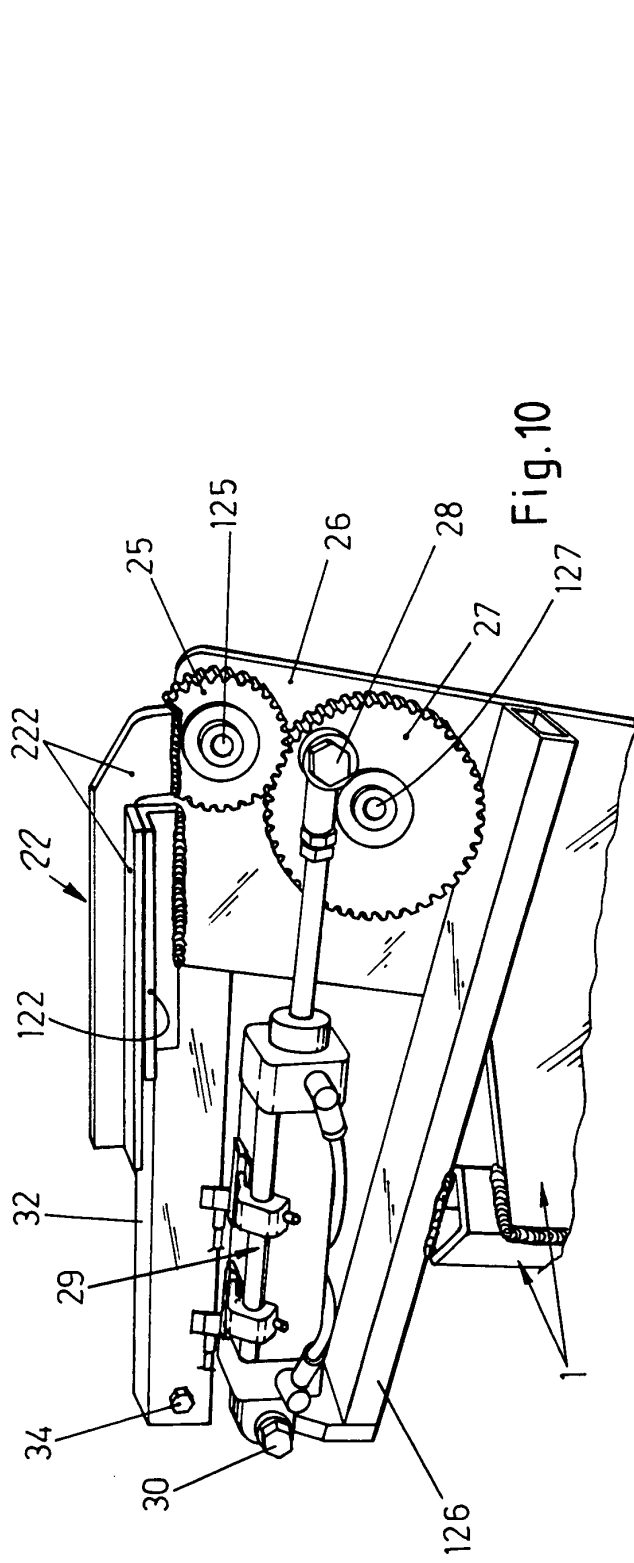

Fig. 7







European Patent
Office

EUROPEAN SEARCH REPORT

Application Number
EP 03 02 7074

DOCUMENTS CONSIDERED TO BE RELEVANT			
Category	Citation of document with indication, where appropriate, of relevant passages	Relevant to claim	CLASSIFICATION OF THE APPLICATION (Int.Cl.7)
D,A	US 6 453 643 B1 (FANTINI DAVIDE ET AL) 24 September 2002 (2002-09-24) * the whole document *	1	B65B11/02
A	US 5 802 810 A (WOJCIK JOHN P ET AL) 8 September 1998 (1998-09-08) * the whole document *	1	
			TECHNICAL FIELDS SEARCHED (Int.Cl.7)
			B65B
The present search report has been drawn up for all claims			
Place of search		Date of completion of the search	Examiner
MUNICH		1 April 2004	Ungureanu, M
<p>CATEGORY OF CITED DOCUMENTS</p> <p>X : particularly relevant if taken alone Y : particularly relevant if combined with another document of the same category A : technological background O : non-written disclosure P : intermediate document</p> <p>T : theory or principle underlying the invention E : earlier patent document, but published on, or after the filing date D : document cited in the application L : document cited for other reasons & : member of the same patent family, corresponding document</p>			

EPO FORM 1503 03.02 (P04C01)

**ANNEX TO THE EUROPEAN SEARCH REPORT
ON EUROPEAN PATENT APPLICATION NO.**

EP 03 02 7074

This annex lists the patent family members relating to the patent documents cited in the above-mentioned European search report. The members are as contained in the European Patent Office EDP file on
The European Patent Office is in no way liable for these particulars which are merely given for the purpose of information.

01-04-2004

Patent document cited in search report	Publication date	Patent family member(s)	Publication date
US 6453643	B1	24-09-2002	IT B0970713 A1 10-06-1999
			AT 236047 T 15-04-2003
			AU 1758799 A 28-06-1999
			CA 2313648 A1 17-06-1999
			DE 69813016 D1 08-05-2003
			DE 69813016 T2 11-03-2004
			DK 1037801 T3 22-04-2003
			EP 1037801 A1 27-09-2000
			WO 9929573 A1 17-06-1999
			ES 2191363 T3 01-09-2003
US 5802810	A	08-09-1998	AU 7324398 A 07-01-1999
			BR 9802288 A 13-10-1999
			CA 2240259 A1 28-12-1998
			EP 0887266 A1 30-12-1998
			JP 11070908 A 16-03-1999

EPO FORM P0459

For more details about this annex : see Official Journal of the European Patent Office, No. 12/82