



(12) **EUROPEAN PATENT APPLICATION**

(43) Date of publication:  
**14.07.2004 Bulletin 2004/29**

(51) Int Cl.7: **B65D 75/58**

(21) Application number: **03388001.4**

(22) Date of filing: **10.01.2003**

(84) Designated Contracting States:  
**AT BE BG CH CY CZ DE DK EE ES FI FR GB GR  
HU IE IT LI LU MC NL PT SE SI SK TR**  
Designated Extension States:  
**AL LT LV MK RO**

• **Daelmans, Eddy**  
**3650 Dilsen-Stokken (BE)**  
• **Loibl, Marc**  
**60810 Brasseuse (FR)**

(71) Applicant: **Amcor Flexibles Europe A/S**  
**8700 Horsens (DK)**

(74) Representative: **Jensen, Peter Kim et al**  
**Chas. Hude A/S**  
**33, H.C. Andersens Boulevard**  
**1780 Copenhagen V (DK)**

(72) Inventors:  
• **Olsen, Erik**  
**8700 Horsens (DK)**

(54) **A box-shaped package of a flexible and sealable packaging material**

(57) A box-shaped package of a flexible and sealable, especially heat-sealable, packaging material including a front wall (1) and a back wall (2) arranged opposite to each other and sealed together along opposed side edges thereof by means of transverse side seams (5,6). The package further includes two opposed and inwardly folded end walls (3,4), a first end wall (3) being sealed to the front and the back walls (1,2) along first longitudinal end seams (9,10) and along first end side seams (11,12) and a second end wall (4) being sealed

to the front and the back walls (1,2) along second longitudinal end seams (15,16) and along second end side seams (17,18). At least one of the side seams is peelable, and at least portions of the front and the back walls (1,2) extend beyond the transverse peelable side seam (5) to form a front wall gripping member (19) and a back wall gripping member (20). Furthermore opening means are provided for opening at least a portion of the front wall (1) in longitudinal direction when the peelable side seam (5) is peeled.

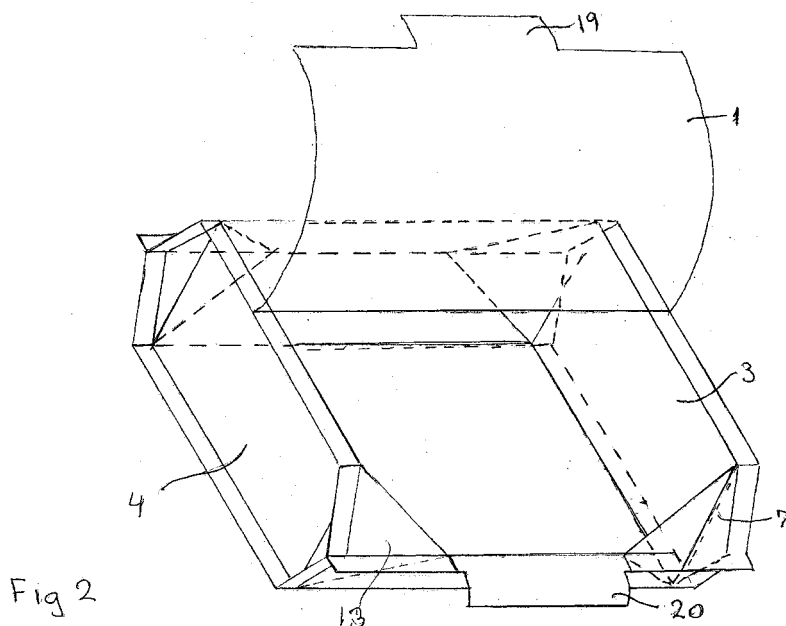

Fig 2

## Description

**[0001]** The invention relates to a box-shaped package of a flexible and sealable, especially heat-sealable, packaging material including:

- a front wall and a back wall arranged opposite each another and sealed together along opposed side edges thereof by means transverse side seams;
- two opposed and inwardly folded end walls, a first end wall being sealed to the front wall and the back wall along first longitudinal end seams and along first end side seams adjacent a respective side seam and a second end wall being sealed to the front and the back walls along second longitudinal end seams and along second end side seams adjacent a respective side seam.

**[0002]** The expression "packaging material" denotes both plastic film-based and paper-based materials and combinations thereof. Further the expression "film" is used in a wide sense to include a monofilm, a co-extruded film, and a laminate including one or more monofilms and or co-extruded films and optionally one or more paper layers.

**[0003]** Packages of this type are *inter alia* known from WO 00/58166 and WO 00/58174. Such packages are preferably made of a web material on vertical form, fill and seal machines. Consequently, the expression "transverse" denotes a direction parallel to the longitudinal direction of the web material, said latter direction also being denoted as the machine direction. Correspondingly the expression "transverse" denotes a direction perpendicular to the machine direction. It should be noted that the packages may be made of a single web of packaging material or of several, eg two or four, packaging material webs. It should also be noted that the packages may be made as pre-fabricated bags, which are subsequently filled and sealed in a fill and seal machine.

**[0004]** The object of the present invention is to provide a package of the above type, which is easily openable and may be provided with an advantageously sized opening allowing for easy access to and removal of the packed product. A special object of the invention is to provide a package for articles of foods, in particular light foods, such as mixed salads, the package being provided with a good sized opening allowing for use of the package as a bowl at consumption of the article of food contained therein.

**[0005]** The package according to the invention is characterised in at least one of the side seams is peelable, that at least portions of the front and the back walls extend beyond the transverse peelable side seam to form a front wall gripping member and a back wall gripping member, and that opening means are provided for opening at least a portion of the front wall in longitudinal

direction when the peelable sealing seam is peeled.

**[0006]** The peelable side seam is peeled by gripping the gripping members or flaps of the front wall and the back wall and pulling these apart. At the same time due to opening means at least a portion of the front wall is opened to provide access to the interior of the package. The contents of the package may be removed through this opening, eg while the package rests on the back wall. It is thus possible to use the package as a bowl at consumption of the article of food contained therein.

**[0007]** Further it should be noted that the present package differs from the above prior art packages in that the peelable side seam is a transverse seam when seen relative to the machine direction (MD in Figure 1), whereas the peelable seams of the above prior art packages are longitudinal seams. This difference is considered advantageous in relation to the manufacture of the package and in relation to the properties of the package.

**[0008]** According to a first embodiment of the invention a first and a second end side seam adjacent the peelable side seam are peelable at least between the front wall and the first and second end walls to optimise the provided opening. As a result the front wall is peelable along its entire transverse extent in the portion at the front wall gripping member.

**[0009]** In the above embodiment of the invention the opening means advantageously includes peelable end seams between the front wall and the first and second end walls to allow for a complete removal of the front wall from the package, at least up to the side seam opposite the peelable side seam and the peelable end side seams. An opening is thus provided completely exposing the contents of the package to allow easy removal thereof.

**[0010]** Furthermore according to the invention, the opening means may include two mutually interspaced incisions or weakening lines in the side edge of the front wall at the peelable side seam or at the peelable end side seams. When the gripping members are gripped and pulled apart, the front wall is peeled in the peelable side seam(s) and further torn longitudinally in line with the incisions or weakening lines, whereby an opening is provided in the front wall. The incisions or weakening lines may optionally extend into the peelable side seam(s).

**[0011]** The above embodiment is particularly suitable when the packaging material includes a plastic film oriented in the longitudinal direction, ie in the machine direction, said oriented film providing a controlled tearing of the packaging material in line with the incisions or weakening lines, when the gripping members are gripped and pulled apart. Examples of such controlled and tearable films are oriented PE (polyethylene), PP (polypropylene), PA (polyamide) and PET (polyester) films.

**[0012]** Moreover, according to the invention the incisions or weakening lines may be provided at either of the end seams between the front wall and the first and

the second end walls, respectively, to obtain as large an opening area as possible. It should be noted that the weakening lines may be formed by means of the sealing bars forming the longitudinal end seams between the front wall and the first and second end walls, the inner edges of the sealing bars weakening the packaging material at the inner edges of the longitudinal end seams. Differently stated the sealing bars provide a notch effect such that the packaging material is torn along the inner edges of the end seams, when the package is opened.

**[0013]** According to another embodiment of the invention, the opening means include two mutually interspaced weakening lines in the front wall extending from a side edge thereof and beyond the peelable side seam or the peelable end side seams. When opening the package, the front wall is peeled in the peelable side seam(s) and further torn along the weakening lines. The weakening lines may advantageously be provided by means of so-called laser cuts, ie by means of a laser beam. The laser used may be a so-called contour laser, ie a laser capable of forming contoured, ie not straight, cuts. However, as well-known in the art the weakening lines may be formed by means of mechanical devices. The weakening lines may further be continuous or discontinuous.

**[0014]** For an optimum control of the tearing action, in the longitudinal direction the weakening lines may extend over the majority of the front wall and preferably at least over two-thirds of the distance to the side seam opposite the peelable side seam.

**[0015]** Furthermore, the weakening lines may be provided at either of the end seams between the front wall and the first and the second end walls and extend substantially parallel to the respective end seam to obtain as large an opening as possible.

**[0016]** Moreover, according to the invention the weakening lines may be arranged symmetrically about a longitudinal centre line of the front wall and extend mutually diverging from the front wall gripping member towards the end seams and then parallel thereto.

**[0017]** The weakening lines may further extend so as to allow a joining thereof, eg they may initially extend parallel to each other and then mutually divergent. As a result the portion of the front wall defined by the weakening lines may be removed completely at opening of the package.

**[0018]** Finally, according to the invention in transverse direction the gripping members may have an extent less than that of the package and be arranged centrally. However, it is to be understood that the front wall and the back wall over their entire transverse width may extend beyond the peelable side seams, whereby the gripping members or flaps may have a transverse width corresponding to the transverse width of the package. Optionally the front wall member may be defined by two mutually interspaced incisions or weakening lines in the projecting portion of the front wall.

**[0019]** The expression "peelable" denotes a seal or a

seam, which may be peeled and which preferably has a strength between 100 and 800 g/20mm, most preferably between 200 and 500 g/20 mm.

**[0020]** Peelable sealing seams may for instance be provided by using a sealing medium sealing peelably to itself. The sealing medium may either be a film, eg a so-called peel PE or peel PP (cast PP), or a coating which may be applied either to the entire inner surface or only to the sealing areas. Another option is to apply a coating, eg a so-called peel lacquer, to a sealing medium fusion-sealing to itself, said coating weakening the sealing strength so as to provide a peel seal. Such weakening coatings may be applied by printing either to the entire inner surface or only to the sealing areas. A third option for providing a peelable seal is to use a laminate or a co-extruded film including a thin inner sealing medium layer, and a superjacent layer, the peel strength between the said layers being lower than the sealing strength obtained when the sealing medium is heat-sealed to itself. A peeling of the seal causes a tearing of the thin inner sealing layer along the edges of the sealing seam and a delamination between the two layers of the laminate or co-extrudate in the area of the sealing seam. The above peelable seal is also known as a so-called riss peel.

**[0021]** In a modification of the above riss peel, a pressure-sensitive layer, eg a hot-melt, is provided between the above thin inner sealing medium layer and a subjacent layer, the peel strength between the inner layer and the pressure-sensitive layer being lower than the sealing strength obtained when the inner sealing medium layer is sealed to itself. Optionally the inner cohesion of the pressure-sensitive layer is less than the peel strength between the pressure-sensitive layer and the inner sealing medium layer and the sealing strength obtained when the sealing medium layer is sealed to itself. A peeling of the seal causes a tearing of the thin inner sealing medium layer along the edges of the sealing seam and a delamination between the inner sealing medium layer and the pressure-sensitive layer or optionally an inner delamination or splitting of the pressure-sensitive layer. Thus, the pressure-sensitive layer is exposed, when the seal is peeled and may be used for reclosure of the package after the initial opening thereof.

**[0022]** The invention is explained in details below with reference to the accompanying drawings, in which

Figure 1 is an isometric view of a first embodiment of a box-shaped package according to the invention, shown in its closed state,

Figure 2 illustrates the package shown in Figure 1 in its open state,

Figure 3 is a view corresponding to Figure 1 of a modification of the first embodiment shown in Figures 1 and 2,

Figure 4 is an isometric view of a second embodiment of a box-shaped package according to the invention in its closed state, and

Figure 5 illustrates the package shown in Figure 4 in its open state.

**[0023]** The embodiment of a box-shaped package according to the invention shown in Figs. 1 and 2 includes a front wall 1 and a back wall 2 arranged opposite each other and opposing first and second end walls 3,4. The front wall 1 and the back wall 2 are sealed together inner face to inner face along transverse side seams 5, 6 extending along opposing side edges.

**[0024]** The first end wall 3 is folded inwards at the end portions 7, 8 thereof and sealed to the front wall 1 and the back wall 2 along transverse first end seams 9, 10. In its inwardly folded end portions 7, 8 the first end wall 3 is sealed to itself outer face to outer face and to the front wall 1 and the back wall 2 inner face to inner face along first opposing end side seams 11, 12. Thus the inwardly folded end portions 7, 8 of the first end wall 3 are sandwiched between the front and back walls 1, 2 at the first end side seams 11, 12. The first end side seams 11, 12 are aligned with the transverse side seams 5, 6 between the front wall 1 and the back wall 2.

**[0025]** The second end wall 4 is also folded inwards at the end portions 13, 14 thereof and sealed to the front wall 1 and the back wall 2 along second transverse end side seams 15, 16. In the inwardly folded end portions 13, 14 the second end wall 4 is sealed to itself outer face to outer face and to the front wall 1 and the back wall 2 inner face to inner face along second opposing end side seams 17, 18. As a result, the inwardly folded end portions 13, 14 of the second end wall 3 are sandwiched between the front wall 1 and the back wall 2 at the second end side seams 17, 18. The end side seams 17, 18 are aligned with the transverse side seams 5, 6 between the front wall 1 and the back wall 2.

**[0026]** In the side seams portion the front wall 1 and the back wall 2 are extended in the longitudinal direction such that they extend beyond the side seam 5 to form a front wall gripping member 19 and a back wall gripping member 20. The side seam 5 is a peelable seam. The adjacent end side seams 11 and 17 between the front wall 1 and the first and second end walls 3, 4 are also peelable seams. Finally the longitudinal end seams 9, 15 between the front wall 1 and the end walls 3, 4 are peelable. When the front wall gripping member 19 and the back wall gripping member 20 are gripped and pulled away from one another, the peelable side seam 5, the peelable end side seams 11, 17 between the front wall 1 and the end walls 3, 4, and the peelable end seams 9, 15 between the front wall and the end walls 3, 4 are peeled. As seen in Figure 2, an opening to the interior of the package is thus provided to allow easy removal of the contents of the package through the formed opening. When the front wall 1 is peeled, the end

side seams 11, 17 remain intact, ie. are left non-peeled, in the sealing areas between the back wall 2 and the inwardly folded end portions 7, 13 of the end walls 3, 4 and in the sealing areas between the outer faces of the inwardly folded portions 7, 13, confer Figure 2.

**[0027]** In a modification of the above embodiment instead of being arranged centrally, the gripping members 19A, 20A extend over the entire transverse width of the packaging, as shown in Figure 3.

**[0028]** An example of a suitable packaging material for the above embodiment is the laminate coex. OPP/peel PE, wherein peel PE is a polyethylene-based sealing medium layer sealing peelably to itself and coex. OPP denotes a co-extruded oriented polypropylene film provided with a thin sealing medium layer on each side including a copolymer of PP and PE. The peel PE film is the inner layer when seen in relation to the finished packaging. The thickness of the coex. OPP film may for instance be 60  $\mu\text{m}$  and the thickness of the peel PE film may for instance be 20  $\mu\text{m}$ . In order to obtain improved barrier properties, one or more barrier layers, eg of polyvinylidene chloride (PVdC) or of ethylenevinyl alcohol (EVOH) or a metallization layer, may be provided between the peel PE film and the coex. OPP film.

**[0029]** The package may advantageously be manufactured and filled on a vertical form, fill and seal machine, preferably from a single web of packaging material. By this manufacturing method the web material is fed into the machine's filling tube having a rectangular cross section and is formed into a hose of a rectangular cross section, three of the end seams being formed by folding and sealing the web material, while the fourth end seam is formed by sealing the edges of the web material.

**[0030]** The fourth end seam may for instance be the end seam 9 between the front wall 1 and the first end wall 3. Since the web material is continuous at the three folded and sealed end edges, the fold at the end seam 15 opposite the end seam 9 has to be cut away in the longitudinal direction to allow for peeling of the end seam 15 between the front wall 1 and the second end wall 4, when the finished package is to be opened. The removal of the said fold may advantageously be performed on the filling tube immediately after completion of the end seam 15.

**[0031]** The transverse side seams 5, 11, 17 are provided in a manner known *per se* below the filling tube after the formation of the inwardly folded portions 7, 13. The hose is then advanced by a distance corresponding to the longitudinal extent of the finished package and filled with the product to be packed. Finally, the inwardly folded end portions 8, 14 of the end walls 3, 4 and then the transverse side seams 6, 12, 18 are formed. While the latter sealing seams are being formed, the gripping members 19, 20 are also formed, and the formed, filled and sealed package is separated from the hose.

**[0032]** The second embodiment of the invention shown in Figures 4 and 5 corresponds widely to the first embodiment shown in Figs. 1 and 2 and thus includes

a front wall 1 and a back wall 2 being sealed together by means of transverse side seams 5, 6, and first and second end walls 3, 4, each having inwardly folded end portions 7, 8; 13, 14. The first end wall 3 is sealed to the front and back walls 1, 2 along first longitudinal end seams 9, 10 and along first end side seams 11, 12. In a corresponding manner the second end wall 4 is sealed to the front and back walls 3, 4 along second longitudinal end seams 15, 16 and along second end side seams 17, 18. Finally, the package is also provided with gripping members 19, 20 formed by a longitudinal extension of the front and back walls past the side seam 5. In respect of the above the second embodiment shown in Figures 4 and 5 is identical to the first embodiment shown in Figures 1 and 2.

**[0033]** However, the second embodiment differs from the first embodiment by the front wall 1 being provided with two mutually interspaced, longitudinal weakening lines 21, 22 weakening the packaging material to such an extent that it is torn along the weakening lines, when subjected to a predetermined tear force. The weakening lines 21, 22 are provided adjacent a respective end seam 9, 15 between the front wall 1 and the first and second end walls 3, 4. The weakening lines extend from the free end edge 23 of the front wall 1 over the majority of the front wall 1 in the longitudinal direction.

**[0034]** For opening the package the gripping members 19, 20 are gripped and pulled away from each other, whereby the peelable side seam 5 is peeled. Furthermore the adjacent peelable end side seams 11, 17 between the front wall 1 and the first and second end walls 3, 4 are peeled up to the weakening lines 21, 22. Since the strength of the latter peelable sealing seams exceeds that of the tear strength of the weakening lines 21, 22, the front wall is torn along the weakening lines. When the package is opened, the end seams 9, 15 between the front wall 1 and the end walls 3, 4 thus remain intact and narrow longitudinal portions of the front wall remain connected to the end walls.

**[0035]** The same packaging materials may be used for the above embodiment as used for the first embodiment. Since the end seams 9, 10 are not peeled when the package is opened, a packaging material having an inner sealing medium layer, which fusion-seals, ie. it does not seal peelably to itself, may, however, also be used provided that a peelable side seam 5 is provided between the front and back walls 1, 2, and peelable end side seams 11, 17 are provided between the front wall 1 and the end walls 3, 4. These peelable seams may for instance be provided by applying a transverse peel lacquer strip to the sealing medium layer in the portion corresponding to the peelable side seams 5, 11 and 17. Furthermore, since the end seams 9, 15 between the front wall 1 and the end walls 3, 4 are not peeled when the package is opened, the fold at the end seam 15 need not be cut away during the manufacture of the package from a single web of packaging material on a vertical form, fill and seal machine.

**[0036]** It should further be noted that instead of being rectilinear the weakening lines may extend mutually diverging from the front wall gripping member 19 towards the end seams 9, 15 and then extend mutually parallel thereto, as shown by means of dot-and-dash lines 25, 26 in Figure 4. Additionally, it should be noted that the weakening lines 25, 26 may be joined together by means of a transverse weakening line 27, as shown in Figure 4. As a result, the portion of the front wall 1 defined by the weakening lines 25, 26, 27 is removed completely when the package is opened.

**[0037]** Finally, if an easily controlled tearable packaging material is used for the package, such as most oriented films, weakening lines may be omitted in the embodiment shown in Figures 4 and 5. The front wall may instead be provided with two mutually interspaced incisions or weakening lines in the free side edge 23 at the peelable side seams 5, 11, 17. The incisions or weakening lines may optionally extend into the said side seams and may be provided in the same area of the free side edge as the weakening lines 21, 22 shown in Figure 4. When opening the package, the peelable side seams 5, 11, 17 are peeled to the incisions or weakening lines, and the front wall is torn in longitudinal direction substantially in alignment with the incisions or weakening lines.

**[0038]** While the invention has been described in details above with reference to heat-sealable plastic films, it should be understood that the present invention is not restricted to the use of such films. Thus, the present invention also includes the use of paper-based heat-sealable materials and the use of plastic film-based and paper-based cold-sealable materials.

## Claims

1. A box-shaped package of a flexible and sealable, especially heat-sealable, packaging material including:
  - a front wall (1) and a back wall (2) arranged opposite each another and sealed together along opposed side edges thereof by means transverse side seams (5, 6);
  - two opposed and inwardly folded end walls (3, 4), a first end wall (3) being sealed to the front wall (1) and the back wall (2) along first longitudinal end seams (9) and along first end side seams (11, 12) adjacent a respective side seam (5, 6) and a second end wall (4) being sealed to the front and the back walls (1, 2) along second longitudinal end seams (15, 16) and along second end side seams (17, 18) adjacent a respective side seam (5, 6),

**characterised in that** at least one of the side seams (5) is peelable, that at least portions of the

- front and the back walls (1, 2) extend beyond the transverse peelable side seam (5) to form a front wall gripping member (19) and a back wall gripping member (20), and that opening means are provided for opening at least a portion of the front wall (1) in longitudinal direction when the peelable sealing seam (5) is peeled. 5
2. A package according to claim 1, **characterised in that** a first and a second end side seam (11, 17) adjacent the peelable side seam (5) are peelable at least between the front wall (1) and the first and second end walls (3, 4). 10
3. A package according to claim 2, **characterised in that** the opening means include peelable end seams (9, 15) between the front wall (1) and the first and second end walls (3, 4). 15
4. A package according to claim 1 or 2, **characterised in that** the opening means include two mutually interspaced incisions or weakening lines in the side edge (23) of the front wall (1) at the peelable side seam (5) or at the peelable end side seams (11, 17). 20  
25
5. A package according to claim 4, **characterised in that** the incisions or weakening lines are provided at either of the end seams (11, 17) between the front wall (1) and the first and the second end walls (3, 4), respectively. 30
6. A package according to claim 1 or 2, **characterised in that** the opening means include two mutually interspaced weakening lines (21, 22) in the front wall (1) extending from a side edge (23) thereof and beyond the peelable side seam (5) or the peelable end side seams (11, 17). 35
7. A package according to claim 6, **characterised in that** in the longitudinal direction the weakening lines (21, 22) extend over the majority of the front wall (1) and preferably at least over two-thirds of the distance to side seam (6) opposite the peelable side seam (5). 40  
45
8. A package according to claim 6 or 7, **characterised in that** the weakening lines (21, 22) are provided at either of the end seams (9, 15) between the front wall (1) and the first and the second end walls (3, 4) and extend substantially parallel to the respective end seam (9, 15). 50
9. A package according to claim 6 or 7, **characterised in that** the weakening lines (25, 26) are arranged symmetrically about a longitudinal centre line of the front wall (1) and extend mutually diverging from the front wall gripping member (19) towards the end seams (9, 15) and then parallel thereto. 55
10. A package according any of the preceding claims, **characterised in that** in the transverse direction the gripping members (19, 20) have an extent less than that of the package and are arranged centrally.



Fig 2

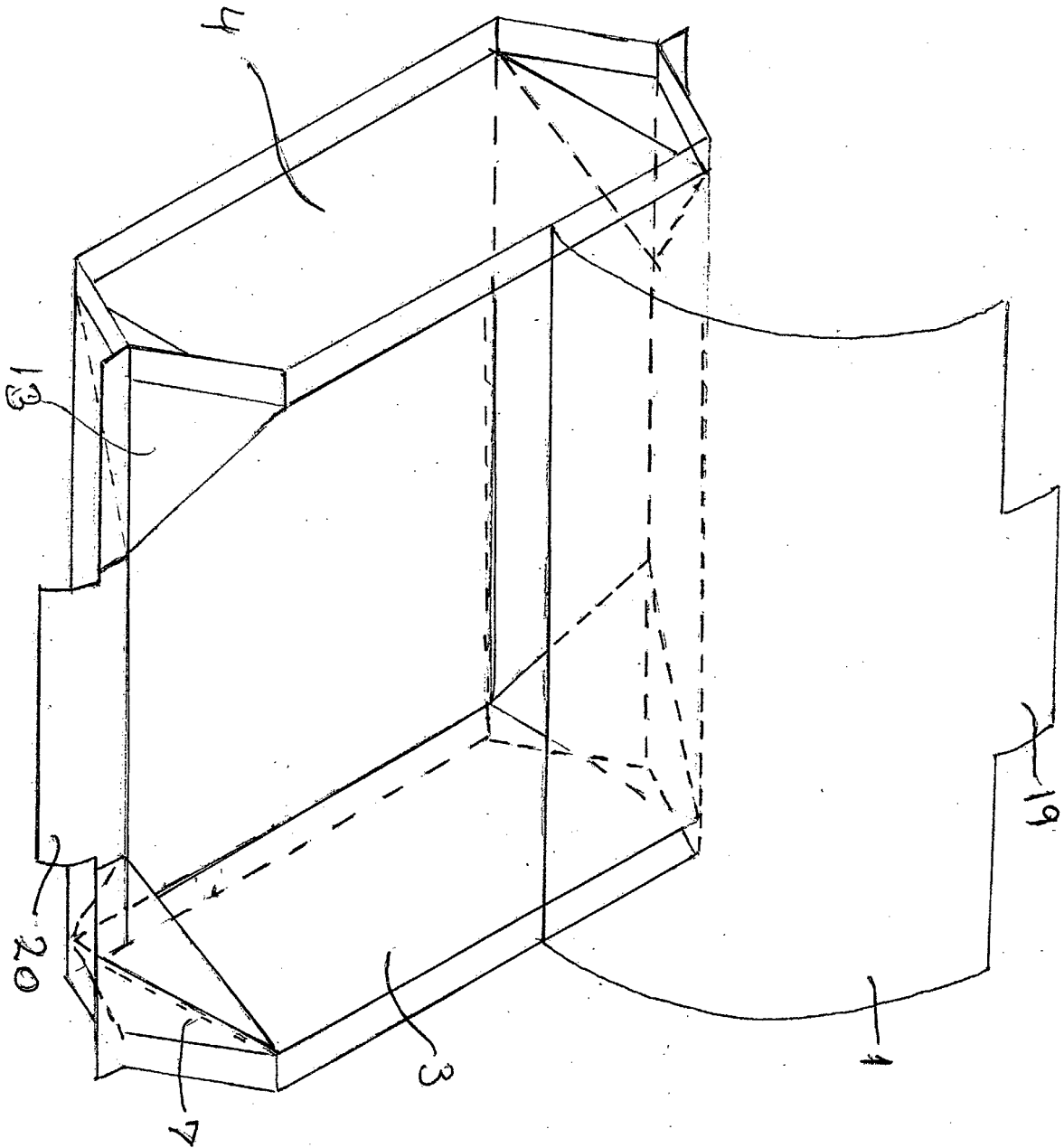
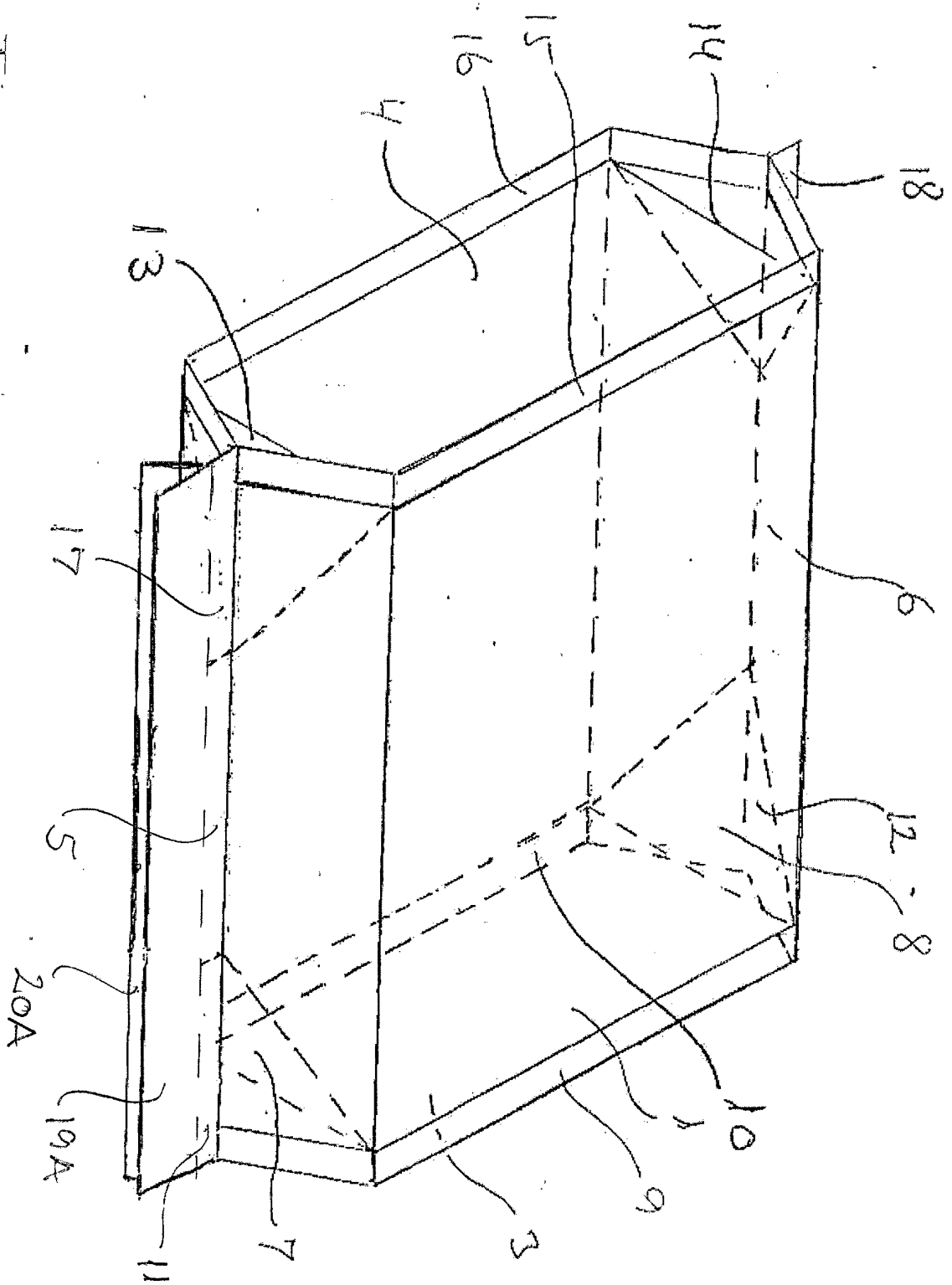

Fig 3



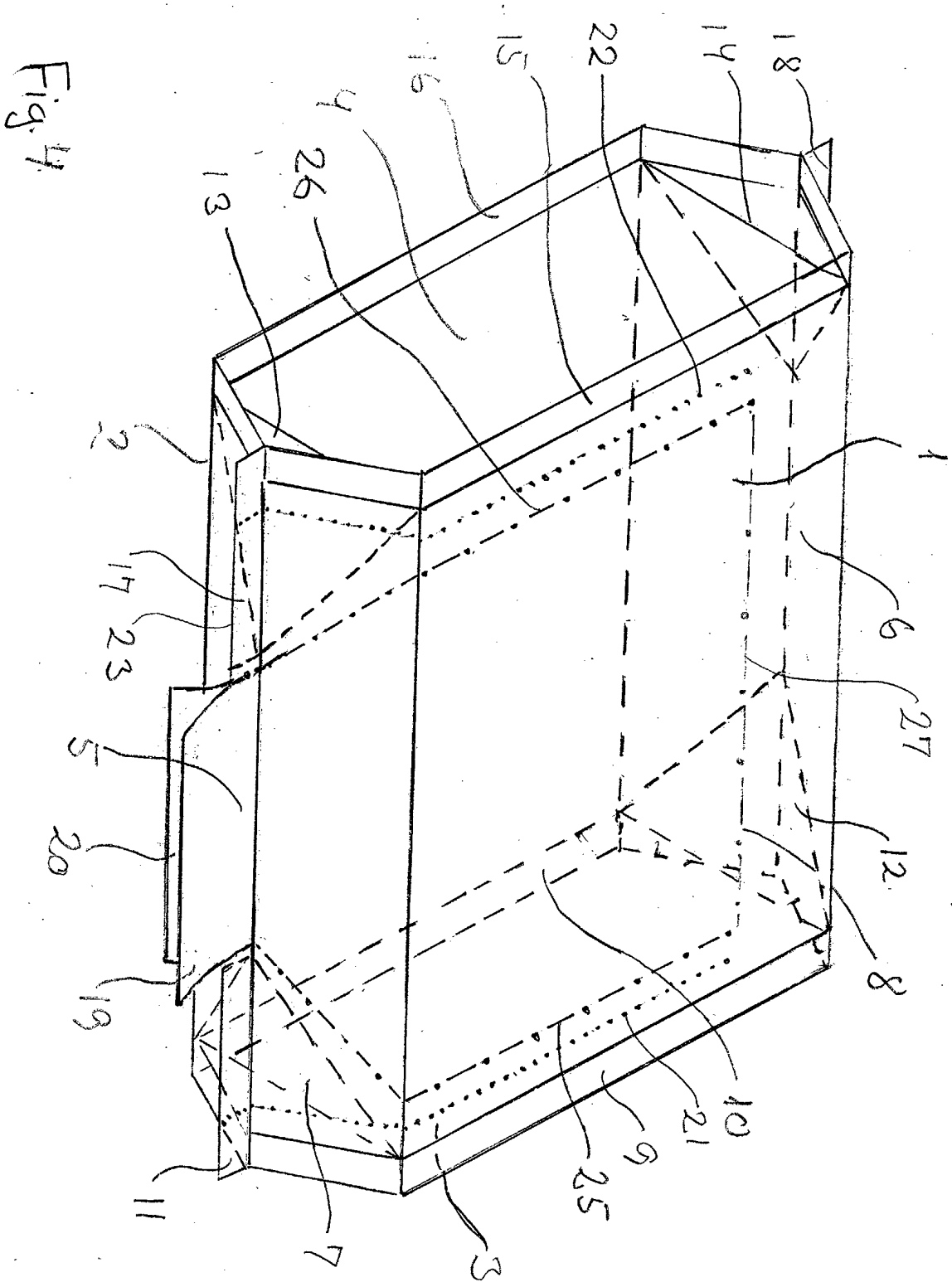
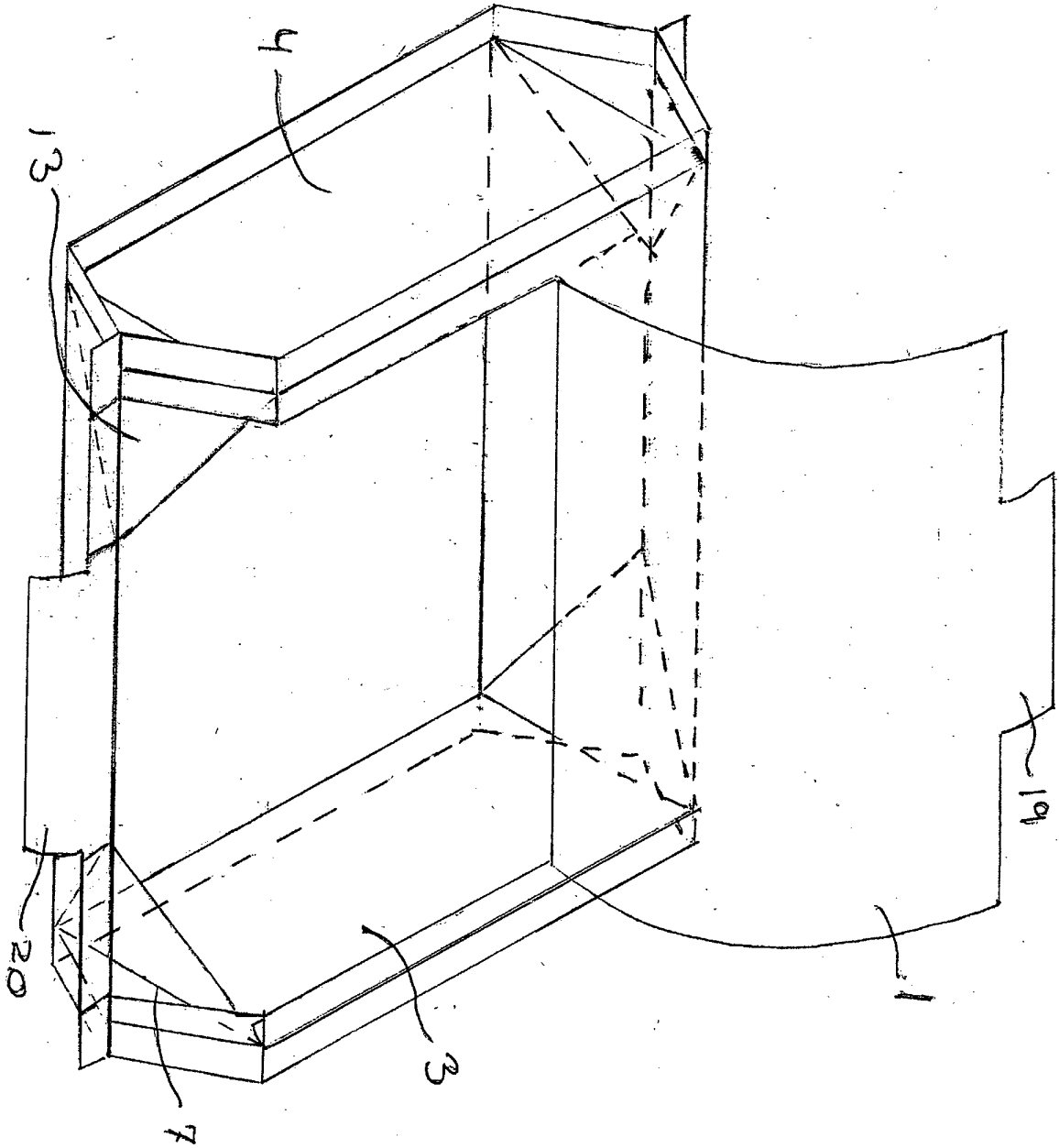

Fig 5





European Patent  
Office

EUROPEAN SEARCH REPORT

Application Number  
EP 03 38 8001

DOCUMENTS CONSIDERED TO BE RELEVANT			
Category	Citation of document with indication, where appropriate, of relevant passages	Relevant to claim	CLASSIFICATION OF THE APPLICATION (Int.Cl.7)
A,D	WO 00 58174 A (DANISCO ;SCHULZ WERNER (DK)) 5 October 2000 (2000-10-05) * page 7, line 5 - line 19; figures 1-3 * ---	1,4	B65D75/58
A	EP 0 972 719 A (KRAFT JACOBS SUCHARD R & D INC) 19 January 2000 (2000-01-19) * column 4, line 49 - column 5, line 15; figure 1 * ---	1,10	
A	US 5 945 145 A (NARSUTIS JO ELLEN NIELSEN ET AL) 31 August 1999 (1999-08-31) * column 7, line 21 - line 50; figures 8-15 * -----	1	
The present search report has been drawn up for all claims			TECHNICAL FIELDS SEARCHED (Int.Cl.7)
			B65D
Place of search	Date of completion of the search	Examiner	
THE HAGUE	16 July 2003	Bridault, A	
CATEGORY OF CITED DOCUMENTS		T : theory or principle underlying the invention E : earlier patent document, but published on, or after the filing date D : document cited in the application L : document cited for other reasons ..... & : member of the same patent family, corresponding document	
X : particularly relevant if taken alone Y : particularly relevant if combined with another document of the same category A : technological background O : non-written disclosure P : intermediate document			

EPO FORM 1503 03 82 (P04C01)

**ANNEX TO THE EUROPEAN SEARCH REPORT  
ON EUROPEAN PATENT APPLICATION NO.**

EP 03 38 8001

This annex lists the patent family members relating to the patent documents cited in the above-mentioned European search report. The members are as contained in the European Patent Office EDP file on  
The European Patent Office is in no way liable for these particulars which are merely given for the purpose of information.

16-07-2003

Patent document cited in search report		Publication date	Patent family member(s)	Publication date
WO 0058174	A	05-10-2000	AT 241527 T	15-06-2003
			AU 3419900 A	16-10-2000
			BR 0009390 A	08-01-2002
			CA 2366417 A1	05-10-2000
			CN 1352613 T	05-06-2002
			CZ 20013408 A3	14-08-2002
			DE 60003028 D1	03-07-2003
			WO 0058174 A1	05-10-2000
			EP 1181216 A1	27-02-2002
			HU 0200557 A2	29-05-2002
			JP 2002540025 T	26-11-2002
			NO 20014620 A	27-11-2001
			NZ 514431 A	30-06-2003
			PL 349998 A1	21-10-2002
			TR 200102758 T2	22-04-2002
-----				
EP 0972719	A	19-01-2000	EP 0972719 A1	19-01-2000
-----				
US 5945145	A	31-08-1999	AU 671735 B2	05-09-1996
			AU 6337394 A	15-12-1994
			AU 7401496 A	30-01-1997
			CA 2117280 A1	11-12-1994
			EP 0629561 A2	21-12-1994
			JP 6345129 A	20-12-1994
			NZ 260711 A	24-02-1997
			NZ 299716 A	26-02-1998
-----				

EPO FORM P0459

For more details about this annex : see Official Journal of the European Patent Office, No. 12/82