



(12) **EUROPEAN PATENT APPLICATION**

(43) Date of publication:
11.08.2004 Bulletin 2004/33

(51) Int Cl.7: **B08B 3/02**

(21) Application number: **03425072.0**

(22) Date of filing: **10.02.2003**

(84) Designated Contracting States:
**AT BE BG CH CY CZ DE DK EE ES FI FR GB GR
HU IE IT LI LU MC NL PT SE SI SK TR**
Designated Extension States:
AL LT LV MK RO

(72) Inventor: **Mariani, Edgardo**
20149 Milano (IT)

(74) Representative: **Mittler, Enrico et al**
**Mittler & C. s.r.l.,
Viale Lombardia, 20
20131 Milano (IT)**

(71) Applicant: **Mariani, Edgardo**
20149 Milano (IT)

(54) **High pressure washing apparatus**

(57) The present invention refers to a high pressure washing apparatus.

In an embodiment the high pressure washing apparatus comprises: an input duct (23) for introducing a fluid at a first pressure in said apparatus; a pump (14) for receiving said fluid and supplying a fluid at a second

pressure; an output duct (22) for supplying said fluid at said second pressure to the outside; characterized by comprising a container (12) placed between said input duct (23) and said pump (14); said container (12) being airtight and having a first volume portion (26) able to contain said fluid and a second volume portion (25) able to contain a compressible fluid.

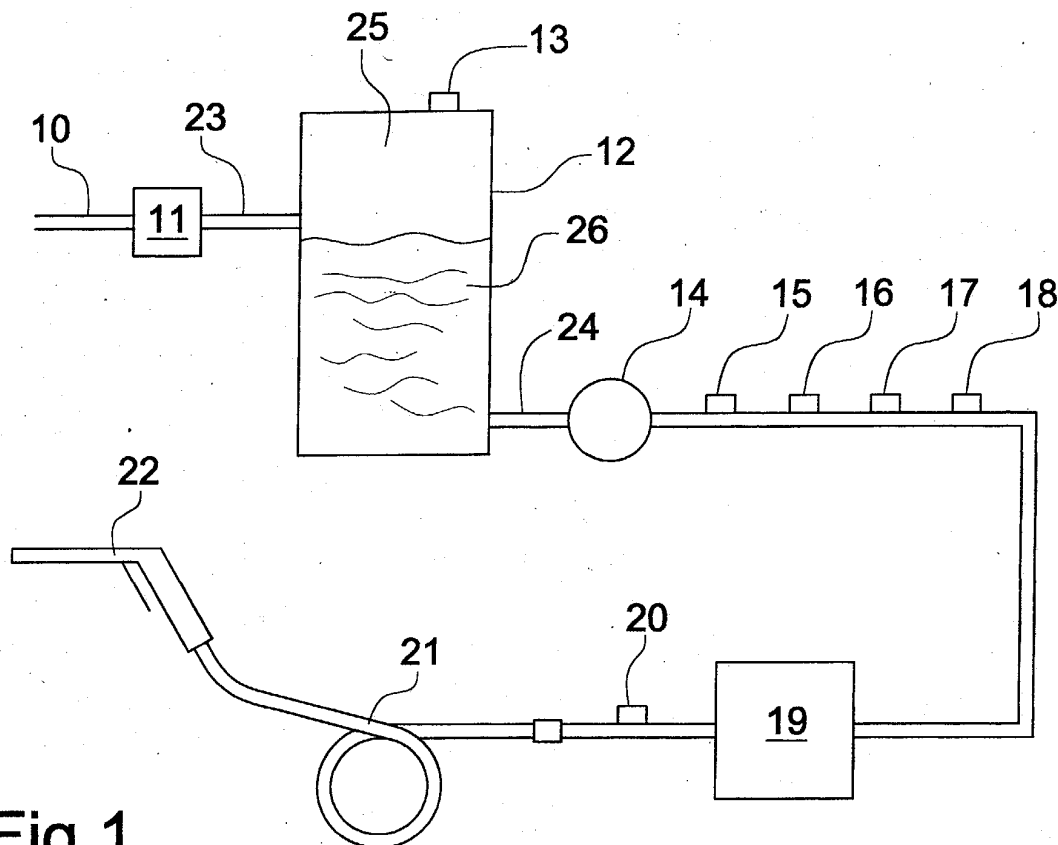

Fig.1

Description

[0001] The present invention refers to a high pressure washing apparatus.

[0002] For high pressure it is meant a pressure higher than the water network pressure up to about 200 bar, typically about 150 bar.

[0003] The high pressure washing apparatuses are normally connected to the water network for the supply of the used water. The hydraulic pressure of the water network varies in absolute value from place to place and can also suffer of temporary variations, faster or less fast, during the use; further, air bubbles can also be present.

[0004] In order to get water at high pressure the washing apparatuses make use of different types of pumps.

[0005] The feeding of such pumps with a varying water flow, as that described above, can cause malfunctions if not the breaking of the same.

[0006] To obviate to these drawbacks accumulation tanks at atmospheric pressure are normally used, placed between the water network and the pumps, provided with float valves to stop the water flow coming from the outside, once reached the prefixed level.

[0007] Such solutions have the drawback that the pump, for its own working, must have the ability to create a depression enough in order to aspire the water at the starting and during its working.

[0008] In view of the state of the art described, it is an object of the present invention to provide an high pressure washing apparatus that does not have the drawbacks of the known art.

[0009] According to the present invention, such an object is achieved by means of a high pressure washing apparatus comprising: an input duct for introducing a fluid at a first pressure in said apparatus; a pump for receiving said fluid and supplying a fluid at a second pressure; an output duct for supplying said fluid at said second pressure to the outside; characterized by comprising a container placed between said input duct and said pump; said container being at airtight and having a first volume portion able to contain said fluid and a second volume portion able to contain a compressible fluid.

[0010] The features and the advantages of the present invention will be made more evident by the following detailed description of a particular embodiment, illustrated as a non-limiting example in the annexed drawings, wherein:

Figure 1 shows a whole block scheme of a high pressure washing apparatus according to the present invention;

Figure 2 shows a representation of an accumulation container in an alternative embodiment according to the present invention.

[0011] A high pressure washing apparatus shown in schematic form in figure 1 includes an input duct 10 to

supply a fluid to the washing apparatus. Such input duct 10 is directly applied to the water network or to any other container or source of fluids suitable for cleaning. Preferably, downstream the duct 10 there is a filter 11 and therefore an accumulation device 12. The accumulation device 12 is equipped with a safety valve 13. Downstream the accumulation device 12 there is a pump 14 for the water pressurization. The pump can be of any type, as those normally used in the hydrocleaning, also with starting difficulty. For example, piston pumps both axial and with oblique disk, centrifugal, at membrane, etc. can be used. The pump 14 is preferably operated by an electric motor (not shown), but it can be operated in any other way. Downstream the pump 14 there is a manostat 15 and a manometer 16, to control the water pressure at the output of the pump 14.

[0012] Downstream the manometer 16 there is an output duct composed, in this case, by a high pressure flexible pipe 21 and by a lance gun 22 for the spillage of the high pressure water.

[0013] In the case in which the washing apparatus is of the type at warm water, downstream the manometer 6 and before the pipe 21, there are preferably a fluxmeter 17, a safety valve 18, a boiler with serpentine 19 and a thermostat 20 for the temperature control. The whole to provide and to regulate the water to a prefixed temperature.

[0014] The accumulation device 12, according to a first embodiment of the present invention, is constituted by an airtight reservoir with a parallelepiped form, placed setting vertically its longer side. It has the water input duct 23 placed at an intermediary height of its height and the water output duct 24 placed at its lower extremity. Preferably, the water input duct 23 is placed at about three quarters of its height, and however it is placed between the 45% and the 90% of the total height.

[0015] An alternative embodiment of the accumulation device 12 according to the present invention is reported in figure 2.

[0016] Instead of being a unique container, as shown in figure 1, it is composed by an lower container 30 and by an upper container 31. The two containers are connected with each other through a duct 32.

[0017] The lower container 30 has a volume included between the 50% and the 90% of the total volume, the upper container 31 has a volume included between the 10% and the 50% of the total volume and the duct 32 has a volume included between the 1% and the 10% of the total volume. In an embodiment the upper container 31 has a volume of about 5 l, the lower container 30 has a volume of about 15 l and the duct 32 is constituted by a pipe about 10 cm long and a diameter of about 5 cm.

[0018] The volume of the device 12 is not related to the consumer consumption. If the consumer for example asks for 15 l/min, the external water source has to be able to supply such flow or a higher one and the device 12 can for example have the dimensions of which above.

[0019] The water input duct 23 is placed to the higher extremity of the lower container 30 and the water exit duct 24 is placed at the lower extremity of the lower container 30. At the top of the upper container 31 the safety valve 13 is placed.

[0020] The safety valve 13 is preferably arranged at an activation pressure to avoid overpressure problem.

[0021] The preferable construction materials of the accumulation device 12 are the polymers that have characteristics of elevated mechanical, physics, chemical resistance that are proper of this type of devices, and they are of easy workmanship. For example, other materials such as iron, steel and light metal, can however also be used.

[0022] Being the materials of which above easily workable, and being the accumulation device 12 normally placed inside a high pressure washing apparatus, its form can be suitable for the available inside space, also substantially maintaining a form simile to a parallelepiped composed by one or more containers.

[0023] Its positioning related to the other elements of a washing apparatus is not critical, although it is preferable to place it so that its maximum water level is higher than the height of the input pump.

[0024] In a preferred embodiment of the accumulation device 12, in which it has been realized in polymer, a reinforcement 35 preferably metallic feedthrough and solidly transversally placed (parallel to the short edge of the parallelepiped) has been inserted to avoid the excessive deformation and possible breakup of the device 12. Such a reinforcement 35 is preferably constituted by a metal pipe (having an internal diameter of about 2-6 cm) opportunely fixed in a feedthrough hole made in the accumulation device 12. In this way it is possible to use the pipe as a hole for passage of electrical cables or used washing apparatus fluids.

[0025] More reinforcements 35 can also be used, also placed along other directions. Other stiffening forms of the accumulation device 12 are possible, for example one or more metallic containment bands.

[0026] The accumulation device 12 is able to guarantee a constant pressure supplying pumps of any type. Particularly it is able to supply to the pump a fluid at an approximately constant pressure approximately equal to the pressure available at its input. The air portion in pressure that is automatically created inside the accumulation device 12, at its connection to the water network allows to compensate at the pressure variations present in the water network itself.

[0027] Preferably, the accumulation device 12 does not have mechanical parts as floats for the control of the water. But it can be equipped with interception device such as floats, valves and electro valves for a possible system control.

[0028] Thanks to the pressure that it is created at its inside it is able to start the pump without applying drainage interventions.

[0029] There is the elimination (or however a notable

reduction) of the cavitation phenomenon, because the pump does not effect efforts to supply itself.

[0030] It does not ask for any maintenance because there are not elements inside or outside that condition its operation.

Claims

1. High pressure washing apparatus comprising:
 - an input duct (23) for introducing a fluid at a first pressure in said apparatus;
 - a pump (14) for receiving said fluid and supplying a fluid at a second pressure;
 - an output duct (22) for supplying said fluid at said second pressure to the outside;

characterized by comprising

 - a container (12) placed between said input duct (23) and said pump (14); said container (12) being at airtight and having a first volume portion (26) able to contain said fluid and a second volume portion (25) able to contain a compressible fluid.
2. High pressure washing apparatus according to claim 1 **characterized in that** said fluid is water and said compressible fluid is air.
3. High pressure washing apparatus according to claim 1 **characterized in that** said second pressure is higher than said first pressure.
4. High pressure washing apparatus according to claim 1 **characterized in that** said container (12) has a higher extremity and a lower extremity, said input duct (23) being placed at an intermediary height among said higher extremity and said lower extremity, and it has an output pipe (24) to supply said fluid to said pump (14), placed at its lower extremity.
5. High pressure washing apparatus according to claim 1 **characterized in that** said first volume portion (26) able to contain said fluid is contained in a first container (30) and said second volume portion (25) able to contain a compressible fluid is contained in a second container (31), said first container (30) is connected to said second container (31) through a duct (32), said input duct (23) being placed at the higher end of said first container (30), and it has an output pipe (24) to supply said fluid to said pump (14), placed to the lower end of said first container (30).
6. High pressure washing apparatus according to claim 5 **characterized in that** said first container (30) has a volume between the 50% and the 90%

of the total volume, said second container (31) has a volume between the 10% and the 50% of the total volume, said duct (32) has a volume between 1% and the 10% of the total volume.

5

7. High pressure washing apparatus according to claim 1 **characterized in that** said container (12) has a safety valve (13) placed at its higher extremity.

10

8. High pressure washing apparatus according to claim 1 **characterized in that** downstream said pump (14) it comprises a boiler (19) able to heat said fluid.

15

9. High pressure washing apparatus according to claim 1 **characterized in that** said container (12) comprises at least one reinforcement element (35) to avoid the deformation of said container (12).

20

10. High pressure washing apparatus according to claim 9 **characterized in that** said at least one reinforcement element (35) is constituted by a pipe placed in a passing-through hole made in said container (12).

25

30

35

40

45

50

55

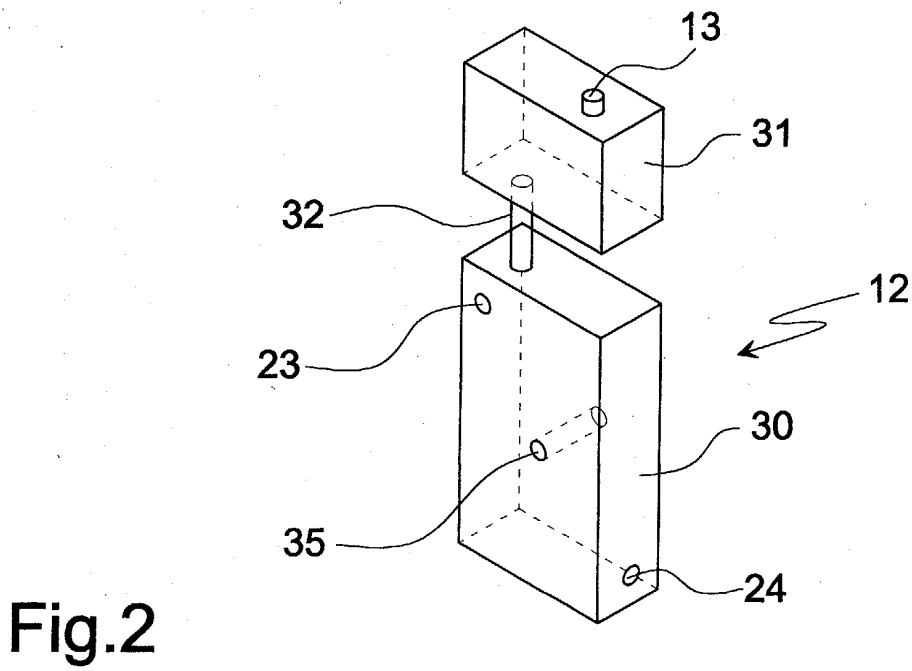
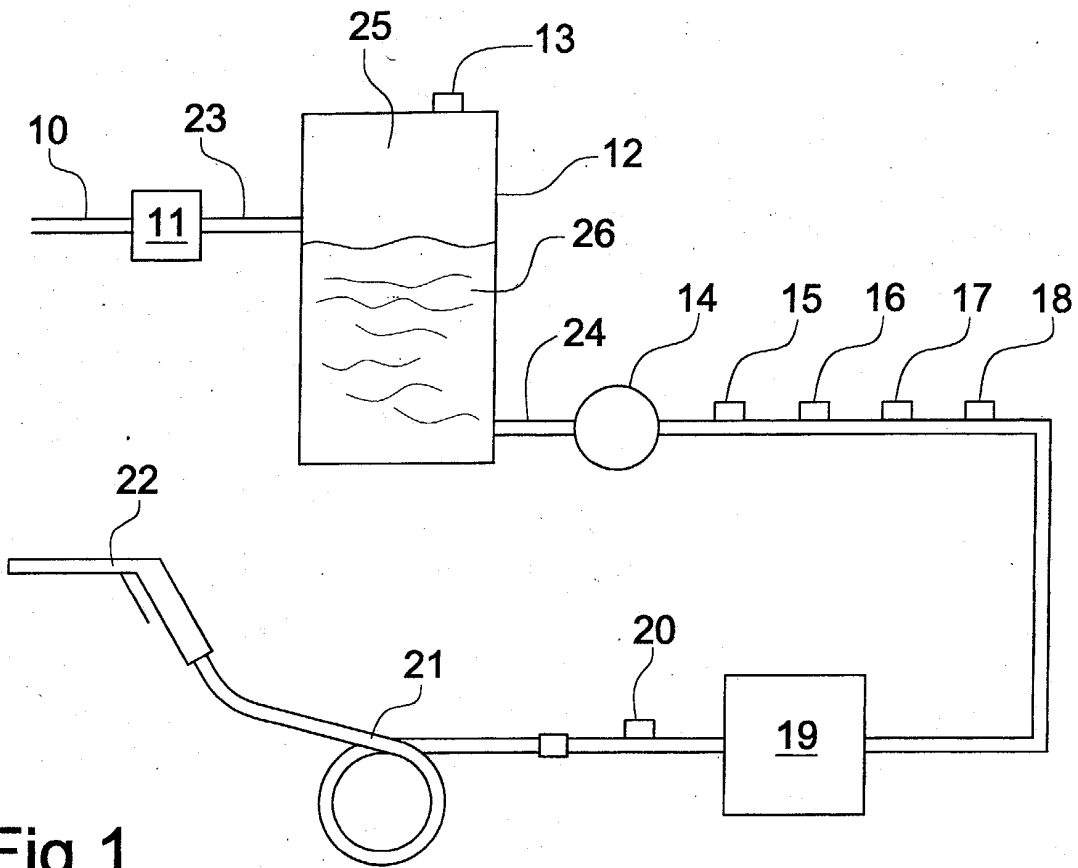



European Patent Office

EUROPEAN SEARCH REPORT

Application Number
EP 03 42 5072

DOCUMENTS CONSIDERED TO BE RELEVANT			
Category	Citation of document with indication, where appropriate, of relevant passages	Relevant to claim	CLASSIFICATION OF THE APPLICATION (Int.Cl.7)
X	DE 29 51 369 A (SCHUSTER PAUL) 2 July 1981 (1981-07-02)	1-3,5-10	B08B3/02
Y	* the whole document * ---	4	
Y	FR 2 369 879 A (STRAHMAN VALVES INC) 2 June 1978 (1978-06-02) * figure 1 * * page 2, line 29 - page 3, line 29 * ---	4	
A	GB 1 604 447 A (QUILL CHEMICALS LTD) 9 December 1981 (1981-12-09) * the whole document * -----	1	
The present search report has been drawn up for all claims			TECHNICAL FIELDS SEARCHED (Int.Cl.7)
			B08B
Place of search	Date of completion of the search	Examiner	
THE HAGUE	21 August 2003	Plontz, N	
CATEGORY OF CITED DOCUMENTS		T : theory or principle underlying the invention E : earlier patent document, but published on, or after the filing date D : document cited in the application L : document cited for other reasons & : member of the same patent family, corresponding document	
X : particularly relevant if taken alone Y : particularly relevant if combined with another document of the same category A : technological background O : non-written disclosure P : intermediate document			

EPO FORM 1503.03.82 (F04C01)

**ANNEX TO THE EUROPEAN SEARCH REPORT
ON EUROPEAN PATENT APPLICATION NO.**

EP 03 42 5072

This annex lists the patent family members relating to the patent documents cited in the above-mentioned European search report. The members are as contained in the European Patent Office EDP file on
The European Patent Office is in no way liable for these particulars which are merely given for the purpose of information.

21-08-2003

Patent document cited in search report		Publication date	Patent family member(s)	Publication date
DE 2951369	A	02-07-1981	DE 2951369 A1	02-07-1981
FR 2369879	A	02-06-1978	US 4089470 A	16-05-1978
			CA 1066743 A1	20-11-1979
			FR 2369879 A1	02-06-1978
			GB 1589413 A	13-05-1981
GB 1604447	A	09-12-1981	NONE	