



(12) **EUROPEAN PATENT APPLICATION**

(43) Date of publication:  
**11.08.2004 Bulletin 2004/33**

(51) Int Cl.7: **E04D 1/24, E04F 13/08**

(21) Application number: **04002189.1**

(22) Date of filing: **02.02.2004**

(84) Designated Contracting States:  
**AT BE BG CH CY CZ DE DK EE ES FI FR GB GR  
HU IE IT LI LU MC NL PT RO SE SI SK TR**  
Designated Extension States:  
**AL LT LV MK**

(72) Inventor: **Montresor, Gianfranco**  
**37136 Verona (IT)**

(74) Representative: **Savi, Alberto**  
**c/o CON LOR SPA,**  
**Via Amatore Sciesa, 9**  
**37122 Verona (IT)**

(30) Priority: **06.02.2003 IT VR20030014**

(71) Applicant: **Montresor, Gianfranco**  
**37136 Verona (IT)**

(54) **A covering structural shape carried out as one piece to be mounted on a building roof or wall**

(57) A new type of tile or covering element for a roof or wall is proposed. This new type of tile or covering is different from the conventional covering for it shows such a shape and size that it may cover the whole length of a roof or wall from the ridge of the roof to the border of the gutter as a one-piece element. It is possible to put the covering structural shape according to the present invention close to other equal coverings. The so-ob-

tained roof or wall is as resistant as possible to water infiltrations and bad weather and is very durable. Basically, the structural shape according to the present invention is carried out by extruding metal or synthetic materials or other suited materials. The structural shape (1) shows a bent back (2) which is connected through connecting faces (3, 10) with a horizontal base (4) which acts as a bearing surface on the roof.

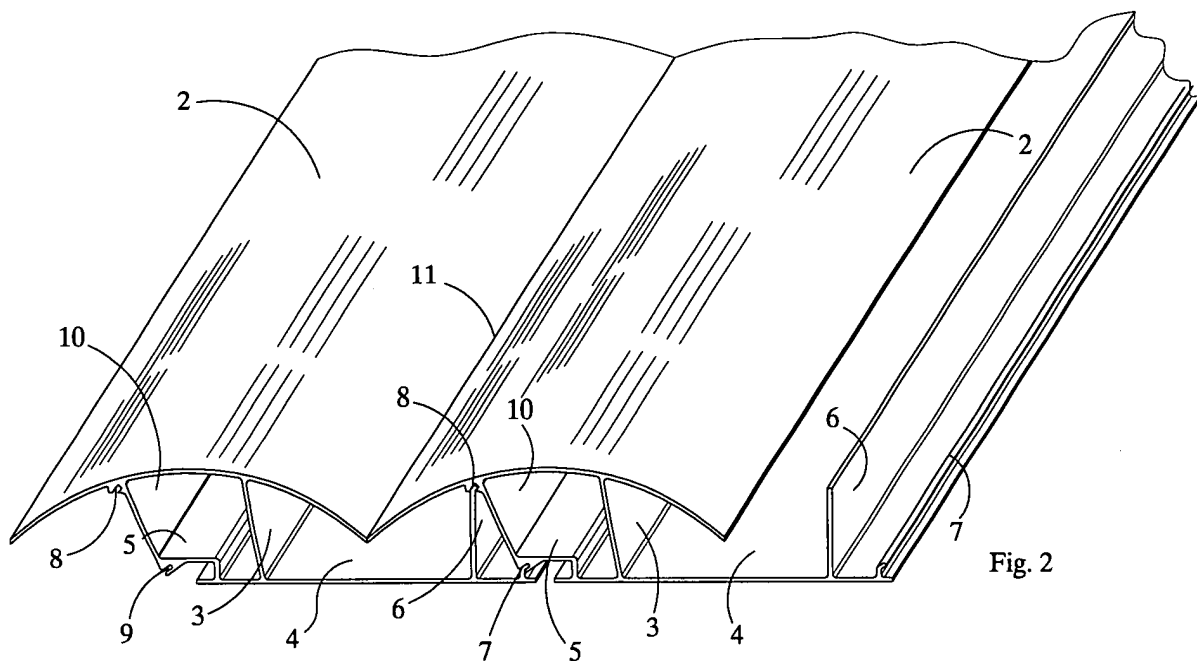

Fig. 2

## Description

**[0001]** The present industrial invention proposes a new covering structural shape carried out as a sole piece to be associated with other structural shapes of the same type to make a roof or wall covering or whatever kind of covering of external planes in the field of building.

**[0002]** In general, a new type of tile or covering element for a roof or wall is proposed. This new type of tile or covering is different from the conventional covering for it shows such a shape and size that it may cover the whole length of a roof or wall from the ridge of the roof to the border of the gutter as a sole piece. It is possible to put a covering structural shape according to the present invention close to other equal coverings. The so-obtained roof or wall is as resistant as possible to water infiltrations and bad weather and is very durable.

**[0003]** The structural type of a structural shape according to the present invention along with an appropriate choice of the structural shape materials make the covering much more resistant and durable than the prior art coverings and therefore, the structural shape in question is very advantageous.

**[0004]** As is known, the prior art discloses several techniques to obtain roof coverings. These techniques refer to the application of covering elements. In most cases, the covering elements are represented by the conventional tiles in terracotta which may show several shapes and are positioned in such a way as to obtain a resistant construction to bad weather as well as a sufficient duration.

**[0005]** When laying the conventional roofing tiles it is necessary to pay attention to some aspects, for instance the whole length of the pitch must be such a length that it is not necessary to cut the tiles of the last row on the ridge because the cut of the rear part of the tile would cause a removal of the coupling teeth on preventing a correct laying and a safe securing of these last elements.

**[0006]** In addition, depending on the pitch inclination the tiles may be simply put on the supporting roof lathing and then coupled with the supporting roof lathing. However, in case of bad weather, for instance strong wind, or in case of a great pitch inclination it is possible to rivet the tiles to the rood lathing through the suited hole which must be completely opened by means of suited tools.

**[0007]** It is to exclude a direct laying of the tiles on the underlayer as the tiles tend to slide owing to external causes such as vibrations, strong wind, etc. and therefore, it is necessary to fix a row of tiles every three or four rows (depending on the pitch inclination) with cement mortar or polyurethane foams. In this way, it is also possible to avoid a thin air flow under the tiles. This air flow could subject the whole roof covering to an excessive thermic and/or dynamic stress (upkeep of the roof).

**[0008]** In any case, the utilization of the conventional tiles is rather limited owing to their short duration. In ad-

dition, the tiles tend to displace. Generally speaking, the classical roof tile covering system does not offer a sufficient duration, stability and resistance to bad weather owing to water infiltrations caused by the displacements of the tiles or thermal shocks or hail storms.

**[0009]** All the aforesaid inconveniences make it necessary to effect a rather frequent upkeep which is very expensive.

**[0010]** Further, there is not a solution to cover building walls to make them resistant to bad weather and durable.

**[0011]** The aim of the present invention is to remove the above drawbacks by utilizing a new type of tile or covering for a roof or wall, this tile or covering being not made of terracotta but of more resistant materials such as metal materials (aluminium or copper) or synthetic materials (for instance, PVC or the like).

**[0012]** In addition, the present tile is made as a sole piece according to certain dimensional standards calculated between the roof ridge and the gutter border and shows suited structural shapes which permit a lateral surmounting between two adjacent tiles. In this way, a perfect tightness is obtained and water flows downward to the gutter and no water infiltrations occur.

**[0013]** Moreover, the tile according to the present invention is advantageous because it is produced by extrusion at a low cost so that it is possible its rapid diffusion on a large scale.

**[0014]** All the above aims and advantages are reached according to the present invention by a structural shape for a roof or wall covering, which structural shape is produced as a sole piece and is associated to other structural shapes of the same type to obtain a roof or wall covering in a building or the like, characterized in that it shows a bent back which is connected through suited connections with a horizontal bearing surface provided with fins and profiles which permit a mutual coupling of more structural shapes of the same type on their longitudinal borders in such a way as to obtain a consecutive multiple union of the backs.

**[0015]** Further features and details of the present invention will be better understood from the following specification which is given as a nonlimiting example on the hand of the accompanying drawings wherein:

Fig. 1 is a schematic perspective view in cross section of a roof covering structural shape as a whole according to the present invention;

Fig.2 is a schematic perspective view of more joined profiles according to the invention;

Fig. 3 is a schematic perspective view of a detail of the connecting point between two structural shapes, a fixing screw being inserted between them;

Fig. 4 is a schematic view showing a wall covering; Fig. 5 is a schematic perspective view of a further structural shape according to the invention.

**[0016]** With reference to the accompanying drawings, number 1 denotes a structural shape as a whole according to the invention. The structural shape is a covering element which is carried out as a one-piece element. The structural shape is connected with other structural shapes of the same type so as to obtain a roof or wall covering or whatever kind of building covering.

**[0017]** Basically, the structural shape according to the present invention is carried out by extruding metal or synthetic materials or other suited materials. The structural shape shows a bent back 2 which is connected through a first connecting face 3 with a horizontal base 4 which acts as a bearing surface on the roof.

**[0018]** In turn, the said horizontal base 4 is provided with fins and profiles which permit a mutual coupling of more structural shapes of the same type on their longitudinal borders in such a way as to obtain a consecutive multiple union of the backs.

**[0019]** More precisely, the horizontal base 4 extends laterally and is projecting to a certain extent from the border of the back 2. The horizontal base is provided on one side with a profile 5 which is shaped like an overturned "C" and on the other side, the horizontal base is provided with two vertical fins 6, 7. Fin 6 is higher than fin 7.

**[0020]** The inside of back 2 is provided with a grooved projection 8 while profile 5 is provided with a grooved projection 9.

**[0021]** The end of fin 6 is slightly bent in order to be included in the grooved projection 8 which is bent. The end of fin 7 is bent, as well in order to be included in the grooved projection 9.

**[0022]** As it can be seen, there is a second reinforcement connecting face 10 which cooperates with the connecting face 3 and connects the profile 5 with the inner part of the back 2. The connecting face 10 makes the product in question stronger and permits to reach a higher quality of the extruded product.

**[0023]** In addition, the connected face 3 is slightly inclined, just a few degrees, toward the centre of the back 2. This measure is necessary for the following reason: in case of a vertical arrangement of the panel the small quantities of water that could flow in the inside of the profile through the connecting line 11 are canalized toward the outer part of the structural shape and not toward the inside so that a better tightness is obtained against the infiltrations.

**[0024]** The structural shape has been described according to one embodiment. A plurality of identical structural shapes are put side by side in succession longitudinally in such a way as to remain stable and mutually supported.

**[0025]** In fact, as it can be seen in Fig. 2, when two structural shapes are put side by side, the vertical higher fin 6 of the first structural shape inserts in the grooved projection 8 of the second structural shape while the shorter fin 7 inserts in the grooved projection 9 of the overturned C-shaped profile 5.

**[0026]** According to a further embodiment the structural shape shows a configuration as represented in Fig. 5.

**[0027]** For the mounting of the said structural shapes it is necessary to effect a slight pressure in order that the fins insert in their respective grooved projections and a certain tightness is obtained. However, in case of an intervention of upkeep, it is possible to remove a structural shape from another one.

**[0028]** In this situation, the lateral borders of two adjacent backs 2 are very close almost to touch each other and prevent rain water from penetrating in the inside.

**[0029]** In any case, if rain water penetrate between two structural shapes, it flows in the inner channels of the structural shapes to reach the gutter channel through which water is expelled.

**[0030]** As said, the so-described structural shapes are produced according to standard sizes to cover the whole length of the roof pitch but it is also possible that the said structural shapes are cut to measure according to the specific size of the roof.

**[0031]** The structural shapes according to the present invention can be put on any roof surface showing any inclination because the horizontal base is fixed through any kind of screws 12 (Fig. 3).

**[0032]** As an advantage, the so-described structural shapes may be mounted without a waterproof sheath since the tightness against water, wind and bad weather is guaranteed for a long time.

**[0033]** The structural shapes avoid any possibility of water infiltration and are self-ventilated because the air can pass through the inner channels.

**[0034]** The peculiar constructive features of the structural shapes according to the present invention avoid any possibility of removal or displacement by the wind. Even a very strong wind is not able to remove the structural shapes that are fixed by means of screws 12. The screws may show whatever shape and size. Also the fins 6, 7 and the respective grooved projections 8 and 9 make the structural shape more resistant to wind.

**[0035]** Concerning the appearance, the structural shapes in question show a shape similar to the conventional roofing tiles. Also the colour of the structural shapes according to the present invention may be the same as the conventional roofing tiles since, as previously said, the materials to be utilized for the production of the structural shapes may be whatever materials containing for instance aluminium, copper, PVC or the like. These materials are durable and resistant to the corrosion and bad weather.

**[0036]** The structural shapes according to the present invention are mounted in a very simple way and may show any lengths, for instance several meters depending on the roof or wall size. The structural shapes do not show any outer holes or screws or rivets so that it is possible to obtain a perfect outer homogeneity and continuity.

**[0037]** Finally, it is possible to anodize or paint or var-

nish or treat the structural shapes in question in any way and with any kind of finishing substance in order to make them more resistant to bad weather as well as more pleasant to look at.

**[0038]** A skilled artisan could modify the above described, represented structural shapes, for instance by changing the shape of the borders or the shape of the coupling profiles or the shape of the back 2 as these shapes may be whatever shapes depending on the constructive and aesthetic requirements in order to obtain solutions that are to be considered as included in the scope of protection of the invention as further defined, in its peculiar characteristics, in the following claims.

### Claims

1. Structural shape for a building roof or wall covering, which structural shape is produced as one piece and is associated to other structural shapes of the same type to obtain a roof or wall covering in a building or the like, **characterized in that** it shows a bent back which is connected through suited connections with a horizontal bearing base provided with fins and profiles which permit a mutual coupling of more structural shapes of the same type on their longitudinal borders in such a way as to obtain a consecutive multiple union of the backs.
2. Structural shape for a building roof or wall covering or the like as claimed in the foregoing claim, **characterized in that** the structural shape shows a bent back (2) which is connected through connecting faces (3, 10) with a horizontal base (4) which acts as a bearing surface on the roof.
3. Structural shape for a building roof or wall covering or the like as claimed in the foregoing claims, **characterized in that** the said back (2) may show a bent section or any other shape according to the functional and aesthetic need.
4. Structural shape for a building roof or wall covering or the like as claimed in the foregoing claims, **characterized in that** the said horizontal base (4) is provided with fins and profiles which permit a mutual coupling of more structural shapes of the same type on their longitudinal borders in such a way as to obtain a consecutive multiple union of the structural shapes.
5. Structural shape for a building roof or wall covering or the like as claimed in the foregoing claims, **characterized in that** it may be put on any roof surface showing any inclination because the horizontal base (4) is fixed through screws (12).
6. Structural shape for a building roof or wall covering or the like as claimed in the foregoing claims, **characterized in that** the said horizontal base (4) extends laterally and is projecting to a certain extent from the border of the back (2); the horizontal base is provided on one side with a profile (5) which is shaped like an overturned "C" and on the other side, the horizontal base is provided with two vertical fins (6, 7), fin (6) being higher than fin (7).
7. Structural shape for a building roof or wall covering or the like as claimed in the foregoing claims, **characterized in that** the inside of the back (2) is provided with a grooved projection (8) while profile (5) is provided with a grooved projection (9).
8. Structural shape for a building roof or wall covering or the like as claimed in the foregoing claims, **characterized in that** for the arrangement of a structural shape close to another one, the end of fin (6) is slightly bent in order to be included in the grooved projection (8) which is also bent; the end of fin (7) is also bent in order to be included in the grooved projection (9).
9. Structural shape for a building roof or wall covering or the like as claimed in the foregoing claims, **characterized in that** it is possible to anodize or paint or varnish or treat the structural shapes in question in any way and with any kind of finishing substance in order to make them more resistant to bad weather as well as more pleasant to look at.
10. Structural shape for a building roof or wall covering or the like as claimed in the foregoing claims, **characterized in that** the structural shapes are produced according to standard sizes to cover the whole length of the roof pitch but it is also possible that the said structural shapes be cut to measure according to the specific size of the roof to be covered.
11. Structural shape for a building roof or wall covering or the like as claimed in the foregoing claims, **characterized in that** the shape of the coupling borders or profiles may be whatever shape suited to obtain a mutual engaging.

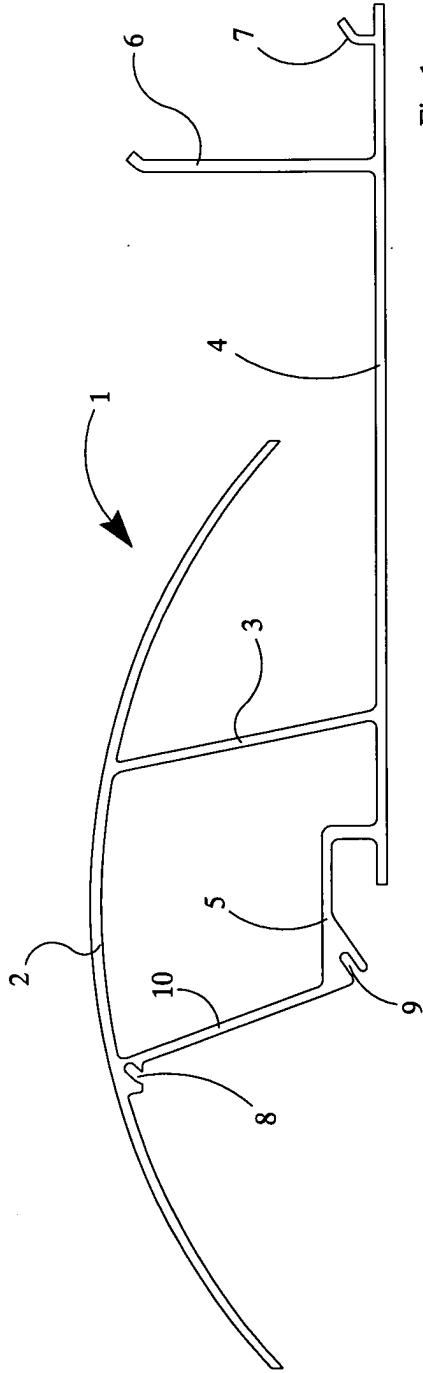

Fig. 1

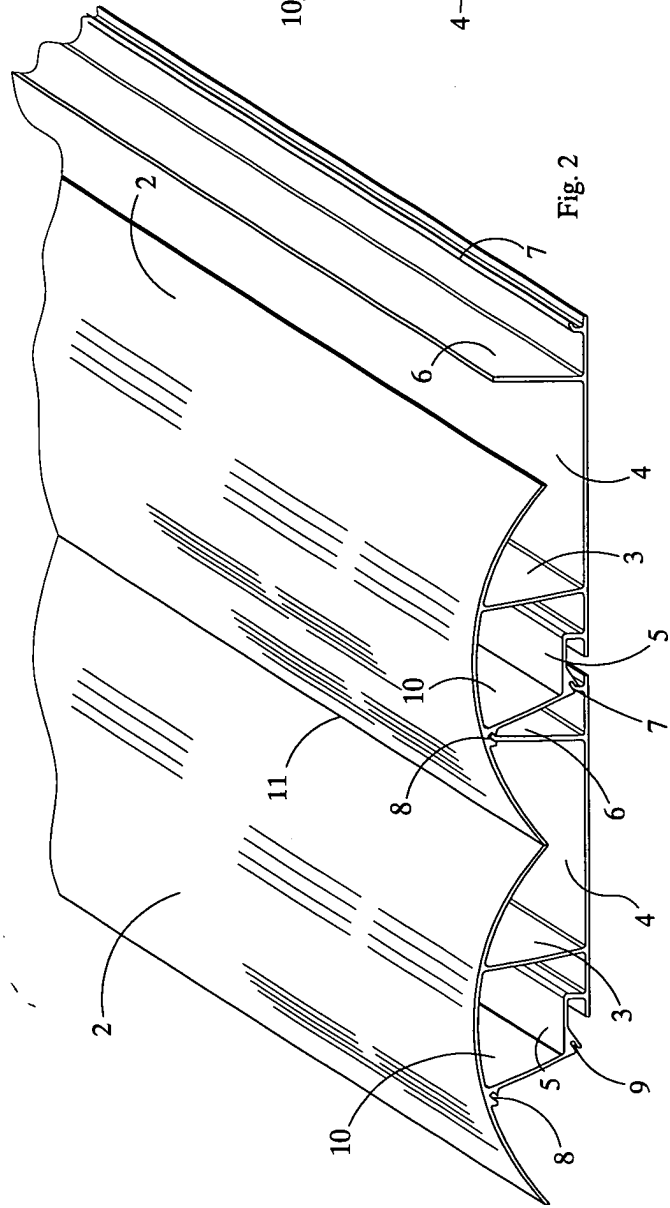

Fig. 2

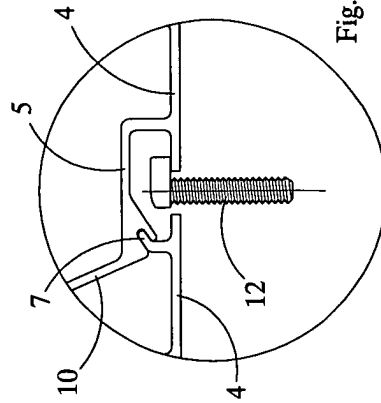

Fig. 3

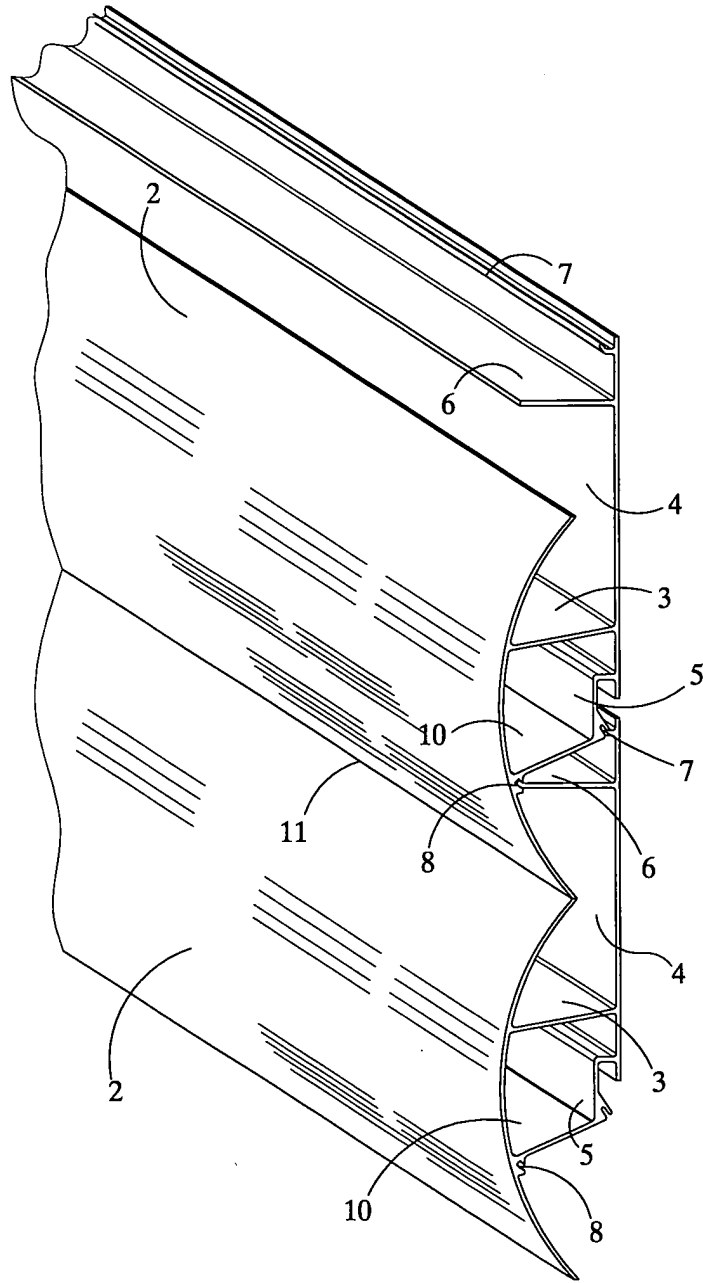

Fig. 4

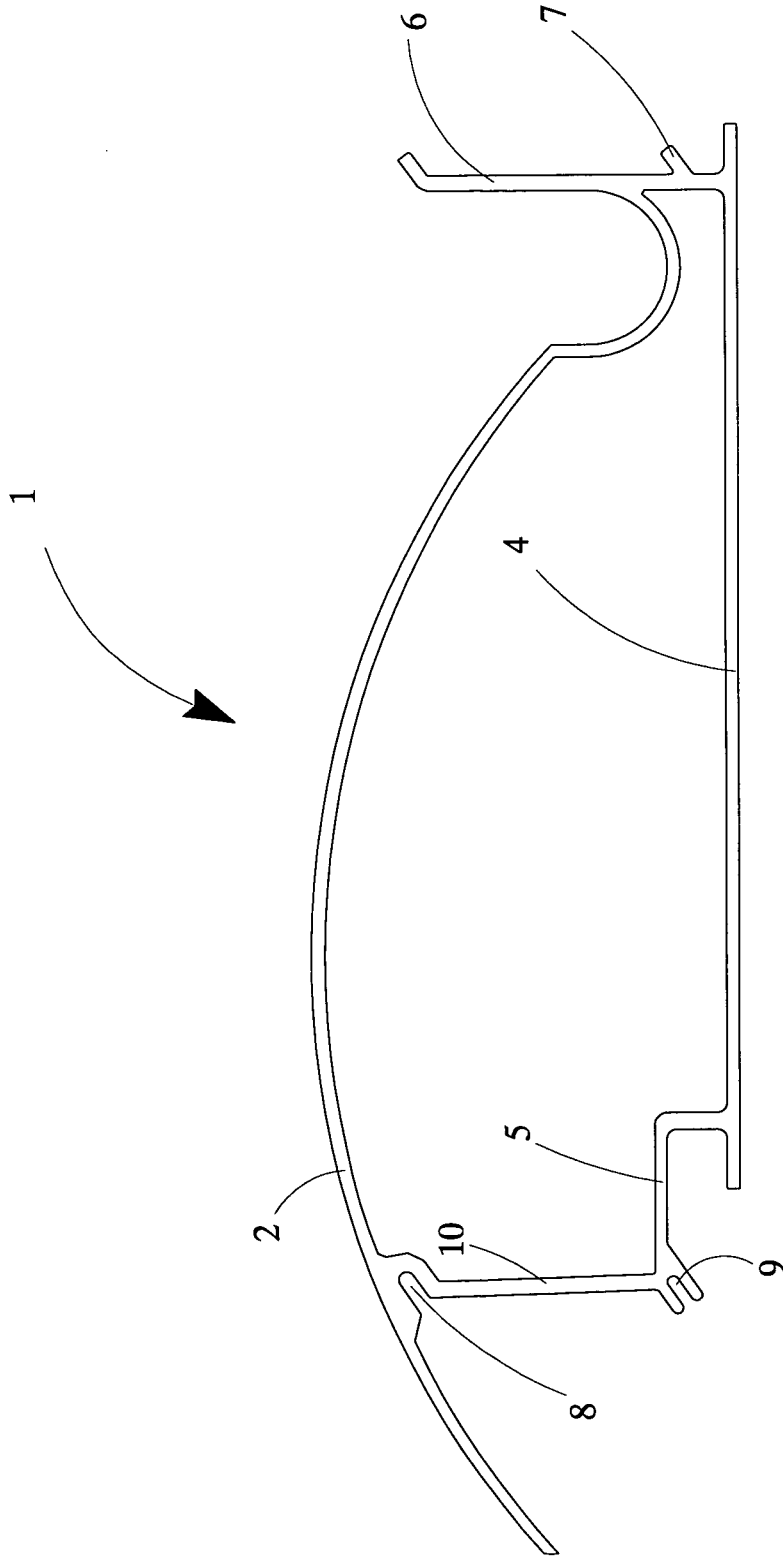

Fig. 5



European Patent  
Office

EUROPEAN SEARCH REPORT

Application Number  
EP 04 00 2189

DOCUMENTS CONSIDERED TO BE RELEVANT			
Category	Citation of document with indication, where appropriate, of relevant passages	Relevant to claim	CLASSIFICATION OF THE APPLICATION (Int.Cl.7)
X	PATENT ABSTRACTS OF JAPAN vol. 2000, no. 18, 5 June 2001 (2001-06-05) & JP 1 094152 A (IG TECH RES INC), 12 April 1989 (1989-04-12) * abstract; figures 3,7 *	1-5,9-11	E04D1/24 E04F13/08
X	DE 100 27 408 A (EDMEIER KARIN) 6 December 2001 (2001-12-06) * figures 9,21 *	1-5,9-11	
X	FR 660 504 A (RIVIERE, CHARLES) 12 July 1929 (1929-07-12) * the whole document *	1-5,9-11	
			TECHNICAL FIELDS SEARCHED (Int.Cl.7)
			E04D E04F
The present search report has been drawn up for all claims			
Place of search		Date of completion of the search	Examiner
Munich		14 May 2004	Rosborough, J
CATEGORY OF CITED DOCUMENTS			
X : particularly relevant if taken alone Y : particularly relevant if combined with another document of the same category A : technological background O : non-written disclosure P : intermediate document		T : theory or principle underlying the invention E : earlier patent document, but published on, or after the filing date D : document cited in the application L : document cited for other reasons & : member of the same patent family, corresponding document	

EPO FORM 1503 03.82 (P/04C01)

**ANNEX TO THE EUROPEAN SEARCH REPORT  
ON EUROPEAN PATENT APPLICATION NO.**

EP 04 00 2189

This annex lists the patent family members relating to the patent documents cited in the above-mentioned European search report. The members are as contained in the European Patent Office EDP file on  
The European Patent Office is in no way liable for these particulars which are merely given for the purpose of information.

14-05-2004

Patent document cited in search report		Publication date	Patent family member(s)	Publication date
JP 1094152	A	12-04-1989	NONE	
DE 10027408	A	06-12-2001	DE 10027408 A1	06-12-2001
FR 660504	A	12-07-1929	NONE	