



(12) **EUROPEAN PATENT APPLICATION**

(43) Date of publication:
13.10.2004 Bulletin 2004/42

(51) Int Cl.7: **B61L 5/18**

(21) Application number: **04425231.0**

(22) Date of filing: **31.03.2004**

(84) Designated Contracting States:
**AT BE BG CH CY CZ DE DK EE ES FI FR GB GR
HU IE IT LI LU MC NL PL PT RO SE SI SK TR**
Designated Extension States:
AL LT LV MK

(72) Inventors:
• **Cappellini, Mario**
51100 Pistoia (IT)
• **Cappellini, Roberto**
51016 Montecatini Terme (Pistoia) (IT)

(30) Priority: **08.04.2003 IT fi20030097**

(74) Representative: **Martini, Lazzaro**
Studio Brevetti Ing. Dr. Lazzaro Martini s.r.l.
Via dei Rustici 5
50122 Firenze (IT)

(71) Applicant: **Elettromeccanica CM S.r.l.**
51034 Serravalle Pistoiese (PT) (IT)

(54) **Light signal, especially for use in the railroad field, as an advance starting or call signal**

(57) The invention relates to a railroad apparatus for advance starting light signal, that is, a signal of a type constituted by means of optical groups horizontally combined to project, in the direction of an incoming train, two fixed or blinking lights, associable with a starting signal

authorizing the passage of a train, characterized in that it comprises, for each of said optical groups, at least one matrix (1) of luminous elements or sectors electrically connected in parallel, each luminous sector comprising one or more blue colour-light sources (10).

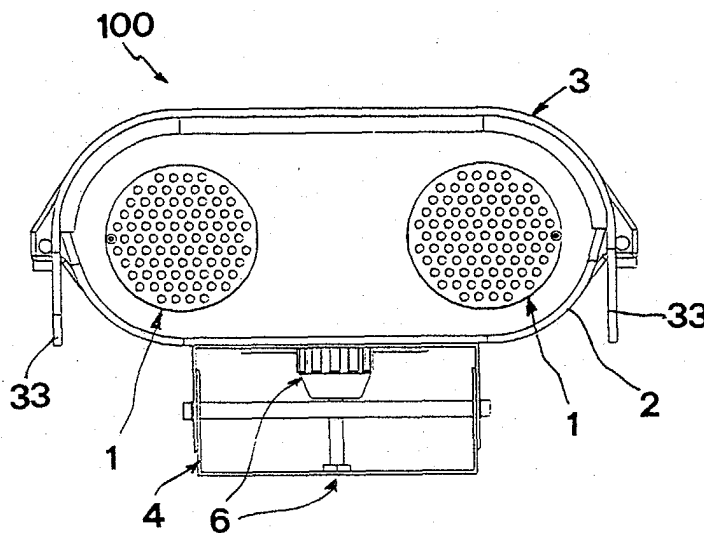

Fig. 1

Description

[0001] The present invention refers to a railroad advance starting light signal, that is, a signal of a type similar to the conventional one known in the railroad signalisation technique as a call signal.

[0002] The traditional call signal is constituted by means of two lamps horizontally combined and usually fixed, on the same pole (or post, as it is called in technical jargon) that carries the lamps for first class protection signal therebelow.

The call signal is normally off or deactivated; when activated, it projects, in the direction of the incoming train, two milk-white blinking lights which authorize the train to enter the station, thereby overriding the relevant protection signal which is disposed in off-state or stop mode.

[0003] The light signals of this type have many drawbacks.

[0004] One drawback relates to the fact that in case of a burnt-out lamp, the relevant useful signal cannot be generated; in fact, when a lamp burns out, after a service life no longer than 700 hours for this type of signal, these known devices are unable to supply all the same the required information, thereby compromising both the regularity and safety of the operation.

Moreover, the known devices result subjected, in a more or less variable extent, which depends on the constructional characteristics, to the so-called "ghost effect". The latter is a phenomenon of essentially optical nature by which the optical unit - intended to emit the light signal by projecting white or otherwise coloured light - although switched off, is able all the same to project a beam of light following the input and subsequent reflection of foreign radiations (for example, coming from artificial sources like railroad or road lamps and lights, signs, natural sources like sun rays) in the signal-projecting direction. Obviously, an event of such nature would dangerously prejudice the recognition and interpretation of the signals by the train's staff.

[0005] The main object of the present invention is to provide a new type of signal to be associated, for example, with a starting signal of first class, or at least to greatly reduce the above said drawbacks.

[0006] This result has been achieved, according to the invention, by adopting the idea of making an apparatus having the features disclosed in the claim 1. Further characteristics being set forth in the dependent claims.

[0007] The present invention makes it possible to greatly increase the reliability and thus the operation safety of this type of signal apparatus and to avoid the onset of the "ghost effect".

Moreover, an apparatus according to the present invention is relatively simple to make and cost-effective in relation to the its performance.

[0008] These and other advantages and characteristics of the invention will be best understood by anyone

skilled in the art from a reading of the following description in conjunction with the attached drawings given as a practical exemplification of the invention, but not to be considered in a limitative sense, wherein:

- Fig. 1 is an elevation front view of an apparatus according to the invention;
- Figs. 2 and 3 are, respectively, a top view and a side view of the apparatus of Fig. 1 when in use;
- Figs. 4 and 5 show the apparatus of the preceding figures in views similar to those of Figs. 2 and 3, and without a relevant covering guard; and
- Fig. 6 is an operational electric diagram relating to a matrix which defines an optical group, said matrix being made up of sectors connected in parallel and consisting of in-series LEDs.

[0009] Reduced to its basic structure, and reference being made to the figures of the attached drawings, an apparatus 100 according to the invention comprises a pair of optical groups, each of which is made up of a matrix 1 of luminous elements or sectors connected electrically to each other.

[0010] In the example illustrated in the figures of the accompanying drawings, the light advance starting signal apparatus 100 in question comprises two matrixes of blue-coloured light elements disposed horizontally side-by-side.

[0011] Advantageously, each light element or sector 1 consists of one or more blue-coloured light sources 10 connected in series to each other.

[0012] The apparatus 100 provides for using two matrixes 1 with eight sectors in the whole, five of which are made up of eleven LEDs in-series, and the other three consisting of ten LEDs also in series, the said sectors being in turn connected in parallel for a total of 85 LEDs.

[0013] Shown in Fig. 6 is an electric diagram of a matrix with m sectors in parallel, each of which consists of n LEDs in series. Provided on each sector is a relevant limiting resistance (R_1, \dots, R_m) and n LEDs ($D_{1,1}, \dots, D_{m,n}$).

[0014] Each LED may be of blue light-type with a typical light intensity of 2.6 cd at 20 mA, and angle of emission of $\pm 6.5^\circ$ with respect to its optical axis.

The light intensity on the optical axis is higher than 80 cd.

[0015] With reference in particular to Figs. 1-5, the apparatus 100 comprises a containment structure consisting of a base 2 and a lid 3 protruding frontally (and sideways with wings 33) so as to define a screen or shield.

The containment structure being possibly made of foamed polycarbonate. The front part 5 of the structure of apparatus 100 is downwardly inclined by an angle α of about 10° , so as to avoid the reflexes of the sun light towards the train's staff. On said front part, supported by a relevant fixing ring nut, are two plano-lenses 8 made of plastic material and which can have the dual function of protective means and optical filter.

[0016] The base 2 is mounted on a corresponding

support 4 allowing it to be fixed to a supporting post or pole (not shown), in correspondence of starting signal of first class, and which provides for an inlet 6 for relevant power cables (not shown) to be connected to a terminal block 7 inside the containment structure of the apparatus 100.

[0017] The matrixes 1 of LEDs 10, moreover, may be supported by a heat sink 9 of finned aluminium, with consequent advantages from the thermal point of view.

[0018] In place of the above indicated blue-light LEDs, LEDs can be used which project white light with different trichromatic coordinates by using coated glass or dichroic blue filters located in front of the LEDs so as to cause the light to take up the desired blue colour.

[0019] A light signal apparatus according to the invention is characterized, as above mentioned, by a high reliability.

The description that follows refers in fact to the reliability obtained from a signal apparatus according to the invention, comprising a matrix of LEDs arranged in sectors (or branches) in parallel, each sector including one or more LEDs in series. This special arrangement of the LEDs allows a significant increase of the reliability and availability of the matrix, inasmuch as the individual LEDs are subdivided into more sectors connected in parallel to each other and, in case of any failure of any of them, the signal results still operative and efficient although with less luminosity.

[0020] As for the reliability of a signal apparatus according to the invention, comprising a matrix of LEDs arranged in sectors in parallel, each sector including one or more LEDs in series, experimental tests have shown that this arrangement allows a significant increase of the reliability and availability of each of the three optical groups (equal to each other) that form the light signal apparatus. The particular embodiment and technology being used actually bring about a very long average life; by way of non limiting example, such length can be expected of over 20 years.

[0021] It should be apparent that the maintenance signal systems result therefore economical as far as the costs and organization of the maintenance activity are concerned.

For example, while the traditional lamps are replaced about 4 times in a year, the present invention would allow a system to be in operation for over 20 years.

[0022] By using a matrix of LEDs or equivalent light sources as above described, it is avoided to make use of optical components like mirrors, prisms, colour filters or others, which may alter the optical path and/or the colour of the light rays produced by external sources and coming back to the observer ("ghost effect").

Claims

1. A railroad apparatus for advance starting light signal, that is, a signal of a type constituted by means

of optical groups horizontally combined to project, in the direction of an incoming train, two fixed or blinking lights, associable with a starting signal authorizing the passage of a train, **characterized in that** it comprises, for each of said optical groups, at least one matrix (1) of luminous elements or sectors electrically connected in parallel, each luminous sector comprising one or more blue colour-light sources (10).

2. Light signal apparatus according to claim 1, **characterized in that** each light sector comprises at least two sources (10) connected in series.

3. Light signal apparatus according to claims 1 and 2, **characterized in that** each light sources (10) is made up of one LED.

4. Light signal apparatus according to claim 3, **characterized in that** the said matrix (1) comprises eight light in-parallel sectors, each of which comprises at least two LEDs connected in series.

5. Light signal apparatus according to claim 4, **characterized in that** the said matrix (1) comprises eight light in-parallel sectors, five of which comprise eleven LEDs connected in serie and three of which comprise ten LEDs connected in series.

6. Light signal apparatus according to one or more preceding claims, **characterized in that** the said light sources (10) are LEDs of blue-light type having a typical light intensity of 3.7 cd at 20 mA, and angle of emission of $\pm 6.5^\circ$ with respect to their optical axis.

7. Light signal apparatus according to one or more claims 1 to 5, **characterized in that** the said light sources (10) are LEDs suited for projecting a light of white colour and associated with filters able to cause the light emitted by the LEDs to take up a blue colour.

8. Light signal apparatus according to one or more preceding claims, **characterized in that** it comprises lenses (8), disposed downstream of said light sources (10) to be crossed by the light of the latter and inclined downwardly to limit the reflexes.

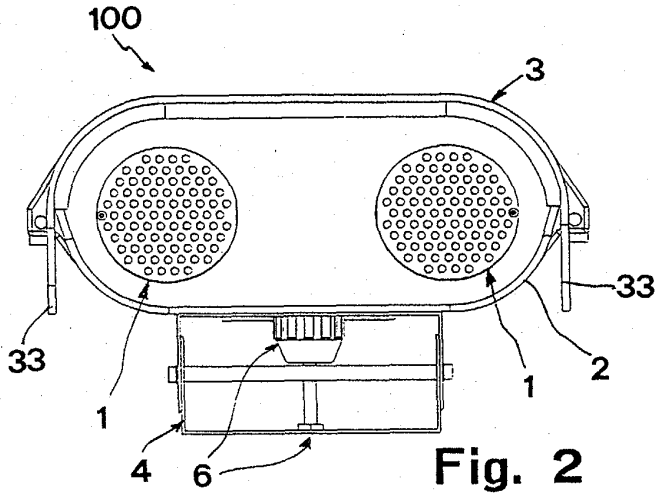

Fig. 1

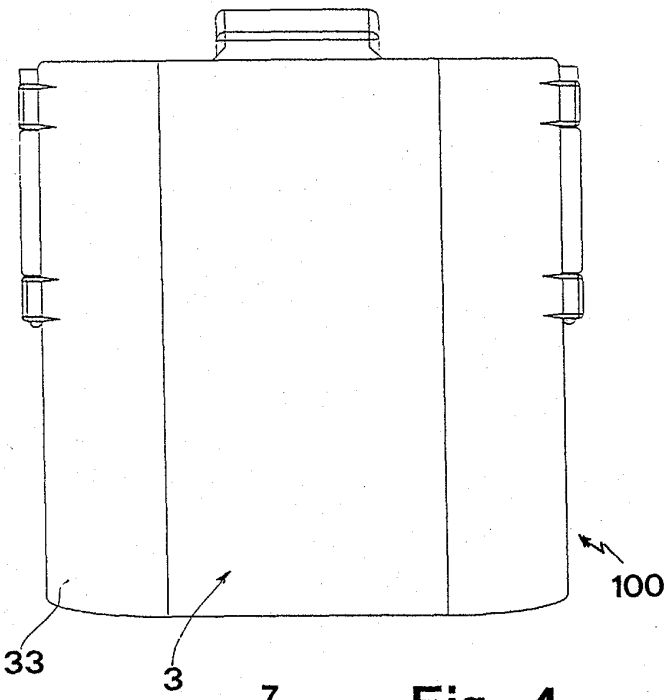

Fig. 2

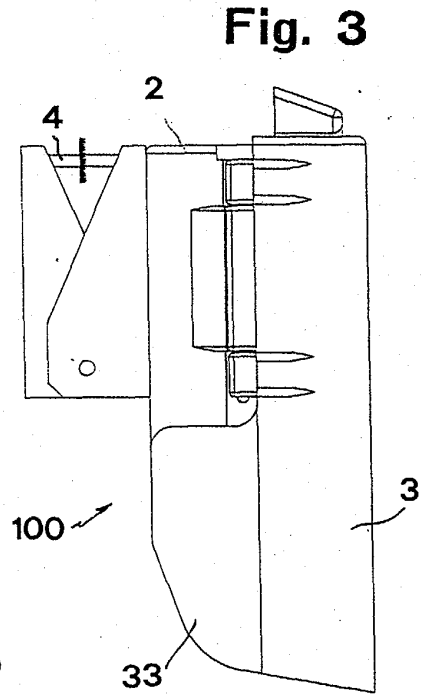

Fig. 3

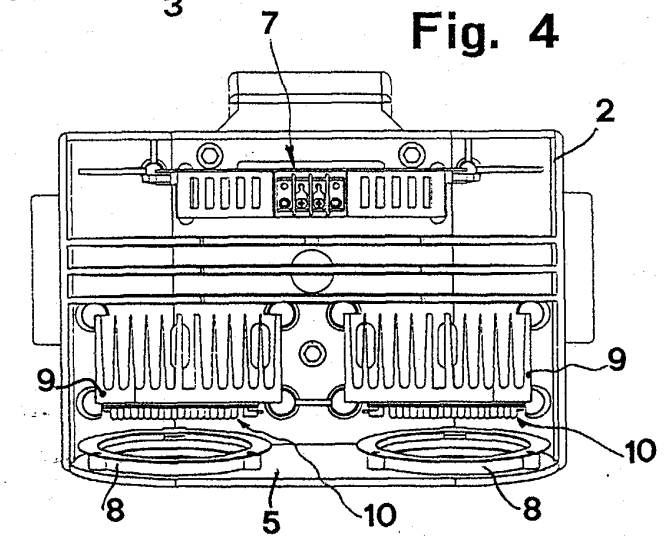

Fig. 4

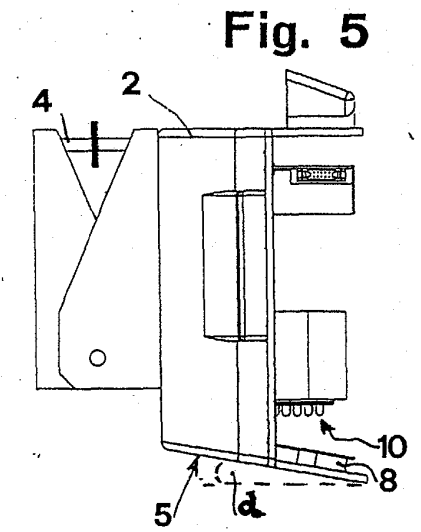

Fig. 5

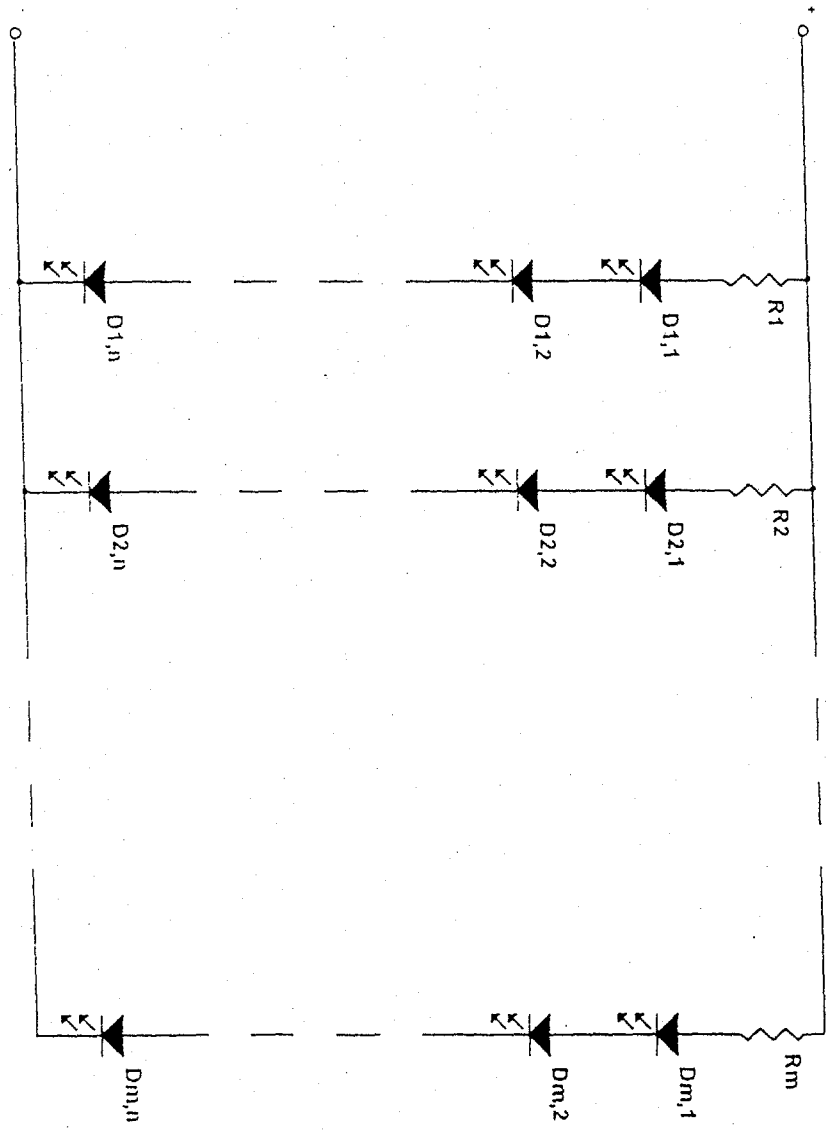

Fig. 6



European Patent
Office

EUROPEAN SEARCH REPORT

Application Number
EP 04 42 5231

DOCUMENTS CONSIDERED TO BE RELEVANT			
Category	Citation of document with indication, where appropriate, of relevant passages	Relevant to claim	CLASSIFICATION OF THE APPLICATION (Int.Cl.7)
X	GB 2 329 011 A (HOWELLS RAILWAY PRODUCTS LIMIT) 10 March 1999 (1999-03-10) * page 2, line 14 - line 24 * * page 3, line 29 - page 5, line 7 * * page 7, line 20 - line 25 * * page 10, line 24 - page 13, line 17 * * figures 2,4 * -----	1-8	B61L5/18
X	GB 2 356 694 A (DORMAN TRAFFIC PRODUCTS LTD) 30 May 2001 (2001-05-30) * page 1, line 20 - page 3, line 7 * * page 8, line 1 - page 10, line 6 * * page 14, line 15 - page 16, line 18 * * figures 3,5,7 * -----	1-8	
A	EP 0 713 999 A (SIEMENS INTEGRA VERKEHRSTECHNIK AG) 29 May 1996 (1996-05-29) * column 4, line 40 - line 44 * -----	1-8	
A	DANIEL WURMSER: "Les Signalisations Européennes - L'Italie" CHEMINS DE FER, vol. 1997, no. 04-05, 1997, pages 18-20, XP002288638 PARIS * page 19; figure 5 * * page 20, column 2 * -----	1-8	TECHNICAL FIELDS SEARCHED (Int.Cl.7) B61L G08G F21S F21V G02B
A	WO 95/12512 A (SIEMENS INTEGRA VERKEHRSTECHNI) 11 May 1995 (1995-05-11) * page 2, line 14 - page 3, line 6 * * figure 1 * -----	1-8	
A	US 5 663 719 A (LEWIS DAVID D ET AL) 2 September 1997 (1997-09-02) * column 4, line 40 - column 5, line 42 * * figures 2-5 * -----	1-8	
----- -/--			
The present search report has been drawn up for all claims			
Place of search Munich		Date of completion of the search 15 July 2004	Examiner Massalski, M
CATEGORY OF CITED DOCUMENTS X : particularly relevant if taken alone Y : particularly relevant if combined with another document of the same category A : technological background O : non-written disclosure P : intermediate document		T : theory or principle underlying the invention E : earlier patent document, but published on, or after the filing date D : document cited in the application L : document cited for other reasons ----- & : member of the same patent family, corresponding document	

EPO FORM 1503 03.82 (P04C01)



European Patent
Office

EUROPEAN SEARCH REPORT

Application Number
EP 04 42 5231

DOCUMENTS CONSIDERED TO BE RELEVANT			
Category	Citation of document with indication, where appropriate, of relevant passages	Relevant to claim	CLASSIFICATION OF THE APPLICATION (Int.Cl.7)
A	DE 198 24 562 A (TIEFENBACH GMBH) 10 December 1998 (1998-12-10) * the whole document *	1-8	
A	----- MICHAEL ZABEL, JÖRG LIEBSCHER: "LED - Eine neue Generation von Lichtquellen für eisenbahnsignale" SIGNAL + DRAHT., vol. 2000, no. 09, September 2000 (2000-09), pages 31-33, XP009033674 DETELZLAFF VERLAG GMBH. DARMSTADT. * the whole document *	1	
A	----- DD 118 334 A (LEIPOLD, MARTIN) 20 February 1976 (1976-02-20) * the whole document *	1	
P,A	----- EP 1 371 540 A (TECNOLOGIE MECCANICHE S R L) 17 December 2003 (2003-12-17) * paragraphs [0015] - [0028] * * paragraph [0054] *	1-8	
The present search report has been drawn up for all claims			TECHNICAL FIELDS SEARCHED (Int.Cl.7)
Place of search		Date of completion of the search	Examiner
Munich		15 July 2004	Massalski, M
<p>CATEGORY OF CITED DOCUMENTS</p> <p>X : particularly relevant if taken alone Y : particularly relevant if combined with another document of the same category A : technological background O : non-written disclosure P : intermediate document</p> <p>T : theory or principle underlying the invention E : earlier patent document, but published on, or after the filing date D : document cited in the application L : document cited for other reasons</p> <p>..... & : member of the same patent family, corresponding document</p>			

EPO FORM 1503 03_82 (P/4C01)

**ANNEX TO THE EUROPEAN SEARCH REPORT
ON EUROPEAN PATENT APPLICATION NO.**

EP 04 42 5231

This annex lists the patent family members relating to the patent documents cited in the above-mentioned European search report. The members are as contained in the European Patent Office EDP file on
The European Patent Office is in no way liable for these particulars which are merely given for the purpose of information.

15-07-2004

Patent document cited in search report		Publication date	Patent family member(s)	Publication date
GB 2329011	A	10-03-1999	AT 236821 T	15-04-2003
			AU 8876998 A	22-03-1999
			DE 69813255 D1	15-05-2003
			DE 69813255 T2	25-03-2004
			EP 1012023 A1	28-06-2000
			ES 2197498 T3	01-01-2004
			WO 9911498 A1	11-03-1999

GB 2356694	A	30-05-2001	GB 2390669 A ,B	14-01-2004

EP 0713999	A	29-05-1996	EP 0713999 A1	29-05-1996

WO 9512512	A	11-05-1995	AT 170472 T	15-09-1998
			WO 9512512 A1	11-05-1995
			DE 59406833 D1	08-10-1998
			DK 678078 T3	07-06-1999
			EP 0678078 A1	25-10-1995
			NO 951743 A	05-07-1995

US 5663719	A	02-09-1997	US 5457450 A	10-10-1995

DE 19824562	A	10-12-1998	DE 19824562 A1	10-12-1998
			DE 29824085 U1	31-05-2000

DD 118334	A	20-02-1976	DD 118334 A1	20-02-1976

EP 1371540	A	17-12-2003	IT RM20020331 A1	12-12-2003
			EP 1371540 A2	17-12-2003
