



(12) **EUROPEAN PATENT APPLICATION**

(43) Date of publication:
10.11.2004 Bulletin 2004/46

(51) Int Cl.7: **E21B 19/16**

(21) Application number: **04103600.5**

(22) Date of filing: **17.11.2000**

(84) Designated Contracting States:
DE FR GB NL

(72) Inventor: **Pietras, Bernd-Georg**
30900 Wedemark (DE)

(30) Priority: **26.11.1999 GB 9927825**

(74) Representative: **Talbot-Ponsonby, Daniel**
Marks & Clerk
4220 Nash Court
Oxford Business Park South
Oxford OX4 2RU (GB)

(62) Document number(s) of the earlier application(s) in
accordance with Art. 76 EPC:
00976168.5 / 1 232 323

(71) Applicant: **Weatherford/Lamb, Inc.**
Houston Texas 77027 (US)
Designated Contracting States:
NL

Remarks:

This application was filed on 27 - 07 - 2004 as a
divisional application to the application mentioned
under INID code 62.

(54) **Wrenching tong**

(57) Apparatus for applying torque to a first tubular relative to a second tubular, the apparatus comprising a first tong 1 for gripping the first tubular and a second tong 11 for gripping the second tubular, wherein the first tong is provided with teeth 14 around a peripheral sur-

face thereof, the second tong is provided with at least one pinion 7, and the pinion meshes with the teeth in such a way that the first tong and the second tong can be rotated relative to one another when the pinion is rotated.

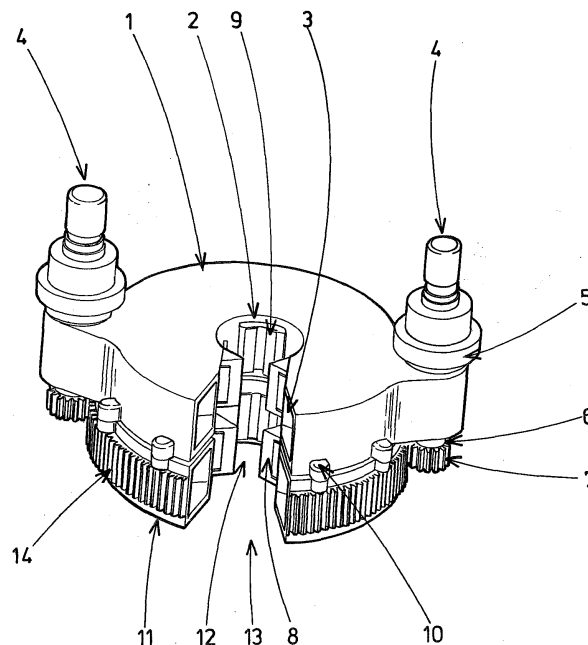

FIG 1

Description

[0001] This invention relates to wrenching tongs and other power tongs.

[0002] In the construction of oil or gas wells it is usually necessary to construct long drill pipes. Due to the length of these pipes, sections or stands of pipe are progressively added to the pipe as it is lowered into the well from a drilling platform. In particular, when it is desired to add a section or stand of pipe the string is usually restrained from falling into the well by applying the slips of a spider located in the floor of the drilling platform. The new section or stand of pipe is then moved from a rack to the well centre above the spider. The threaded pin of the section or stand of pipe to be connected is then located over the threaded box of the pipe in the well and the connection is made up by rotation therebetween. An elevator is connected to the top of the new section or stand and the whole pipe string lifted slightly to enable the slips of the spider to be released. The whole pipe string is then lowered until the top of the section is adjacent the spider whereupon the slips of the spider are re-applied, the elevator disconnected and the process repeated.

[0003] It is common practice to use a power tong to torque the connection up to a predetermined torque in order to make this connection. The power tong is located on the platform, either on rails, or hung from a derrick on a chain. In order to make up or break out a threaded connection, a two tong arrangement is necessary. An active (or wrenching) tong supplies torque to the section of pipe above the threaded connection, while a passive (or back up) tong supplies a reaction torque below the threaded connection. The back up tong clamps the pipe below the threaded connection, and prevents it from rotating. This clamping can be performed mechanically, hydraulically or pneumatically. The wrenching tong clamps the upper part of the connection and is driven so that it supplies torque for a limited angle.

[0004] This power tong arrangement is also used to torque up connections between other tubulars, for example casing and tubing.

[0005] Normally, in order to supply high torque, the wrenching tong is driven hydraulically. One or two hydraulic cylinders drive the tong through a small angle, typically in the region of 25°, depending on the tong design. Due to the geometric configuration normally used, the torque output of the tong changes as a sine function of the angle driven, which results in a reduction of torque output across the drive angle of up to 15%.

[0006] In order to make up or break out a connection of modern drill pipe or casing, high torque must be supplied over a large angle. This angle is sometimes six times higher than a conventional wrenching tong can supply. In order to overcome this, the wrenching tong must grip and wrench the tubular several times to tighten or break the threaded connection fully. This has a number of disadvantages. The action of gripping and re-

leasing the pipe repeatedly can damage the pipe surface. Due to the high costs associated with the construction of oil and gas wells, time is critical, and the repeated clamping and unclamping of the wrenching tong greatly increases the time taken to attach each new section or stand of tubulars. It also has the effect that the torque provided is discontinuous, increasing the difficulty of accurately controlling the torque with respect to the angle turned.

[0007] WO 93/18276 discloses an apparatus for applying torque to a first tubular relative to a second tubular. The apparatus comprises first and second tongs for gripping the first and second tubulars, respectively.

[0008] GB 2128526 discloses a tong for gripping a tubular, driven by a pinion and gear.

[0009] GB 1215967 discloses a tool secured in rotary table slips, and tongs for coupling and uncoupling tubulars.

[0010] According to a first aspect of the present invention there is provided apparatus for applying torque to a first tubular relative to a second tubular, the apparatus comprising a first tong for gripping the first tubular and a second tong for gripping the second tubular, wherein the first tong is provided with teeth around a peripheral surface thereof, the second tong is provided with at least one pinion, and the pinion meshes with the teeth in such a way that the first tong and the second tong can be rotated relative to one another when the pinion is rotated.

[0011] Preferably the first tong is a back-up tong and the second tong is a wrenching tong. Both tongs are preferably substantially cylindrical, and an axial passage is preferably provided therethrough for receiving tubulars. A passage is preferably provided from a peripheral edge to the axial passage of each tong to allow the introduction of tubulars into the axial passage. The pinion is preferably located at or near the periphery of the second tong. A motor may be provided on the second tong and coupled to the or each pinion.

[0012] The second tong is preferably provided with two pinions, although in another embodiment it may be provided with only one. The pinions are preferably located at or near the periphery of the second tong spaced by substantially 180° about the longitudinal axis of the tong. In another embodiment they may be spaced by substantially 120° about the longitudinal axis of the tong.

[0013] Preferably, the first tong comprises a plurality of hydraulically driven clamping jaws for gripping the first tubular and the second tong comprises a plurality of hydraulically driven clamping jaws for gripping the second tubular. Each jaw may be equipped with two or more dies, and is preferably attached to hydraulic driving means via a spherical bearing, although the jaw may be an integral part of the hydraulic driving means.

[0014] Bearings supported on resilient means are preferably provided between the first tong and the second tong to facilitate relative axial movement of the first and second tongs.

[0015] According to a second aspect of the present invention there is provided apparatus for applying torque to a first tubular relative to a second tubular, the apparatus comprising a gear and at least one pinion, and first clamping means for clamping the first tubular within the gear, the pinion being attached to second clamping means for clamping the second tubular, and the pinion meshing with the gear in such a way that the first clamping means and the second clamping means can be rotated relative to one another by rotating the pinion.

[0016] The first clamping means preferably comprise jaws mounted within the gear about an axial passage extending through the gear. The second clamping means preferably comprises jaws mounted within a clamping housing about an axial passage extending therethrough. A motor is preferably fixed to the clamping housing and coupled to the or each pinion.

[0017] According to a third aspect of the present invention there is provided a method of applying torque to a first tubular relative to a second tubular, the method comprising:

clamping the first tubular in a first tong; clamping the second tubular in a second tong; and rotating a pinion connected to the second tong and which meshes with teeth provided around a peripheral surface of the first tong so as to rotate the first tong relative to the second tong.

[0018] According to a fourth aspect of the present invention there is provided a method of coupling a tool to a length of tubular, the method comprising the steps of:

securing the tool in a basket;
lowering a tong arrangement having a rotary part and a stationary part, relative to the basket to engage respective locking members of the tong arrangement and the basket, thereby fixing the basket and the tool relative to the stationary part of the tong arrangement; and
rotating the length of tubular using the rotary part of the tong arrangement so as to couple the tool to the length of tubular.

[0019] This method may be used to couple a tool such as a drill bit, to a length of drill pipe. The coupling portion of the length of drill pipe may be brought into proximity with a corresponding coupling portion of the tool either before or after the lowering of the tong arrangement.

[0020] The length of drill string may be gripped by the rotary part of the tong arrangement either before or after the lowering of the tong arrangement. The length of drill string may be located proximate to the basket containing the tool either before or after the string is gripped by the rotary part of the tong arrangement.

[0021] By carrying out the steps of the above fourth aspect of the present invention in reverse (including ro-

tating the length of tubing in the opposite direction), a tool may be decoupled from a length of tubular.

[0022] According to a fifth aspect of the present invention there is provided apparatus for enabling a tool to be secured to a length of drill pipe, the apparatus comprising:

a basket arranged to securely retain the tool;
a tong arrangement having a rotary portion and a stationary portion, the rotary portion being arranged in use to grip and rotate the length of tubular; and
first locking means provided on the basket and second locking means provided on the stationary portion of the tong arrangement, the first and second locking means being engageable with one another to fix the basket relative to the stationary portion of the tong arrangement.

[0023] Preferably the first and second locking means are engageable and disengageable by means of linear movement of the tong arrangement relative to the basket.

[0024] Preferably, the basket is arranged to prevent rotation of the tool in the basket, wherein in use the rotary portion of the tong arrangement may be used to rotate the length of drill pipe to secure a screw connection between the length of drill pipe and the tool.

[0025] Preferably, one of the first and second locking means comprises one or more slots, and the other of the first and second locking means comprises one or more projecting members, the slots and the members being engageable and disengageable by relative linear movement of the tong arrangement and the basket.

[0026] According to a sixth aspect of the present invention there is provided a tong for use in clamping a length of tubular during the making up or breaking out of a connection, the tong comprising:

a body portion having a central opening therein for receiving a length of tubular; and
at least two clamping mechanisms mounted in said body, the clamping mechanisms being radially spaced about said opening;
a plurality of elongate mounting members disposed between each of the clamping mechanisms and the body of the tong, each mounting member having a flat face for abutting a side of a clamping mechanism and a rounded side for locating in a complementary shaped recess in the tong body,

wherein each tong may be displaced to some extent from radial alignment with the central opening of the tong.

[0027] Some preferred embodiments of the invention will now be described by way of example only and with reference to the accompanying drawings, in which:

Figure 1 is a view of an arrangement of a wrenching

tong and a back-up tong;

Figure 2 is a side view of the wrenching tong and back-up tong of Figure 1;

Figure 3 is a view of the back-up tong of Figure 1;

Figure 4 is a cutaway view of the back-up tong of Figure 1;

Figure 5 is a cutaway view of the wrenching tong of Figure 1;

Figure 6 is a view of the wrenching tong and back-up tong of Figure 1 supported by a C-frame and fixed in a frame for handling equipment on tracks at a rig floor;

Figure 7 is a view of the wrenching tong and back-up tong of Figure 1 in use, with a tubular clamped in the wrenching tong;

Figure 8 is a view of an arrangement of an alternative wrenching tong and back-up tong;

Figure 9 is a view of an arrangement of a further alternative wrenching tong and back-up tong;

Figure 10 illustrates a modified tong arrangement;

Figure 11 illustrates a modified back-up tong;

Figure 12 illustrates in detail a clamping arrangement of the tong of Figure 11 including support elements;

Figure 13 illustrates an arrangement for connecting a drill bit to a length of drill pipe;

Figure 14 illustrates the arrangement of Figure 13 during the connection operation; and

Figure 15 illustrates the arrangement of Figure 13 following completion of the connection operation.

[0028] Figures 1 and 2 show an arrangement of a composite wrenching tong and back-up tong. A wrenching tong 1 is generally in the form of a disc with an opening 2 through the centre thereof for receiving a stand of drill pipe (not shown), and a recess 3 cut from the edge to the opening 2 at the centre. The wrenching tong 1 is provided with two pinion drives 4 arranged opposite each other at the periphery of the disc, equally spaced either side of the recess 3. Each pinion drive comprises a drive motor 5, drive shaft 6, and pinion 7 attached to the drive shaft 6.

[0029] A back-up tong 11 is located beneath the wrenching tong 1. The back-up tong is generally in the

form of a disc with similar dimensions to the wrenching tong 1. The back-up tong is also provided with an opening 12 through the centre and a recess 13 from the edge to the opening at the centre. The opening 12 and recess 13 correspond to the opening 2 and recess 3 of the wrenching tong when the back-up tong 11 and the wrenching tong 1 are correctly aligned.

[0030] A plurality of guide rollers 10 or other guide elements are spaced around the edge of the wrenching tong 1 in order to maintain the alignment of the wrenching tong 1 with the back-up tong 11.

[0031] A gear 14 is provided around the periphery of the back-up tong 11, broken by the recess 13. The gear 14 meshes with the pinions 7 attached to the motors 5 on the wrenching tong, so that when the drive motors 5 drive the drive shafts 6 and gears 7, the wrenching tong 1 rotates relative to the back-up tong 11. The angle of rotation is limited by the recess 13 of the back up tong.

[0032] Figure 3 shows a back-up tong 11 before the wrenching tong is placed on top of it. The back-up tong 11 has a plurality of roller bearings 21, upon which the wrenching tong 1 is designed to be placed. The roller bearings 21 are supported by resilient means such as springs, elastic material or hydraulic/pneumatic cylinders, in order to support the wrenching tong during wrenching. During one wrenching cycle, the stands will move axially relative to one another as the connection is tightened. The wrenching tong must follow the axial movement of the top stand during one wrenching cycle. This axial travel length depends on the pitch of the thread.

[0033] Three clamping jaws 8 equipped with dies 9 are located inside each of the wrenching tong 1 and back-up tong 11. These are hydraulically driven for clamping the drill pipe stand in place in the centre of the wrenching tong. The hydraulic power supply may be provided by hoses (not shown).

[0034] Figure 4 shows the clamping mechanism of the back-up tong 11. Three hydraulic pistons 16, comprising piston rods 17 and chambers 18, are located inside the casing of the back-up tong 11. Each piston rod 17 has an end 19 which is secured to the outside edge of the back-up tong 11. At the other end of the piston, the jaw 8 containing two dies 9 with teeth (not shown) is fixed to the chamber 18 by a spherical bearing 20. With the arrangement shown, each drill pipe stand is clamped by three jaws and six dies at the joint. The spherical bearings 20 enable the jaws and dies to match the pipe surfaces closely, resulting in a low penetration depth of the teeth of the dies into the pipe surface, and thus prolonging the life of the drill pipe. The wrenching tong has a similar clamping jaw design, as shown in Figure 5.

[0035] Figure 6 shows the wrenching tong 1 and back-up tong 11 supported by a C-frame 22 for handling at the rig. The C-frame 22 is in turn fixed in a frame 23 for handling the equipment on tracks at the rig floor. A drill pipe spinner 24 is mounted on the C-frame above the tongs for rotating a drill pipe stand at high speed.

[0036] In order to make a connection between two stands of drill pipe, the recesses 3 and 13 in the wrenching 1 and back-up 11 tongs are aligned (the tongs may already be in this configuration following the removal of the tongs from a previous section of tubing). Two stands of drill pipe 25,26 are then introduced into the openings 2,12 in the wrenching and back-up tongs 1,11, respectively, through the recesses 3,13, and the lower stand 26 is clamped in position in the back-up tong 11. The upper stand 25 is introduced into the drill pipe spinner 24, and rotated at high speed in order to pretighten the threaded connection. The final high torque will be applied by the wrenching tong 1.

[0037] The upper stand 25 is now clamped in position in the opening 2 through the wrenching tong 1. The pinion drives 4 are then driven to torque the connection between the stands 25,26 until the connection is fully tightened or until one of the pinion drives 4 is at the edge of the recess 13, at which stage the wrenching tong 1 is at one end of its possible arc of travel relative to the back-up tong 11. The maximum wrenching angle which can be reached in one cycle in the embodiment shown is +/- 75°. If necessary, the upper stand 25 can then be released from the wrenching tong 1, the tong returned to its original position, and the torquing process repeated.

[0038] To break a connection, the above operation is reversed.

[0039] An even larger wrenching angle can also be simply achieved with this arrangement, as shown in Figure 7. The stands of drill pipe 25,26 are introduced to the tongs 1,11 through the recesses 3,13 and pretightened using the drill pipe spinner 24 as described above. However, before the top stand 25 is clamped in place in the opening 2, the wrenching tong drive is reversed, and the wrenching tong 1 is driven to its end position relative to the back-up tong, as shown in Figure 7. The top stand 25 is now clamped with the tongs in this position, so that with the embodiment shown a wrenching angle of 150° is achievable.

[0040] Figure 8 shows a similar arrangement of a composite wrenching tong and back-up tong to that described above. However, in this case only one pinion drive 4 is used, which increases the possible wrenching angle to 300°.

[0041] Figure 9 shows another similar arrangement, with two pinion drives 4 being used as in Figures 1 to 7. This time the pinion drives 4 are not opposite each other, but spaced 120° each side of the recess 3. This gives the advantage of the torque and control provided by two drives, but allows a higher wrenching angle than the arrangement of Figure 1. The maximum wrenching angle in this embodiment will be in the region of 210°.

[0042] The torque can be monitored by measuring the reaction torque at each drive by means of a load cell, or by measuring the pressure of the drive motor.

[0043] It is to be understood that other variations are possible while still falling within the scope of the invention. For example, the preferred embodiments show an

arrangement whereby the pinion drives are mounted on the wrenching tong and the gear is mounted on the back-up tong. However, the arrangement could be the other way round with the pinion drives mounted to the back-up tong and the large gear mounted on the wrenching tong. Such an arrangement is illustrated in Figure 10.

[0044] Alternatively, the wrenching tong could be provided with a gear, and the pinion drives mounted on the frame 24.

[0045] Hydraulic clamping cylinders are shown, but the tong could clamp the drill pipe stands by any known means.

[0046] The preferred embodiments show one or two pinion drives, but more could be used if arranged in a suitable configuration.

[0047] Although the preferred embodiments have been described in relation to tightening stands of drill pipe, it is to be understood that the arrangements described are suitable for applying torque to any tubular sections.

[0048] Figure 11 illustrates in partial section a modified back-up tong 40 which may replace the back-up tong 11 of the embodiment of Figure 1 to 9. The modified tong 40 has only two jaws 41 associated with respective clamping arrangements 42. Each arrangement 42 is held in place within the main body 43 of the tong 40 by a set of four "pendulum" bolts 44. A clamping arrangement 42 associated with four pendulum bolts 44 is illustrated in more detail in Figure 12 from which it can be seen that each bolt comprises a cylinder cut in half along its longitudinal axis to provide a flat surface and a rounded surface. The flat surface of each bolt 44 abuts the side of the clamping arrangement 42, whilst the rounded side is located in a rounded recess 45 provided in the side of the main body 43 opposed to the clamping arrangement. It will be appreciated that as the bolts 44 are able to rotate within their respective recesses in the tong body 43, each clamping arrangement 42 may pivot slightly about its centre. This allows the jaws 41 to conform to the outer surface of a tubular to be clamped when the tubular is for example not perfectly cylindrical.

[0049] Figure 13 illustrates apparatus which can be used in association with a tong arrangement 49 to connect and disconnect a tool such as a drill bit to and from a length of tubular such as a drill pipe. The apparatus comprises a basket 50 which is arranged in use to be placed on the floor of a drilling rig. The basket 50 has an opening in the top thereof for receiving a tool 51 which is to be connected to a length of tubular 52. The opening has a shape which is complimentary to the shape of the tool 51 such that the tool is held securely in an upright position and rotation of the tool within the basket 50 is prevented.

[0050] Two opposed sides of an upper plate of the basket 50 are provided with slots 53. These slots 53 are shaped to receive locking members 54 which project downwardly from the lower surface of the back-up tong

55 of the tong arrangement. The operation to connect a tool will now be described.

[0051] As shown in Figure 13, the tool 51 is first located in the basket 50. The length of tubular 52 is moved to a position over the tool (Figure 14) and is lowered to bring the box of the tubular into engagement with the externally threaded coupling of the tool 51. At this point, the tong arrangement is brought up to the tubular 52 with the jaws of the rotary and back-up tongs being fully opened, and the tong is placed around the tubular 52. The tong arrangement is then lowered within its frame, to a position in which the locking members 54 are received by the respective receiving slots 53 of the basket 50. In this position, the basket is locked to the back-up tong. The jaws of the rotary tong are then clamped against the tubular 52 and the rotary tong rotated, relative to the back-up tong, to tighten the threaded joint (Figure 15). The jaws of the rotary tong are then released, and the tong arrangement withdrawn from around the tubular. The tubular and the connected tool can then be lifted clear of the basket 50.

[0052] It will be appreciated that the tool 51 may be disconnected from the tubular 52 by carrying out the same operation but in reverse.

Claims

1. Apparatus for applying torque to a first tubular relative to a second tubular, the apparatus comprising a first tong for gripping the first tubular and a second tong for gripping the second tubular, **characterised in that** the first tong is provided with teeth around a peripheral surface thereof, the second tong is provided with at least one pinion, and the pinion meshes with the teeth in such a way that the first tong and the second tong can be rotated relative to one another when the pinion is rotated.
2. Apparatus as claimed in claim 1, wherein the first tong is a back-up tong and the second tong is a wrenching tong.
3. Apparatus as claimed in claim 1 or 2, wherein the or each pinion is located at or near the periphery of the second tong.
4. Apparatus as claimed in claim 1, 2 or 3, wherein the first tong is substantially cylindrical.
5. Apparatus as claimed in any preceding claim, wherein the second tong is substantially cylindrical.
6. Apparatus as claimed in any preceding claim, wherein each of the first and second tongs have an axial passage extending therethrough for receiving a tubular.
7. Apparatus as claimed in claim 6, wherein a passage is provided from the edge to the axial passage of each of the first and second tongs to allow the introduction of a tubular into the axial passage of each of the first and second tongs.
8. Apparatus as claimed in any preceding claim, wherein a motor is provided on the second tong and coupled to the or each pinion.
9. Apparatus as claimed in any preceding claim, wherein the second tong is provided with two pinions.
10. Apparatus as claimed in claim 9, wherein the pinions are located at or near the periphery of the second tong spaced by substantially 180° about the longitudinal axis of the tong.
11. Apparatus as claimed in claim 9, wherein the pinions are located at or near the periphery of the second tong spaced by substantially 120° about the longitudinal axis of the tong.
12. Apparatus as claimed in any of claims 1 to 8, wherein the second tong is provided with only one pinion.
13. Apparatus as claimed in any preceding claim, wherein the first tong comprises a plurality of hydraulically driven clamping jaws for gripping the first tubular.
14. Apparatus as claimed in any preceding claim, wherein the second tong comprises a plurality of hydraulically driven clamping jaws for gripping the second tubular.
15. Apparatus as claimed in claim 13 or 14, wherein each jaw is equipped with two or more dies.
16. Apparatus as claimed in claim 13, 14 or 15, wherein each jaw is attached to hydraulic driving means via a spherical bearing.
17. Apparatus as claimed in claim 13, 14 or 15, wherein the first tong and second tong each comprise a plurality of hydraulic driving means, each hydraulic driving means comprising a piston rod and a piston chamber, and the jaw is an integral part of the hydraulic driving means, the dies being placed in pockets in the piston chamber.
18. Apparatus as claimed in any preceding claim, wherein bearings supported on resilient means are provided between the first tong and the second tong to support one tong on top of the other tong.
19. Apparatus for applying torque to a first tubular rel-

ative to a second tubular, the apparatus comprising a gear and at least one pinion, and first clamping means for clamping the first tubular within the gear, **characterised in that** the pinion is attached to second clamping means for clamping the second tubular, and **in that** the pinion meshes with the gear in such a way that the first clamping means and the second clamping means can be rotated relative to one another by rotating the pinion.

5

10

20. Apparatus as claimed in claim 19, wherein the first clamping means comprises jaws mounted within the gear about an axial passage extending through the gear.

15

21. Apparatus as claimed in claim 19 or 20, wherein the second clamping means comprises jaws mounted within a clamping housing about an axial passage extending therethrough..

20

22. Apparatus as claimed in claim 21, further comprising a motor fixed to the clamping housing and coupled to the or each pinion.

23. Apparatus as claimed in any preceding claim for assembling downhole tubing.

25

24. A method of applying torque to a first tubular relative to a second tubular, the method comprising:

30

clamping the first tubular in a first tong; and
clamping the second tubular in a second tong;

characterised by rotating a pinion connected to the second tong and which meshes with teeth provided around a peripheral surface of the first tong so as to rotate the first tong relative to the second tong.

35

40

45

50

55

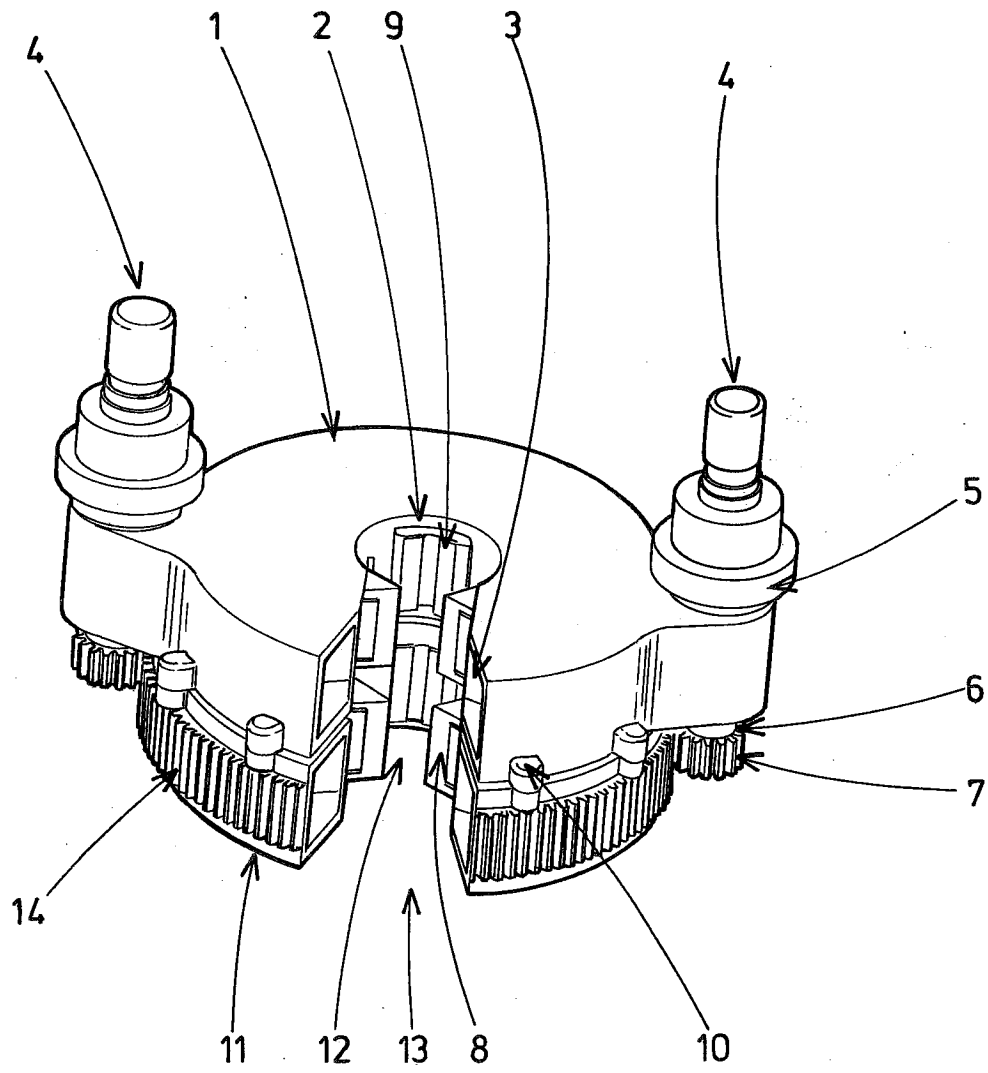

FIG 1

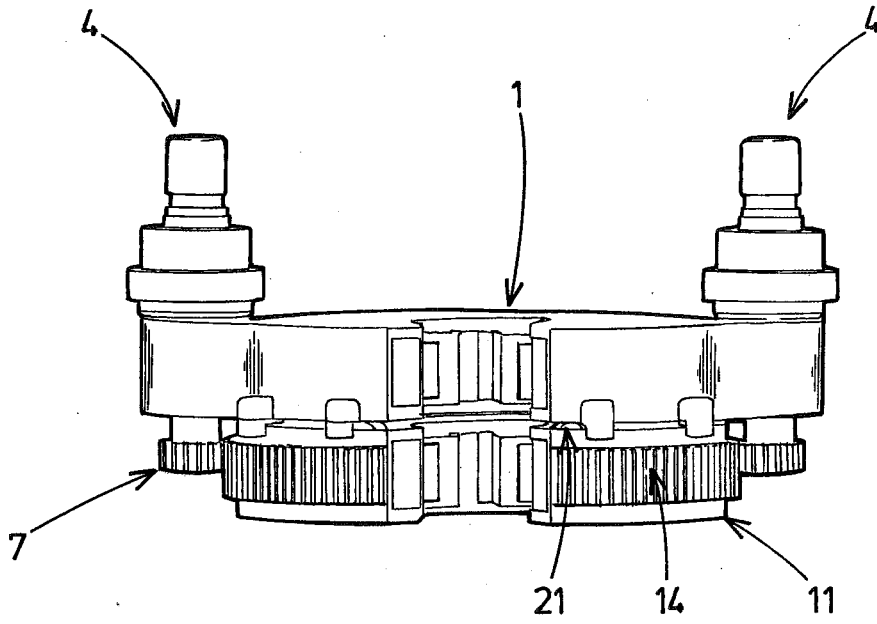

FIG 2

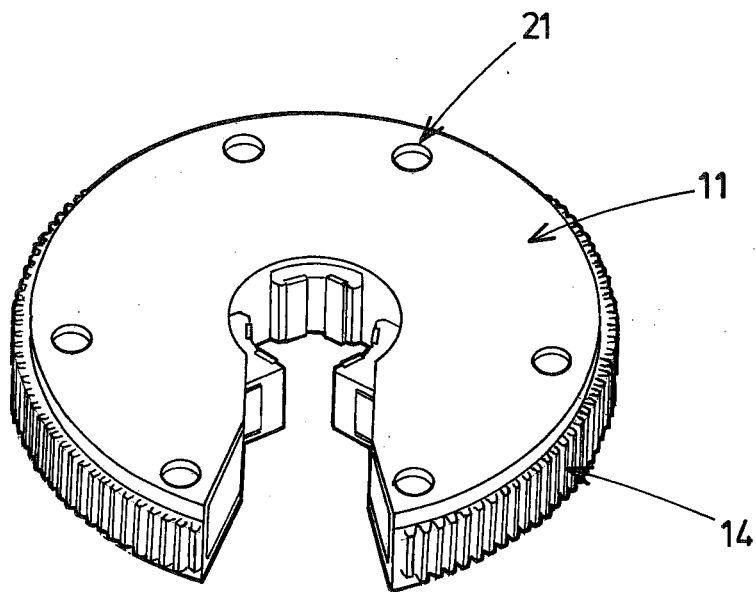

FIG 3

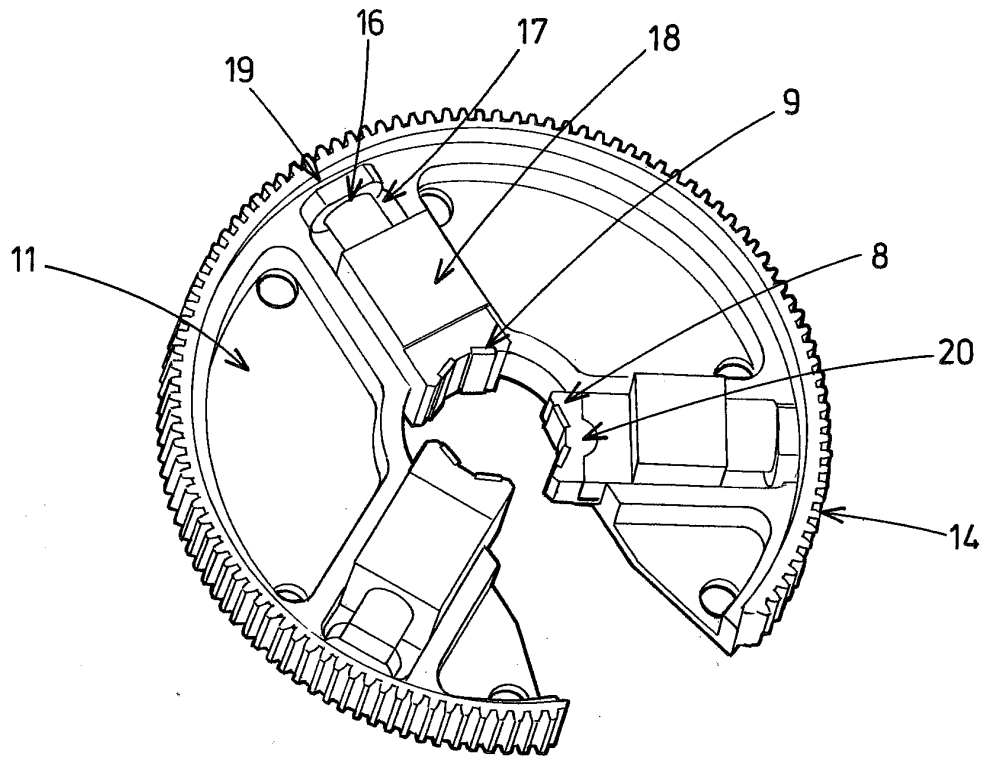

FIG 4

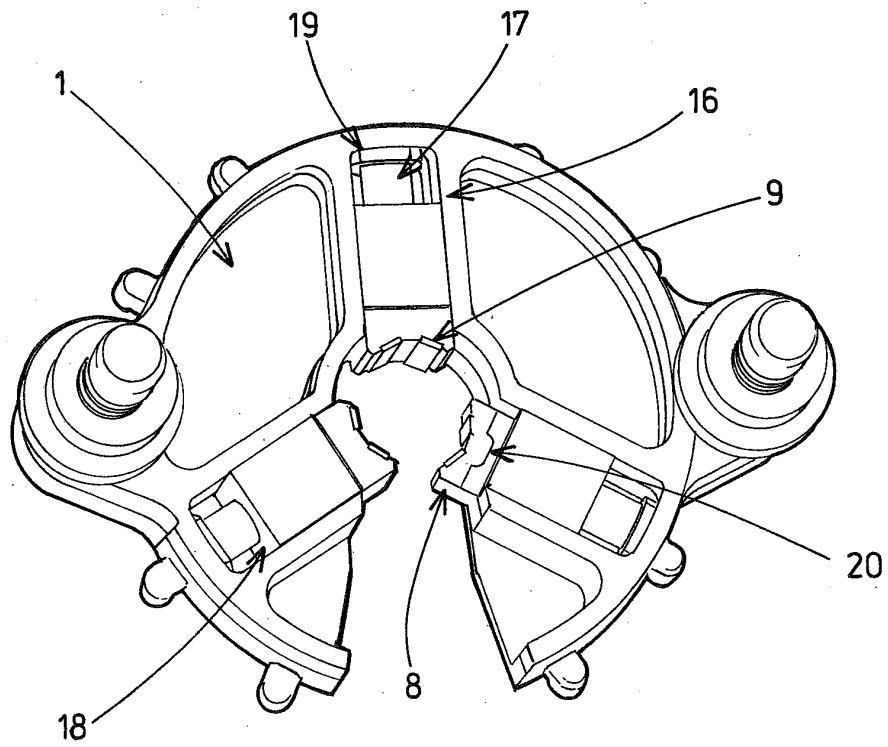

FIG 5

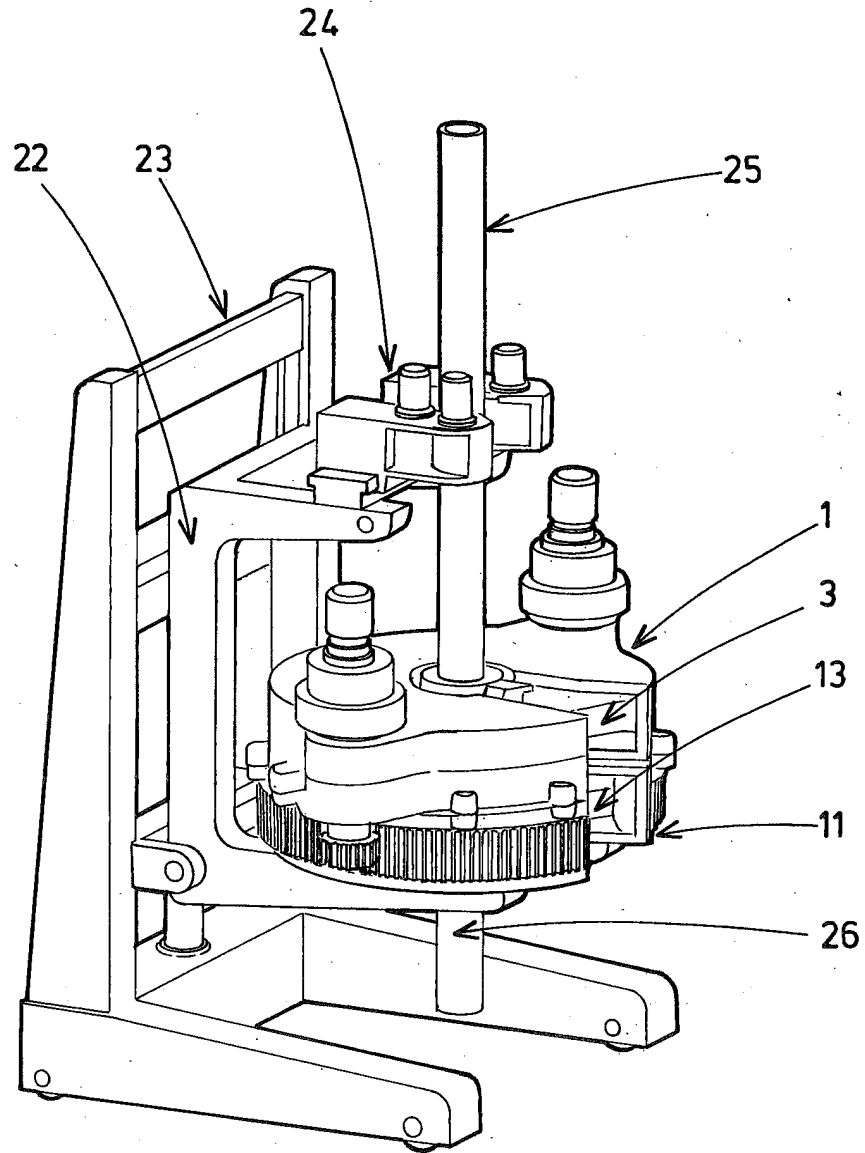

FIG 6

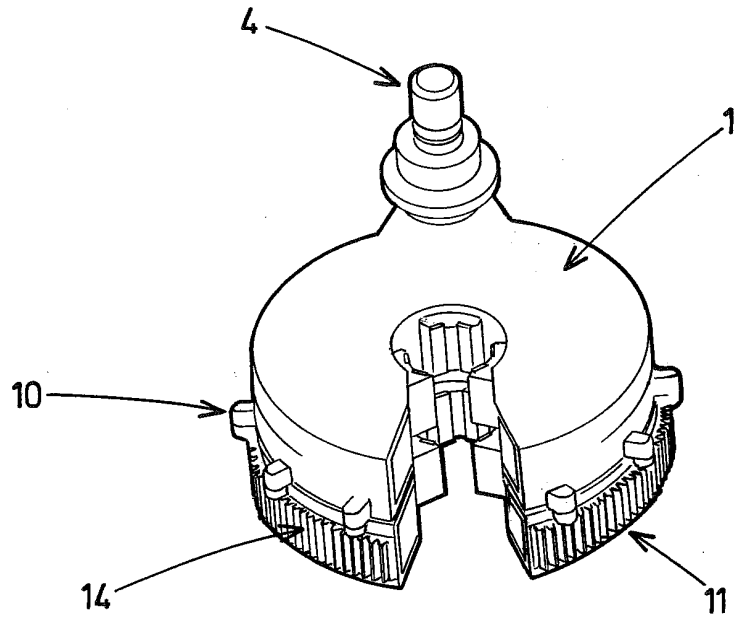

FIG 8

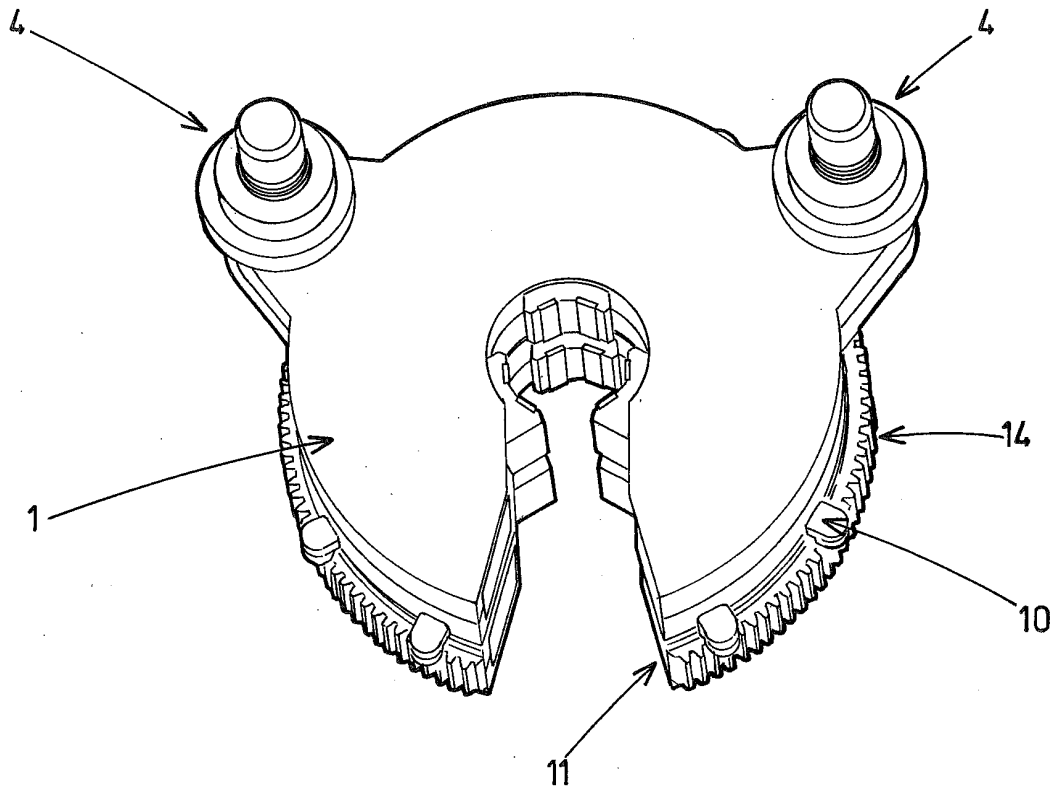

FIG 9

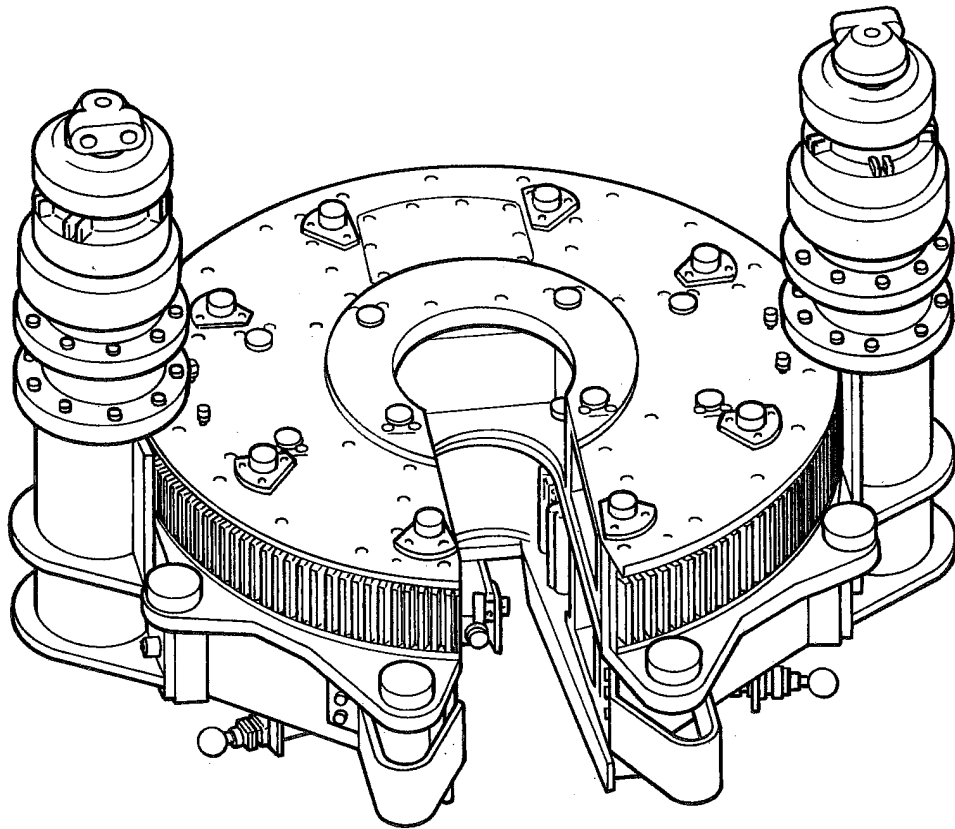

FIG 10

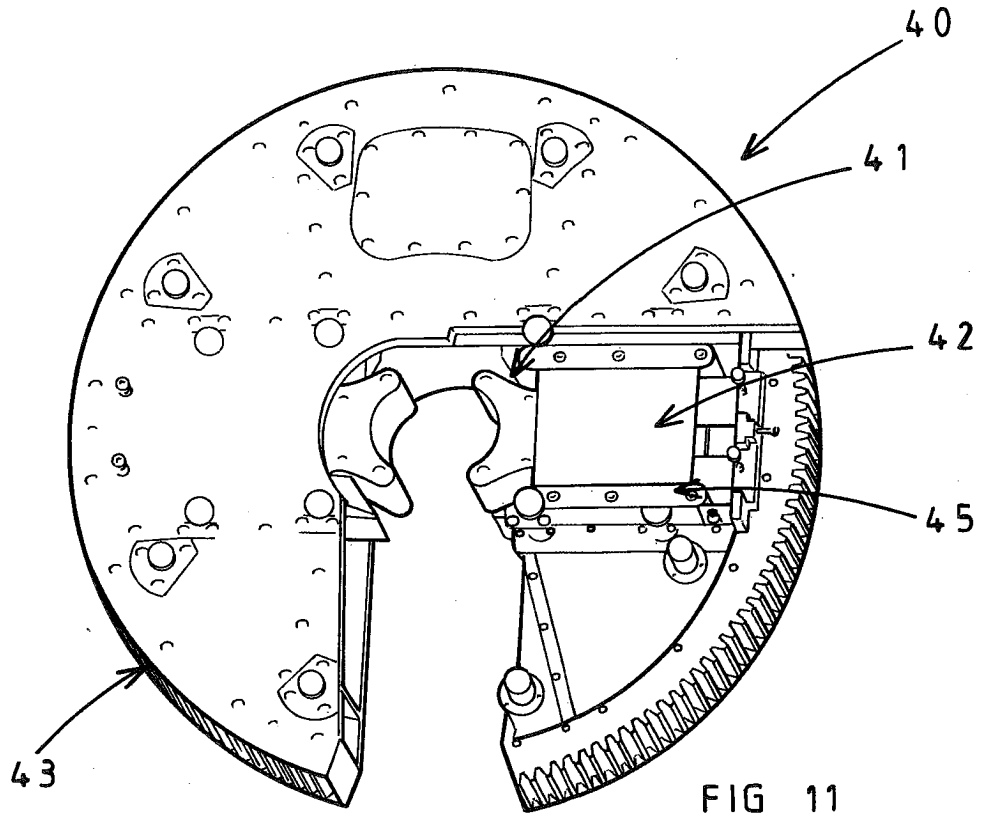

FIG 11

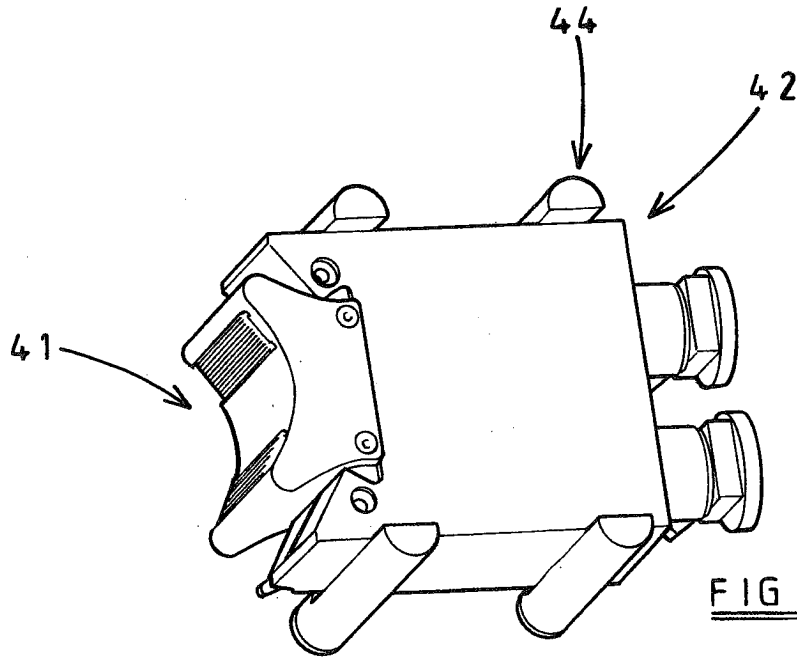

FIG 12

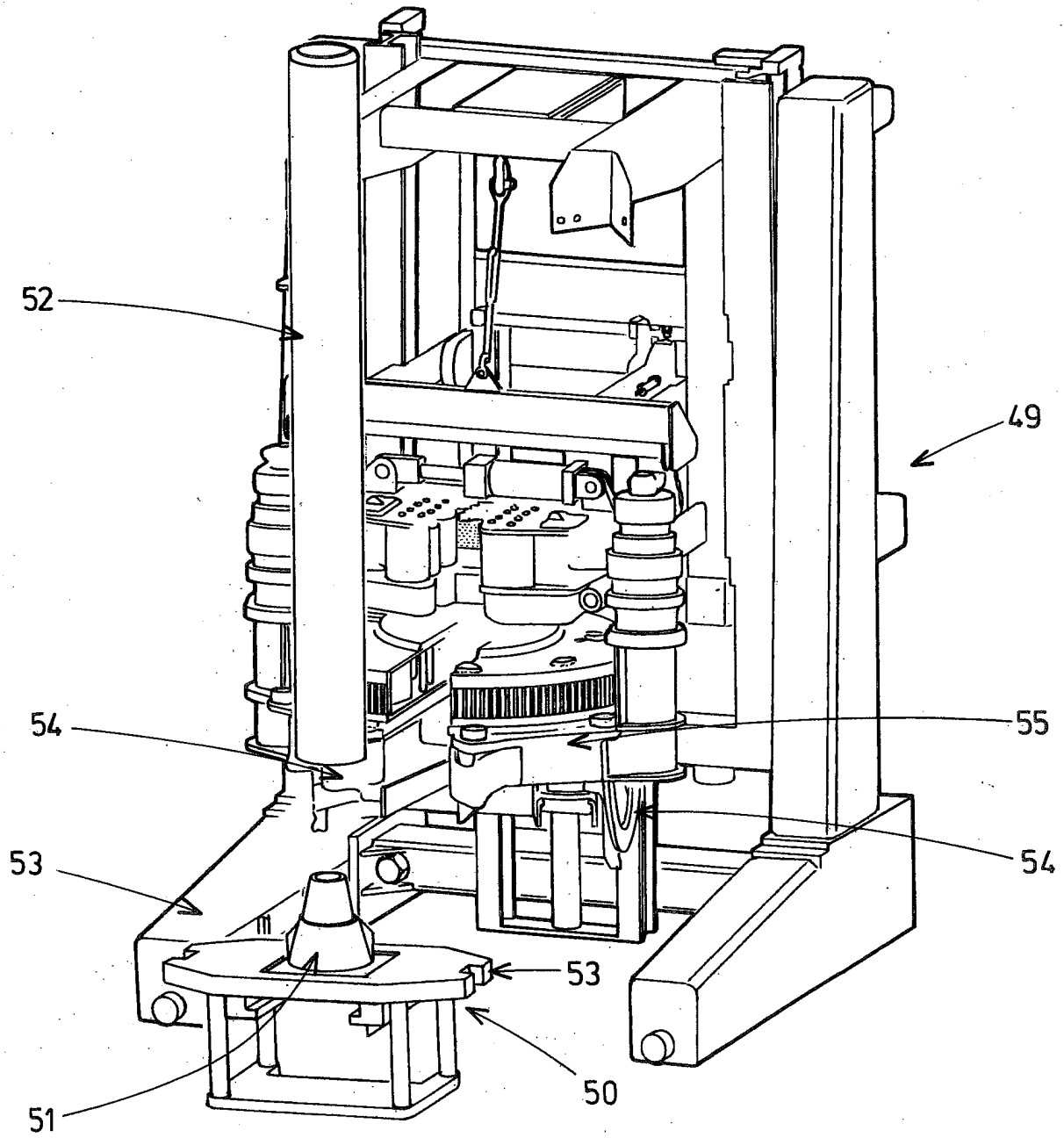

FIG 13

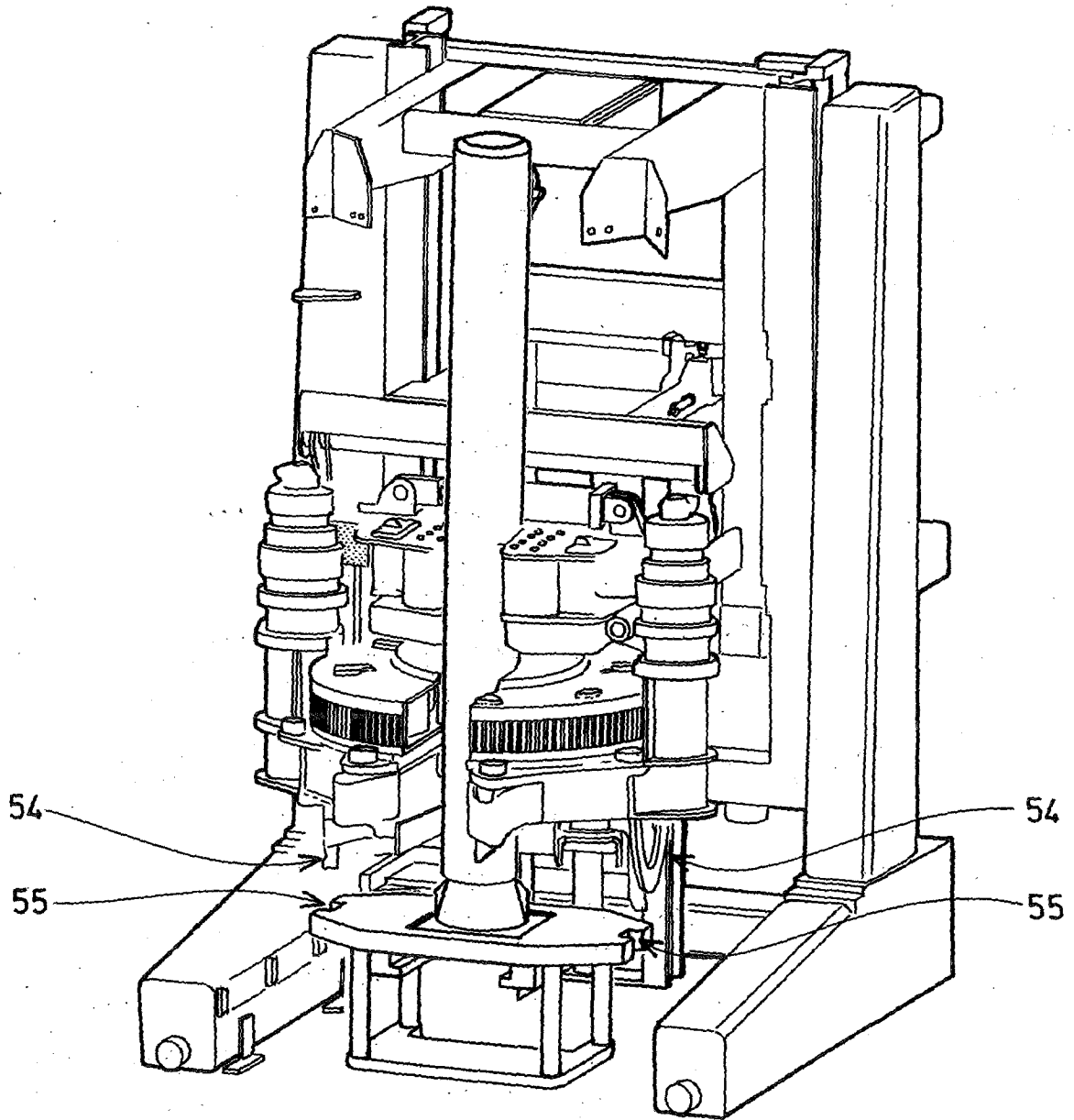

FIG 14

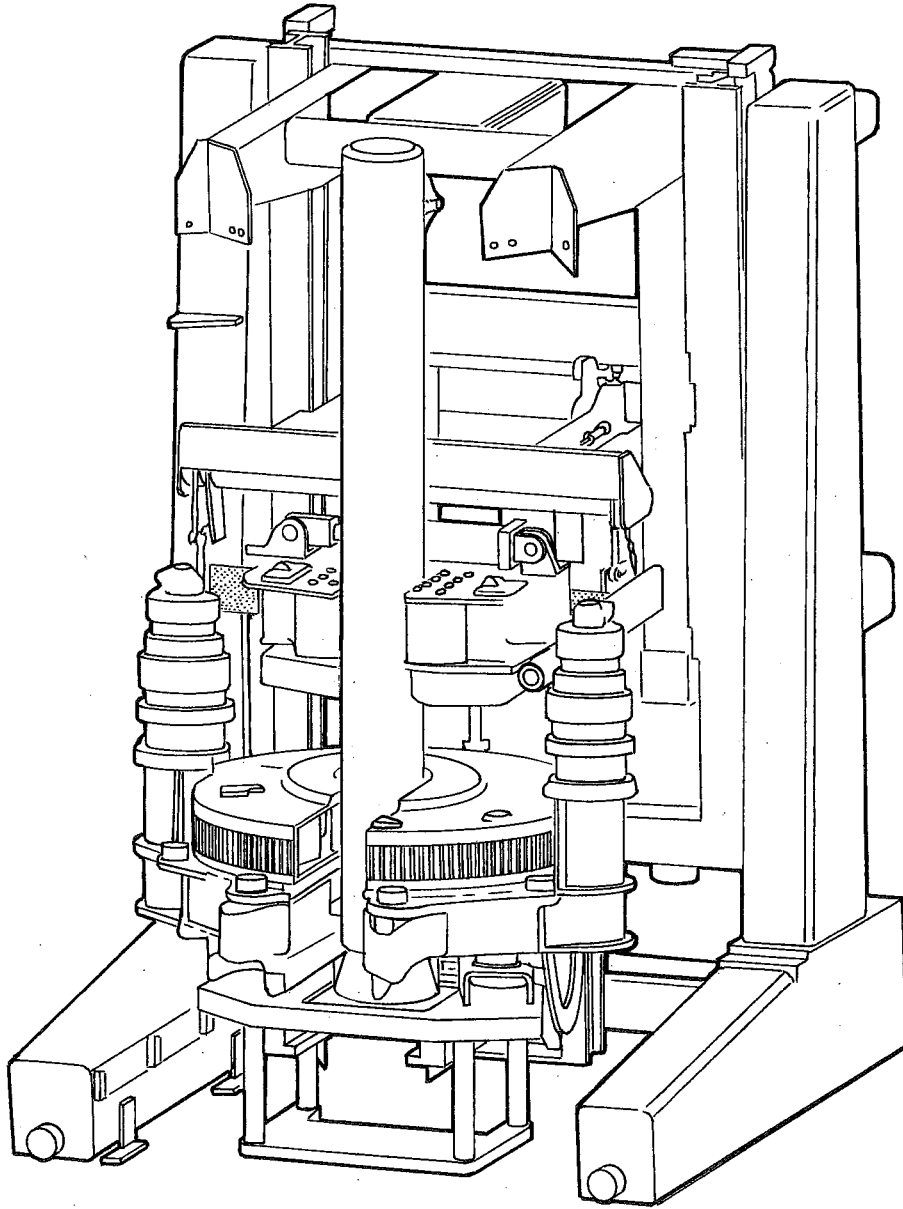

FIG 15



European Patent
Office

EUROPEAN SEARCH REPORT

Application Number
EP 04 10 3600

DOCUMENTS CONSIDERED TO BE RELEVANT			
Category	Citation of document with indication, where appropriate, of relevant passages	Relevant to claim	CLASSIFICATION OF THE APPLICATION (Int.Cl.7)
A	GB 2 128 526 A (CHRISTENSEN INC) 2 May 1984 (1984-05-02) * page 2, line 28 - line 40 * -----	1,19,24	E21B19/16
A	US 5 092 399 A (LANG DUANE) 3 March 1992 (1992-03-03) * column 6, line 18 - line 49 * -----	1,19,24	
A	US 4 442 892 A (DELESANDRI DOMENICO) 17 April 1984 (1984-04-17) * column 5, line 28 - line 45 * -----	1,19,24	
A	WO 93/18276 A (WEATHERFORD LAMB ;LUCAS BRIAN RONALD (GB)) 16 September 1993 (1993-09-16) * page 3, line 26 - page 4, line 21 * * page 6, line 35 - page 7, line 1 * -----	1,19,24	
			TECHNICAL FIELDS SEARCHED (Int.Cl.7)
			E21B
The present search report has been drawn up for all claims			
Place of search		Date of completion of the search	Examiner
The Hague		14 September 2004	Garrido Garcia, M
CATEGORY OF CITED DOCUMENTS			
X : particularly relevant if taken alone Y : particularly relevant if combined with another document of the same category A : technological background O : non-written disclosure P : intermediate document T : theory or principle underlying the invention E : earlier patent document, but published on, or after the filing date D : document cited in the application L : document cited for other reasons ----- & : member of the same patent family, corresponding document			

EPO FORM 1503 03 82 (P04C01)

**ANNEX TO THE EUROPEAN SEARCH REPORT
ON EUROPEAN PATENT APPLICATION NO.**

EP 04 10 3600

This annex lists the patent family members relating to the patent documents cited in the above-mentioned European search report. The members are as contained in the European Patent Office EDP file on The European Patent Office is in no way liable for these particulars which are merely given for the purpose of information.

14-09-2004

Patent document cited in search report		Publication date	Patent family member(s)	Publication date
GB 2128526	A	02-05-1984	DE 3234027 C1	19-01-1984
US 5092399	A	03-03-1992	NONE	
US 4442892	A	17-04-1984	NONE	
WO 9318276	A	16-09-1993	CA 2131537 A1	16-09-1993
			WO 9318276 A1	16-09-1993
			EP 0629260 A1	21-12-1994
			NO 943255 A	02-09-1994
			US 5390568 A	21-02-1995