



(12) **EUROPEAN PATENT APPLICATION**

(43) Date of publication:
17.11.2004 Bulletin 2004/47

(51) Int Cl.7: **F24B 1/06**

(21) Application number: **04396035.0**

(22) Date of filing: **14.05.2004**

(84) Designated Contracting States:
**AT BE BG CH CY CZ DE DK EE ES FI FR GB GR
HU IE IT LI LU MC NL PL PT RO SE SI SK TR**
Designated Extension States:
AL HR LT LV MK

(72) Inventor: **Mikko, Tuovinen**
83900 Juuka (FI)

(74) Representative: **Helino, Timo et al**
Papula Oy,
P.O. Box 981
00101 Helsinki (FI)

(30) Priority: **15.05.2003 FI 20030731**

(71) Applicant: **Nunnanlahden Uuni Oy**
83940 Nunnanlahti (FI)

(54) **Joint in a fireplace**

(57) A joint in a fireplace for joining a stone part (1) and a structural part (2) made of other material with one another, the stone part including a first planar surface (3), against which the structural part is fastened, and a second planar surface (4), which is at an angle against the first planar surface and which includes a groove (5) extending away from the structural part and being formed by the edges and the bottom, the joint including an elongated locking part (6). According to the invention,

the first end of the locking part (6) includes a coupling element (7) and the structural part (2) includes a counterpart (8) of the coupling element for rigidly locking the locking part and the structural part in the longitudinal direction of the locking part. In addition, substantially the second end of the locking part includes at least one edge tightening element (9) for implementing the longitudinal tightening fastening of the locking part in the edge of the groove.

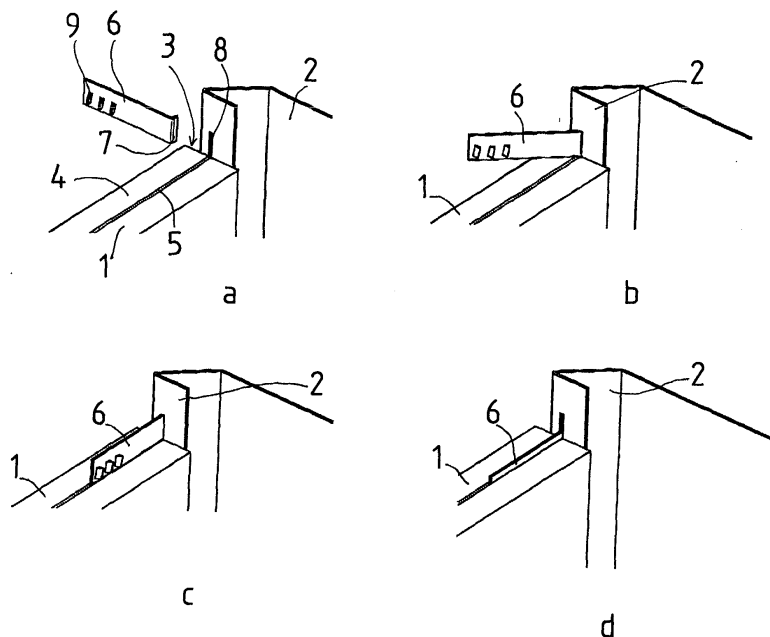

Fig 1

Description

[0001] The invention relates to a joint to be used in a fireplace as defined in the preamble of claim 1 for joining a stone part and a structural part made of other material with one another.

[0002] The closest prior art in the field of the invention represent Finnish patents FI 87687, FI 87688, FI 87689, FI 88070 and FI 89304. All these patent publications disclose different angle structures of fireplaces in which two cornerwise placed stone parts are joined with each other from the corner using a suitably shaped metal profile, which is fixed to the stone element using various hooks or the like. The fixing of the hooks in the stone element has been performed first in a longitudinal groove and at the end in a vertical boring. The fixing of the metal profile has been implemented in many different flexible and locking manners.

[0003] Common to all the prior-art structures, besides the longitudinal groove, is the need for a transverse boring and a rigid locking into the stone. In addition, all the tightening, pressing and locking are implemented at the end of the hook that is situated on the side of the metal profile.

[0004] Several problems are associated with the prior art. Longitudinal grooves and transverse borings or grooves have to be machined in the stone, which makes the machining of the stone both slow and costly. Most of the prior-art hooks consist of two or more parts, making their manufacturing costs high. Similarly, the use, mounting in place and tightening of hooks consisting of more than one part is slow, thus incurring additional costs.

[0005] Known in the field are also various locking hooks and locking strips which are designed for fixing two adjacent stone elements directly to each other. As an example of these we mention FI 96347 in which a sheet-like hook is fixed to one longitudinal and two transverse grooves; FI 83559 in which a sheet-like, curved hook, provided with end pegs, is inserted into a longitudinal groove and two borings; as well as FI 101491 in which an elongated, sheet-like metal strip provided with gripping projections is inserted into an elongated groove so that the metal strip engages the edges of the groove. All these are functional structures per se, but only applicable to the joining of two stone elements, and particularly soapstone elements, straight and directly with each other.

[0006] Lately, as the structures and structural materials of fireplaces made mainly of stone diversify and as the use of stone becomes common also in conjunction with conventional metallic stoves, there is a need to develop tight joint structures that are very heat-resistant, that enable the joining of stone and a structural part made of other material, such as metal, with one another, sufficiently firmly and fixedly.

[0007] The objective of the invention is to eliminate the drawbacks referred to above. One specific objective

of the invention is to disclose a new type of joint to be used in fireplaces between a stone part and a structural part made of other material, which enables a faster and more cost-efficient making of the joint and which makes the joint tighter and firmer, enabling the use of more simple and thus more advantageous joint parts and minimising the machining of the stone parts to be handled.

[0008] As for the features characteristic of the invention, reference is made to them in the claims.

[0009] The invention relates to a joint in a fireplace for joining a stone part and a structural part made of other material with one another. The other material usually consists of metal, cast iron or steel, but also e.g. various ceramic materials, tiles and other burned clays as well as various fire-resistant masses are possible. The stone part to be used in a fireplace includes a first planar surface against which the structural part is joined, and a second planar surface which is at an angle against the first planar surface. The second planar surface includes a groove extending away from the structural part and being formed by the edges and the bottom. The joint between the stone part and structural part includes an elongated locking part.

[0010] The first planar surface and the second planar surface of the stone part preferably are perpendicular to each other, and preferably the planar surfaces have a common sharp edge, from which they extend into different directions at an angle of 90 degrees with respect to each other. Thus, for example, as the stone part functions a stone part in the shape of a rectangular parallelepiped.

[0011] According to the invention, the first end of the elongated locking part includes a coupling element and the structural part includes a counterpart of the coupling element for locking the locking part and the structural part rigidly with respect to one another in the longitudinal direction of the locking part. In this manner, the coupling element and the counterpart lock the locking part into the structural part in the longitudinal direction of the locking part inflexibly rigidly and non-yieldingly. Furthermore, according to the invention, substantially the one end of the locking part includes at least one edge tightening element for implementing the longitudinal tightening fastening of the locking part in the edge of the groove.

[0012] In one embodiment of the invention, the coupling element consists of a rigid fold of the locking part, preferably a fold of 90 degrees in the elongated locking part. When the counterpart of the structural part made of other material is correctly shaped to correspond to a straight fold, i.e. it has a suitable sharp edge behind which the straight fold can be supported, a firm and rigid coupling between the joint part and the structural part can be easily implemented.

[0013] In another embodiment of the invention, the coupling element consists of a rigid hook, groove or notch, i.e. a suitable shape deviating from straight and uniform and enabling a sufficient gripping between the

joint part and the structural part.

[0014] In one embodiment of the invention, the counterpart of the coupling element consists of a hole, opening, projection or shoulder in the structural part to which the coupling element can be coupled.

[0015] In a preferred embodiment of the invention, the locking part includes at least two opposite edge tightening elements for implementing the tightening fastening in both edges of the groove. It is also possible that there are several edge tightening elements on opposite sides of the locking part so that the fastening, tightening and locking of the locking part, and through it that of the structural part, can be implemented along a long stretch in both edges of the groove. It must also be noted that, depending on the locking part, it is possible to use in the invention even a rather low groove, and this groove can always be equal in depth, i.e. the bottom of the groove can be a straight one because the locking and fastening are performed by pressing into the edges of the grooves and not into the borings made on the bottom of the groove, as in the prior-art technique.

[0016] Advantageously, the edge tightening element consists of a projection, protuberance, edge or peg, which as being partly supported on the groove edge, implements the tightening fastening. It is possible to use any sharp edges known per se that are perpendicular or at a slight oblique angle with respect to the groove to be locked for implementing a suitable locking and tightening. Also variously shaped projections and protuberances may have particular shapes, or figures or series implementing the desired locking and tightening functions may have been formed of them.

[0017] In one embodiment of the invention, the locking part consists of a metal strip such as e.g. a flat iron, whose first end has been shaped to form the desired coupling element and which has at its second end, or at least farther from the first end, one or more edge tightening elements.

[0018] In another embodiment of the invention, the locking part consists of a metal bar such as a sufficiently thick and rigid metal wire.

[0019] While the groove in the second planar surface can be curved or complicated, it preferably is a straight groove which is easy and simple to machine. Similarly, the straight groove preferably is at a right angle, i.e. perpendicular to the second planar surface, although an oblique groove is not an excluded embodiment of the invention.

[0020] The joint to be used in fireplaces as defined in the invention has considerable advantages over prior art. The joints between the stone part of the fireplace and structural parts made of other material can be made tight and firm. The joints are easy and simple to make. The locking parts to be used are simple and advantageous, and mounting them is fast with no need for specific tools, just by hammering. Apart from the one longitudinal groove, no other grooves or borings need to be machined in the stone parts as this longitudinal groove

usually is ready in the stone parts to be used.

[0021] In the following, the invention will be described in more detail with reference to the accompanying drawings, in which

5

Fig. 1 represents different mounting phases of one embodiment of the invention;

Fig. 2 represents different mounting phases of another embodiment of the invention; and

10

Fig. 3 represents one locking part in accordance with the invention.

15

[0022] Fig. 1 shows four different phases of the fact of how a metallic, sheet-like structural part 2 is fastened and joined with a stone part 1 having the shape of a rectangular parallelepiped. The stone part 1 includes a first straight planar surface 3, against which the sheet-like structural part 2 is fastened, and a second straight planar surface 4, which is perpendicular to the first planar surface 3. Machined on the surface of the second planar surface 4 is a groove 5 of a substantially uniform depth, which is perpendicular to the first planar surface 3, as well as perpendicular to the surface of the sheet-like structural part that comes against the stone part.

20

[0023] The locking part 6 to be used consists of a flat iron part having at the first end thereof a short fold of 90 degrees which forms a coupling element 7. Arranged in the vicinity of the second end of the locking part 6, on its both planar and wide outer surfaces, are three edge tightening elements 9, i.e. sharp edged ridges, which are at a slight angle with respect to the transverse direction of the elongated locking part.

25

30

[0024] The planar part of the metallic sheet-like structural part that comes against the first planar surface 3 includes, as a counterpart 8 of the coupling element 7, a narrow vertical opening through which the coupling element can be inserted inside, i.e. through the opening.

35

[0025] When fastening the structural part 2, which is e.g. a metallic back plate of a stove provided with a stone covering, into the stone part 1 (Fig. b), a coupling element 7 is inserted into the counterpart 8, after which the locking part 6 is turned (Fig. c) so as to be in parallel to the groove 5 on top of it, and is stretched on top of the stone part 1 as far as possible so that the parts to be attached 1 and 2 come joined with one another along their entire corresponding surfaces. After this (Fig. d), the locking part 6 is hit e.g. with a hammer substantially straight inside the groove 5. In that case, the edge tightening elements 9 engage the opposite edges of the groove, and due to the slight obliqueness of these, pull and tighten the structural part 2 tightly into the planar surface 3. A tidy, fast and firm joint is achieved.

40

45

50

55

[0026] Fig. 2 shows another embodiment of the invention in which there are two stone parts 1, and the joint is designed to join these two stone parts with one another at a right angle using an angle profile 10. Herein, in a manner as shown in Fig. 1, the locking parts 6 are attached to the counterparts of the coupling elements

that are disposed in the angle profile, i.e. the narrow, elongated openings (Fig. a). When the stone parts 1 and the angle profile 2 between them are in place (Fig. b), the locking parts 6 are hit into the grooves 5 corresponding to them, whereby the edge tightening elements tighten and lock the stone parts 1 and the angle profile 2 into each other.

[0027] As can be seen particularly from Fig. c, the counterparts of the coupling elements, i.e. the elongated openings in the angle profile, are relatively long with respect to the corresponding width of the locking part 6, substantially double. These openings extend partly into the area of the stone part to be fastened and partly above it. In this manner, the insertion of the locking parts into the openings is successful also when both the stone part and the structural part to be fastened to it already are in place.

[0028] Fig. 3 shows in more detail one locking part 6 to be used in a joint in accordance with the invention. The flat iron part, i.e. the straight, planar, thin and narrow metal strip, is, from its one end, turned into a right angle through a short distance, to form at the first end thereof a coupling element 7. In the vicinity of the second end thereof, on its both planar surfaces, are three edge tightening elements 9. They consist of straight and sharp edged ridges or projections whose straight lines are in parallel with one another. These lines are at a slightly oblique angle from the vertical direction with respect to the longitudinal direction of the locking part for implementing the desired tightening locking when hitting the locking part into the groove of the stone.

[0029] In the foregoing, the invention has been described by way of example with reference to the accompanying drawings while various embodiments of the invention are possible within the scope of the inventive idea defined by the claims.

Claims

1. A joint in a fireplace for joining a stone part (1) and a structural part (2) made of other material to one another, the stone part including a first planar surface (3), against which the structural part is fastened, and a second planar surface (4), which is at an angle against the first planar surface and which includes a groove (5) extending away from the structural part and being formed by the edges and the bottom, the joint including an elongated locking part (6), **characterised in that** the first end of the locking part (6) includes a coupling element (7) and the structural part (2) includes a counterpart (8) of the coupling element for rigidly locking the locking part and the structural part with respect to one another in the longitudinal direction of the locking part, and that substantially the one end of the locking part includes at least one edge tightening element (9) for implementing the longitudinal tightening fastening of the locking part into the edge of the groove.
2. The joint as defined in claim 1, **characterised in that** the coupling element (7) consists of the rigid fold of the first end of the locking part (6).
3. The joint as defined in claim 1, **characterised in that** the coupling element consists of a rigid hook, groove or notch.
4. The joint as defined in any one of claims 1-3, **characterised in that** the counterpart (8) of the coupling element (7) consists of a hole, opening, projection or shoulder in the structural part to which the coupling element can be coupled.
5. The joint as defined in any one of claims 1-4, the invention, **characterised in that** the locking part (6) includes at least two opposite edge tightening elements (9) for implementing the tightening fastening of the locking part in both edges of the groove.
6. The joint as defined in any one of claims 1-5, **characterised in that** the edge tightening element (9) consists of a projection, protuberance, edge or peg, which as being partly supported on the edge of the groove, implements the tightening fastening.
7. The joint as defined in any one of claims 1-6, **characterised in that** the locking part (6) consists of a metal strip, such as a flat iron.
8. The joint as defined in any one of claims 1-8, **characterised in that** the locking part consists of a metal bar, such as a sufficiently thick and rigid metal wire.
9. The joint as defined in any one of claims 1-8, **characterised in that** the first planar surface (3) and the second planar surface (4) of the structural part (2) are perpendicular to each other.
10. The joint as defined in any one of claims 1-9, **characterised in that** the groove (5) in the second planar surface (4) is straight and equal in depth.

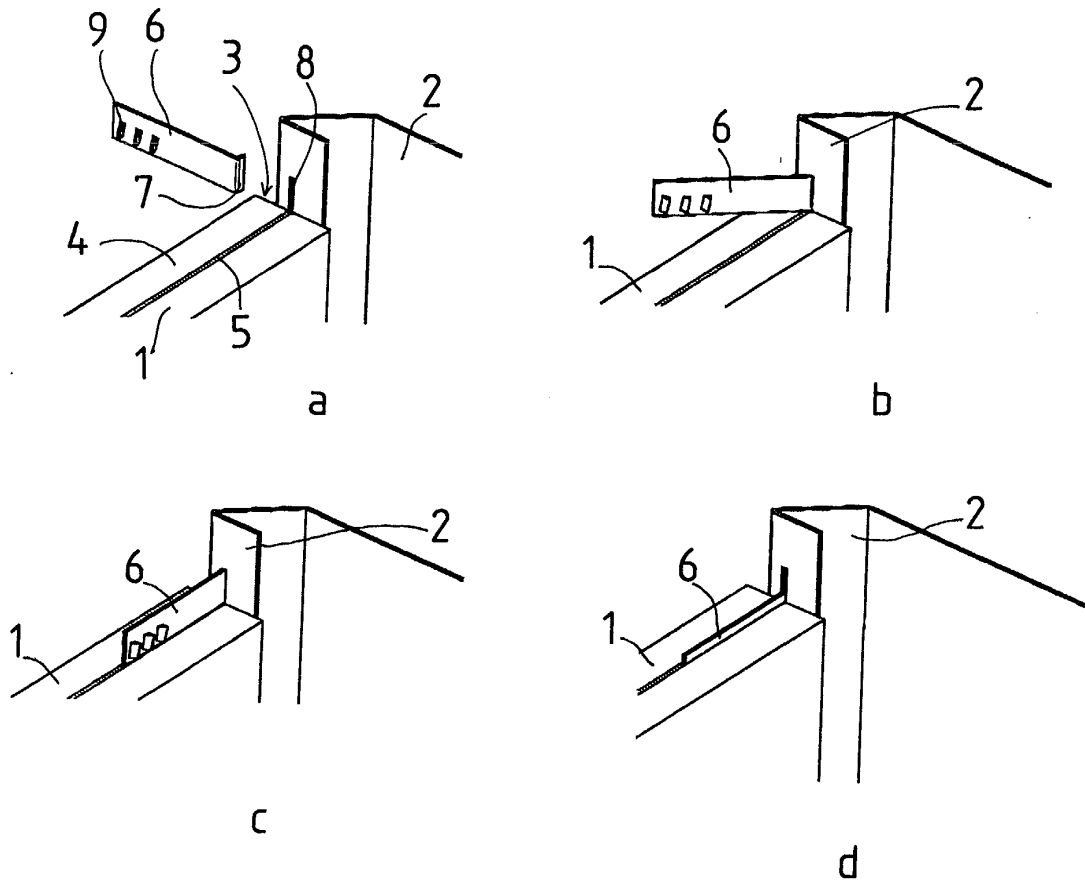

Fig 1

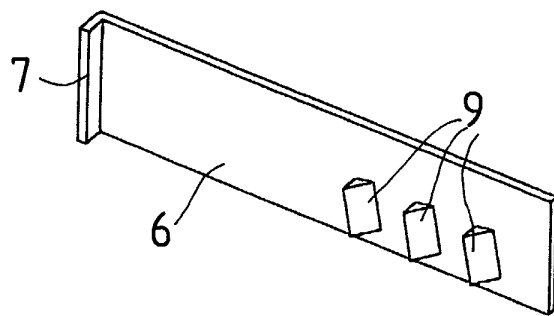
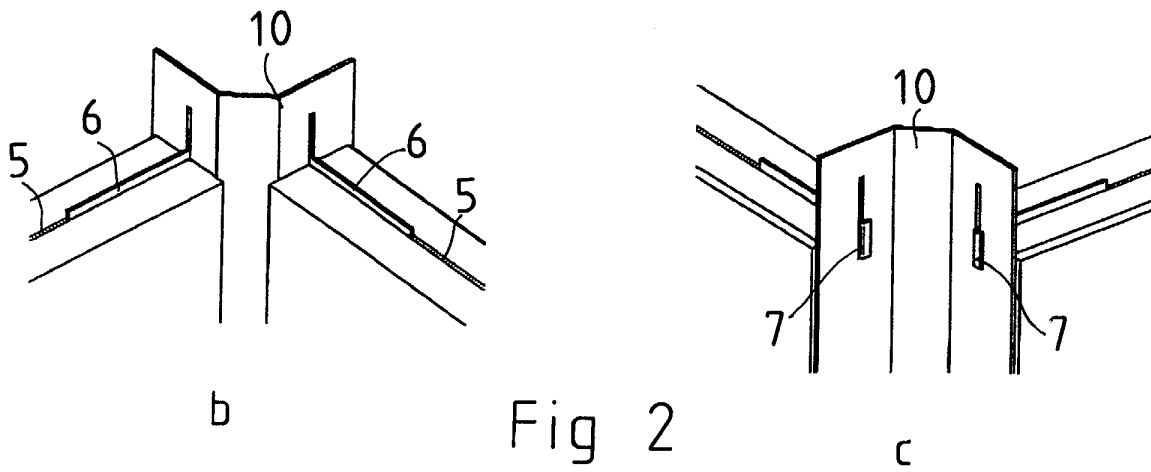
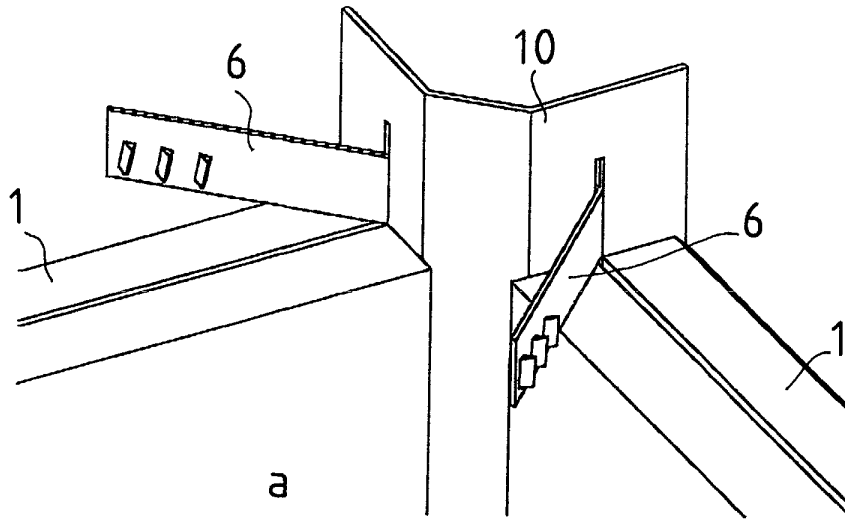

Fig 3



DOCUMENTS CONSIDERED TO BE RELEVANT			
Category	Citation of document with indication, where appropriate, of relevant passages	Relevant to claim	CLASSIFICATION OF THE APPLICATION (Int.Cl.7)
A	EP 0 745 810 A (NUNNANLAHDEN UUNI OY) 4 December 1996 (1996-12-04) * abstract *	1-8	F24B1/06
A	EP 1 236 836 A (NUNNANLAHDEN UUNI OY) 4 September 2002 (2002-09-04) * claims 8,9; figures 3,4 *	1	
A	US 3 214 802 A (DAVIS WILLIAM R) 2 November 1965 (1965-11-02) * claim 1; figure 1 *	1	
The present search report has been drawn up for all claims			TECHNICAL FIELDS SEARCHED (Int.Cl.7)
			F24B E06B
Place of search	Date of completion of the search	Examiner	
The Hague	31 August 2004	Vanheusden, J	
CATEGORY OF CITED DOCUMENTS		T : theory or principle underlying the invention	
X : particularly relevant if taken alone		E : earlier patent document, but published on, or after the filing date	
Y : particularly relevant if combined with another document of the same category		D : document cited in the application	
A : technological background		L : document cited for other reasons	
O : non-written disclosure		
P : intermediate document		& : member of the same patent family, corresponding document	

EPO FORM 1503 03 82 (P04C01)

**ANNEX TO THE EUROPEAN SEARCH REPORT
ON EUROPEAN PATENT APPLICATION NO.**

EP 04 39 6035

This annex lists the patent family members relating to the patent documents cited in the above-mentioned European search report. The members are as contained in the European Patent Office EDP file on
The European Patent Office is in no way liable for these particulars which are merely given for the purpose of information.

31-08-2004

Patent document cited in search report		Publication date	Patent family member(s)	Publication date
EP 0745810	A	04-12-1996	FI 952617 A	30-11-1996
			AT 207598 T	15-11-2001
			DE 69616152 D1	29-11-2001
			DE 69616152 T2	18-07-2002
			EP 0745810 A2	04-12-1996
EP 1236836	A	04-09-2002	EP 1236836 A2	04-09-2002
US 3214802	A	02-11-1965	NONE	