



(12) **EUROPEAN PATENT APPLICATION**
published in accordance with Art. 158(3) EPC

(43) Date of publication:
01.12.2004 Bulletin 2004/49

(51) Int Cl.7: **A44B 21/00**

(21) Application number: **03743596.3**

(86) International application number:
PCT/JP2003/002494

(22) Date of filing: **04.03.2003**

(87) International publication number:
WO 2003/073883 (12.09.2003 Gazette 2003/37)

(84) Designated Contracting States:
**AT BE BG CH CY CZ DE DK EE ES FI FR GB GR
HU IE IT LI LU MC NL PT RO SE SI SK TR**
Designated Extension States:
AL LT LV MK

(72) Inventors:
• **TAKAHASHI, Yoshinobu**
Uozu-shi, Toyama 937-0857 (JP)
• **SUGIHARA, Koki**
Saitama-shi, Saitama 330-0014 (JP)

(30) Priority: **06.03.2002 JP 2002060949**

(74) Representative:
Luckhurst, Anthony Henry William
MARKS & CLERK,
57-60 Lincoln's Inn Fields
London WC2A 3LS (GB)

(71) Applicant: **YKK Corporation**
Chiyoda-ku, Tokyo 101 8642 (JP)

(54) **MALE FIXING MEMBER OF HOOK-AND LOOP FASTENER, AND SHEET PRODUCT WITH THE FIXING MEMBER**

(57) A first base material having a number of male engaging elements (112) formed of synthetic resin on a surface thereof and a second base material (121) are jointed and secured each other through a column-like joint portion (122). There is provided a male fixing mem-

ber for sheets, which facilitates attachment operation to clothes or suspension cloths, has a durability, never loses appearance when it is mounted on clothes and allows even an infant to engage or disengage the male fixing members easily by an engagement/disengagement function of a surface fastener.

FIG. 4

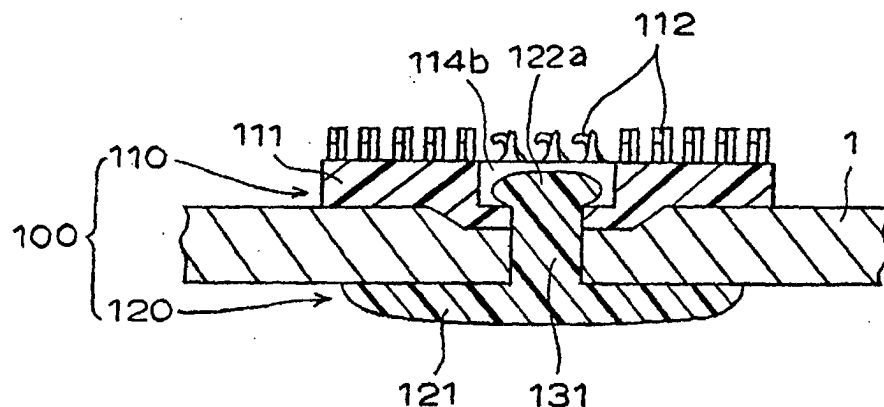

Description

TECHNICAL FIELD

[0001] The present invention relates to a male fixing member which is attached to clothes such as outdoor wears and various kinds of shirt and suspension cloth such as a curtain and a table skirt and has a number of male engaging elements allowing engagement and disengagement thereof to a mating member through an engaging/disengaging mechanism of a surface fastener, and relates to a sheet product such as clothes and suspension screen to which the male fixing members are attached.

BACKGROUND ART

[0002] Conventionally, various kinds of fixing devices have been used at an opening/closing portion of clothes and an engaging/disengaging portion for a curtain and a runner. Its typical fixing device is buttons. As extremely ordinary buttons, there are buttons used for outdoor wears, shirts and blouses. According to this device, a button main body fixed to one side of the opening/closing portion of clothes with threads is inserted into a slit-like button hole formed in the other side of the opening/closing portion or pulled out through the button hole so as to open or close the opening/closing portion. However, these ordinary buttons require opening/closing operation of inserting the button into the button hole so as to close the opening/closing portion or pulling out the button through the button hole so as to open the opening/closing portion. These operations are very difficult for infants, persons handicapped in finger action and aged persons although not for healthy adults and therefore, the buttons are fixing devices very difficult to handle.

[0003] As a fixing device capable avoiding such a complicated matter in the operation, for example, snap buttons often used for jumpers, jeans and the like are available. This snap button comprises a male device and a female device and the male and female devices are engaged or disengaged through an easy operation of pressing them against their elasticity with the fingers and pulling both in the direction of departing from each other respectively. However, the snap button cannot be in an excellent engagement unless the male device and female device are aligned with each other in the center and pressed together. That is, like the aforementioned ordinary buttons, this snap button is a very difficult fixing device for persons handicapped in the finger action or eyesight, infants and aged persons.

[0004] To eliminate such an inconvenience, fixing devices for clothes have been proposed through, for example, Japanese Utility Model Registration No. 3081450, or Japanese Utility Model Registration No. 3082944. For the latter, a surface fastener is fixed to a surface of a button made of synthetic resin having ordinary thread through hole with adhesive agent or by ul-

trasonic fusion, and such buttons are sewed by sewing threads to the opening/closing portion of clothes so as to oppose each other. On the other hand, regarding the former, a surface fastener comprising a substrate and engaging elements is disposed on a back side of the opening/closing portion of a side having ordinary buttons while an ordinary button having a thread through hole is disposed on a surface of the same button hole. Then, the surface fastener and button are jointed through the sewing thread so that the surface fastener is disposed on the back side of the opening/closing portion, thereby the button is attached to a surface side of the opening/closing portion through the button hole.

[0005] The invention according to each of the above-described registered Utility Models is effective in that the engagement/disengagement operation is facilitated as compared to a conventional button or snap button because their joining/separations are enabled in a wide area by using a joining mechanism based on the surface fastener. However, the attachment operation is complicated and its practical usage is difficult in terms of durability and appearance.

[0006] That is, according to the fixing device disclosed in the above-mentioned Japanese Utility Model Registration No. 3081450, a substrate made of synthetic resin having the engaging elements on a surface thereof is jointed with the button through the sewing thread and the button is attached on the clothes through the button hole formed in the opening/closing portion of the clothes. Thus, the sewing thread which joints the substrate with the button is easy to cut out due to repeated usage or washing and thus, the durability is low.

[0007] According to the fixing device disclosed in the Japanese Utility Model Registration No. 3081450, the button made of synthetic resin having the surface fastener on a surface thereof is sewed on the opening/closing portion of the clothes with the sewing thread so that respective surface fasteners oppose each other. Thus, an end of the sewing thread is exposed on the surface of clothes so that not only the appearance is damaged but also that end of the thread is likely to be caught by other things and cut out.

[0008] According to both of the above-described inventions, two buttons are always attached to the fixing device attachment portion installed on the opening/closing portion of clothes such that they overlap each other. Consequently, when the opening/closing portion is closed, only that fixing device mounting portion swells, so that the appearance beauty deteriorates, which is not suitable for practical usage.

[0009] The present invention has been achieved to solve these conventional problems and more specifically, an object of the present invention is to provide a male fixing member for sheets, which can be manufactured easily, is easy to install on clothes or a suspension cloth, is durable for long-term usage and when it is installed on clothes, does not deteriorate the appearance beauty and can be engaged or disengaged easily by even an

infant.

DISCLOSURE OF THE INVENTION

[0010] A basic configuration of the present invention exists in a male fixing member which engages/disengages sheet faces of sheet members through a surface fastener engaging/disengaging mechanism, comprising a first base material and a second base material, which are disposed so as to oppose each other, wherein a surface of the first base material has a plurality of male engaging elements and a rear face of the first base material and the second base material are jointed together through a column-like joint portion. Preferably, the column-like joint portion is molded integrally with any one of the first base material or the second base material.

[0011] The flat first base material and second base material of the present invention may be constituted of any of synthetic resin material and metallic material and the first base material has a number of engaging elements on the surface of the first base material. This engaging element can be formed in any form of hook, palm tree, mushroom and their modified forms and as the molding figuration, it is permissible to adopt diversified well known molding methods such as ordinary injection molding, continuous injection molding, and molding from synthetic resin linear material (mono-filament).

[0012] In case not only where the column-like joint portion of a fixing portion is made of metal, but also where it is made of synthetic resin, the stability for maintenance of the configuration, its tensile strength and shearing strength are by far higher than sewing threads. Therefore, it is never removed or damaged easily after it is mounted on clothes or suspension cloths and thus, is highly durable for long-term repeated usage. Further, because the requirement of the first base material and the second base material is only to possess an appropriate stiffness (hardness), it is possible to mold them to be very thin depending on selection of material. As the material, it is permissible to use not only metallic material such as copper, aluminum alloy, but also various kinds of thermoplastic resin material such as polyolefin, polystyrene, polyamide, polyester.

[0013] Although the column-like joint portion may be formed independently of the first base material and the second base material, it is preferable that it is molded integrally with any one of the first base material and the second base material preliminarily from viewpoint of easiness of mounting on a sheet member.

[0014] Further according to the present invention, it is permissible that the male engaging elements formed on the surface of the first base material are composed of hook pieces and a number of the hook pieces are disposed on plural sectioned engaging areas on the surface of the first base material while engaging directions of the male engaging elements are different between adjacent engaging areas. Although generally the engaging elements composed of the hook pieces have a

directivity, according to the present invention, these engaging elements are disposed in plural sectioned engaging areas while the engaging directions of the engaging elements are different between the adjacent engaging areas. Consequently, the engaging direction on the surface of the first base material is not deviated to one direction but engagement in all directions is enabled. According to the present invention, even for the engaging elements disposed in multiple columns in each engaging area, the engaging direction of the engaging elements can be made different between the adjacent columns.

[0015] Further according to the present invention, preferably, the first base material and the second base material are formed integrally through the column-like joint portion. That is, the characteristic feature of the present invention exists in that the male fixing member is formed such that the first and second base materials of its components are formed integrally with the column-like joint member which connects those base materials. Because the first and second base materials and the column-like joint portion which connects these base materials are formed integrally regardless of whether they are made of metal or synthetic resin, a process for jointing the second base material and the first base material through the column-like joint portion becomes unnecessary, thereby leading to a remarkable increase in productivity.

[0016] When mounting the male fixing member of the present invention, which has male engaging elements formed on the surface of the first base material with an appropriate means, on an opening/closing portion of clothes or a suspending portion of a suspension cloth, a slit-like hole is formed in the mounting portion of the male fixing member and then, the first or second base material is inserted through the hole so that the hook-like engaging elements are exposed outside.

[0017] Further, according to the present invention, under the above-described structure, the first base material and the male engaging elements are formed of synthetic resin material while the first base material and the male engaging elements are molded integrally. According to the present invention, regardless of whether the first base material is molded integrally with the column-like joint portion or the first base material is formed independently, in case of the first base material composed of synthetic resin material, a number of male engaging elements are molded integrally with the first base material at the time of molding. With such a structure, not only productivity can be raised but also as compared to a case where the male engaging elements and the first base material are formed independently and integrated later, a phenomenon that the male engaging elements may be separated from the first base material is eliminated despite repeated usage and durability can be ensured.

[0018] Further, according to the present invention, the first base material may be constituted of metallic mate-

rial and a male surface fastener piece having the male engaging elements is bonded to a surface of the first base material. The first base material is constructed of, for example, circular or polygonal thin metallic piece and possesses an insertion hole, through which the front end of the column-like joint portion can be inserted, in the center of the first base material. A male surface fastener piece having a number of the aforementioned male engaging elements is bonded to a surface of the metallic piece so that they are integrated.

[0019] In this case, the joint portion is pierced into a sheet product, a front end portion of the joint portion is inserted through the insertion hole from a rear face toward the front surface of the first base material and the projecting end portion is deformed plastically so that it is expanded in a direction perpendicular to an axial direction of the joint portion. Consequently, it is attached to the sheet product under conditions in which a fixing portion and a fastening portion are integrated. Because the male fixing member of the surface fastener of the present invention attached in this way is mounted securely on the sheet product and further, the column-like joint portion has a high tensile strength and shearing strength, it is never damaged easily by repeated usage and washing. Meanwhile, not only the first base material but also the fastening portion can be formed of any one of metallic material and synthetic resin material.

[0020] Further, preferably, the front end portion of the column-like joint portion has an engaging/disengaging head portion and the joint portion of the first base material or the second base material which is to be fixed with the column-like joint portion has an engaging/disengaging portion which allows engagement/disengagement of the column-like joint portion with/from the engaging/disengaging head portion. The engaging/disengaging portion which the engaging/disengaging head portion engages or disengages is preferred to be constructed in the same structure as the snap structure in the snap button. With such a structure, after the column-like joint portion is pierced into the sheet product, the first base material and the second base material can be integrated easily with a simple action by pressing with the fingers and if necessary, they can be removed easily if they are pulled in the direction of departing.

[0021] Further, according to the present invention, the front end portion of the column-like joint portion has a structure deformable plastically in a diameter expanding direction perpendicular to the axial line of the joint portion and the joint portion of the first base material or the second base material, which is integrated with the column-like joint portion, has an attaching portion which receives the front end portion of the column-like joint portion and when the front end portion is deformed plastically, the deformed portion is attached and secured to. As for the plastic deformation of the front end portion of the column-like joint portion, if the joint portion is constituted of metallic material, the joint portion is formed cylindrically and the front end portion desired to be de-

formed plastically is divided to four sections along a circumference direction and then by pressing the front end portion in an axial direction, it can be bent easily in the direction of expanding the diameter. Consequently, the bent end portions are attached to the attaching portion. Further, if the column-like joint portion is formed of synthetic resin material, by heating the front end portion with a pressure, it is expanded and the expanded portion is attached to the attaching portion.

[0022] Further, preferably, the first base material or the second base material has an insertion hole for the column-like joint portion in the center, and has an expanded portion provided around the insertion hole and plural sliding preventing protrusions provided around the expanded portion at a predetermined interval. The expanded portion around the insertion hole not only secures the strength of the surrounding of the insertion hole, but also increases a nipping strength for the sheet member, so that the male fixing member of the present invention can be fastened to the sheet member firmly. Further, at the time of fastening, the plural protrusions around the expanded portion bite into the sheet member thereby preventing the male fixing member from sliding on the sheet member.

[0023] Further, the present invention concerns a sheet product characterized in that the male fixing member described above is attached to a joining portion of the sheet member through the column-like joint portion. The sheet products include clothes such as various kinds of shirts and outdoor wears and the mounting position of the male fixing member is an opening/closing portion of the clothes. In addition to clothes, a suspension cloth of a curtain or a table skirt to be attached to the periphery of a table is also included. The mounting position of the male fixing member is a suspending portion of the suspension cloth. Other sheet products include for example, tapestry.

BRIEF DESCRIPTION OF THE DRAWINGS

[0024]

FIG. 1 is a front view showing a male fixing portion of a male fixing member according to the first embodiment of the present invention;

FIG. 2 is a rear view of the same;

FIG. 3 is a sectional view taken along the line III-III in FIG. 1;

FIG. 4 is a partial sectional view of clothes to which the male fixing member of the present invention of the first embodiment is attached;

FIG. 5 is a partial sectional view of clothes to which the male fixing member according to a modification of the present invention is attached;

FIG. 6 is a partial sectional view of clothes to which the male fixing member according to the second embodiment of the present invention is attached;

FIG. 7 is a sectional view of the male fixing member

according to the third embodiment of the present invention;

FIG. 8 is a partial sectional view of clothes to which the male fixing member according to a modification of the third embodiment is attached;

FIG. 9 is a partial sectional view of clothes to which the male fixing member according to the fourth embodiment of the present invention is attached;

FIG. 10 is a partial perspective view of a half coat to which the male fixing member of the present invention is attached; and

FIG. 11 is a perspective view showing partially a combination of a curtain to which the male fixing member of the present invention is attached and a curtain runner.

BEST MODE FOR CARRYING OUT THE INVENTION

[0025] Hereinafter, the preferred embodiments of the present invention will be described in detail based on the represented examples.

[0026] FIGS. 1 to 4 show the male fixing portion of the male fixing member according to the first embodiment of the present invention and FIG. 1 is a front view thereof, FIG. 2 is a rear view thereof and FIG. 3 is a sectional view taken along the line III-III in FIG. 1 and FIG. 4 is a sectional view showing a condition in which the male fixing member is attached to a fabric of clothes.

[0027] As shown in FIG. 4, a male fixing member 100 of the present invention comprises a male fixing portion 110 and a fastening portion 120. The male fixing portion 110 is constituted of a male member which comprises a first base material 111 composed of a button-like flat piece and a number of male engaging elements 112 projecting from a surface of the base material, and the male member joins with or separates from a loop piece as a mating engaging member of the surface fastener and is generally called male surface fastener. The male fixing portion of this embodiment is obtained directly by injection molding of thermoplastic synthetic resin material. As the synthetic resin material, it is possible to use various kinds of thermoplastic synthetic resin having some extent of hardness (stiffness) after molding such as polystyrene, poly amide, polyester although it varies depending on its application purpose.

[0028] As shown in FIGS. 1 to 3, the first base material 111 of this embodiment is constituted of an octagonal flat piece and a number of engaging elements 112 molded integrally when the first base material 111 is molded stand on a flat surface in its plan view. According to the indicated example, as for the configuration of each engaging element 112, a main body 112a stands up like a hook while isosceles triangle-like reinforcement rib 112b having substantially the same height as the main body 112a is formed integrally on a side face of the main body 112a in a closely contact condition.

[0029] On the other hand, the first base material 111 has a disc-like expanded portion 113 in a center of a

rear surface and a joint portion insertion hole 114, which a column-like joint portion 131 of a fastening portion 120 is inserted through and will be described in detail later, is formed in a center of the expanded portion. The joint portion insertion hole 114 comprised a circular hole portion 114a having substantially equal diameter as the outside diameter of the column-like joint portion 131 and a square hole portion 114b communicating with the circular hole portion through a step portion 114c. The length of a single side of this square hole portion 114b is set to be larger than the diameter of the circular hole portion 114a and the step portion 114c is formed on the boundary face. Further, a plurality of sliding preventing protrusions 115 are provided protrudingly at a predetermined interval around the expanded portion 113.

[0030] As shown in FIG. 4, the fastening portion 120 of this embodiment comprises a flat second base material 121 and the column-like joint portion 131 erected integrally from the central portion of the front face of the second base material. Because the second base material 121 is exposed outside when the male fixing member 100 is attached to clothes or the like, it is desirable to apply diversified colors or patterns on the surface thereof and its shape is not limited to a circular one but can be formed into any shape such as polygonal one. According to the example shown in FIG. 4, the fastening portion 120 is formed by injection molding of thermoplastic synthetic resin like the male fixing portion 110.

[0031] When the male fixing member 100 having such a structure shown in the same Figure is attached to clothes 1 as shown in FIG. 9, first, the second base material 121 of the fastening portion 120 is exposed outside, and then the column-like joint portion 131 is pierced into a specific position at the opening/closing portion of the clothes. Further, the front end portion of the pierced column-like joint portion 131 is inserted into the joint portion through hole 114 of the male fixing portion 110 so that it is introduced from the circular hole portion 114a to the square hole portion 114b. When this insertion ends, the front end portion projecting from the square hole portion 114b is heated by pressing in an axial direction to soften by a heating and pressing member (not shown), deformed plastically in the direction for expanding the diameter and then hardened by cooling. This expanded portion 122a is attached to the step portion 114c between the circular hole portion 114a and the square hole portion 114b as shown in FIG. 4, so that the male fixing portion 110 and the fastening portion 120 are joined together integrally and attached to the clothes.

[0032] When a face having the engaging elements 112 of the male fixing member 100 of this embodiment attached in such a manner is pressed against a female surface fastener piece (not shown) having a number of loop pieces, the female surface fastener attached to the opening/closing portion of the mating member, both can be joined together through faces securely even if there is a slight deflection in position. Further, because the male fixing portion 110 and the fastening portion 120 are

integrated through the column-like joint portion 131 having a mechanical strength, once mounted, there is no fear of being damaged even if the opening/closing portion of clothes or the like is engaged or disengaged repeatedly and further even if a violent external force is applied at the time of washing.

[0033] FIG. 5 shows a modification of the present invention. According to this modification, the aforementioned column-like joint portion 131 is formed by injection molding such that it is erected from a central portion of a face of the first base material 111, the face opposite to a face on which the male engaging elements 112 are formed. On the other hand, a disc-like expanded portion 123 which is identical to the first embodiment is possessed in the central portion of the second base material 111 and a joint portion insertion hole 124, through which the column-like joint portion 131 of the male fixing portion 110 is to be inserted, is formed through in the center thereof. This joint portion insertion hole 124 comprises a circular hole portion 124a having substantially the same diameter as the outside diameter of the column-like joint portion 131 and a square hole portion 124b communicating with the circular hole portion through a step portion 124c. The length of one side of this square hole portion 124b is set to be larger than the diameter of the circular hole portion 124a and the step portion 124c is formed on the boundary face. Further, a plurality of sliding preventing protrusions 125 are provided protrudedly at a specific interval around the expanded portion 123. The engaging/disengaging operation to a sheet member (not shown) is the same as the first embodiment.

[0034] FIG. 6 shows the second embodiment of the present invention. Although according to this embodiment, the structure of the male fixing portion 110 is substantially not different from the first embodiment, material used for the fastening portion 120 is for example, alloy of copper or iron or the like and basically, it is constructed of a combination of plural components obtained by sheet metal processing. According to the indicated example, like an ordinary metallic ornament button, a cylindrical portion 126a of a bottomed cylindrical member 126, which is a column-like joint portion, is divided to plural sections along a circumferential direction and divided pieces 126b are bent to substantially horizontally from a bottom portion 126d alternately so that they are radiated in a wavelike shape respectively. The peripheral edge of a metallic cap 127, which is a disc-like second base material, is wound inwardly and fixed to the front ends of the divided pieces 126b extending radially.

[0035] When this is fixed to a male fixing portion 110 having the same structure as the first embodiment through base fabric of the clothes 1, first, the metallic cap 127, which is the second base material, of the fastening portion 120 is exposed outside and then, the cylindrical member 126 which is its column-like joint portion is pierced into an opening/closing portion of clothes.

Further, the front end portion of the pierced cylindrical member 126 is inserted into a joint portion insertion hole 114 of the male fixing portion 110 so that it is introduced from a circular hole portion 114a to a square hole portion 114b. When this insertion ends, the front end of the cylindrical member 126 projecting from the square hole portion 114b is pressed mechanically with a pressing member (not shown) so that it is bent outward. As shown in FIG. 5, a bent portion 126c is attached to a step portion 114c between the circular hole portion 114a and the square hole portion 114b and consequently, the male fixing portion 110 and the fastening portion 120 are integrated and attached to clothes 1.

[0036] FIG. 7 shows a third embodiment of the present invention. According to this embodiment, the entire male fixing member 100 is formed integrally of the same synthetic resin material. That is, as indicated in the same Figure, the first base material 111, the engaging elements 112, the column-like joint portion 131 and the second base material 121 are all molded integrally. When attaching the male fixing member 100 having such a structure to the clothes 1, a slit-like button hole 1a is formed in the attachment portion of the clothes 1 as shown in the same Figure, for example, and the second base material 121 of the fastening portion 120 is inserted from an inside face side of the button hole 1a, and exposed outside and attached.

[0037] FIG. 8 shows an example of modification that most portion of the male fixing member 100 of the present invention except the above engaging elements 112 is molded integrally with metallic material at the same time. A difference of this modification from the above-described third embodiment is that a male synthetic resin made surface fastener 116, in which a plurality of the engaging elements 112 are molded integrally on a base plate 116a made of a thin plate, is formed preliminarily and then the synthetic resin made surface fastener 116 is bonded to the first base material surface of the first base material 111, the column-like joint portion 131 and the second base material 121 composed of metallic material molded integrally by die-casting and the like, with adhesive agent. In this case, as the adhesive agent, it is permissible to use marketed hot melt adhesive agent or instant adhesive. In the meantime, as the aforementioned male synthetic resin made surface fastener 116, it is permissible to use, for example, a conventionally well known fiber made surface fastener having hook-like engaging elements constituted of synthetic resin mono-filaments, which are woven into a fiber woven fabric or knit fabric.

[0038] FIG. 9 shows the fourth embodiment of the present invention. Although according to the first to third embodiments, the male fixing portion and the fixing portion, which are components of the male fixing member of the present invention, are integrated fixedly through the column-like joint portion, according to this embodiment, the male fixing portion 110 and the fastening portion 120, which are components of the male fixing mem-

ber 100, are so constructed to be capable of engaging or disengaging from each other through the column-like joint portion 131 easily with a single touch of a button. Meanwhile, according to this embodiment, mushroom shaped engaging elements are used as the male fixing elements 12.

[0039] Although in the indicated example, the structure of the male fixing portion 110 is the same as the first embodiment, the front end portion of the column-like joint portion 131 erected integrally from the fastening portion 120 has an engaging/disengaging head portion 131a, which is expanded in a diameter direction and divided to plural sections along the axial line. The maximum diameter of this engaging/disengaging head portion 131a is larger than the diameter of the circular hole portion 114a of the joint portion insertion hole 114 of the first base material 111 and smaller than the length of a single side of the square hole portion 114b. In addition, the diameter when contracted is set to be smaller than the diameter of the circular hole portion 114a. In the meantime, according to this embodiment, although the entire male fixing member 100 is constituted of synthetic resin material, other members except the aforementioned engaging elements 112 can be constituted of metallic material or by combination of synthetic resin material and metallic material.

[0040] When attaching the male fixing member having the above-described structure to the clothes 1, a hole 1b which allows the column-like joint portion 131 to pass through, is made preliminarily in the opening/closing portion of the clothes 1 and with the second base material 121 of the fastening portion 120 exposed outside, the column-like joint portion 131 is inserted into the aforementioned hole 1b and pressed into the circular hole portion 114a of the first base material 111 by contracting the engaging/disengaging head portion 131a at the front end portion elastically. When the engaging/disengaging head portion 131a passes the circular hole portion 114a, the engaging head portion 131a is restored to its original shape elastically and attached to the step portion 114c, so that the male fixing member 100 can be attached to the clothes 1. When detaching this from the clothes 1, the first and second base materials 111, 121 are pulled from each other in the direction of leaving each other with the fingers and consequently, the engaging head portion moves in an opposite direction, so that the second base material 121 can be separated from the first base material 111.

[0041] FIG. 10 shows a half coat provided with the male fixing members 100 of the present invention and female fixing members 30. According to this indicated example, the male fixing members 100 of the present invention are attached along an edge portion of a fly portion which is to overlap the outside, at a predetermined interval with the fixing portions 110 exposed outside and the male engaging elements 112 of the surface fastener fixed integrally to the first base material 111 are disposed on the inside. On the other hand, at positions cor-

responding to the male fixing members 100 along the edge portion to overlap the inside of the fly portion, the female fixing members 30 which are ordinary female fastener pieces having a plurality of loop pieces on a surface are attached by sewing or the like.

[0042] FIG. 11 shows a curtain 20 provided with the male fixing member 100 of the present invention and the female fixing member 30. According to the indicated example, the male fixing members 100 of the present invention are attached to the top edge of the curtain 20 at a desired interval, while the female fixing members 30 composed of ordinary female fastener pieces having a plurality of loop pieces on their surfaces respectively are attached to a number of curtain runners 21, the number equivalent to that of the male fixing members 100 which are mounted on the curtain 20, with adhesive agent or the like.

[0043] If as shown in FIGS. 10 and 11, the male fixing members 100 of the present invention are attached to a half coat 10 or a curtain 20 while the female fixing members 30 are attached to an attachment portion of a mating member, the joining operation is facilitated for a person handicapped in finger action or eyesight because the attachment area is large. Further, if appropriate configuration, dimensions and material are selected for the male engaging elements, not only a sufficient attachment strength is obtained, but also a sufficient bonding force is obtained, so that the bonding is never released easily. If it is intended to release the attachment, it can be released easily.

[0044] Although typical examples of the present invention have been presented in the above description, the present invention is not restricted to these embodiments and modifications, but diversified materials can be combined. In addition, needless to say, the present invention can be modified in various ways within a scope described in claims attached to this specification.

40 Claims

1. A male fixing member (100) which engages/disengages sheet faces of sheet members through a surface fastener engaging/disengaging mechanism, **characterized in that**
 - the male fixing member comprises a first base material (111) and a second base material (121), which are disposed so as to oppose each other, and a column-like joint portion (131),
 - a surface of the first base material (111) has a plurality of male engaging elements (112), and
 - a rear face of the first base material (111) and the second base material (121) are jointed together through the column-like joint portion (131).
2. The male fixing member according to claim 1, **characterized in that** the column-like joint portion (131) is molded integrally with any one of the first base

material (111) and the second base material (121).

3. The male fixing member according to claim 1, **characterized in that** the male engaging elements (112) formed on the surface of the first base material (111) are composed of hook pieces and a number of the hook pieces are disposed on plural sectioned engaging areas on the surface of the first base material (111) while engaging directions of the male engaging elements (112) are different between adjacent engaging areas.
4. The male fixing member according to claim 1, **characterized in that** the first base material (111) and the second basematerial (121) are formed integrally through the column-like joint portion (131).
5. The male fixing member according to claim 1, **characterized in that** the first base material (111) and the male engaging elements (112) are formed of synthetic resin material while the first base material (111) and themale engaging elements (112) are molded integrally.
6. The male fixing member according to claim 1, **characterized in that** the first base material (111) is constituted of metallic material and a male surface fastener piece having the male engaging elements (112) is bonded to a surface of the first base material.
7. The male fixing member according to claim 1, **characterized in that** a front end portion of the column-like joint portion (131) has an engaging/disengaging head portion (131a) and a joint portion of the first base material (111) or the second base material (121) which is fixed with the column-like joint portion (131) has an engaging/disengaging portion (114c, 121c) which allows engagement/disengagement with/from the engaging/disengaging head portion (131a) of the column-like joint portion (131).
8. The male fixing member according to claim 1, **characterized in that** a front end portion of the column-like joint portion (131) has a structure deformable plastically in a diameter expanding direction perpendicular to an axial line of the column-like joint portion (131) and
 a joint portion of the first base material (111) or the second base material (121), which is integrated with the column-like joint portion (131), has an attaching portion (114c, 124c) which receives the front end portion of the column-like joint portion (131) and when the front end portion is deformed plastically, a deformed portion (131a) is attached and secured to.
9. The male fixing member according to claim 1, **char-**

acterized in that any one of the first base material (111) and the second base material (121) has an insertion hole (114, 124) for the column-like joint portion (131) in a center thereof, and has an expanded portion (113, 123) provided around the insertion hole (114, 124) and plural sliding preventing protrusions (115, 125) provided around the expanded portion (113, 123) with a predetermined interval.

10. A sheet product, **characterized in that** the male fixing member (100) according to any one of claims 1 to 9 is attached to a joining portion of any one of sheet members through the column-like joint portion (122).
11. The sheet product according to claim 10, **characterized in that** the sheet members are clothes (10) and the joining portion is an opening/closing portion of the clothes (10).
12. The sheet product according to claim 10, **characterized in that** the sheet members are ones of various kinds of suspension cloths (20) and the joining portion is a suspending portion of the suspension cloth (20).

FIG. 1

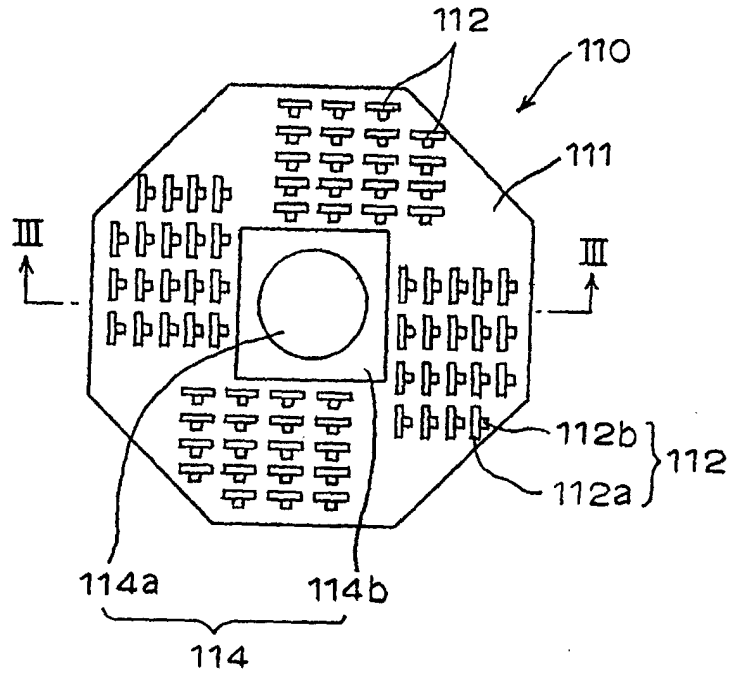

FIG. 2

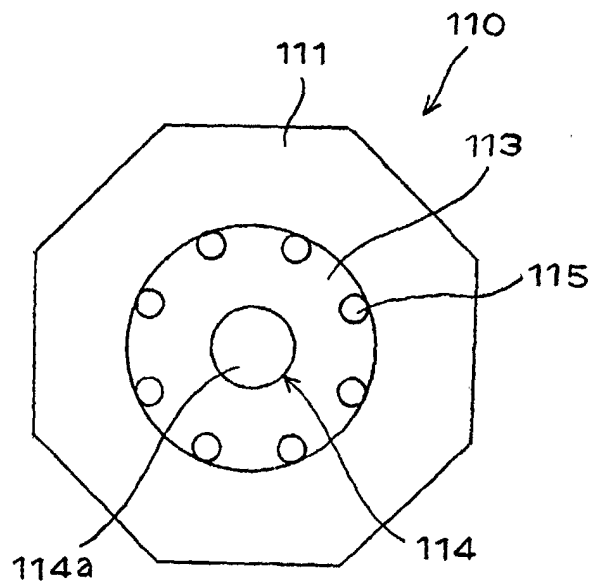

FIG. 3

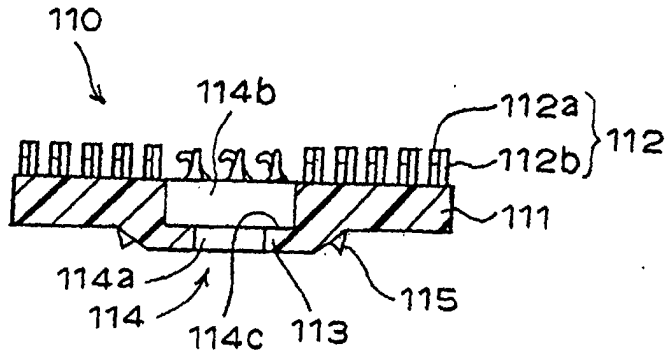

FIG. 4

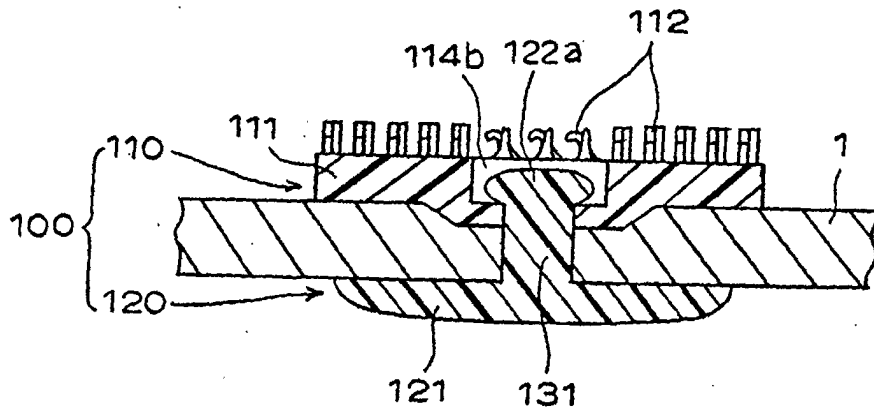

FIG. 5

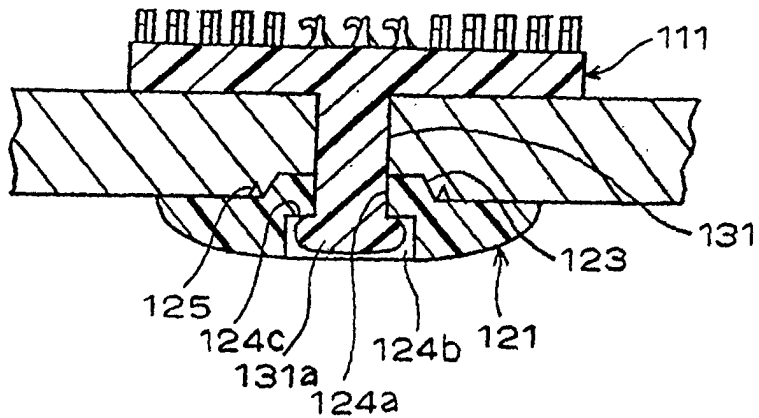

FIG. 6

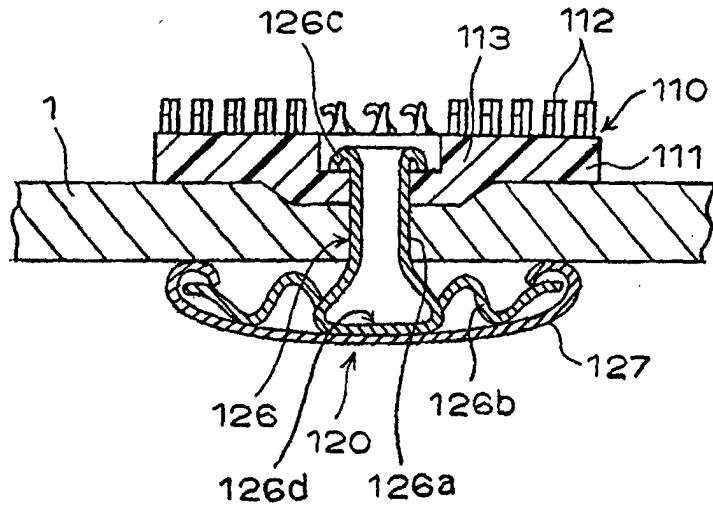

FIG. 7

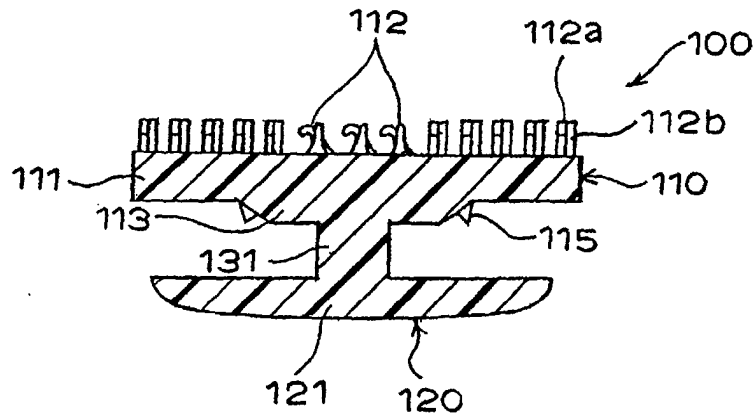

FIG. 8

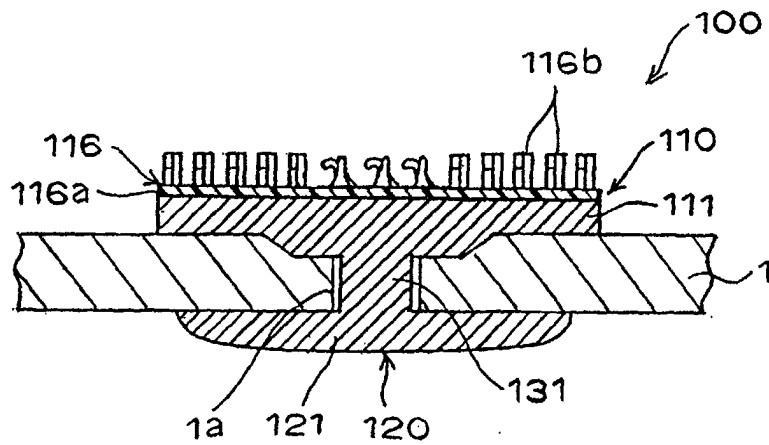

FIG. 9

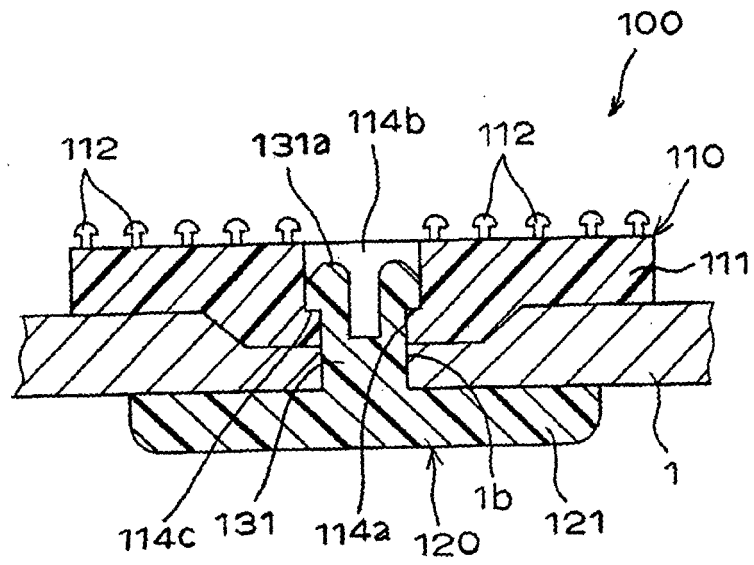

FIG.10

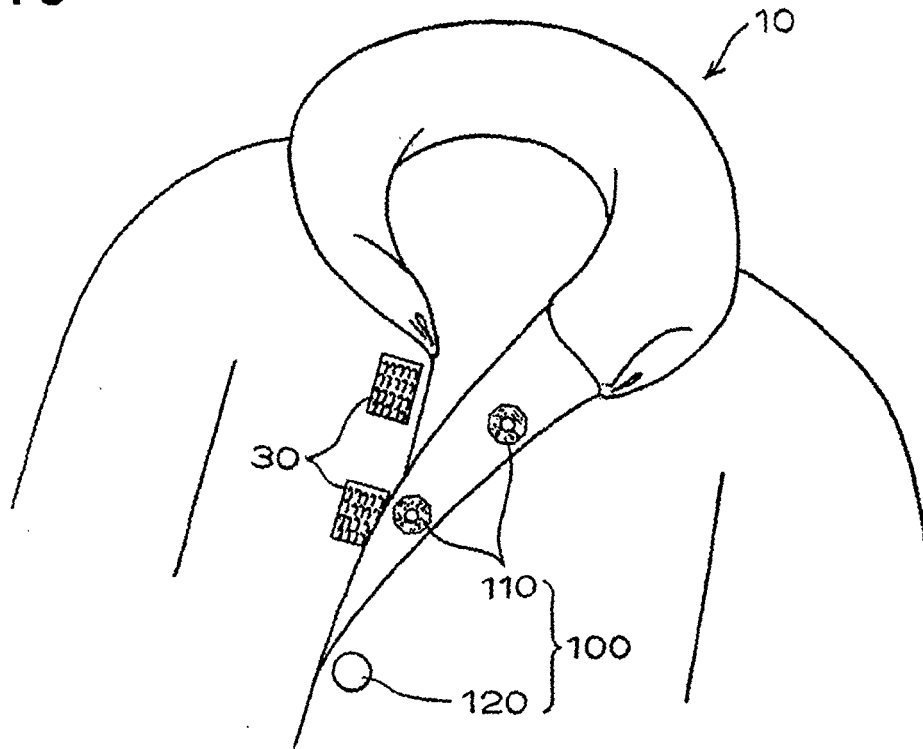
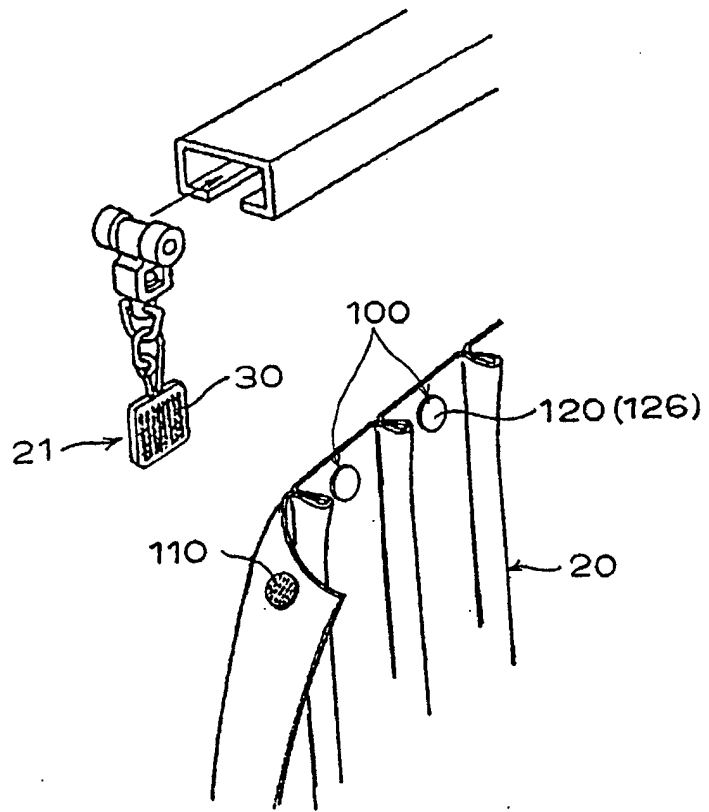

FIG.11



INTERNATIONAL SEARCH REPORT

International application No.

PCT/JP03/02494

A. CLASSIFICATION OF SUBJECT MATTER Int.Cl ⁷ A44B21/00		
According to International Patent Classification (IPC) or to both national classification and IPC		
B. FIELDS SEARCHED		
Minimum documentation searched (classification system followed by classification symbols) Int.Cl ⁷ A44B18/00, 21/00		
Documentation searched other than minimum documentation to the extent that such documents are included in the fields searched Jitsuyo Shinan Koho 1926-1996 Toroku Jitsuyo Shinan Koho 1994-2003 Kokai Jitsuyo Shinan Koho 1971-1996 Jitsuyo Shinan Toroku Koho 1996-2003		
Electronic data base consulted during the international search (name of data base and, where practicable, search terms used)		
C. DOCUMENTS CONSIDERED TO BE RELEVANT		
Category*	Citation of document, with indication, where appropriate, of the relevant passages	Relevant to claim No.
X	JP 2000-157312 A (YKK Corp.), 13 June, 2000 (13.06.00), (Family: none)	1-2, 4-7, 10-12 3, 8, 9
Y		
X	EP 1084643 A2 (YKK Corp.), 21 March, 2001 (21.03.01), & JP 2001-78810 A & CN 1288701 A	1-2, 4, 5, 7, 10-12 3, 8, 9
Y		
Y	Microfilm of the specification and drawings annexed to the request of Japanese Utility Model Application No. 54414/1991 (Laid-open No. 133711/1992) (Kuraray Co., Ltd.), 11 December, 1992 (11.12.92), (Family: none)	3
<input checked="" type="checkbox"/> Further documents are listed in the continuation of Box C. <input type="checkbox"/> See patent family annex.		
* Special categories of cited documents: "A" document defining the general state of the art which is not considered to be of particular relevance "E" earlier document but published on or after the international filing date "L" document which may throw doubts on priority claim(s) or which is cited to establish the publication date of another citation or other special reason (as specified) "O" document referring to an oral disclosure, use, exhibition or other means "P" document published prior to the international filing date but later than the priority date claimed		"I" later document published after the international filing date or priority date and not in conflict with the application but cited to understand the principle or theory underlying the invention "X" document of particular relevance; the claimed invention cannot be considered novel or cannot be considered to involve an inventive step when the document is taken alone "Y" document of particular relevance; the claimed invention cannot be considered to involve an inventive step when the document is combined with one or more other such documents, such combination being obvious to a person skilled in the art "&" document member of the same patent family
Date of the actual completion of the international search 24 March, 2003 (24.03.03)		Date of mailing of the international search report 08 April, 2003 (08.04.03)
Name and mailing address of the ISA/ Japanese Patent Office		Authorized officer
Facsimile No.		Telephone No.

Form PCT/ISA/210 (second sheet) (July 1998)

INTERNATIONAL SEARCH REPORT

International application No.

PCT/JP03/02494

C (Continuation). DOCUMENTS CONSIDERED TO BE RELEVANT		
Category*	Citation of document, with indication, where appropriate, of the relevant passages	Relevant to claim No.
Y	Microfilm of the specification and drawings annexed to the request of Japanese Utility Model Application No. 52424/1984 (Laid-open No. 163019/1985) (Koizumi Apparel Co., Ltd.), 29 October, 1985 (29.10.85), (Family: none)	8
Y	JP 9-299109 A (Yugen Kaisha Tokai Takku), 25 November, 1997 (25.11.97), (Family: none)	9

Form PCT/ISA/210 (continuation of second sheet) (July 1998)