

(19)



Europäisches Patentamt
European Patent Office
Office européen des brevets



(11)

EP 1 505 236 B1

(12)

EUROPEAN PATENT SPECIFICATION

(45) Date of publication and mention
of the grant of the patent:
14.06.2006 Bulletin 2006/24

(51) Int Cl.:
E05D 7/10 (2006.01)

(21) Application number: **04380156.2**

(22) Date of filing: **21.07.2004**

(54) **Detachable hinge**

Losbares Scharnier

Charnière détachable

(84) Designated Contracting States:
**AT BE BG CH CY CZ DE DK EE ES FI FR GB GR
HU IE IT LI LU MC NL PL PT RO SE SI SK TR**

(30) Priority: **08.08.2003 ES 200301928**

(43) Date of publication of application:
09.02.2005 Bulletin 2005/06

(73) Proprietor: **Hispano Mecano Electrica S.A.
08786 Capellades (Barcelona) (ES)**

(72) Inventor: **Salvador Moreno, José
08786 Capellades (Barcelona) (ES)**

(74) Representative: **Durán Moya, Luis-Alfonso et al
DURAN-CORRETJER
Còrsega, 329
(Paseo de Gracia/Diagonal)
08037 Barcelona (ES)**

(56) References cited:
**DE-A- 4 010 466 DE-U- 8 701 805
GB-A- 360 677**

EP 1 505 236 B1

Note: Within nine months from the publication of the mention of the grant of the European patent, any person may give notice to the European Patent Office of opposition to the European patent granted. Notice of opposition shall be filed in a written reasoned statement. It shall not be deemed to have been filed until the opposition fee has been paid. (Art. 99(1) European Patent Convention).

Description

[0001] The present invention relates to a detachable hinge device arrangement for electrical control cabinets and the like, which has considerable advantages over that known in the field.

[0002] The object of the hinge device arrangement according to the present invention is to obtain articulated interconnecting components or hinge components between the door of a cabinet, in particular of an electrical control cabinet, and the body of the cabinet itself.

[0003] DE 8701805 discloses a device arrangement for general use, wherein the hinge device comprises a housing with a resilient tongue, operable from the outside through corresponding notches in the door and the housing, which triggers a spring which impedes a movable pin part. The mechanism is complicated and difficult to disassemble, as a tool is required to do it.

[0004] The hinge device of the arrangement object of the present invention is basically characterised in that it comprises, on the one hand, a single part produced by injection moulding of a material with properties of flexibility and resilience, for example a synthetic material, simultaneously having means for its positioning and centring in the door of the cabinet and retaining means formed by a resilient retaining strip. On the other hand, the hinge device is completed by a recess having a shape mating with that of the hinge device and disposed in the cabinet door.

[0005] In a specific embodiment the hinge device of the arrangement according to the present invention will comprise a lower centring shaft and an upper body, from which a resilient laminar part projects laterally and which has basically two positions, one position which is stable in itself or natural position which forms a specific angle, preferably acute, with the axis of the hinge device, and a second position in which said laminar piece may be forced to rock on its base and fit in a notch of mating shape in the body itself to allow displacement of said hinge device in the vertical direction to detach the door. Obviously said position also coincides with the assembly position. A recess having a shape mating with that of the hinge device and having, at the bottom, a recess for the cylindrical shaft and, at the top, a zone for receiving the resilient laminar component of the hinge device and an upper free zone allowing vertical displacement for assembly and disassembly of the hinge device in its position of use is produced in the door.

[0006] To assist understanding there follow, by way of descriptive but non-limiting example, some representative drawings of a preferred embodiment of the present invention.

Fig. 1 is a perspective view of a cabinet equipped with a door carrying the hinge device arrangement according to the present invention.

Fig. 2 is a perspective view on an enlarged scale of the individual hinge device arrangement.

Fig. 3 is a perspective view showing the first operation of introducing the hinge device into the mating recess of the door.

Fig. 4, 5 and 6 are respective elevations with a partial section showing the operating phase, the phase of disassembly of the hinge device, and the position in which the door is released from the cabinet.

[0007] The hinge device of the arrangement according to the present invention is intended for use in a cabinet 1 essentially formed by a parallelepiped shaped body with an open front face, in which is positioned a rebatable closing door 2 equipped with a conventional lock 3 and with the hinge device unit 4 according to the invention.

[0008] The hinge device unit 4 is composed of a hinge pin body based on two different parts, shown in the figures and in particular in Fig. 3, in which the hinge pin body, indicated in its entirety by reference numeral 5, has a lower shaft 6 or centring and turning axis for fitting in a mating opening 7 of a recess in the corner zone of the door 2, said recess being designated in its entirety by reference numeral 8. The hinge device 5 also has an upper body 9 for insertion into the interior of the hollow 8 and equipped with a tongue or laminar component with resilient properties 10 joined to the body 9 by its base 11. The laminar part or resilient tongue 10 has, at the top, an enlargement 12 for lining up inside a lateral notch 13 produced in one of the walls of the recess 8, and this represents the conventional operating position of the hinge device, as shown in Fig. 4, in which the tongue 10 impedes the backward movement of the hinge device 5 which, when the door 2 is connected to the lower part 14 of the cabinet body 1, Fig. 2 and 4 to 6, allows the conventional functions of the hinge to be carried out, and this obviously provides the advantage of great simplicity in construction and assembly.

[0009] The assembly, service and disassembly phases are shown in Fig. 3 to 6, Fig. 3 showing the introduction of the hinge device unit 5 into the interior of the recess 8, occupying the top part of said recess 8 which has a greater height than the hinge device 5, corresponding to the position shown in Fig. 6. In this position, the tongue 10 is adapted to the notch 15 in the body 5 which has a shape mating with that of the tongue 10, in other words a lower narrower zone to line up with the body of the tongue 10 and a deeper upper part, indicated by reference numeral 16, for insertion of the enlargement 12 of said tongue. In this position the hinge device will be introduced into the interior of the recess 8, then descend manually, as can be seen in Fig. 5, resulting in the normal operating position shown in Fig. 4. As illustrated, Fig. 5 and 6 also show the disassembly sequence which involves manual lateral flexion of the tongue 10 to release it from the recess 13, upward displacement, as indicated by the vector 17, and removal of the door with its hinge, as shown in Fig. 6.

[0010] The recess 8 of the door 2 comprises, in the proximity of the recess 13, a second recess of smaller

dimensions 18 for laterally receiving the enlargement 12 so that, in the assembly and disassembly position, the hinge device 5 can be retained to prevent its free displacement, as can be seen in Fig. 6.

[0011] The individual hinge device 5 also comprises a front wing 19 which allows easy fixing of the hinge stud for its upward and downward displacement during the assembly and disassembly operations.

[0012] As will be appreciated, the detachable hinge arrangement according to the invention may adopt different variations within the scope defined by the appended claims.

Claims

1. Detachable hinge device arrangement for doors of electrical control cabinets and the like, the hinge device (4) comprising a single pin and hinge body (5) equipped with a pivot (6) for coupling and centring in opposing orifices (7) of the door and cabinet thereof, and an upper body (9) with a resilient tongue (10) **characterised in that** the hinge device (4) is produced in single piece and that said resilient tongue (10) is capable of being introduced into a lateral notch (13) of a recess (8) of mating shape of the cabinet door (2), the hinge device (4) being secured to the cabinet door (2) when the resilient tongue (10) is introduced into a recess of mating shape of the cabinet door and allows easy assembly and disassembly thereof by pressing the resilient tongue (10) to liberate it from its retaining position in the notch (13) of the cabinet door.
2. Detachable hinge device arrangement for electrical control cabinets and the like according to claim 1, **characterised in that** the hinge device (4) is produced in a single piece injection-moulded from a flexible resilient material, the resilient tongue (10) comprising a stable position which forms an angle with the longitudinal axis of said hinge device.
3. Detachable hinge device arrangement for electrical control cabinets and the like according to claim 1, **characterised in that**, at the top, the tongue (10) comprises an enlargement (12) capable of being introduced, in the operating position, into a lateral notch (13) of the cabinet door recess (8) which receives the hinge pin.
4. Detachable hinge device arrangement for electrical control cabinets and the like according to claim 1, **characterised in that** the body (5) of the hinge device has a notch (15) with a shape mating, on one side, with that of the resilient tongue to allow it to be fitted in the assembly and disassembly phases of the hinge.

5. Detachable hinge device arrangement for electrical control cabinets and the like according to claim 1, **characterised in that** the recess (8) of the cabinet door, receiving the hinge device, has a greater height than the hinge, allowing assembly and disassembly thereof.
6. Electric control cabinet which presents at least one detachable hinge device arrangement according to anyone of claims 1 to 5.

Patentansprüche

1. Lösbare Scharniervorrichtungsanordnung für Türen von elektrischen Schaltschränken und ähnlichem, wobei die Scharniervorrichtung (4) einen einzelnen Zapfen- und Scharnierkörper (5) umfasst, der mit einem Gelenk (6) zum Verankern und Zentrieren in gegenüberliegenden Öffnungen (7) der Tür und dem dazugehörigen Gehäuse und mit einem oberen Körper (9) mit einer elastischen Zunge (10) ausgestattet ist, **dadurch gekennzeichnet, daß** die Scharniervorrichtung (4) aus einem Stück hergestellt ist und daß die elastische Zunge (10) in eine seitliche Einkerbung (13) einer passend ausgebildeten Aussparung (8) der Gehäusetür (2) eingeführt werden kann, wobei die Scharniervorrichtung (4) in der Gehäusetür (2) verriegelt ist, wenn die elastische Zunge (10) in eine passend ausgebildete Aussparung der Gehäusetür eingeführt ist, und ein einfaches Einbauen und Ausbauen derselben durch Pressen der elastischen Zunge (10) erlaubt, um diese aus ihrer eingenommenen Lage in der Einkerbung (13) der Gehäusetür zu befreien.
2. Lösbare Scharniervorrichtungsanordnung für Türen von elektrischen Schaltschränken und ähnlichem gemäß Anspruch 1, **dadurch gekennzeichnet, daß** die Scharniervorrichtung (4) aus einem flexiblen elastischen Material spritzgegossen in einem Stück hergestellt wird, wobei die elastische Zunge (10) eine stabile Position einnimmt, welche einen Winkel mit der Längsachse der Scharniervorrichtung bildet.
3. Lösbare Scharniervorrichtungsanordnung für Türen von elektrischen Schaltschränken und ähnlichem gemäß Anspruch 1, **dadurch gekennzeichnet, daß** die Zunge (10) im oberen Bereich eine Ausweitung (12) umfasst, die in Betriebsstellung in eine seitliche Einkerbung (13) der Aussparung (8) der Gehäusetür, die den Scharnierzapfen aufnimmt, eingeführt werden kann.
4. Lösbare Scharniervorrichtungsanordnung für Türen von elektrischen Schaltschränken und ähnlichem gemäß Anspruch 1, **dadurch gekennzeichnet, daß** der Körper (5) der Scharniervorrichtung eine Einkerbung

bung (15) besitzt, die einseitig mit der flexiblen Zunge zusammenpasst, um es dieser zu erlauben, in der Einbau- und Ausbauphase des Scharniers eingepasst zu werden.

5. Lösbare Scharniervorrichtungsanordnung für Türen von elektrischen Schaltschränken und ähnlichem gemäß Anspruch 1, **dadurch gekennzeichnet, daß** die Aussparung (8) der Gehäusetür, die die Scharniervorrichtung aufnimmt, eine größere Höhe besitzt als das Scharnier, was den Einbau und Ausbau derselben erlaubt.
6. Elektrischer Schaltschrank, welcher mindestens eine lösbare Scharniervorrichtungsanordnung gemäß einem der Ansprüche 1 bis 5 aufweist.

Revendications

1. Système de charnière détachable pour portes d'armoires de commande électrique et similaires, la charnière (4) comprenant un seul corps (5) formant axe et charnière équipé d'un pivot (6) pour le couplage et le centrage dans des orifices (7) opposés de sa porte et de son armoire et équipé en outre d'un corps supérieur (9) doté d'une languette élastique (10), **caractérisé en ce que** la charnière (4) est produite en une seule pièce et **en ce que** ladite languette élastique (10) est capable d'être introduite à l'intérieur d'une encoche latérale (13) d'un évidement (8) de la porte d'armoire (2) de forme correspondante, la charnière (4) étant fixée à la porte d'armoire (2) lorsque la languette élastique (10) est introduite à l'intérieur d'un évidement dont la forme s'accouple à celle de la porte d'armoire et permet d'assembler et de désassembler facilement celle-ci en pressant la languette élastique (10) pour la libérer de sa position de retenue dans l'encoche (13) de la porte d'armoire.
2. Système de charnière détachable pour armoires de commande électrique et similaires selon la revendication 1, **caractérisé en ce que** la charnière (4) est produite en une seule pièce moulée par injection à partir d'un matériau élastique flexible, la languette élastique (10) comprenant une position stable qui forme un angle avec l'axe longitudinal de ladite charnière.
3. Système de charnière détachable pour armoires de commande électrique et similaires selon la revendication 1, **caractérisé en ce que**, au niveau de la partie supérieure, la languette (10) comprend un élargissement (12) capable d'être introduit, dans la position de fonctionnement, à l'intérieur de l'encoche latérale (13) de l'évidement (8) de la porte d'armoire qui reçoit le corps (5) formant axe et charnière.

4. Système de charnière détachable pour armoires de commande électriques et similaires selon la revendication 1, **caractérisé en ce que** le corps (5) de la charnière (4) présente une encoche (15) dont la forme s'accouple, sur une face, avec celle de la languette élastique (10) pour permettre d'ajuster la languette dans ladite encoche au cours des phases d'assemblage et de désassemblage de la charnière.
5. Système de charnière détachable pour armoires de commande électrique et similaires selon la revendication 1, **caractérisé en ce que** l'évidement (8) de la porte d'armoire, recevant la charnière (4), est plus haut que la charnière, permettant d'assembler et de désassembler ladite charnière.
6. Armoire de commande électrique qui présente au moins un système de charnière détachable selon l'une quelconque des revendications 1 à 5.

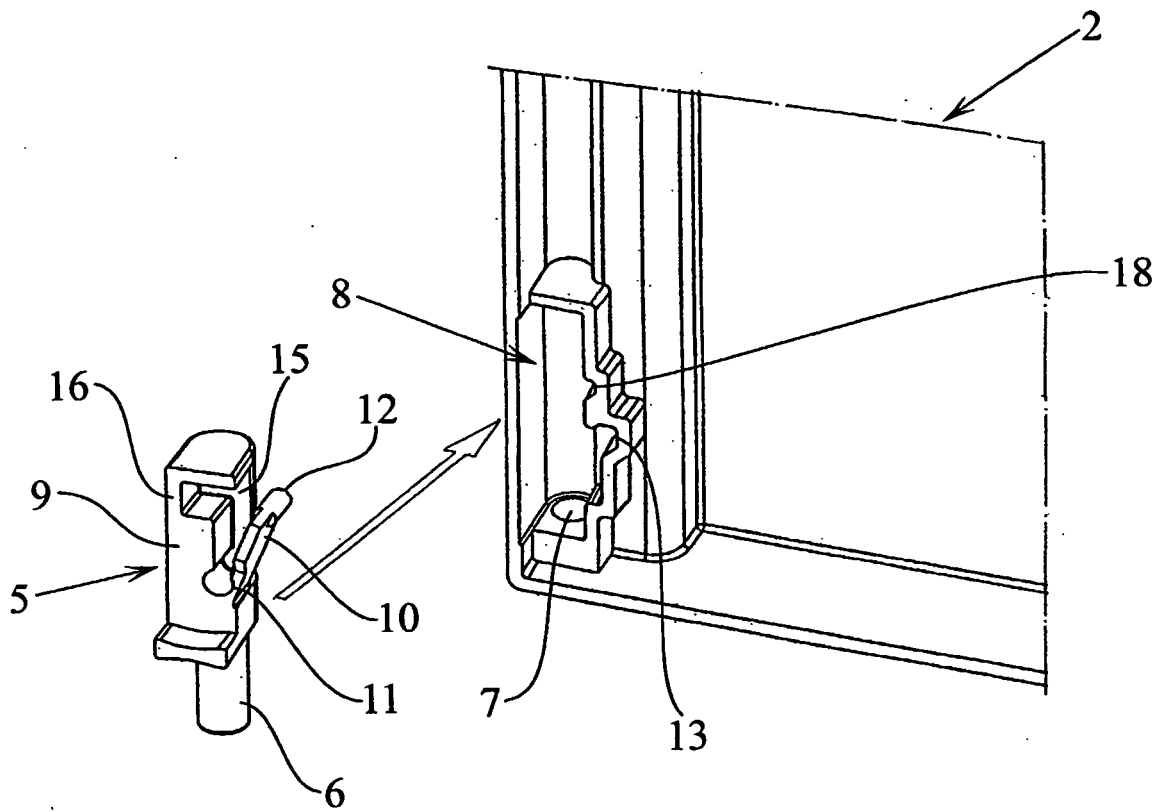

FIG. 3

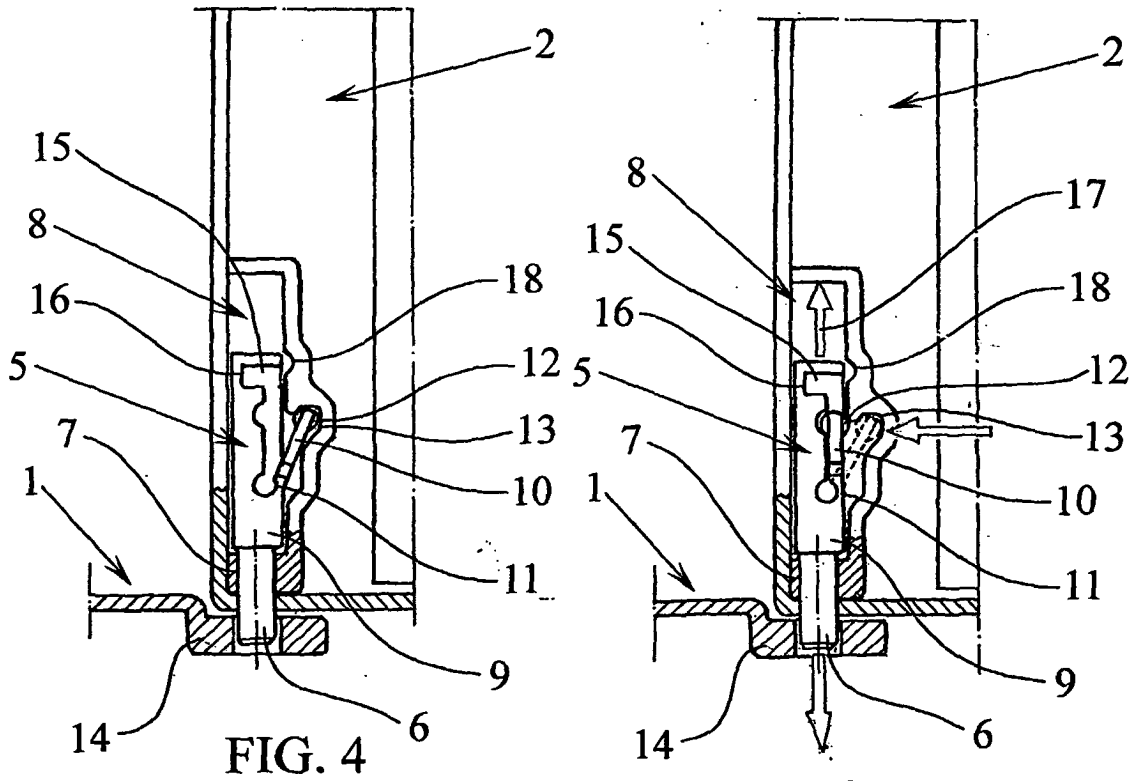

FIG. 5

FIG. 4

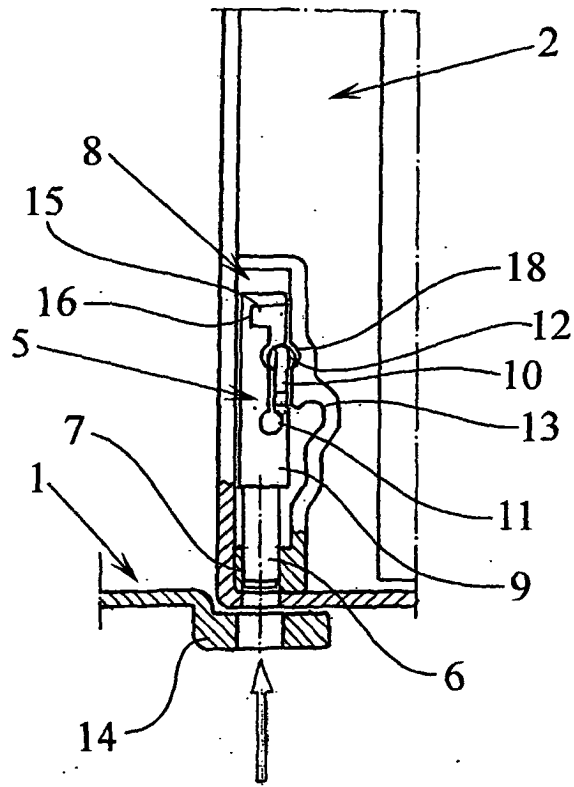

FIG. 6