



(11) **EP 1 510 853 B9**

(12) **CORRECTED EUROPEAN PATENT SPECIFICATION**

(15) Correction information:
Corrected version no 1 (W1 B1)
Corrections, see
Description Paragraph(s) 2, 4-6

(51) Int Cl.:
G02F 1/13357 (2006.01)

(48) Corrigendum issued on:
09.10.2013 Bulletin 2013/41

(45) Date of publication and mention
of the grant of the patent:
05.06.2013 Bulletin 2013/23

(21) Application number: **04090323.9**

(22) Date of filing: **21.08.2004**

(54) **Method of mounting liquid crystal display module**

Verfahren zur Montage eines Flüssigkristallanzeigemoduls

Méthode de montage d'un module d'affichage à cristaux liquides

(84) Designated Contracting States:
DE FR GB IT

(30) Priority: **27.08.2003 JP 2003302228**

(43) Date of publication of application:
02.03.2005 Bulletin 2005/09

(73) Proprietor: **NEC Corporation**
Minato-ku
Tokyo 108-8001 (JP)

(72) Inventor: **Ide, Katsuhisa**
Minato-ku
Tokyo 108-01 (JP)

(74) Representative: **Stork Bamberger**
Patentanwälte
Postfach 73 04 66
22124 Hamburg (DE)

(56) References cited:
EP-A- 1 310 820 WO-A-03/014816

- **PATENT ABSTRACTS OF JAPAN vol. 2002, no. 06, 4 June 2002 (2002-06-04) & JP 2002 055329 A (SONY CORP), 20 February 2002 (2002-02-20)**
- **PATENT ABSTRACTS OF JAPAN vol. 0174, no. 16 (P-1584), 3 August 1993 (1993-08-03) & JP 5 080334 A (ROHM CO LTD), 2 April 1993 (1993-04-02)**
- **PATENT ABSTRACTS OF JAPAN vol. 1999, no. 12, 29 October 1999 (1999-10-29) & JP 11 184392 A (SANYO ELECTRIC CO LTD; TOTTORI SANYO ELECTRIC CO LTD), 9 July 1999 (1999-07-09)**

EP 1 510 853 B9

Note: Within nine months of the publication of the mention of the grant of the European patent in the European Patent Bulletin, any person may give notice to the European Patent Office of opposition to that patent, in accordance with the Implementing Regulations. Notice of opposition shall not be deemed to have been filed until the opposition fee has been paid. (Art. 99(1) European Patent Convention).

Description

BACKGROUND OF THE INVENTION

FIELD OF THE INVENTION

[0001] The present invention relates to a liquid crystal display module, a mobile communication device using the same, and a method of mounting a liquid crystal display (hereinafter referred to as LCD) module to be used as a display section in the mobile communication device.

DESCRIPTION OF THE RELATED ART

[0002] Use of LCD-assemblies as display sections in mobile communication devices is conventionally known, e.g. from EP 1 310 820 A1.

[0003] A conventional LCD module 12 of a mobile communication device is assembled so that the LCD module 12 is sandwiched between an upper case 11a and a lower case 11b of the mobile communication device as shown in FIG. 1. With regard to a method of mounting the LCD module 12, the LCD module 12 is mounted in the cases 11 by fixing four corners of each of the cases 11a and 11b by screws 13a through 13d with the LCD module 12 sandwiched between the cases 11 (11a, 11b) as shown in FIG. 2.

[0004] An LCD-assembly where the LCD-module is sandwiched between two frames and thus attached to a backlight module is disclosed in JP 2002 055 329 A.

[0005] In order to protect such display panels from external shock, it is known to provide additional springing elements which are adapted to absorb the shock, e.g. from WO 03/014816 A.

[0006] Further, for miniaturization of a liquid crystal display unit, light emitting diodes are employed as illuminating devices, e.g. in EP 1 158 347. For the same purpose, technologies of decreasing the width of a peripheral edge portion (frame portion) which surrounds the liquid crystal display section, i.e., so-called frame-narrowing technologies have been proposed. For the purpose of such frame narrowing technologies, the following method of mounting an LCD module to a case has been proposed (e.g. Japanese Patent Laid-Open Publication No. Hei 11-184392). Namely, U-shaped brackets are placed so that their central main portions overlap both the right and left sides of the LCD module, and then the U-shaped brackets are attached to the LCD module by fixing the bended portions at both ends of the U-shaped brackets to the upper and lower sides of the LCD module by screws. The LCD module is then mounted to the case of the liquid crystal display unit by fixing the case to the U-shaped brackets through screws holes provided in the main portions of the U-shaped brackets.

[0007] However, according to a conventional method of mounting an LCD module, the LCD module comprises an LCD, an optical waveguide, a backlight module including a light emitting diode (hereinafter referred to as

LED), and a main substrate. In this configuration, when a larger LCD screen and increased functions of a mobile communication device are demanded, an increase in the number of parts to be mounted in the liquid crystal display unit tends to cause the problem of having difficulty in mounting the LCD module in the mobile communication device.

[0008] On the other hand, according to the method described in the above-mentioned Japanese Patent Laid-Open Publication No. Hei 11-184392, the U-shaped brackets are used to fix the LCD module to the case, and therefore a space for setting the U-shaped brackets is needed. For this reason, the above-mentioned method does not provide a satisfactory solution to the problem of having difficulty in mounting the LCD module in the mobile communication device, as well as it has limitations in the frame narrowing.

SUMMARY OF THE INVENTION

[0009] It is therefore an object of the present invention to provide a method of mounting a liquid crystal display module, which can secure a space for packaging any other functions, achieve a frame-narrowing, and miniaturize a liquid crystal display unit, without the need for any special attaching parts.

[0010] A method of mounting a liquid crystal display module according to the present invention comprises the steps of: housing the liquid crystal display in a backlight module which includes a light emitting diode serving as a light source of a backlight for the liquid crystal display to constitute a liquid crystal display module; and fixing the liquid crystal display module to a case by a fixing member through a fixing section provided on a side face of the backlight module.

[0011] The fixing member is, for example, a screw which can be removed from the case and/or a wedge which cannot be removed from the case.

[0012] The case is, for example, a case for a mobile communication device.

[0013] Alternatively, the case is, for example, a first case of a mobile communication device which includes the first case and a second case rotatably connected to the first case.

[0014] Further, the fixing member is, for example, a screw which can be removed from the case and/or a wedge which cannot be removed from the case.

[0015] In a conventional LCD module as a display section of a mobile communication device, a space for mounting by fastening screws provided on the outside of the LCD module and a space for setting special attaching parts such as a U-shaped bracket, in a plan view, are necessary. According to the present invention, the liquid crystal display module is fixed to the case through the fixing section provided on the side face of the backlight module. Consequently, such conventionally required spaces become unnecessary. Therefore, it is possible to secure a space for packaging any other functions, to nar-

row the frame, and to miniaturize the entire device without the need for any special attaching parts, thereby permitting improvement in the functionality.

BRIEF DESCRIPTION OF THE DRAWINGS

[0016]

FIG. 1 is a perspective view showing an example of mounting of a conventional LCD module to a case; FIG. 2 is a plan view showing an example of mounting of a conventional LCD module to a case; FIG. 3 is a perspective view showing an assembled condition of an LCD module according to an embodiment of the present invention; FIG. 4 is a perspective view of the LCD module according to the embodiment of the present invention; FIG. 5 is a plan view showing an example of mounting of the LCD module to a case according to the embodiment of the present invention; FIG. 6 is a perspective view showing an example of mounting of the LCD module to the case according to the embodiment of the present invention; and FIG. 7 is a plan view showing a mounted condition of the LCD module to the case according to the embodiment of the present invention.

DETAILED DESCRIPTION OF THE PREFERRED EMBODIMENT

[0017] Preferred embodiments of the present invention will now be described with reference to the accompanying drawings. FIG. 3 is a perspective view showing an assembled condition of an LCD module 1 according to an embodiment of the present invention. FIG. 4 is a perspective view of the LCD module 1 of the embodiment. FIG. 5 is a plan view of the LCD module 1 of the embodiment. FIG. 6 is a schematic diagram illustrating a force to be applied to the LCD module 1. The LCD module 1 is used, for example, as a display section of a foldable cellular phone or the like constructed by rotatably connecting two cases together.

[0018] The LCD module 1 principally comprises an LCD 1a, a backlight module 1b provided with an LED section 1c, an optical waveguide (not shown), and a light reflector (not shown). The LCD 1a, the optical waveguide, and the light reflector or the like are housed in the backlight module 1b. The LCD 1a has a non-display section along its peripheral edge portion and the area excluding this non-display section is an LCD display section 1f.

[0019] The side faces of the backlight module 1b are provided with fixing sections 1d, 1e, 1g, and 1h to mount and fix the LCD module 1 to a case (not shown). An LED (not shown) of the LED section 1c mounted in the backlight module 1b is a light source of a backlight for the LCD 1a.

[0020] As shown in FIG. 5, the LCD module 1 is fixed to a case 2 by screws 3(3a through 3d) at the fixing sec-

tions 1d, 1e, 1g, and 1h provided on the side faces of the backlight module 1b.

[0021] In this case, since the LCD display section 1f has a smaller outward form than the LCD 1a, the LCD module 1 is fixed to the case 2 using the fixing sections 1d, 1e, 1g, and 1h on the side faces of the backlight module 1b so as not to affect the LCD display section 1f.

[0022] More specifically, in accordance with the present embodiment, the LCD module 1 is fixed, using the side faces of the LCD module 1, to the case 2 from the side faces by screws 3 (3a through 3b), as shown in FIG. 6. As a member to fix the LCD module 1, screws which can be removed from the case 2 or wedges which cannot be removed from the case 2 may be used, or these two types may be combined.

[0023] This feature of the present embodiment eliminates the need for the space, in a plan view, for fixing the LCD module 1 at four places on its outside using screws 13a through 13d, which space is required in the conventional liquid crystal display shown in FIG. 2, thereby making it possible to miniaturize the liquid crystal display, as well as the mobile communication device itself. If the mobile communication device is not designed to be reduced in size, the space required for fixing by the fastening screws 13a through 13d can be used for other parts, and consequently the functionality of the mobile communication device can be improved without changing its size.

[0024] FIG. 7 is a plan view showing a mounted condition of the LCD module 1 shown in FIG. 3 to a case. FIG. 7 illustrates a positional relationship between the LED area 1c and the LCD display section 1f, and the case 2. Between the LCD display section 1f and the case 2, there is an area 4 which is irrelevant to display and which begins from both sides of the case 2.

[0025] The area 4 which is irrelevant to display is used chiefly for bonding an optical waveguide and for mounting liquid crystal driving parts for the LCD 1a and is irrelevant to the displaying of the LCD 1a. The irrelevant-to-display area 4 is used as areas 5a through 5d for fixing by the fastening screws 3a through 3d, from the side faces. In addition, the LCD module 1 may have any other circuit boards integrally mounted.

[0026] As described above, with the present embodiment, the LCD module 1 is fixed to the case 2 by the fastening screws 3a and 3b at the fixing areas 1d, 1e, 1g, and 1h on the side faces of the backlight module 1b. Consequently, the space for fixing by the fastening screws 13a through 13d on the outside of the conventional LCD module 12 as shown in Fig. 2 becomes unnecessary, and it is thus possible to package any other functions in that space and to miniaturize the device. Therefore, the present embodiment enables a space for packaging any other functions to be secured, the frame to be narrowed, and the device to be miniaturized without the need for any special attaching parts.

Claims

1. A method of mounting a liquid crystal display module comprising the steps of:

housing a liquid crystal display (1a) in a backlight module (1b) which includes a light emitting diode (1c) serving as a light source of a backlight for the liquid crystal display (1a) to constitute a liquid crystal display module (1); and fixing said liquid crystal display module (1) to a case (2) by a fixing member (3) through a fixing section provided on a side face of the backlight module(1b).

2. The method of mounting a liquid crystal display according to claim 1, **characterized in that** the case (2) is a case for a mobile communication device.
3. The method of mounting a liquid crystal display according to claim 1, **characterized in that** the case (2) is a first case of a mobile communication device which includes the first case and a second case rotatably connected to the first case.
4. The method of mounting a liquid crystal display module according to any one of claims 1 to 3, **characterized in that** the fixing member (3) is a screw which can be removed from the case and/or a wedge which cannot be removed from the case.

Patentansprüche

1. Verfahren zur Montage eines Flüssigkristallanzeigemoduls, umfassend folgende Schritte:

Unterbringen einer Flüssigkristallanzeige (1a) in einem Hintergrundbeleuchtungsmodul (1b), das eine lichtemittierende Diode (1c) umfasst, die als Lichtquelle einer Hintergrundbeleuchtung für die Flüssigkristallanzeige (1a) dient, um ein Flüssigkristallanzeigemodul (1) zu bilden; und Befestigen des Flüssigkristallanzeigemoduls (1) mittels eines Befestigungselements (3) an einem Gehäuse (2) durch einen Befestigungsabschnitt, der an einer Seitenfläche des Hintergrundbeleuchtungsmoduls vorgesehen ist.

2. Verfahren zur Montage einer Flüssigkristallanzeige nach Anspruch 1, **dadurch gekennzeichnet, dass** das Gehäuse (2) ein Gehäuse für eine Mobilkommunikationseinrichtung ist.
3. Verfahren zur Montage einer Flüssigkristallanzeige nach Anspruch 1, **dadurch gekennzeichnet, dass** das Gehäuse (2) ein erstes Gehäuse einer Mobil-

kommunikationseinrichtung ist, die das erste Gehäuse und ein drehbar mit dem ersten Gehäuse verbundenes zweites Gehäuse umfasst.

4. Verfahren zur Montage eines Flüssigkristallanzeigemoduls nach einem der Ansprüche 1 bis 3, **dadurch gekennzeichnet, dass** das Befestigungselement (3) eine Schraube, die aus dem Gehäuse entfernt werden kann, und/oder ein Keil, der nicht aus dem Gehäuse entfernt werden kann, ist.

Revendications

1. Procédé de montage d'un module d'affichage à cristaux liquides comprenant les étapes consistant à:

loger un écran à cristaux liquides (1a) dans un module de rétroéclairage (1b) qui comprend une diode électroluminescente (1c) servant de source de lumière d'un rétroéclairage pour l'écran à cristaux liquides (1a) afin de constituer un module d'affichage à cristaux liquide (1); et fixer ledit module d'affichage à cristaux liquides (1) sur un boîtier (2) par un élément de fixation (3) par une section de fixation prévue sur une face latérale du module de rétroéclairage (1b).

2. Procédé de montage d'un écran à cristaux liquide selon la revendication 1, **caractérisé en ce que** le boîtier (2) est un boîtier pour un dispositif de communication mobile.

3. Procédé de montage d'un écran à cristaux liquide selon la revendication 1, **caractérisé en ce que** le boîtier (2) est un premier boîtier d'un dispositif de communication mobile qui comprend le premier boîtier et un second boîtier raccordé de manière rotative au premier boîtier.

4. Procédé de montage d'un module d'affichage à cristaux liquides selon l'une quelconque des revendications 1 à 3, **caractérisé en ce que** l'élément de fixation (3) est une vis qui peut être retirée du boîtier et/ou une cale qui ne peut pas être retirée du boîtier.

FIG. 1

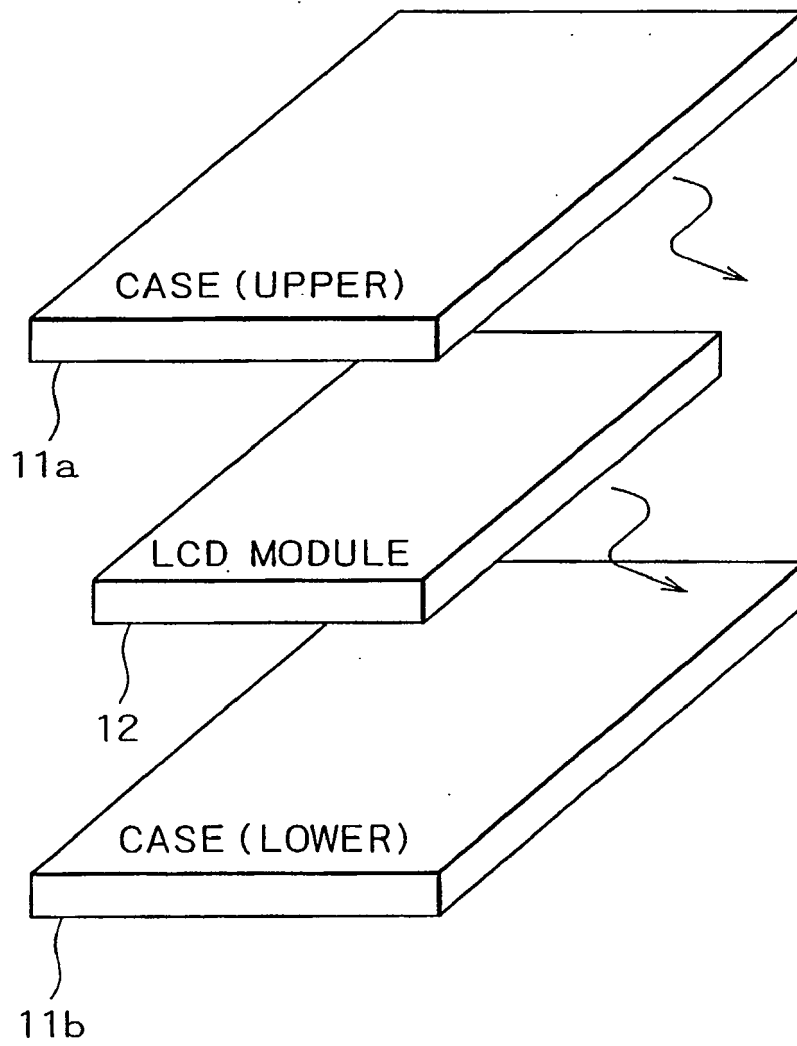

FIG. 2

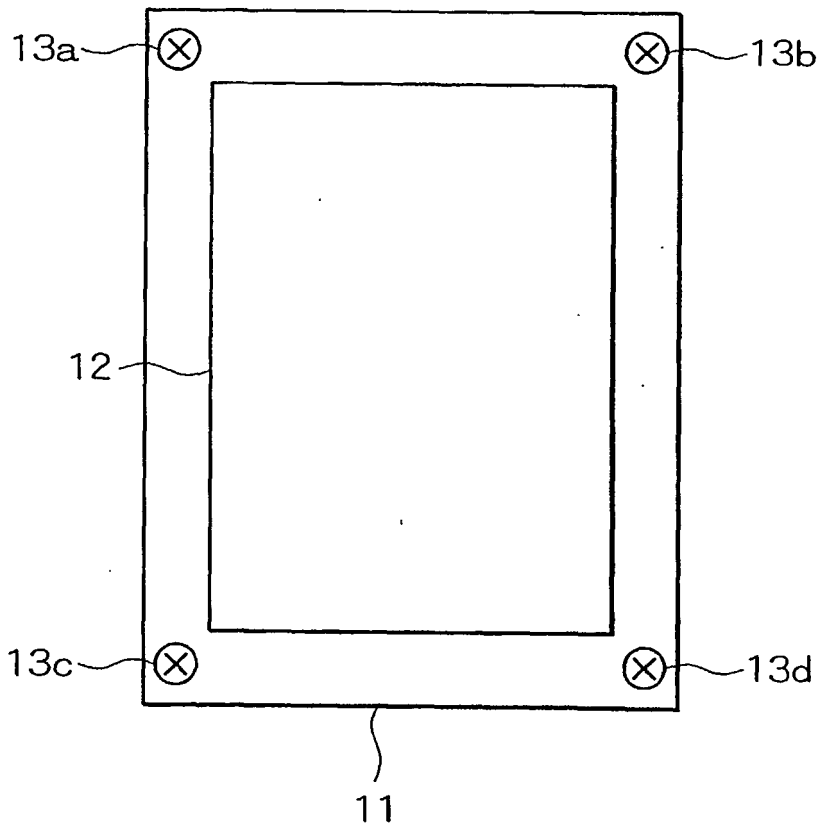

FIG. 3

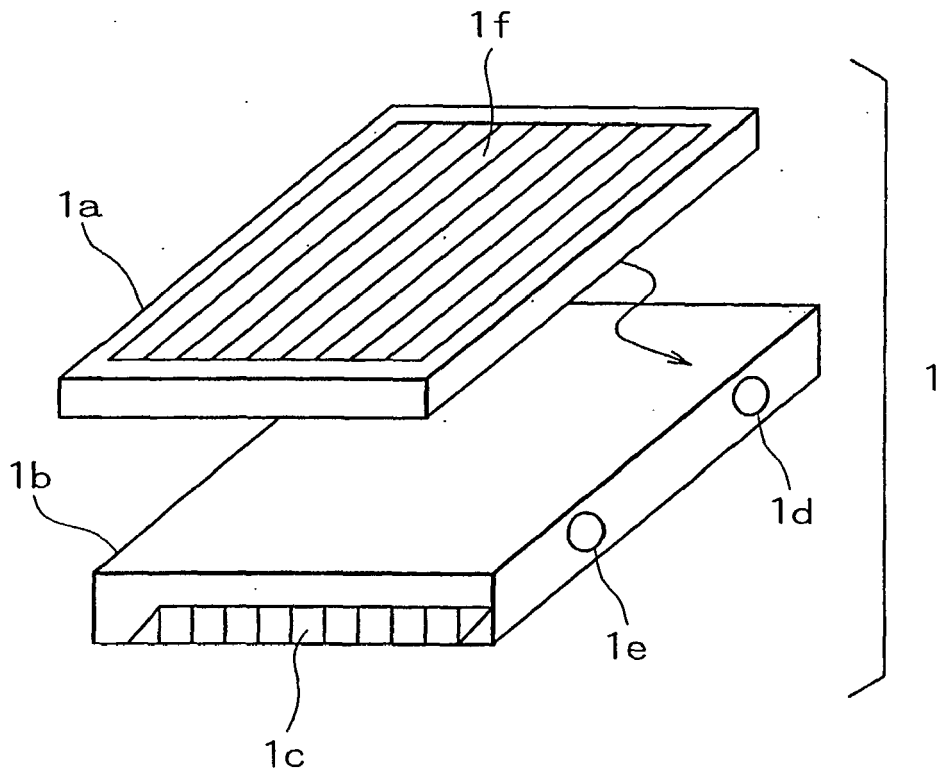

FIG. 4

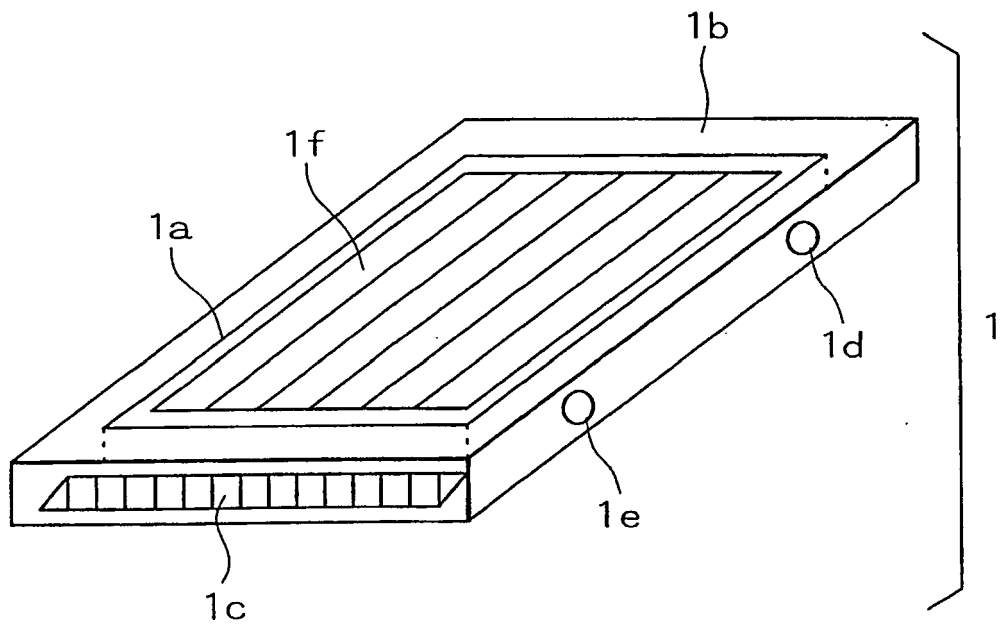

FIG. 5

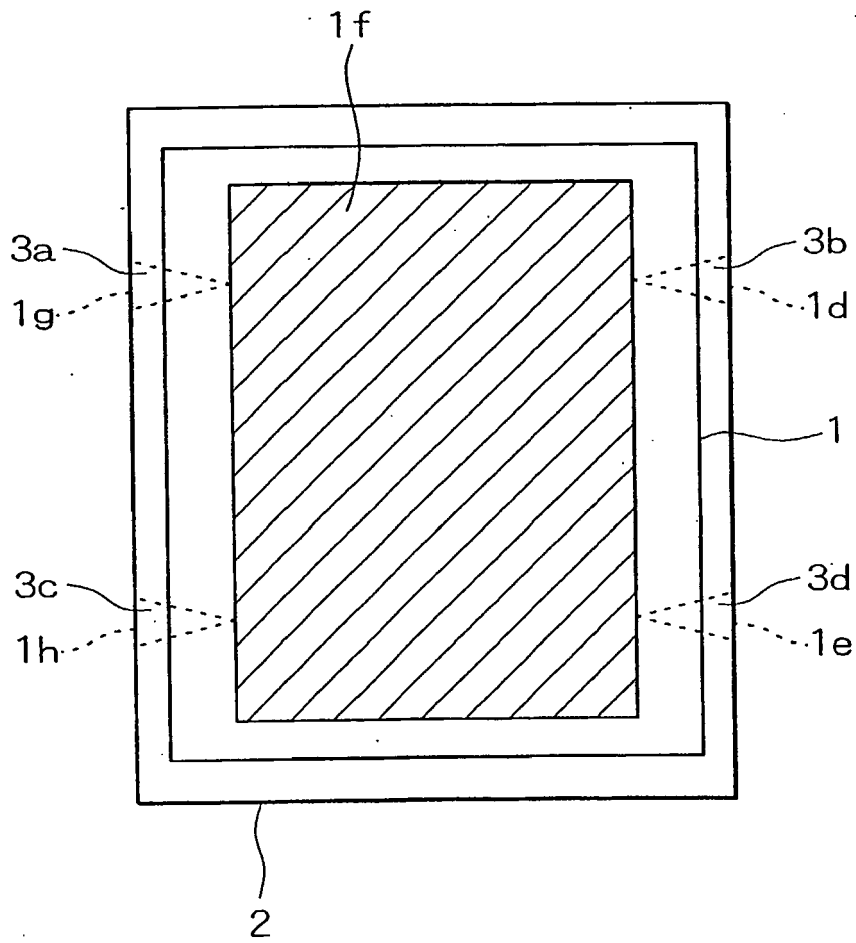

FIG. 6

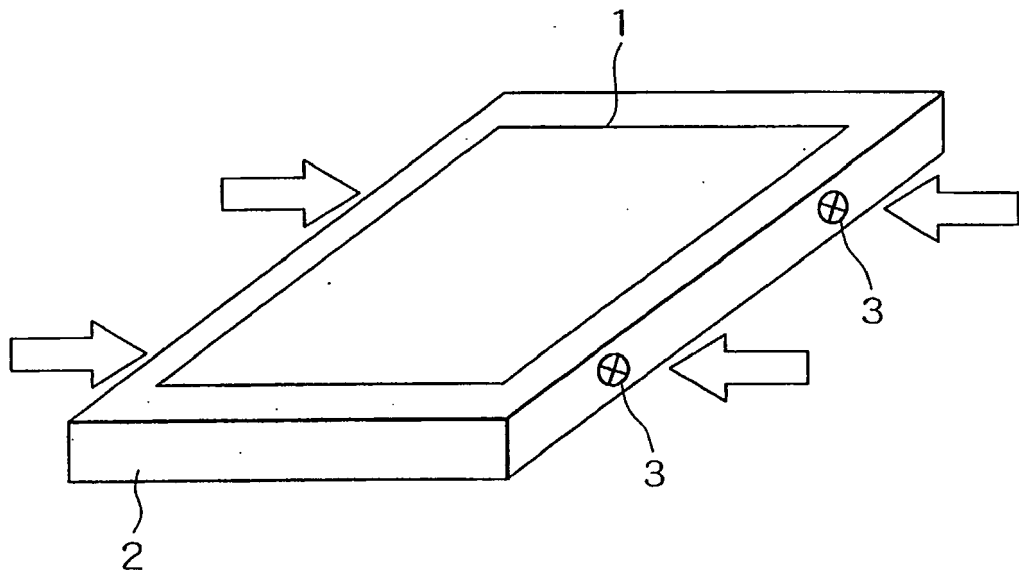
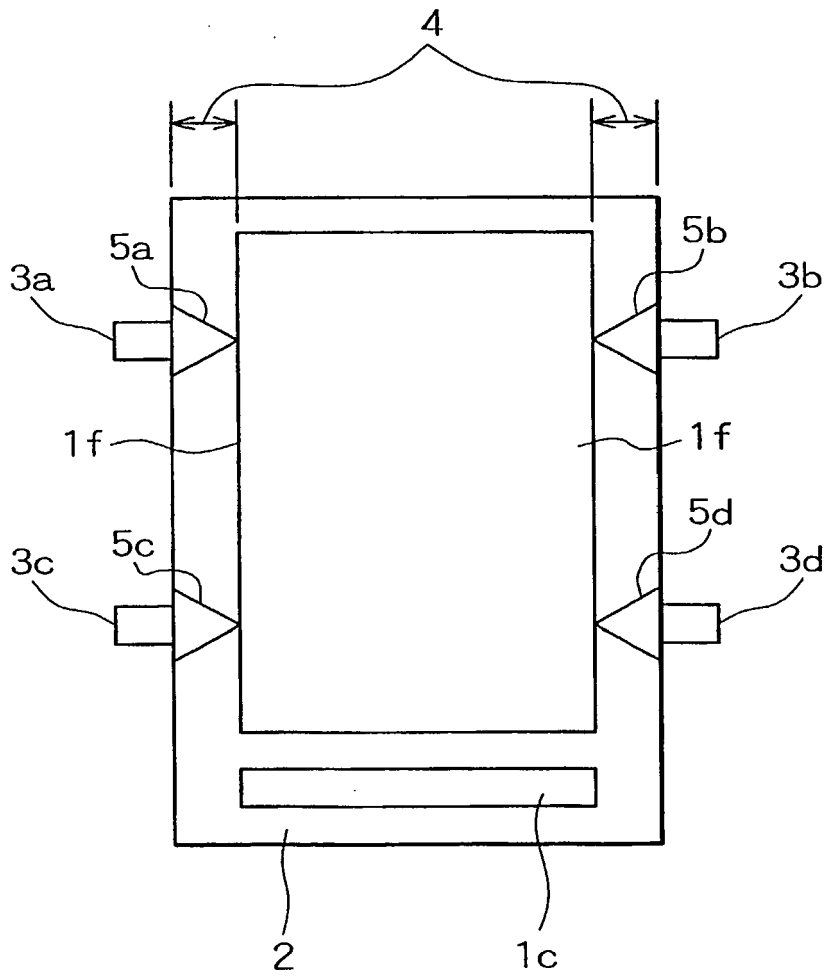

FIG. 7



REFERENCES CITED IN THE DESCRIPTION

This list of references cited by the applicant is for the reader's convenience only. It does not form part of the European patent document. Even though great care has been taken in compiling the references, errors or omissions cannot be excluded and the EPO disclaims all liability in this regard.

Patent documents cited in the description

- EP 1310820 A1 [0002]
- JP 2002055329 A [0004]
- WO 03014816 A [0005]
- EP 1158347 A [0006]
- JP HEI11184392 B [0006] [0008]