

(19)



Europäisches Patentamt
European Patent Office
Office européen des brevets



(11)

EP 1 519 006 B1

(12)

EUROPEAN PATENT SPECIFICATION

(45) Date of publication and mention
of the grant of the patent:
20.12.2006 Bulletin 2006/51

(51) Int Cl.:
F01B 3/00 ^(2006.01) **F04B 1/20** ^(2006.01)
F04B 1/22 ^(2006.01)

(21) Application number: **04023085.6**

(22) Date of filing: **28.09.2004**

(54) **Swash plate type hydraulic pump or motor**

Schrägscheiben-Pumpe oder -Motor

Pompe ou moteur avec plateau en bias

(84) Designated Contracting States:
DE FR

(30) Priority: **29.09.2003 JP 2003338588**

(43) Date of publication of application:
30.03.2005 Bulletin 2005/13

(73) Proprietor: **KAYABA INDUSTRY CO., LTD.**
Minato-ku,
Tokyo 105-6190 (JP)

(72) Inventor: **Shimizu, Takeo,**
c/o Kayaba Industry Co., Ltd.
Minato-ku
Tokyo 105-6190 (JP)

(74) Representative: **Schuster, Thomas**
Grünecker, Kinkeldey, Stockmair &
Schwanhäusser
Anwaltssozietät
Maximilianstrasse 58
80538 München (DE)

(56) References cited:
DE-A- 2 609 185 **DE-C- 823 828**
DE-C- 952 150 **GB-A- 709 183**
US-A- 2 229 715 **US-A- 2 741 188**

EP 1 519 006 B1

Note: Within nine months from the publication of the mention of the grant of the European patent, any person may give notice to the European Patent Office of opposition to the European patent granted. Notice of opposition shall be filed in a written reasoned statement. It shall not be deemed to have been filed until the opposition fee has been paid. (Art. 99(1) European Patent Convention).

Description

FIELD OF THE INVENTION

[0001] This invention relates to a swash plate type hydraulic pump or motor capable of being applied to hydrostatic transmission (hereinafter called HST), which is used in a running gear or the like in agricultural machinery, industrial vehicles, and construction machinery according to the preamble of claim 1.

BACKGROUND OF THE INVENTION

[0002] HST is a combination of a hydraulic pump and a hydraulic motor. Consequently, by changing the tilt angle of a swash plate in the hydraulic pump, and by changing the discharge amount in a range from zero to a maximum discharge amount, the rotational velocity of the hydraulic motor changes. A vehicle can thus continuously change speeds from a stopped state to a maximum forward or reverse speed.

[0003] Structures that comprise a single swash plate, a cylinder block, and a plurality of pistons that are housed on only one side of the cylinder block are often used as HST hydraulic pumps or hydraulic motors.

[0004] However, the size of the HST hydraulic pump or the hydraulic motor becomes large when a high volume is needed in the HST hydraulic pump or the hydraulic motor, respectively. In this case, a large space for mounting the HST to a vehicle is required, and this is detrimental to efficiency and cost.

[0005] An opposing type swash plate hydraulic pump or motor possessing not one swash plate, but instead a pair of swash plates, has been proposed in JP 50-115304 A as a way to make it possible to reduce the size of a hydraulic pump or a hydraulic motor.

[0006] Furthermore, DE 2609185 A1 reveals a swash plate type hydraulic pump or motor according to the preamble of claim 1.

SUMMARY OF THE INVENTION

[0007] The opposing type swash plate hydraulic pump or motor has a swash plate disposed on both sides of a cylinder block. A plurality of pistons are housed in the cylinder block from both sides thereof, and the pistons stroke according to the tilt angle of each of the swash plates.

[0008] In this case the number of pistons can be increased even if the cylinder block is not made larger in size. Accordingly, the volume of cylinder block can increase when used as a hydraulic pump or a hydraulic motor.

[0009] However, a hydraulic fluid passage and a valve mechanism that switches flow of the hydraulic fluid in order to supply and discharge the hydraulic fluid to and from the pistons disposed on both sides of the cylinder block become complex. Further, the hydraulic fluid pas-

sage becomes complex, and the supply and discharge efficiency for the hydraulic fluid worsens.

[0010] It is an object of this invention to provide a swash plate hydraulic pump or motor in which a valve mechanism for switching the flow of hydraulic fluid and a passage configuration are simplified.

[0011] According to the present invention, the above and other objects are achieved by a swash plate type hydraulic pump or motor pursuant to claim 1. Preferred embodiments are laid-down in the further subclaims.

BRIEF DESCRIPTION OF THE DRAWINGS

[0012] In the following, the present invention is explained in greater detail by means of embodiments thereof in conjunction with the accompanying drawings wherein:

FIG. 1 is a cross sectional view of a piston motor that shows an embodiment of this invention.

FIG. 2A is a left front surface view of a port block, FIG. 2B is a right front surface view of the port block, and FIG. 2C is a cross sectional view of the port block along a line segment D-D.

FIG. 3A is a cross sectional view of a cylinder block along a line segment H-H, and FIG. 3B is a longitudinal cross sectional view of the cylinder block.

FIG. 4A is a side view of a bushing, FIG. 4B is a cross sectional view of the bushing along a line segment F-F, and FIG. 4C is a cross sectional view of the bushing along a line segment G-G.

FIG. 5A is a side surface view of a valve body, FIG. 5B is a cross sectional view of the valve body along a line segment E-E, FIG. 5C is a left front surface view of the valve body, FIG. 5D is a cross sectional view of the valve body along a line segment B-B, and FIG. 5E is a cross sectional view of the valve body along a line segment C-C.

DETAILED DESCRIPTION OF THE PREFERRED EMBODIMENTS

[0013] Embodiments of this invention applied to a hydraulic motor of an HST installed in an industrial vehicle or the like will be explained below based on the appended drawings.

[0014] Referring to FIG. 1, a hydraulic motor 1 comprises a cylindrical case 25 and a port block 50 that is connected to the case 25. The hydraulic motor 1 is a swash plate type hydraulic pump or motor. A housing chamber 24 is provided in inner portions of the cylindrical case 25 and the port block 50. A cylinder block 4, a first swash plate 30, and a second swash plate 40 are housed in the housing chamber 24.

[0015] The cylinder block 4 is joined on an axis of a shaft 5 that is disposed in a center portion of the case 25, and the shaft 5 and the cylinder block 4 rotate integrally.

[0016] Consequently, a distal end portion of the shaft 5 is connected to an inner circumference of the cylinder block 4, through a spline 29. The shaft 5 is supported by the case 25, through a bearing 28, in an area where it passes through the case 25. The shaft 5 goes through a side wall of the case 25 and projects out to an outside portion. A final reduction gear, a differential gear, and the like (not shown) are connected to the shaft 5, and rotation of the shaft 5 is transmitted to wheels on the left and right sides of the vehicle.

[0017] On the other hand, an outer circumferential surface of the cylinder block 4 is supported by two bearings 26 and 27, and is supported so as to be free to rotate with respect to an inner circumference of the case 25. A rotational member comprising the cylinder block 4 and the shaft 5 is therefore supported through the three bearings 26, 27, and 28 with respect to the case 25.

[0018] A first cylinder bore 6 and a second cylinder bore 7 are formed in the cylinder block 4 so as to open on both sides of the cylinder block 4. The first cylinder bore 6 and the second cylinder bore 7 are disposed coaxially and communicate with each other. A plurality of the first cylinder bores 6 and the second cylinder bores 7 are disposed having fixed gaps on a pitch circle PC centered about a rotation axis of the cylinder block 4.

[0019] A first piston 8 and a second piston 9 are inserted into the first cylinder bore 6 and the second cylinder bore 7, respectively, in opposite directions, forming a volume chamber 10 therebetween. One end of the first piston 8 and one end of the second piston 9 project out from both end surfaces of the cylinder block 4. A distal end portion of the first piston 8 and a distal end portion of the second piston 9 are supported by shoes 21 and 22 that contact the first swash plate 30 and the second swash plate 40, respectively.

[0020] As discussed hereinafter, when hydraulic fluid is supplied to the volume chamber 10, the first piston 8 and the second piston 9 extend while contacting the first swash plate 30 and the second swash plate 40, respectively. When a rotational force is generated on the cylinder block 4 and the first piston 8 and the second piston 9 move in a retracting direction, hydraulic fluid discharges from the volume chamber 10, and the cylinder block 4 thus rotates in the same direction.

[0021] In order to maintain the contact between the shoes 21 and 22 and the first swash plate 30 and the second swash plate 40, respectively, the shoe 21 and the shoe 22 each comprise a ring shape retainer plate 75, a retainer holder 73 that contacts an inner circumferential portion of the retainer plate 75, and a plurality of center springs 74 that are disposed between the retainer holder 73 and the cylinder block 4.

[0022] A tilt angle of the first swash plate 30 and a tilt angle of the second swash plate 40 can be freely changed with respect to the shaft center of the cylinder block 4 so that the effective capacity volume of the hydraulic motor 1 is made variable. A portion of a rear surface 31 of the first swash plate 30, and a portion of a rear surface 41

of the second swash plate 40 are consequently formed having circular shapes, and are supported by a first swash plate bearing 32 and a second swash plate bearing 42, respectively, so as to be free to tilt.

[0023] A rod shape valve body 60 that can freely rotate relative to a through hole 12 formed in the center of the cylinder block 4 is inserted into each of the volume chambers 10 as a valve mechanism for supplying and discharging hydraulic fluid. The valve body 60 is fixed to the port block 50.

[0024] Referring to FIGs. 2A, 2B, and 2C, a support hole 55 into which the valve body 60 is inserted is formed in the port block 50. The support hole 55 possesses a gap with respect to an outer circumferential surface of the valve body 60, and three seal rings 56 are disposed between the support hole 55 and the valve body 60 (shown in FIG. 1). Three annular grooves 57 are formed side by side in an inner circumferential surface of the support hole 55, and each of the annular grooves 57 holds one of the seal rings 56.

[0025] Referring to FIG. 1, two pins 58 are disposed between the port block 50 and the valve body 60. The pins 58 stop the port block 50 and the valve body 60 from moving relative to one another. The pins 58 are inserted with a gap between the port block 50 and the valve body 60.

[0026] The support hole 55 elastically supports the valve body 60 through the seal rings 56. Further, the valve body 60 fits together with an inner circumferential surface of the cylinder block 4, through a bushing 70 that is disposed midway between the seal rings 56 (shown in FIG. 3 and FIG. 4). The concentric precision of the valve body 60 with respect to the cylinder block 4 is thus ensured.

[0027] When the gap between the valve body 60 and the bushing 70 becomes smaller due to fabrication errors or the like, seal dimensional error is absorbed by elastic deformation of the seal rings 56 because the valve body 60 is supported by the cylinder block 4 through the seal rings 56. The valve body 60 is not strongly pressed against the bushing 70, and thus does not lead to an increase in wear.

[0028] Referring to FIG. 2C, a pair of entrance and exit openings 51 are formed in the port block 50. The entrance and exit openings 51 are connected to a low pressure side and a high pressure side of a hydraulic fluid source, respectively, through pipes (not shown). High pressure hydraulic fluid is therefore sent in from one of the entrance and exit openings 51, and low pressure hydraulic fluid is discharged through the other entrance and exit opening 51.

[0029] Referring to FIGs. 5A, 5B, 5C, and 5D, two annular grooves 62 and 63 are formed in an outer circumferential surface of the valve body 60 that faces the port block 50. The annular grooves 62 and 63 are positioned between the seal rings 56 (shown in FIG. 1), and communicate with the respective entrance and exit openings 51 (shown in FIGs. 2A, 2B, and 2C) of the port block 50.

[0030] In contrast, a pair of supply and discharge ports

61 are formed having a circular arc shape in an outer circumferential surface of the valve body 60 that faces the inner circumferential surface of the cylinder block 4. The supply and discharge ports 61 are disposed symmetrically in an outer circumference of the valve body 60.

[0031] Through holes 64 and 65 that extend through an inner portion of the valve body 60 are formed in parallel with one another. One end of the through hole 64 communicates with the annular groove 62, and the other end of the through hole 64 communicates with one of the supply and discharge ports 61. Similarly, one end of the through hole 65 is connected to the annular groove 62, and the other end of the through hole 65 communicates with the other supply and discharge port 61.

[0032] Further, referring to FIG. 1 and FIG. 3, cylinder ports 11 connect the volume chambers 10 of the cylinder bores 6 and 7, which are formed in the cylinder block 4, to the through hole 12 of the inner circumference of the cylinder block 4. The cylinder ports 11 are disposed radially in positions opposite to the pair of supply and discharge ports 61 that are opened in the outer circumferential surface of the valve body 60.

[0033] The cylinder ports 11 therefore communicate in succession with the pair of supply and discharge ports 61 of the valve body 60 according to rotation of the cylinder block 4.

[0034] Hydraulic fluid guided from the hydraulic fluid source is therefore supplied to each of the volume chambers 10 through one of the entrance and exit openings 51 of the port block 50 (shown in FIG. 2), the annular groove 62 of the valve body 60, the through hole 64, one of the supply and discharge ports 61, and each of the cylinder ports 11 of the cylinder block 4 (shown in FIG. 1), for example. At this point, the hydraulic fluid that flows out from each of the volume chambers 10 according to rotation of the cylinder block 4 is discharged to a tank through each of the cylinder ports 11 of the cylinder block 4, the other supply and discharge port 61, the through hole 65 of the valve body 60, the annular groove 63, and the other entrance and exit opening 51 of the port block 50. The first piston 8 and the second piston 9 thus operate reciprocally within the first cylinder bore 6 and the second cylinder bore 7, respectively, causing the cylinder block 4 to rotate.

[0035] In other words, the first piston 8 and the second piston 9 extend out according to the tilt angle of the first swash plate 30 and the second swash plate 40, respectively, while connected to the high pressure side supply and discharge port 61. The cylinder block 4 rotates in response to a pushing out force at this point. The first piston 8 and the second piston 9 retract while connected to the low pressure side supply and discharge port 61, and hydraulic fluid is discharged.

[0036] The high pressure hydraulic fluid and the low pressure hydraulic fluid flow in the inner portion of the valve body 60, which is inserted into a center portion of the cylinder block 4, and flows to the volume chambers 10 within the cylinder block 10 via the supply and dis-

charge ports 61 and the cylinder ports 11. The passage configuration is thus simple, and there is little flow resistance for the hydraulic fluid. The supply and discharge efficiency for the hydraulic fluid increases.

[0037] Referring to FIG. 5A, 5B, and 5E, two sets of groove shape ports 66 that open in an axial direction of each of the supply and discharge ports 61 are formed in the outer circumferential surface of one end of the valve body 60. The groove shape ports 66 are disposed sandwiching the supply and discharge ports 61, and extend in a circular arc shape.

[0038] Hydraulic fluid guided to the supply and discharge ports 61 and the groove shape ports 66 forms an oil film in the gap between the valve body 60 and the bushing 70, and the valve body 60 floats and is supported with respect to the cylinder block 4. The valve body 60 thus rotates smoothly relative to the cylinder block 4.

[0039] When regions of the outer circumferential surface of the valve body 60 having the supply and discharge port 61 that is connected to the high pressure side, and the supply and discharge port 61 that is connected to the low pressure side, are divided in two in a circumferential direction, the supply and discharge ports 61 and the annular shape port 66 that open in the identical region are made to communicate with mutually different through holes 64 and 65.

[0040] In other words, when the through hole 64 that supplies high pressure is connected to one of the supply and discharge ports 61, the through hole 65 that guides low pressure is connected to the annular shape port 66 in the same region. When the through hole 65 of the low pressure side is connected to the other supply and discharge port 61, the through hole 64 of the high pressure side is connected to the annular groove port 66 in the same region.

[0041] Forces that push the valve body 60 to the bushing 70 of the inner circumference of the cylinder block 4 due to pressure guided by the annular shape port 66 and the supply and discharge port 61 are thus made substantially equal in each region of the high pressure side and the low pressure side. It thus becomes possible to prevent excess wear that occurs due to a bias in any one of the circumferential directions that pushes on the valve body 60. Smooth relative rotation also becomes possible.

[0042] Referring to FIGs. 3A and 3B, the cylindrical bushing 70 is disposed in the through hole 12 of the cylinder block 4. The bushing 70 is fixed to the cylinder block 4, thus structuring an inner circumferential wall surface that slides in contact with the valve body 60.

[0043] Referring to FIGs. 4A, 4B, and 4C, holes 11a that connect to the cylinder ports 11 are formed in the bushing 70 at an equal spacing in the circumferential direction. Dummy ports 72 are formed opposite to the cylinder ports 11 on both sides of the holes 11a, sandwiching the holes 11a, in a rotation center axis O direction of the cylinder block 4. Each of the dummy ports 72 has a closed end shape, and is open having a fixed spacing in the circumferential direction of the bushing 70. The

number of dummy ports 72 is set to two times the number of cylinder ports 11.

[0044] The holes 11a are formed in positions opposing the supply and discharge ports 61. Further, the dummy ports 72 are formed in positions opposing the annular shape ports 66.

[0045] Forces that are due to pressure guided by the cylinder ports 11 and the dummy ports 72, which push the valve body 60 to the cylinder block 4, can thus be distributed symmetrically, and with more accuracy, in the rotation center axis O direction, as described above.

[0046] A pair of rear surface drive pistons 33 and 34 that push the first swash plate 30 from behind are disposed in the port block 50 in FIG. 1 as driving means that causes the first swash plate 30 to tilt.

[0047] By selectively controlling drive pressure that is guided to the pistons 33 and 34 by using a pressure control valve (not shown), the tilt angle of the first swash plate 30 can be switched between two levels. It should be noted that pressure receiving portions 39a and 39b that receive drive force from the pistons 33 and 34 are provided to the first swash plate 30.

[0048] Further, a pair of rear surface drive pistons 43 and 44 that push the second swash plate 40 from the rear are disposed in the case 25 as driving means that tilts the second swash plate 40. By selectively controlling the drive pressure that is guided to the pistons 43 and 44 by using a pressure control valve (not shown), the tilt angle of the second swash plate 40 can be switched between two levels. Receiving portions 49a and 49b that receive drive force from the rear surface drive pistons 43 and 44 are provided to the second swash plate 40.

[0049] It should be noted that the first swash plate 30 and the second swash plate 40 are provided so that at maximum tilt, the tilt directions thereof are opposite. In other words, in the state of FIG. 1, the second swash plate 40 tilts in the clockwise direction, and the first swash plate 30 tilts in the counter clockwise direction.

[0050] The displacement (effective capacity volume) of the hydraulic motor 1 changes in three stages by switching the drive pressure that is guided by the pistons 33 and 34, and the pistons 43 and 44.

[0051] FIG. 1 shows positions of the first swash plate 30 and the second swash plate 40 where the displacement of the hydraulic motor 1 is in an intermediate value. In these positions high pressure is guided to the pistons 33 and 44, and low pressure is guided to the pistons 34 and 43. The tilt of the first swash plate 30 thus becomes a minimum (intermediate state), and the tilt of the second swash plate 40 becomes a maximum. It should be noted that the receiving portion 39b of the first swash plate 30 contacts a bottom surface 50a of the port block 50, and the receiving portion 49a of the second swash plate 40 contacts a bottom surface 25a of the case 25 in this case.

[0052] In this state the displacement is determined by reciprocal motion of the second piston 9 according to the tilt angle of the second swash plate 40. The displacement of the hydraulic motor 1 in this case becomes one-half

of the maximum capacity volume.

[0053] In contrast, when low pressure is guided to the piston 33 and high pressure is guided to the piston 34 on the first swash plate side from the state of FIG. 1, the first swash plate 30 also tilts. In this case the first piston 8 also moves reciprocally according to the tilt angle of the first swash plate 30. The capacity volume of the volume chamber 10 thus changes according to the total stroke of the first piston 8 and the second piston 9. The displacement of the hydraulic motor 1 in this state becomes the maximum-capacity volume.

[0054] In addition, when high pressure is guided to the piston 43 and low pressure is guided to the piston 44 on the second swash plate side from the state of FIG. 1, the second swash plate 40 stands up perpendicularly with respect to the tilted state shown in the figure, and the tilt angle becomes substantially zero. In this case the stroke of the second piston 9 becomes zero, and the stroke of the first piston 8 is also zero. Accordingly, a capacity volume change in the volume chamber 10 does not occur, and the displacement of the hydraulic motor 1 becomes a minimum.

[0055] When the displacement of the hydraulic motor 1 is the maximum value, the rotational velocity of the hydraulic motor becomes a maximum, while the rotational velocity of the hydraulic motor 1 takes on an intermediate value when the displacement of the hydraulic motor 1 is the intermediate value. The rotational velocity becomes zero in this embodiment when the displacement is the minimum.

[0056] The rotational velocity of the hydraulic motor 1 changes in proportion to the flow rate of the hydraulic fluid that is sent in from a hydraulic pump (not shown). Consequently, the transmission ratio as an HST changes by thus switching the displacement (effective capacity volume) of the hydraulic motor 1.

[0057] The first piston 8 and the second piston 9 are provided to the hydraulic motor 1, and the maximum capacity volume thus becomes larger even when the diameter of the cylinder block 4 remains the same. Accordingly, it becomes possible to make the hydraulic motor 1 smaller and lighter weight even though the effective capacity volume is large.

[0058] This invention is not limited by the embodiments described above, and this invention can also be applied to a swash plate type hydraulic pump.

Claims

1. A swash plate type hydraulic pump or motor comprising:

a cylinder block (4) supported so as to be free to rotate within a pump case (25);
a plurality of cylinder bores (6, 7) formed in the cylinder block (4) from both sides in an axial direction, respectively, the plurality of cylinder

bores (6, 7) communicating with each other;
 a first piston (8) inserted into the cylinder bore (6) of one side of the cylinder block (4);
 a second piston (9) inserted into the cylinder bore (7) of the other side of the cylinder block (4);

a volume chamber (10) formed in inner portion of the cylinder bore (6, 7) and defined by the first piston (8) and the second piston (9);

a first swash plate (30) disposed on one side in an axial direction of the cylinder block (4), with which the first piston (8) is in sliding contact;

a second swash plate (40) disposed on the other side in an axial direction of the cylinder block (4), with which the second piston (9) is in sliding contact;

a rod shape valve body (60) that is inserted into a through hole (12) formed in a shaft center of the cylinder block (4), the rod shape valve body (60) relatively rotating to the cylinder block (4);

a pair of supply and discharge ports (61) that are disposed in an outer circumferential surface of the valve body (60) and that open in symmetrical positions in a circumferential direction;

a pair of passages (64, 65) that extend in an inner portion of the valve body (60) in an axial direction and that are each connected to one of the pair of supply and discharge ports (61), guiding high pressure and low pressure hydraulic fluid; and

cylinder ports (11) formed in the cylinder block (4) and disposed in positions opposing the supply and discharge ports (61), the cylinder ports (11) connecting the volume chamber (10) and the through hole (12) in the shaft center of the cylinder block (4);

wherein each of the cylinder ports (11) communicates in turn with the high pressure side supply and discharge port (61) of the valve body (60) and the low pressure side supply and discharge port (61) of the valve body (60) according to rotation of the cylinder block (4),

characterized in that

the hydraulic pump or motor further comprises a support hole (55) formed in the pump case, into which an end portion of the valve body (60) is inserted; and

a seal ring (56) disposed between the valve body (60) and the support hole (55);

wherein the end portion of the valve body (60) is elastically supported by the support hole (55) through the seal ring (56).

2. The hydraulic pump or motor as defined in claim 1, further comprising a bushing (70) disposed in the through hole (12) of the cylinder block (4), the bushing (70) supporting the other end portion of the valve body (60).

3. The hydraulic pump or motor as defined in claim 1 or 2, further comprising at least one pair of groove shape ports (66) formed in an outer circumferential surface of the valve body (60), aligned in an axial direction with the supply and discharge ports (61), wherein one of the groove shape ports (66) adjacent to the high pressure side supply and discharge port (61) communicates with the low pressure side, and the other groove shape port (66) adjacent to the low pressure side supply and discharge port (61) communicates with the high pressure side.

4. The hydraulic pump or motor as defined in claim 3, further comprising closed end shape dummy ports (72) formed in an inner circumferential surface of the through hole (12) of the cylinder block (4), positioned opposing the groove shape ports (66), wherein the number of the dummy ports (72) formed is equal to the number of the cylinder ports (11).

5. The hydraulic pump or motor as defined in any one of claims 1-4, further comprising drive pistons (33, 34, 43, 44) that push the first swash plate (30) and the second swash plate (40) in order to change a tilt angle of the first swash plate (30) and a tilt angle of the second swash plate (40), respectively.

Patentansprüche

1. Taumelscheiben-Hydraulikpumpe oder -motor, die/der umfasst:

einen Zylinderblock (4), der so gelagert ist, dass er sich in einem Pumpengehäuse (25) frei drehen kann;

eine Vielzahl von Zylinderbohrungen (6, 7), die in dem Zylinderblock (4) jeweils von beiden Seiten her in einer axialen Richtung ausgebildet sind, wobei die Vielzahl von Zylinderbohrungen (6, 7) miteinander in Verbindung stehen;

einen ersten Kolben (8), der in die Zylinderbohrung (6) einer Seite des Zylinderblocks (4) eingeführt ist;

einen zweiten Kolben (9), der in die Zylinderbohrung (7) der anderen Seite des Zylinderblocks (4) eingeführt ist;

eine Volumenkommer (10), die in einem inneren Abschnitt der Zylinderbohrung (6, 7) ausgebildet ist und durch den ersten Kolben (8) sowie den zweiten Kolben (9) begrenzt wird;

eine erste Taumelscheibe (30), die an einer Seite in einer axialen Richtung des Zylinderblocks (4) angeordnet ist und mit der erste Kolben (8) in Gleitkontakt ist;

eine zweite Taumelscheibe (40), die an der anderen Seite in einer axialen Richtung des Zylinderblocks (4) angeordnet ist und mit der

zweite Kolben (9) in Gleitkontakt ist; einen stangenförmigen Ventilkörper (60), der in ein Durchgangsloch (12) eingeführt ist, das in einer Wellenmitte des Zylinderblocks (4) ausgebildet ist, wobei sich der stangenförmige Ventilkörper (60) relativ zu dem Zylinderblock (4) dreht; ein Paar Zuführ- und -Ablass-Kanäle (61), die in einer Außenumfangsfläche des Ventilkörpers (60) angeordnet sind und die sich an symmetrischen Positionen in einer Umfangsrichtung öffnen;

ein Paar Durchlasse (64, 65), die sich in einem Innenabschnitt des Ventilkörpers (60) in einer axialen Richtung erstrecken und die jeweils mit einem des Paares von Zuführ- und -Ablass-Kanälen (61) verbunden sind und Hochdruck- sowie Niederdruck-Hydraulikfluid leiten; und Zylinderkanäle (11), die in dem Zylinderblock (4) ausgebildet und an Positionen angeordnet sind, die den Zuführ- und -Ablass-Kanälen (61) gegenüberliegen, wobei die Zylinderkanäle (11) die Volumenkammer (10) und das Durchgangsloch (12) in der Wellenmitte des Zylinderblocks (4) verbinden;

wobei jeder der Zylinderkanäle (11) seinerseits entsprechend der Drehung des Zylinderblocks (4) mit dem Hochdruckseiten-Zuführ- und -Ablass-Kanal (61) des Ventilkörpers (60) und dem Niederdruckseiten- Zuführ- und - Ablass- Kanal (61) des Ventilkörpers (60) in Verbindung steht, **dadurch gekennzeichnet, dass**

die Hydraulikpumpe bzw. der Hydraulikmotor des Weiteren ein Lagerungsloch (55) umfasst, das in dem Pumpengehäuse ausgebildet ist und in das ein Endabschnitt des Ventilkörpers (60) eingeführt ist; und

ein Dichtungsring (56) zwischen dem Ventilkörper (60) und dem Lagerungsloch (55) angeordnet ist;

wobei der Endabschnitt des Ventilkörpers (60) von dem Lagerungsloch (55) über den Dichtungsring (56) elastisch getragen wird.

2. Hydraulikpumpe oder -motor nach Anspruch 1, die/der des Weiteren eine Buchse (70) umfasst, die in dem Durchgangsloch (12) des Zylinderblocks (4) angeordnet ist, wobei die Buchse (70) den anderen Endabschnitt des Ventilkörpers (60) lagert.

3. Hydraulikpumpe oder -motor nach Anspruch 1 oder 2, die/der des Weiteren wenigstens ein Paar nutenförmiger Kanäle (66) umfasst, die in einer Außenumfangsfläche des Ventilkörpers (60) in einer axialen Richtung auf die Zuführ- und -Ablass-Kanäle (61) ausgerichtet ausgebildet sind, wobei einer der nutenförmigen Kanäle (66), der an den Hochdruckseiten-Zuführ- und -Ablass-Kanal (61) angrenzt, mit der Niederdruckseite in Verbindung steht und der ande-

re nutenförmige Kanal (66), der an den Niederdruckseiten-Zuführ- und -Ablass-Kanal (61) angrenzt, mit der Hochdruckseite in Verbindung steht.

4. Hydraulikpumpe oder -motor nach Anspruch 3, die/der des Weiteren mit geschlossenem Ende geformte Blindkanäle (72) umfasst, die in einer Innenumfangsfläche des Durchgangslochs (12) des Zylinderblocks (4) ausgebildet sind und den nutenförmigen Kanälen (66) gegenüber angeordnet sind, wobei die Anzahl der ausgebildeten Blindkanäle (72) der Anzahl der Zylinderkanäle (11) gleich ist.

5. Hydraulikpumpe oder -motor nach einem der Ansprüche 1-4, die/der des Weiteren Antriebskolben (33, 34, 43, 44) umfasst, die auf die erste Taumelscheibe (30) und die zweite Taumelscheibe (40) drücken, um einen Neigungswinkel der ersten Taumelscheibe (30) bzw. einen Neigungswinkel der zweiten Taumelscheibe (40) zu ändern.

Revendications

1. Pompe ou moteur hydraulique de type à plateau en biais, comprenant :

un bloc cylindres (4) supporté de manière à être libre de tourner à l'intérieur d'un carter de pompe (25) ;

une pluralité d'alésages de cylindre (6, 7) formés dans le bloc cylindres (4) à partir des deux côtés dans une direction axiale, respectivement, la pluralité d'alésages de cylindre (6, 7) communiquant entre eux ;

un premier piston (8) inséré dans l'alésage de cylindre (6) d'un côté du bloc cylindres (4) ;

un second piston (9) inséré dans l'alésage de cylindre (7) de l'autre côté du bloc cylindres (4) ;

une chambre de volume (10) formée dans la partie interne de l'alésage de cylindre (6, 7) et définie par le premier piston (8) et le second piston (9) ;

un premier plateau en biais (30) disposé d'un côté dans une direction axiale du bloc cylindres (4), avec lequel le premier piston (8) est en contact coulissant ;

un second plateau en biais (40) disposé de l'autre côté dans une direction axiale du bloc cylindres (4), avec lequel le second piston (9) est en contact coulissant ;

un corps de soupape (60) en forme de tige qui est inséré dans un trou débouchant (12) formé dans un centre d'arbre du bloc cylindres (4), le corps de soupape (60) en forme de tige tournant de manière relative par rapport au bloc cylindres (4) ;

une paire d'orifices d'alimentation et de déchar-

ge (61) qui sont disposés dans une surface circonférentielle externe du corps de soupape (60) et qui s'ouvrent dans des positions symétriques dans une direction circonférentielle ;

une paire de passages (64, 65) qui s'étendent dans une partie interne du corps de soupape (60) dans une direction axiale et qui sont chacun raccordés à l'un des orifices de la paire d'orifices d'alimentation et de décharge (61), guidant le fluide hydraulique à haute pression et à basse pression ; et

des orifices de cylindre (11) formés dans le bloc cylindres (4) et disposés dans des positions opposées aux orifices d'alimentation et de décharge (61), les orifices de cylindre (11) raccordant la chambre de volume (10) et le trou débouchant (12) dans le centre d'arbre du bloc cylindres (4) ; dans lequel chacun des orifices de cylindre (11) communique à son tour avec l'orifice d'alimentation et de décharge du côté à haute pression (61) du corps de soupape (60) et l'orifice d'alimentation et de décharge du côté à basse pression (61) du corps de soupape (60) selon la rotation du bloc cylindres (4),

caractérisée en ce que :

la pompe ou le moteur hydraulique comprend en outre un trou de support (55) formé dans le carter de pompe, dans lequel une partie d'extrémité du corps de soupape (60) est insérée ; et une bague d'étanchéité (56) est disposée entre le corps de soupape (60) et le trou de support (55) ;

dans lequel la partie d'extrémité du corps de soupape (60) est supportée de manière élastique par le trou de support (55) par l'intermédiaire de la bague d'étanchéité (56).

2. Pompe ou moteur hydraulique selon la revendication 1, comprenant en outre une douille (70) disposée dans le trou débouchant (12) du bloc cylindres (4), la douille (70) supportant l'autre partie d'extrémité du corps de soupape (60).

3. Pompe ou moteur hydraulique selon la revendication 1 ou 2, comprenant en outre au moins une paire d'orifices (66) en forme de rainure formés dans une surface circonférentielle externe du corps de soupape (60), alignés dans une direction axiale avec les orifices d'alimentation et de décharge (61), dans lequel l'un des orifices (66) en forme de rainure adjacent à l'orifice d'alimentation et de décharge du côté à haute pression (61) communique avec le côté à basse pression, et l'autre orifice (66) en forme de rainure adjacent à l'orifice d'alimentation et de décharge du côté à basse pression (61) communique avec le côté à haute pression.

4. Pompe ou moteur hydraulique selon la revendication

3, comprenant en outre de faux orifices (72) en forme d'extrémité fermée formés dans une surface circonférentielle interne du trou débouchant (12) du bloc cylindres (4), positionnés à l'opposé des orifices (66) en forme de rainure, dans lequel le nombre de faux orifices (72) formés est égal au nombre d'orifices de cylindre (11).

5. Pompe ou moteur hydraulique selon l'une quelconque des revendications 1 à 4, comprenant en outre des pistons d'entraînement (33, 34, 43, 44) qui poussent le premier plateau en biais (30) et le second plateau en biais (40) afin de changer un angle d'inclinaison du premier plateau en biais (30) et un angle d'inclinaison du second plateau en biais (40), respectivement.

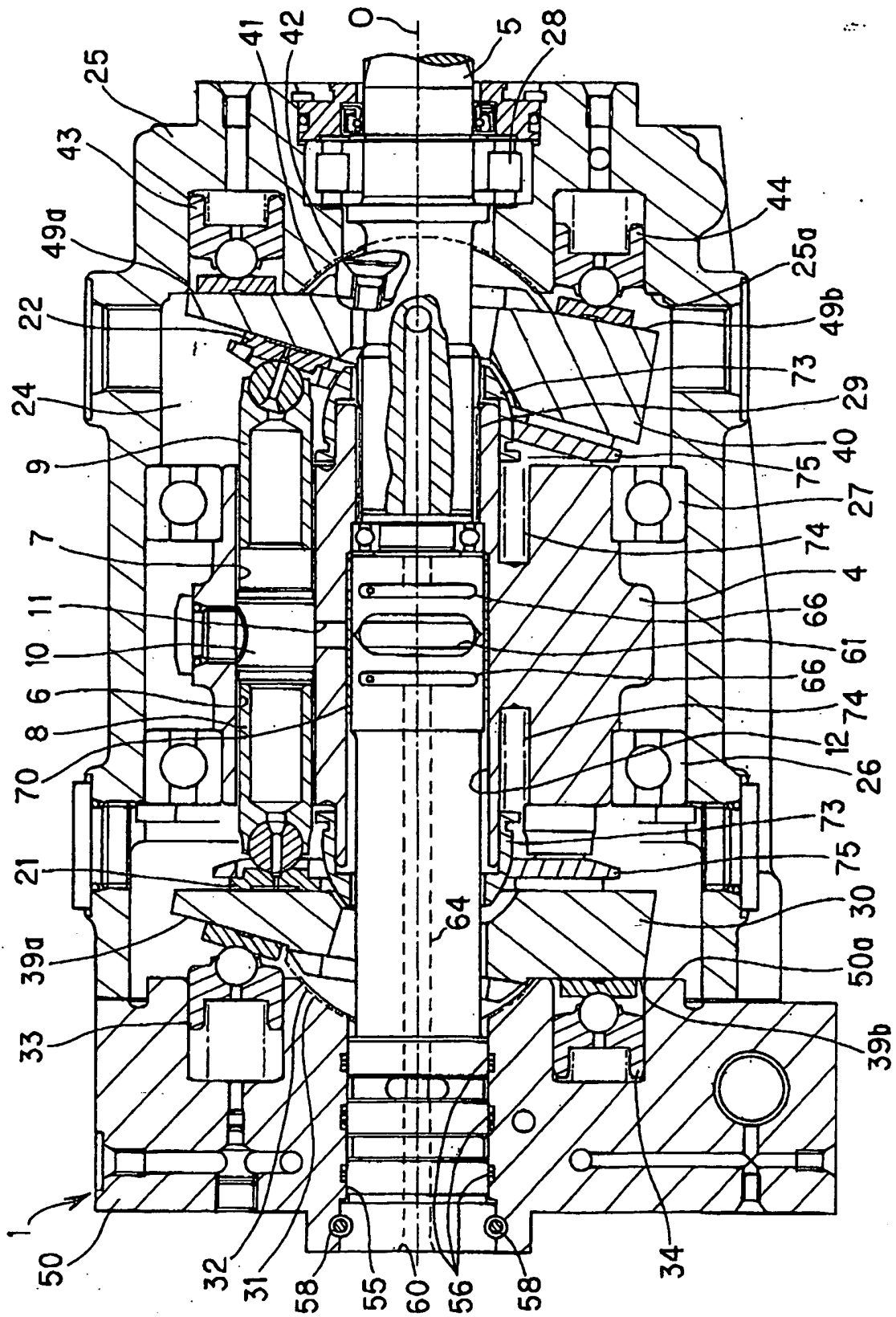

Fig. 1

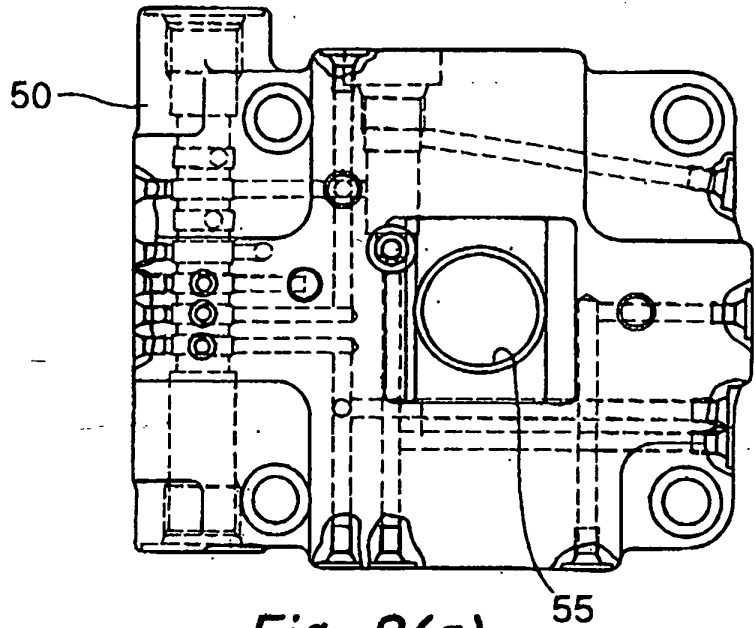

Fig. 2(a)

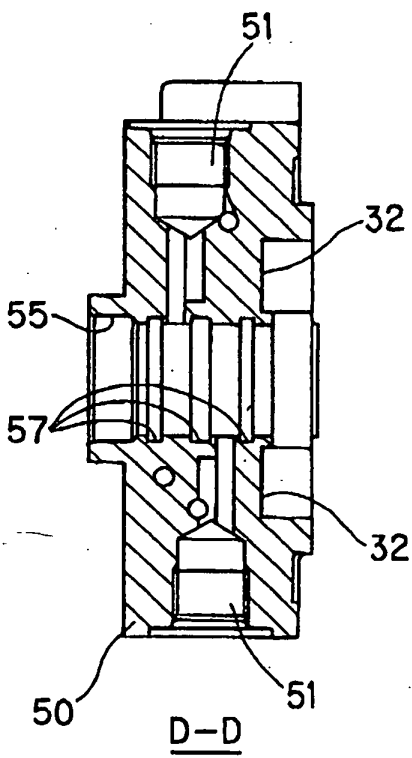

Fig. 2(c)

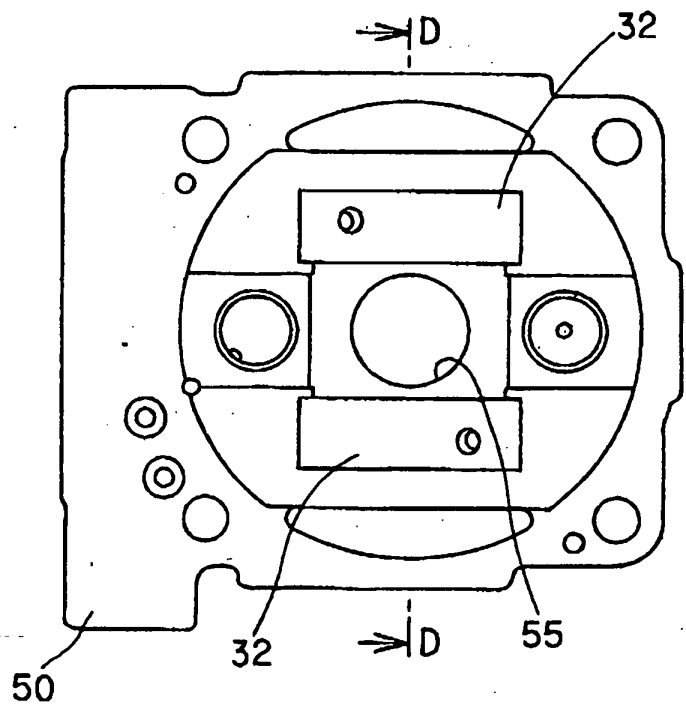

Fig. 2(b)

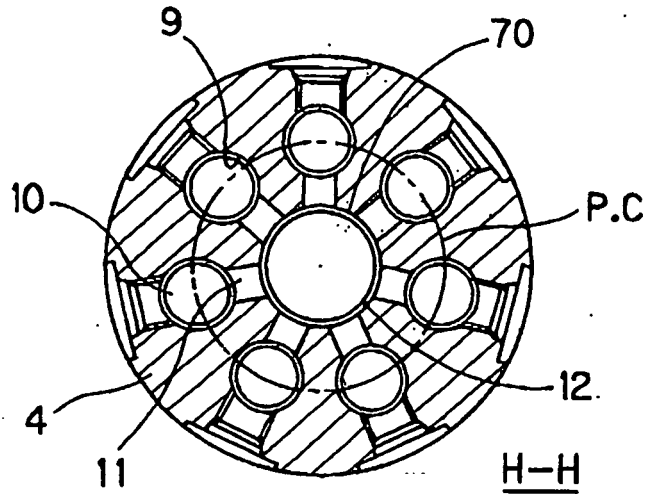

Fig. 3(a)

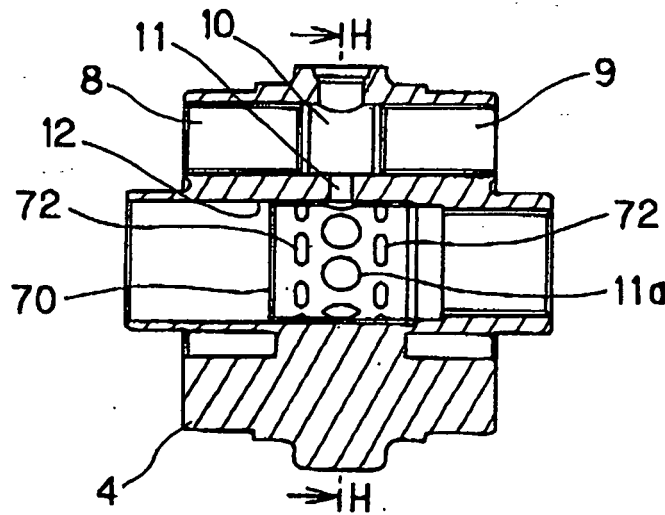

Fig. 3(b)

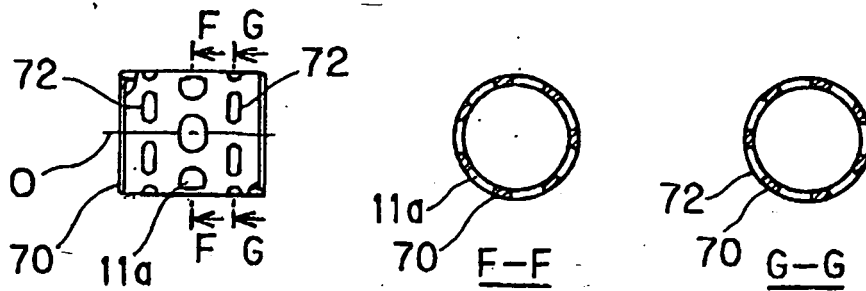

Fig. 4(a) Fig. 4(b) Fig. 4(c)

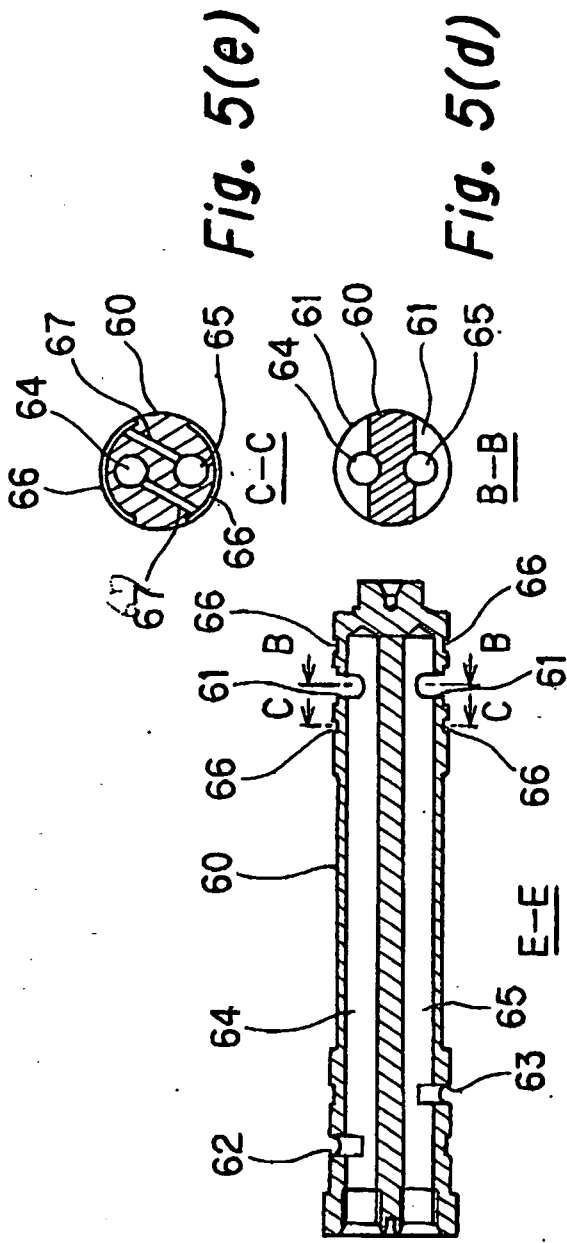

Fig. 5(e)

Fig. 5(d)

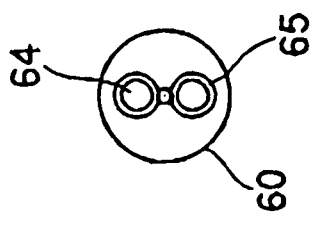

Fig. 5(c)

Fig. 5(b)

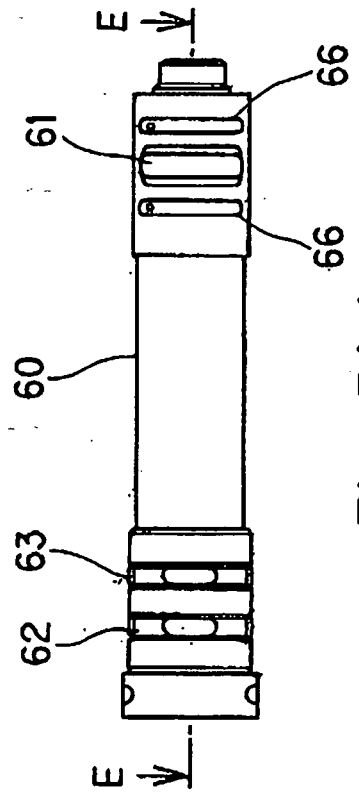

Fig. 5(a)