



(12) **EUROPEAN PATENT APPLICATION**  
published in accordance with Art. 158(3) EPC

- (43) Date of publication: **01.06.2005 Bulletin 2005/22**
- (21) Application number: **03766417.4**
- (22) Date of filing: **22.07.2003**
- (51) Int Cl.7: **B63B 21/04, B63B 21/56**
- (86) International application number: **PCT/ES2003/000377**
- (87) International publication number: **WO 2004/012989 (12.02.2004 Gazette 2004/07)**

(84) Designated Contracting States:  
**AT BE BG CH CY CZ DE DK EE ES FI FR GB GR HU IE IT LI LU MC NL PT RO SE SI SK TR**  
Designated Extension States:  
**AL LT LV MK**

(30) Priority: **26.07.2002 ES 200201765**

(71) Applicants:  
• **Sar Remolcadores, S.L.**  
**08039 Barcelona (ES)**  
• **Encopim, S.L.**  
**08291 Ripollet - Barcelona (ES)**

(72) Inventors:  
• **VILA BOIXADERA, Josep**  
**E-17150 Sant Gregori (Girona) (ES)**  
• **MEDINA VIDAL, Jacinto**  
**E-08030 Barcelona (ES)**  
• **HITOS SANCHEZ, Miguel**  
**C/ Rector Farres I Poch 7-9**  
**E-08820 El de Llobregat (Barcelona) (ES)**

(74) Representative: **Elzaburu, Alberto de**  
**Elzaburu S.A.**  
**Miguel Angel, 21**  
**28010 Madrid (ES)**

(54) **AUTOMATIC SYSTEM FOR TAKING UP AND HANDLING A CONNECTING TOWROPE BETWEEN A TUGBOAT AND A TOWED VESSEL**

(57) The invention relates to an automatic system for taking up and handling a connecting towrope between a tugboat and a towed vessel. The inventive system comprises a fastening carriage which moves on guides around the deck of the tugboat. Once the towrope has been launched from the vessel to be towed, the aforementioned carriage moves along the guide until the built-in sensor detects the presence of the towrope at the upper part of the gunwale. The above-mentioned fastening carriage comprises a clamp and the tow cable

or rope of the tugboat is fixed therein. According to the invention, when the system detects that the towrope has been inserted in the clamp, said clamp is closed and the carriage is released, the tugboat rope remaining connected to the towrope of the vessel. Once the aforementioned operation has been performed, the fastening carriage returns to the rest position thereof. The system operates automatically without the need for any human intervention on the deck of the tugboat and said system is remote controlled from the bridge.

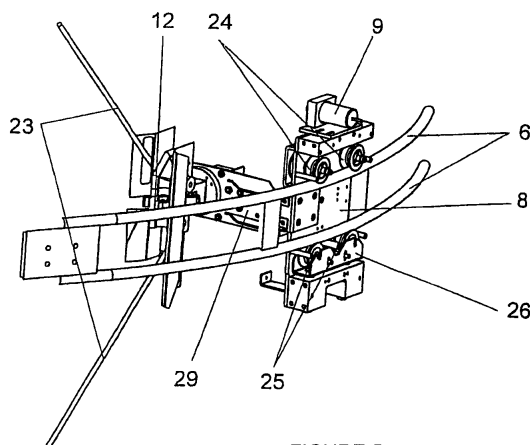

FIGURE 5.

**Description**OBJECT OF THE INVENTION

**[0001]** The present patent of invention application has as an object the registration of an automatic system for taking up and handling a connecting towrope between a tugboat and a towed vessel incorporating notable innovations and advantages compared to the current methods for the same or similar purpose.

**[0002]** More specifically, the new invention comprises an installation for its assembly on the deck of a tugboat, which allows handling the connecting towrope between the tugboat and towed vessel without the necessity of a worker having to be on said deck to perform manual operations. The new invention consists of a fastening carriage which moves on guides around the deck of the tugboat. Once the towrope has been launched from the vessel to be towed, the carriage moves until a built-in sensor detects the presence of the towrope at the level of the gunwale. The fastening carriage fixes the tow cable or rope of the tugboat in the clamp, and once it is detected that the towrope is introduced in the clamp, said clamp is closed and released from the carriage, the cable of the tugboat remaining connected to the towrope of the vessel. Once the operation has been performed, the fastening carriage returns to its rest position.

BACKGROUND OF THE INVENTION

**[0003]** The operation of connecting the tow cable of the port tugboat to the vessel which is ready to enter or exit the port is usually carried out as follows:

- a) The tugboat approaches the vessel from the bow or stern, depending on where the Pilot or Capitan of the vessel which must be connected has instructed.
- b) When the tugboat is close to the vessel, a sailor from the vessel launches a towrope made of braided cable, usually incorporating a ball on the end which is launched so that the weight of the ball drags the thin cable of the towrope, being able to go as far as possible as if a rock had been launched. The ball strikes against the deck of the tugboat, the other end of the towrope remaining on board the vessel, a sailor of which had launched it.
- c) A crew member of the tugboat takes up the towrope which has been launched from the vessel and has landed on the deck. The crew member immediately ties it to the tow cable of the tugboat.
- d1) The vessel begins to take up or heave in the towrope at the same time that, from the tugboat, all the tow cable coiled onto the towing winch is left with slack or loose, or in any case, is let out, actuating its uncoiling from the drum of the towing winch while it is being heaved in from the boat. When the towrope has been taken up from the vessel, tied

thereto is usually a somewhat thicker textile rope which, duly arranged on a capstan or windlass on board, allows taking up the rest of the towline usually formed by a steel cable or by a thick braided textile rope or by a combination of both. When the steel cable forming a loop appears on board the vessel, the loop is rigged on a bitt or haul point, while at the same time from the tugboat the cable is not left loose and the towing winch is stopped, the vessel and tugboat being fixedly connected after this moment. The connecting maneuver has concluded.

d2) The operation described above corresponds to the manner of working in ports in which the tow cable is furnished by the tugboat, the latter being responsible for its storage and good condition. When the tow cable is provided by the boat, the first three operations are the same, and only the last one changes. In this case, it is the sailor of the tugboat who takes up the towrope launched from boat and begins to heave in the tow cable until the loop of the hawser or cable, which is rigged onto the towing hook of the tugboat, reaches him. This way of working is falling into disuse, in detriment of that described above, because the tugboat is responsible for the condition of the cable, and in the case of accidents in vessel maneuvers caused by the breaking of a cable in poor conditions, liability of the tugboat company can be sought.

d) After this moment, the tugboat follows the instructions it receives from the vessel in the sense of hauling in one direction or the other in order to aid the vessel in its port entry or exit maneuver.

**[0004]** Over the years, the way of working has not changed mainly due to the difficulty entailed in the introduction of changes in a way of working that is consolidated over time and in all ports worldwide. The marine elements, bitt, spurling pipe, towrope, capstan, windlass, winch, bollard, loop, cable, etc. are known and used worldwide in all boats and ports of the world. Any change implying the implementation of new devices in vessels and docks will be very difficult to consolidate if it is not imposed worldwide, and only the changes allowing the performance of the same tasks in an easier and simpler manner have possibilities to be successful.

**[0005]** Document publication number 1,023,290 corresponding to a utility model of equipment for vessel rigging and mooring is related to the operation mentioned in d2). However, the applicant has observed that this way of working is falling into disuse. The implementation of the facility disclosed in the publication is unknown by the same, given that of all the tugboats which the inventors have visited, they did not see it implemented.

**[0006]** Document publication number 2,064,206 corresponding to a patent of invention applicable in tugboats is more aimed at the functions of docking and undocking than the operations described above. It partially discloses the application of the invention for a vessel

towing operation in which a telescopic arm performs the connection operation by itself to the towed vessel without needing to perform the previously described operations. The implementation of the invention of this publication is unknown by the inventors and the applicant since its existence has not been verified in any tugboat.

#### DESCRIPTION OF THE INVENTION

**[0007]** The automatic system for taking up and handling a connecting towrope between a tugboat and a towed vessel of the present registration is characterized in that it comprises great advantages without meaning any change whatsoever to the overall connecting process disclosed above corresponding to the current state of the art. The process will continue to be the same and the changes made by the new invention mainly affect the fact that the presence of a crew member on the deck of the tugboat for taking up the towrope and fastening it to the tow cable is not required since this operation is carried out by a fastening carriage.

**[0008]** Said fastening carriage carries out the following operations:

1. Detecting the presence of the towrope at the level of the gunwale where it is supported after having been launched from the vessel to be towed.
2. Fixing the towrope with the clamp.
3. Releasing the clamp from the carriage.
4. Returning to its rest position until a new operation, the start of which must be actuated from the tugboat bridge.

**[0009]** The new invention is made up of a guide rail arranged around the tugboat on which the fastening carriage automatically moves. The fastening carriage has a presence detector which, upon reaching the point where the towrope is located, urges the carriage to stop. A clamp or latch-type gripping system, which carries the tugboat cable secured, grips the towrope, fixes it, and the carriage is released. Once this operation has been performed, the fastening carriage returns to a given position or resting point where it is not in the way. The fastening carriage carries out this process automatically, although the beginning of the process is commanded from the control bridge of the tugboat by pushing the corresponding control on the system control console after the moment in which the ball strikes against the deck and the towrope is supported on the gunwale. System operation can be switched from automatic to manual form also from the control console.

**[0010]** In manual operation, movement the fastening carriage is controlled from the control console. This is because the ball of the towrope can be trapped at some point of the deck, preventing the correct automatic operation of the process. In this manner, should this circumstance occur, the fastening carriage can be commanded from the control bridge of the tugboat to perform

the necessary operations individually so that the ball and the towrope can be released from the obstacles preventing them from automatically operating. Should it be impossible to release the towrope by means of the manual operation on the control console installed in the control bridge, attempting the movements of the fastening carriage individually, the use of a small self-driven vehicle on the deck is further contemplated, with the direction of movement, speed and angle of rotation controlled by radio from the same bridge, as if it were a toy.

**[0011]** The main advantage of the invention with regard to the prior state of the art is that the presence of a crew member on the deck of the tugboat during the connecting operation is not necessary, entailing greater security for the crew. It is necessary to consider that this connecting task is done many times in poor sea and little visibility conditions, with rain, etc., conditions which can cause an accident due to the slipping, tripping or falling of the crew member. The skipper who is in the bridge must pay attention to the vessel to which it is going to connect and at the same time to the crew. With the invention, the skipper must only be concerned with the vessel since there is no crew member on deck. After the moment in which the towrope strikes against the deck, the start button must simply be pushed. The remaining operations are the same as those currently done and are now carried out from the bridge.

**[0012]** To complete the description that will be given below and for the purpose of aiding to better understand its features, a set of illustrative and non-limiting figures are attached to the present specification, in which the most significant details of the invention are represented.

#### BRIEF DESCRIPTION OF THE DRAWINGS

##### **[0013]**

Figure 1 shows a perspective view of a tugboat with the newly invented device.

Figure 2 shows a perspective view of the fastening carriage on the guide rail.

Figure 3 shows a profile view of the carriage on the guide and with the towrope supported on the gunwale.

Figure 4 shows a front perspective view of the inside of the fastening carriage on the guide rail.

Figure 5 shows a rear perspective view of the inside of the fastening carriage on the guide rail.

Figure 6 shows a block diagram of the electronic configuration of the invention.

#### DESCRIPTION OF A PREFERRED EMBODIMENT

**[0014]** In view of the discussed figures and according to the numbering adopted, observed therein is a preferred although non-limiting embodiment of the invention which consists of a guide rail (6) made up of two cylindrical calibrated rails preferably of polished and

tempered stainless steel, which go around all or part of the tugboat (1). These rails (6) are joined by means of screws, welds or the like to the supports (5), which are assembled on the deck (2) of the boat. There is a longitudinally movable fastening carriage (3) on this guide (6).

**[0015]** The fastening carriage (7) comprises a structure or frame (8) incorporating a duly protected electric motor (9) which, by means of rotation reduction pulleys (27) and the corresponding belts (28), is connected to two drive wheels (24) of grooved profile, supported on one of the rails (6) of the guide. In a position opposite to the two drive wheels (24), the frame (8) has two other idle wheels (25) on a support (26) which presses them against the other rail (6) of the guide. In turn, the frame (8) has supports (10) of a rechargeable battery (18) for supplying electrical power to the motor (9) and to control the circuitry (19 and 22). The frame (8) has a projecting arm (29) opposite to the guide (6) with an adjustable mechanism (11) incorporating a clamp mechanism (12) with a sensor (21) for detecting the presence of the towrope (4) and two V-shaped open guiding rods (23) of said towrope (4) supported on the gunwale (3) towards the clamp (12). The rod-clamp (12 and 23) assembly mechanism is arranged at the level of the gunwale (3). The clamp (12) is joined with the cable line (not represented) and is releasable when a lock solenoid (20) thereof joining said cable with the towrope (4) of the towed vessel is actuated.

**[0016]** The control circuitry (19) of the carriage (7) is made up of a radio transmitter equipment, a speed and motor running/stop control, a controller of the sensor (21) of the clamp (12), and an actuator of the lock solenoid (20) of the clamp. The radio transmitter equipment (22) of the carriage (7) is connected to an equivalent radio transmitter equipment (15) in the control console (13) of the bridge for the automatic or manual handling of said carriage (7) with the corresponding controls (14) of speed adjustment, start/stop, movement direction of the carriage (7) and locking of the solenoid (20) of the clamp (12).

**[0017]** The fastening carriage (7) incorporates a recharging mechanism (17) of the battery (18) made up by means of sockets that can be coupled to a base (16) existing at a point that is away from the path of the guide rail (6), or alternatively by means of a non-contact induction charging system. The base (16) of the recharging system can be in its rest position, arranged on the bow or in the area where it is less bothersome. Said recharging system (16) can be secured by means of a latch or catch system which is released in the moment of starting its running from the control console (13).

## Claims

1. An automatic system for taking up and handling a connecting towrope between a tugboat and a towed

vessel, suitable for the joining of the cable line of the tugboat with the connecting towrope of the towed vessel automatically and without the aid of any crew member on deck, **characterized in that** it comprises a fastening carriage (7) that can move on a guide rail (6) existing on the entire or part of the surrounding contour of the deck (2) of the tugboat (1) and at height approaching the gunwale (3); and **in that** the fastening carriage (7) comprises drive means on the guide rail (6) autonomously; and **in that** the fastening carriage (7) comprises a clamp (12) joined with the cable line (not represented) for the joining of said cable with the towrope (4) launched from the towed vessel; and **in that** the fastening carriage (7) is connected by means of a control circuit (19) with a remote control console (13) for its automatic or manual operation.

2. An automatic system for taking up and handling a connecting towrope between a tugboat and a towed vessel according to claim 1, **characterized in that** the carriage (7) is made up of a frame (8) having a set of drive wheels (24) connected to a motor (9) and applied on the guide rail (6); and **in that** existing between the motor (9) and the drive wheels (24) is a set of transmission and reduction pulleys (27) and belts (28) or the like.

3. An automatic system for taking up and handling a connecting towrope between a tugboat and a towed vessel according to claims 1 and 2, **characterized in that** the frame (8) comprises a set of idle wheels (25) applied on the guide rail (6); and **in that** said set of idle wheels (25) is arranged opposite to the set of drive wheels (24); and **in that** said set of idle wheels (25) is arranged within a compressing footing or support (26) or the like.

4. An automatic system for taking up and handling a connecting towrope between a tugboat and a towed vessel according to claims 1, 2 and 3, **characterized in that** the guide rail (6) is made up of a pair of preferably cylindrical rails arranged parallel and aligned notably vertical or inclined; and **in that** the guide rail (6) is held by a series of supports (5) on the deck (2) of the tugboat (1); and **in that** the set of drive wheels (24) has a grooved contour in correspondence with the rail of the guide rail (6) on which it is applied; and **in that** the set of idle wheels (25) has a grooved contour in correspondence with the rail of the guide rail (6) on which it is applied.

5. An automatic system for taking up and handling a connecting towrope between a tugboat and a towed vessel according to claims 1 and 2, **characterized in that** it comprises a battery (18) supplying power in the carriage (7); and **in that** the frame (8) comprises supports (10) of said battery (18).

6. An automatic system for taking up and handling a connecting towrope between a tugboat and a towed vessel according to claims 1, 2 and 3, **characterized in that** it comprises a battery (18) charger (16) installed in the suitable area of the guide rail (6) not coinciding with the conventional working area; and **in that** the carriage (7) comprises a recharging mechanism (17) for the battery (18) that can be coupled with the charger (16) with or without contact. 5  
10
7. An automatic system for taking up and handling a connecting towrope between a tugboat and a towed vessel according to claim 1, **characterized in that** the control circuit (19) existing in the carriage (7) has communication with the control console (13) by means of radio transmission wireless communication (15 and 22) or the like. 15
8. An automatic system for taking up and handling a connecting towrope between a tugboat and a towed vessel according to claim 1, **characterized in that** the carriage (7) comprises an arm (29) projecting from the frame (8) incorporating a clamp mechanism (12) with a sensor (21) detecting the presence of the towrope (4); and **in that** the mechanism of the clamp (12) comprises two open V-shaped guide rods (23) of the towrope (4) supported on the gunwale (3) towards the clamp (12). 20  
25
9. An automatic system for taking up and handling a connecting towrope between a tugboat and a towed vessel according to claims 1 and 8, **characterized in that** the projecting arm (29) has an adjustable mechanism (11) of the clamp mechanism (12). 30  
35
10. An automatic system for taking up and handling a connecting towrope between a tugboat and a towed vessel according to claims 1 and 8, **characterized in that** the clamp (12) comprises a lock solenoid (20) on the towrope (4) for their connection and the release of said clamp (12). 40
11. An automatic system for taking up and handling a connecting towrope between a tugboat and a towed vessel according to claims 1 and 7, **characterized in that** the control console (13) comprises controls (14) and automatic or manual actuation means of the fastening carriage (7); and **in that** the control circuit (19) comprises a speed and motor running/stop control, a controller of the sensor (21) of the clamp (12), an actuator of the lock solenoid (20) of the clamp (12). 45  
50  
55

FIGURE 1.

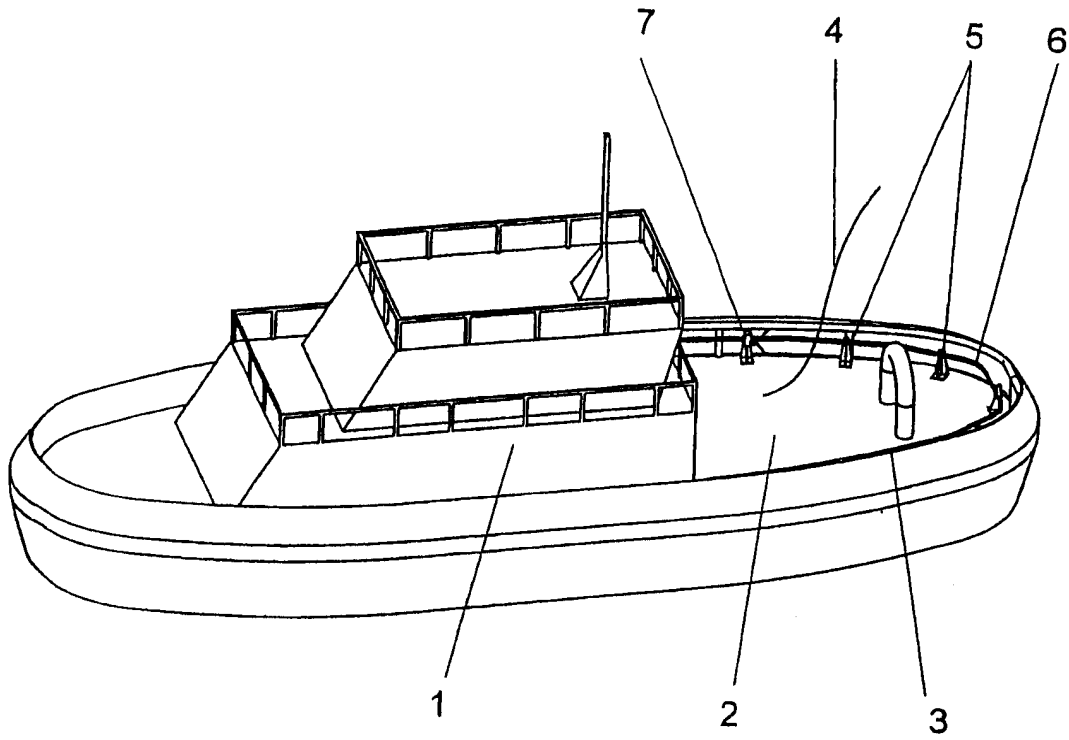

FIGURE 2.

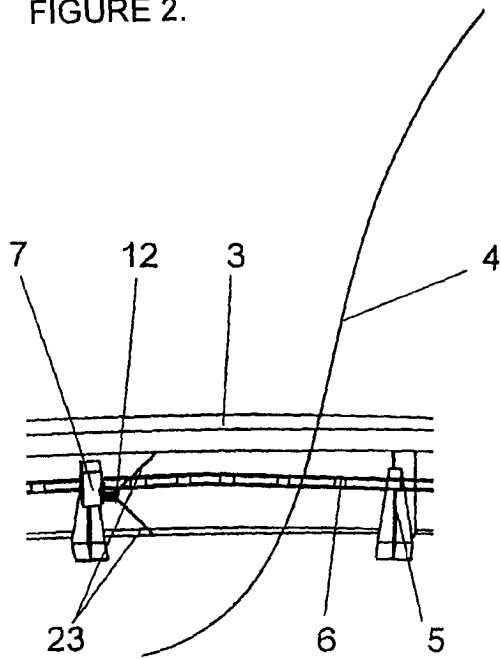

FIGURE 3.

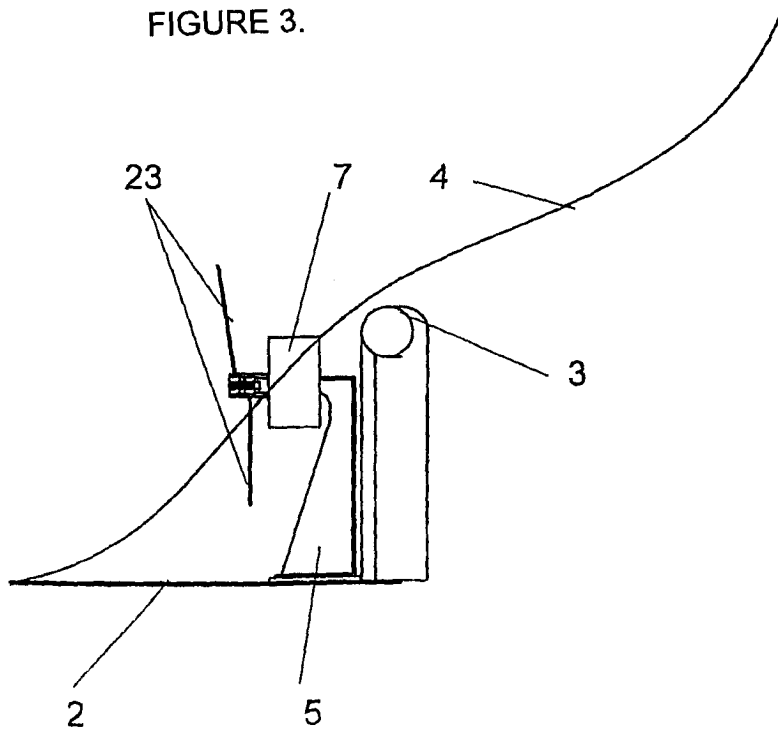

FIGURE 4.

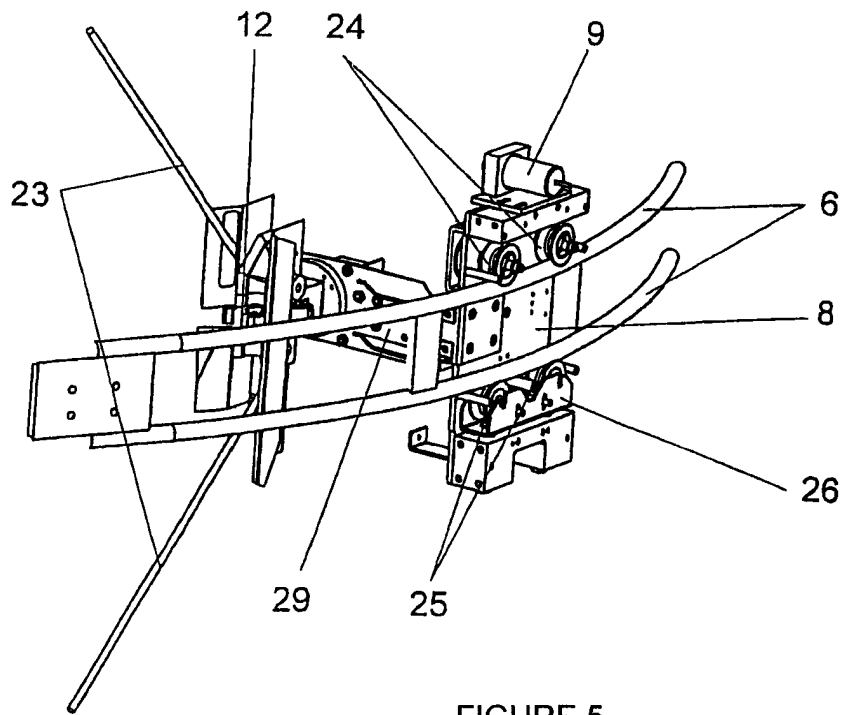
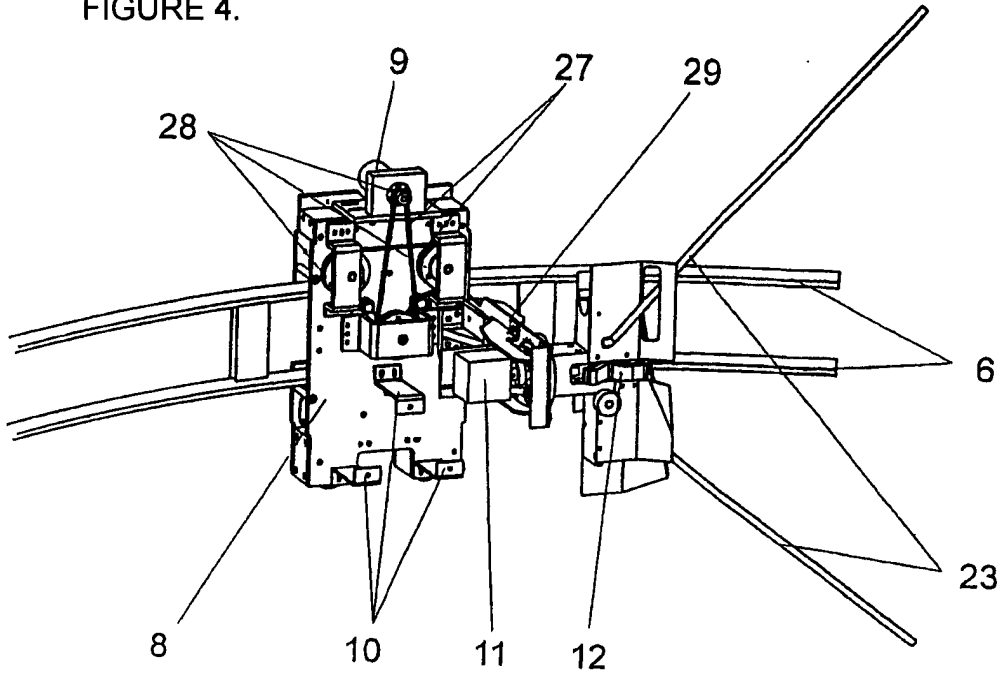
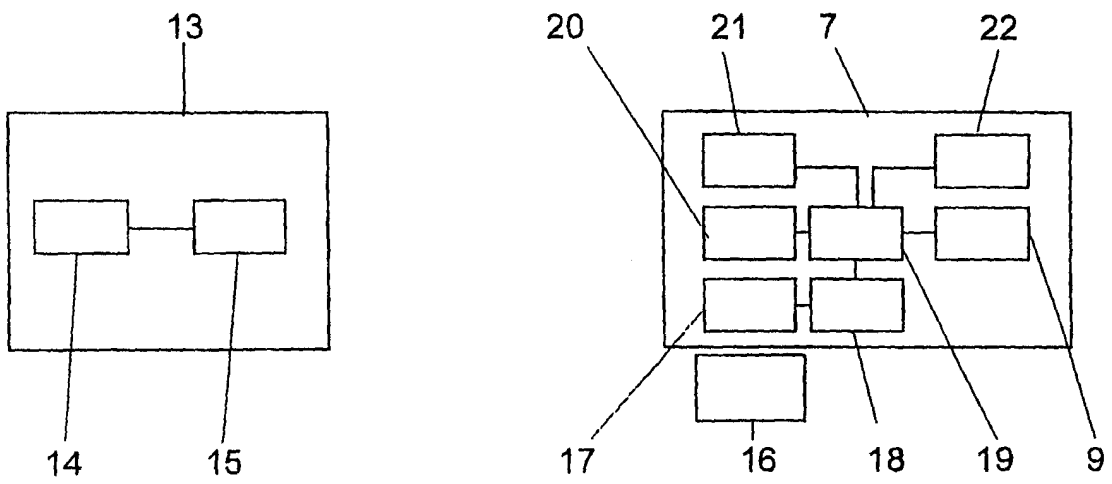

FIGURE 5.



FIGURE 6.



## INTERNATIONAL SEARCH REPORT

International application No.

PCT/ ES 03/ 00377

A. CLASSIFICATION OF SUBJECT MATTER <b>IPC 7 B63B 21/04, B63B 21/56</b> According to International Patent Classification (IPC) or to both national classification and IPC		
B. FIELDS SEARCHED Minimum documentation searched (classification system followed by classification symbols) <b>IPC 7 B63B</b> Documentation searched other than minimum documentation to the extent that such documents are included in the fields searched		
Electronic data base consulted during the international search (name of data base and, where practicable, search terms used) <b>EPODOC, OEPMPAT, PAJ, WPI.</b>		
C. DOCUMENTS CONSIDERED TO BE RELEVANT		
Category*	Citation of document, with indication, where appropriate, of the relevant passages	Relevant to claim No.
X A	ES 1 023 207 U (GARCÍA PARGA) <b>16 June 1993</b> (16.06.93), <b>The whole document 13</b>	1-8 9-11
A	WO 97 11876 A1 (WILLEM POT B.V.) <b>3 April 1997</b> (03.04.97), <b>page 4, line 29 - page 5, line 13, figures 1, 2.</b>	1
A	WO 00 35745 A1 (HELGESEN) <b>22 June 2000</b> (22.06.00), <b>The whole document</b>	1
<input type="checkbox"/> Further documents are listed in the continuation of Box C. <input checked="" type="checkbox"/> See patent family annex.		
* Special categories of cited documents: "A" document defining the general state of the art which is not considered to be of particular relevance "E" earlier document but published on or after the international filing date "L" document which may throw doubts on priority claim(s) or which is cited to establish the publication date of another citation or other special reason (as specified) "O" document referring to an oral disclosure, use, exhibition or other means "P" document published prior to the international filing date but later than the priority date claimed "T" later document published after the international filing date or priority date and not in conflict with the application but cited to understand the principle or theory underlying the invention "X" document of particular relevance; the claimed invention cannot be considered novel or cannot be considered to involve an inventive step when the document is taken alone "Y" document of particular relevance; the claimed invention cannot be considered to involve an inventive step when the document is combined with one or more other such documents, such combination being obvious to a person skilled in the art "&" document member of the same patent family		
Date of the actual completion of the international search <b>31 OCT 2003 (31.10.03)</b>	Date of mailing of the international search report <b>12 NOV 2003 (12.11.03)</b>	
Name and mailing address of the ISA/ <b>S.P.T.O.</b>	Authorized officer	
Facsimile No.	Telephone No.	

Form PCT/ISA/210 (second sheet) (July 1992)

**INTERNATIONAL SEARCH REPORT**  
Information on patent family members

International Application No  
PCT/ ES 03/ 00377

Patent document cited in search report	Publication date	Patent family member(s)	Publication date
ES 1023207 U	16-06-1993	ES 1023207 Y	01-01-1994
WO 9711876 A	03-04-1997	NL 1001302 C AU 7147196 A	28-03-1997 17-04-1997
WO 0035745 A	22-06-2000	NO 985595 A AU 1587000 A	31-05-2000 03-07-2000