



(12) **EUROPEAN PATENT APPLICATION**

(43) Date of publication:
08.06.2005 Bulletin 2005/23

(51) Int Cl.7: **A63H 33/30**

(21) Application number: **04380240.4**

(22) Date of filing: **26.11.2004**

(84) Designated Contracting States:
**AT BE BG CH CY CZ DE DK EE ES FI FR GB GR
HU IE IS IT LI LU MC NL PL PT RO SE SI SK TR**
Designated Extension States:
AL HR LT LV MK YU

(72) Inventor: **Ferri Llorens, Jaime**
03430 Onil Alicante (ES)

(74) Representative:
Garcia-Cabrerizo y del Santo, Pedro Maria
Oficina Garcia Cabrerizo, S.L.,
Vitruvio, 23
28006 Madrid (ES)

(30) Priority: **02.12.2003 ES 200302836**

(71) Applicant: **FABRICAS AGRUPADAS DE
MUNECAS DE ONIL, S.A.**
03430 Onil (Alicante) (ES)

(54) **Toy pacifier**

(57) The toy pacifier comprises a teat (1) incorporating an electrical contact (29) actuated by a push button (2) activating an oscillating mechanism (3) integral to the teat (1), and the actuator (4) of which transmits the movement to a pusher (5) joined to a casing (6) forming part of the outer envelopment (7) of the pacifier, which is articulated on housings (8) which the oscillating mechanism (3) has. The outer envelopment (7) thus oscillates when the teat (1) is introduced and trapped in

the mouth (30) of a passive doll.

In a preferred embodiment, the oscillating mechanism (3) is constituted of an electric motor (20) which, powered by a battery (19) and through a pinion gear (21), drives an idler wheel (22) integral to a worm gear (23). The corresponding crown gear (24) is joined to a cam (25) functioning in a receiver port (27) of the actuator (4) which, as a result, oscillates with regard to a fixed shaft (26) in a half-box (17) of the oscillating mechanism (3).

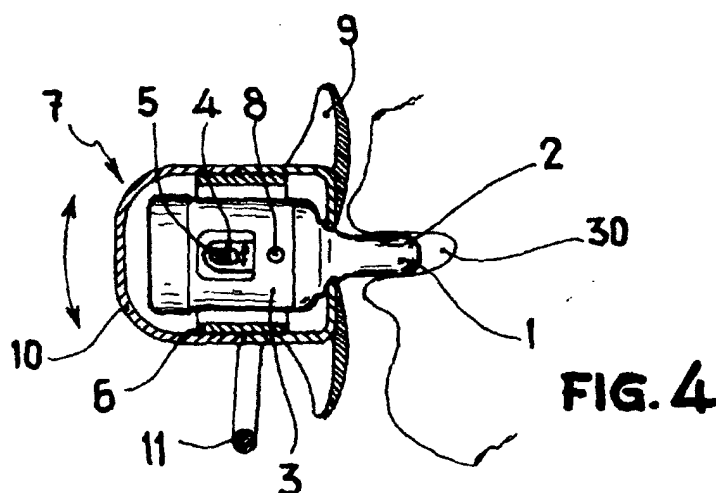

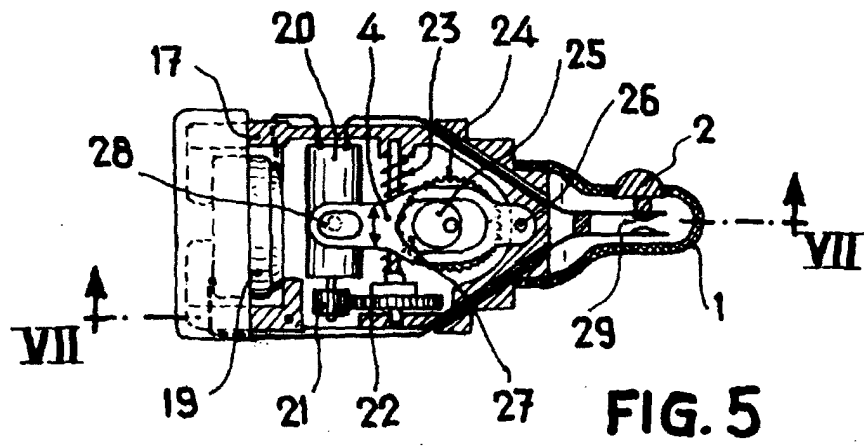

Description

[0001] The present invention refers to a functional toy pacifier, able to interact with a passive doll.

[0002] Dolls which, by means of the mobilization of an internal mechanism, simulate the movements of the mouth which a baby carries out when sucking on a pacifier are known. The simulation of the movement itself has no major difficulties, given its simplicity, the different implementations being distinguished according to the mechanism chosen to carry them out. The realistic quality of these dolls is very satisfactory, but it has been found that their duration is short due to the complexity of the mechanism, which must furthermore be located inside the head of the doll, which offers difficulties for a good securing. Added to this is the necessity to provide for means of transmitting the movement generated by the mechanism to the flexible lips of the doll. As a result, it is very frequent that with the blows and shaking that dolls are subjected to due to the action of their users, either the mobilization mechanism or the means of transmitting the movement will undergo misadjustments and displacements which end up causing the end of their useful life.

[0003] Evidently, the degree of reliability of any mechanism can be improved by paying the necessary attention to the design, manufacture, and assembly of its components, but this necessarily leads to raising the costs of the product.

[0004] It can therefore be asserted that the mechanisms known for a doll to simulate the action of sucking are fragile and of short duration, or they have a high cost. Furthermore, they force providing for a housing, usually in the back of the doll, for the batteries supplying power to the mechanism, making it impossible to carry out certain operations with it, such as bathing it for example.

[0005] It is an object of the invention to achieve that a doll appears to be sucking a pacifier, and the mechanism of which is highly reliable.

[0006] It is another object of the invention to achieve that once the pacifier is removed from the mouth of the doll, the latter can be treated without excessive considerations, subjecting it to certain operations, for example bathing it, which would lead to the destruction of the dolls representative of the prior art.

[0007] The proposed objective is achieved by simply eliminating any mechanism from inside the doll, transferring it to the pacifier. The proposed solution is based on the fact that the movement of the mouth transmits an oscillation to the pacifier, and the latter is what the observer basically perceives.

[0008] The pacifier of the invention comprises an oscillating mechanism joined to the teat, which incorporates a push button for detecting that the pacifier has been introduced in the mouth of the doll. A pacifier-shaped outer envelopment is arranged on the teat-oscillating mechanism assembly in an articulated manner, comprising a casing provided with a pusher collaborat-

ing with an actuator constituting the movable outlet of the oscillating mechanism. In this manner, when the teat is introduced in the mouth of the doll, the former is tightly held and, accordingly, so is the oscillating mechanism.

5 Actuation of the latter due to the pressure of the lips of the doll on the push button causes an oscillating movement of the actuator, which is transmitted to the casing pusher and, as a result, to the entire outer envelopment of the pacifier. In the context of this document, it will be understood that an oscillating mechanism necessarily comprises a power source, an electric motor, and a speed reducer ending in the aforementioned actuator.

10 **[0009]** If a shield is provided for on the front of the outer envelopment of the pacifier that is large enough to hide the lips of the doll, the observer will think that the pacifier oscillates as a result of the movement of the mouth of the doll, when in reality the teat and the oscillating mechanism remain immobile. In short, a relative movement has been introduced between the teat and the rest of the pacifier, and given that the teat is fixed, the rest of the pacifier will oscillate.

15 **[0010]** The underlying novel concept in the present invention implies surprising effects leading to considerable advantages, such as:

- 25 - The apparent sucking action can be incorporated in any preexisting passive doll simply with the hole of its mouth being compatible with the teat of the pacifier of the invention, which on the other hand does not require excessively complex operating conditions.
- 30 - Once the new pacifier is removed from the mouth of the doll, the latter does not contain any electro-mechanical mechanism whatsoever, whereby it is not necessary to take special care in the handling thereof.
- 35 - The necessarily miniaturized oscillating mechanism can be designed in an extraordinarily compact manner, it is not fixed to the doll, and is protected from blows due to the outer envelopment itself of the pacifier with regard to which, being articulated, has an allowance which, to an extent, makes it independent.

40 **[0011]** To complement the foregoing description and for the purpose of aiding to better understand the features of the invention, a detailed description of a preferred embodiment will be given on the basis of a set of drawings attached to this specification and in which the following has been shown with a merely orientative and non-limiting character:

45 Figure 1 shows an elevational view of the pacifier of the invention.

50 Figure 2 shows a rear view of the pacifier of the invention.

Figure 3 shows an elevational view of the pacifier of the invention, partially disassembled.

Figure 4 shows a schematic sectional view of the pacifier of the invention.

Figure 5 shows an internal elevational view of the oscillating mechanism of the pacifier of the invention.

Figure 6 shows an internal view, similar to that of Figure 5, in which the actuator has been removed and the teat has been represented in exploded view.

Figure 7 shows a schematic sectional plan view of the inside of the pacifier of the invention.

Figure 8 shows a plan view of the casing of the outer envelopment with its pusher.

Figure 9 shows a front view of the casing represented in Figure 8.

Figure 10 shows an elevational view of the casing represented in Figure 8.

Figure 11 shows the electrical diagram of the pacifier of the invention.

[0012] The reference numbers in the foregoing figures correspond to the following parts and elements:

- 1.- Teat
- 2.- Push button
- 3.- Oscillating mechanism
- 4.- Actuator
- 5.- Pusher
- 6.- Casing
- 7.- Outer envelopment
- 8.- Housing
- 9.- Front shield
- 10.- Rear shield
- 11.- Securing ring
- 12.- Right half-casing
- 13.- Left half-casing
- 14.- Pins
- 15.- Articulation lugs
- 16.- Holes
- 17.- Lower half-box
- 18.- Upper half-box
- 19.- Battery
- 20.- Electric motor
- 21.- Pinion gear
- 22.- Idler wheel
- 23.- Worm gear
- 24.- Crown gear
- 25.- Cam
- 26.- Shaft
- 27.- Receiver port
- 28.- Drive port
- 29.- Electrical contact
- 30.- Mouth of a doll

[0013] As can be seen in Figures 1 to 4, in a preferred embodiment, the pacifier the invention consists of a teat (1) incorporating a push button (2), integrally joined to an oscillating mechanism (3) having an actuator (4) col-

laborating with a pusher (5) integral to a casing (6) forming part of an outer envelopment (7); the casing (6) being articulated on two housings (8) of the oscillating mechanism (3).

[0014] The outer envelopment (7) is basically constituted of the casing (6), on which a front shield (9) and a rear shield (10) are assembled by means of pressure fit. A securing ring (11) articulated on the casing (6) allows hanging the pacifier from the neck of the doll. See Figure 3.

[0015] The casing (6) itself is formed by a right half-casing (12) and a left half-casing (13) joined by means of pins (14). Both half-casings have articulation lugs (15) intended for being introduced in the corresponding housings (8) of the oscillating mechanism (3), as well as respective holes (16) intended for receiving the securing ring (11). The right half-casing (12) furthermore incorporates the pusher (5) which collaborates with the actuator (4) of the oscillating mechanism (3). See Figures 8 to 10.

[0016] As can be seen in Figures 5 to 8, the oscillating mechanism (3) comprises a lower half-box (17) and an upper half-box (18) between which a battery (19) and an electric motor (20) are arranged. The output pinion gear (21) of the electric motor (20) meshes with an idler wheel (22) integral to a worm gear (23), the corresponding crown gear (24) of which is integral to a cam (25). The actuator (4), articulated on a fixed shaft (26) in the half-boxes (17), (18), has a receiver port (27) in which the cam (25) functions, and a drive port (28) in which the pusher (5) of the casing (6) is introduced.

[0017] The teat (1) pressure-mounted on the front area of the half-boxes (17), (18) of the oscillating mechanism (3), and has in its upper portion a push button (2) acting on an electrical contact (29). The circuit diagram can be seen in Figure 11.

[0018] The operation of the pacifier object of the invention is as follows. When the teat (1) is introduced in the mouth (30) of a doll, the oscillating mechanism (3) will be firmly held. Given that the push button (2) will remain pressed, the electrical contact (29) will close and as a result, the electric motor (20) will be powered by the battery (19). The output pinion gear (21) of the motor will move the idler wheel (22) and the latter will move the worm gear (23), which will cause the rotation of the crown gear (24) and the cam (26). The rotation of the latter will cause the oscillation of the actuator (4) with regard to the shaft (26), dragging the outer envelopment (7) by means of the pusher (5) of the casing (6) and transmitting an oscillating movement to it with regard to the articulation lugs (15) retained in the housings (8) of the oscillating mechanism (3).

[0019] A series of variants and alternatives which allow adapting the end product to different commercial, production, or economic considerations will be evident for a person skilled in the art. In that sense, the worm gear (23) and crown gear (24) assembly could be replaced by several gear wheels or by any equivalent reducer mechanism, and the push button (2) could be in-

side the teat (1), or even not exist at all, if the latter is flexible enough so as to be able to act through itself on the electrical contact (29). Finally, it must be pointed out that while Figures 1 to 4 are drawn in an approximate actual size, Figures 5 to 10 are considerably enlarged in order to suitably be able to see the shape and arrangement of the different internal elements.

Claims

1. A toy pacifier **characterized by** comprising:

a teat (1) incorporating an electrical contact (29),
 an oscillating mechanism (3), integral to the teat (1), incorporating an actuator (4) of oscillating movement when the electrical contact (29) is closed,
 and an outer envelopment (7), mounted by articulation on the oscillating mechanism (3), which incorporates a casing (6) provided with a pusher (5) collaborating with the actuator (4).

2. A toy pacifier according to claim 1, **characterized in that** the outer envelopment (7) comprises a front shield (9) and a rear shield (10) tightly mounted on the casing (6).

3. A toy pacifier according to claim 2, **characterized in that** the casing (6) is constituted of a right half-casing (12) and a left half-casing (13) having respective articulation lugs (15) intended for being introduced in corresponding housings (8) of the oscillating mechanism (3).

4. A toy pacifier according to claim 3, **characterized in that** the pusher (5) is incorporated to one of the two half-casings (12), (13).

5. A toy pacifier according to claim 1, **characterized in that** the teat incorporates a push button (2) acting on the electrical contact (29).

6. A toy pacifier according to claim 1, **characterized in that** the oscillating mechanism (3) comprises a lower half-box (17) and an upper half-box (18) between which a battery (19) and an electric motor (20) are arranged, an output pinion gear (21) of the electric motor (20) meshing with an idler wheel (22) integral to a worm gear (23), the corresponding crown gear (24) of which is integral to a cam (25) functioning in a receptor port (27) of an actuator (4) articulated on a fixed shaft (26) in the half-boxes (17), (18), the actuator (4) having a drive port (28) where the pusher (5) of the casing (6) is introduced.

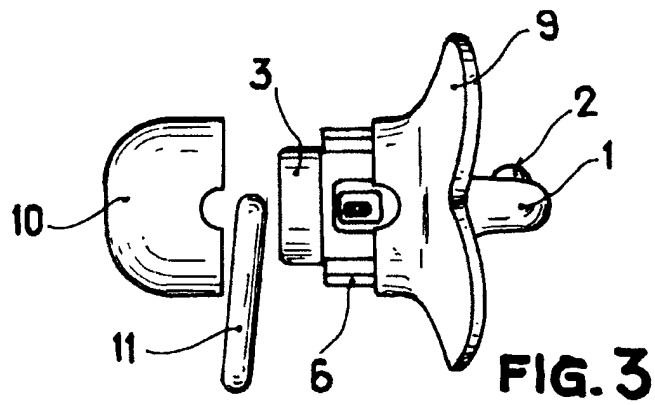
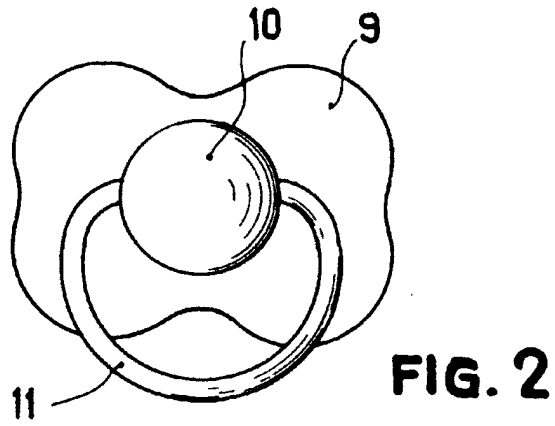
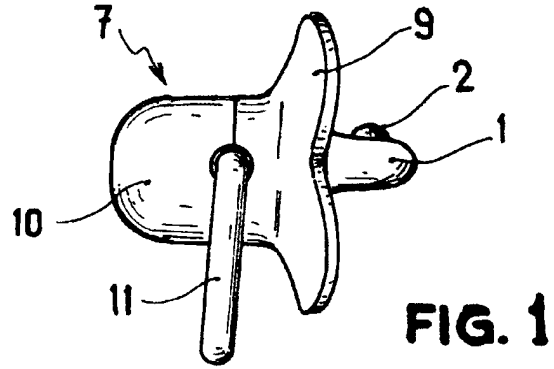

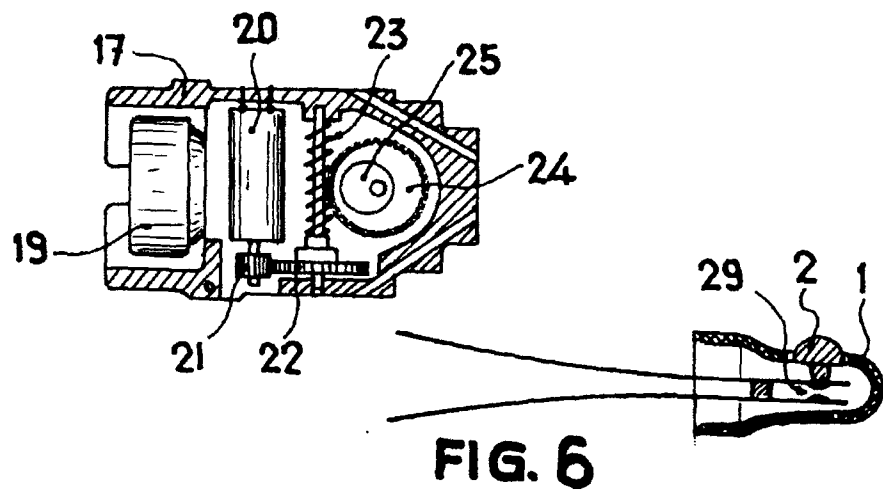
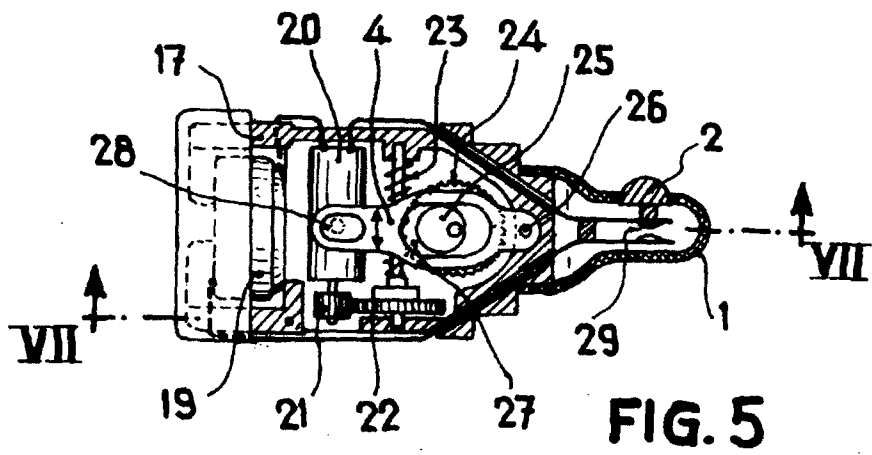
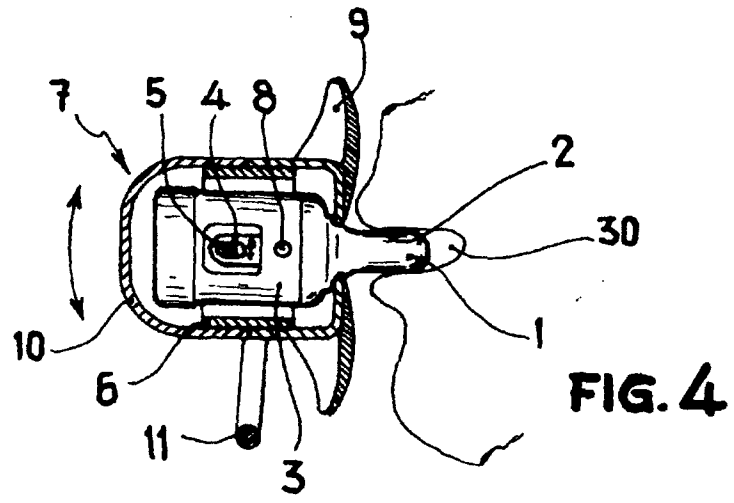

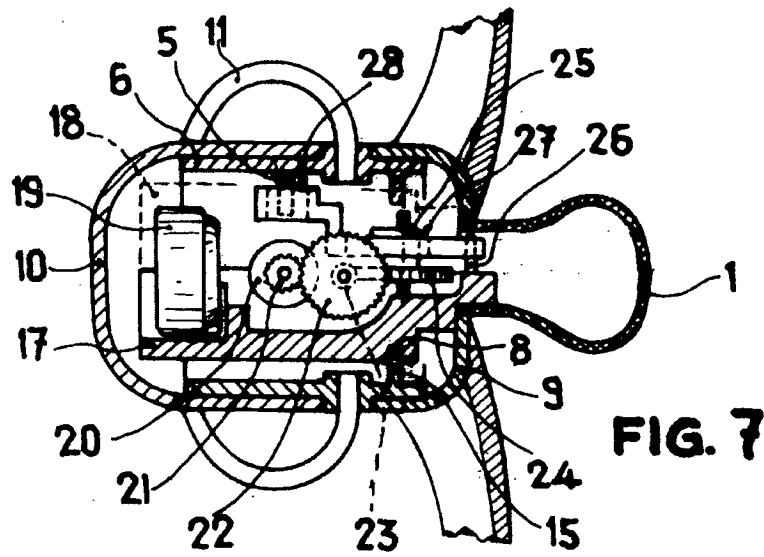

FIG. 7

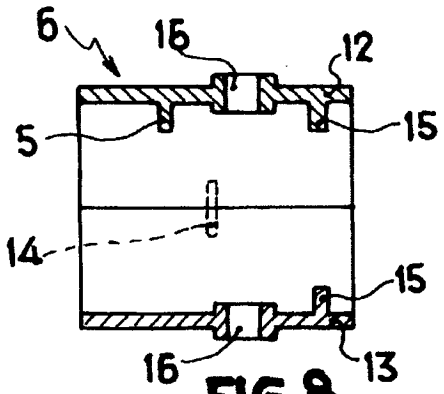

FIG. 8

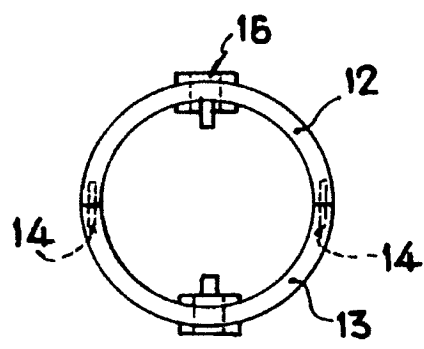

FIG. 9

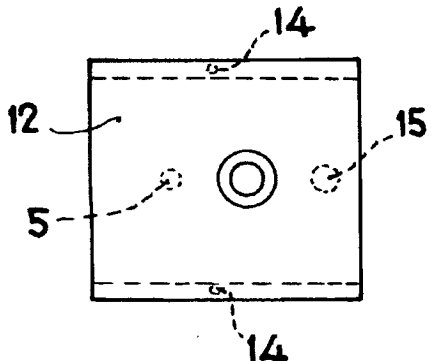

FIG. 10

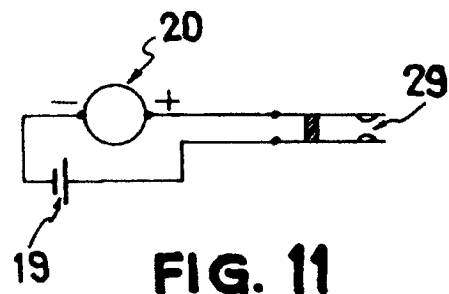

FIG. 11



DOCUMENTS CONSIDERED TO BE RELEVANT			
Category	Citation of document with indication, where appropriate, of relevant passages	Relevant to claim	CLASSIFICATION OF THE APPLICATION (Int.Cl.7)
X	US 3 115 139 A (SCHNEIDER JOHN R) 24 December 1963 (1963-12-24) * column 3, lines 5-31; figures 1,2 *	1-5	A63H33/30
X	US 2001/047189 A1 (GRIFFITH JONATHAN D) 29 November 2001 (2001-11-29) * figures 1-5 *	1-5	
X	US 5 693 073 A (GLICK ET AL) 2 December 1997 (1997-12-02) * figures 1-8 *	1-5	
A	DE 34 39 434 A1 (SCHUBERT,WERNER,DR.MED) 30 April 1986 (1986-04-30) * figures 2,4,5 *	6	
A	US 3 563 233 A (ALBERT G. BODINE) 16 February 1971 (1971-02-16) * figures 1,2 *	6	
			TECHNICAL FIELDS SEARCHED (Int.Cl.7)
			A63H A61H A63J A61J
The present search report has been drawn up for all claims			
Place of search Munich		Date of completion of the search 10 March 2005	Examiner Shmonin, V
CATEGORY OF CITED DOCUMENTS		T : theory or principle underlying the invention E : earlier patent document, but published on, or after the filing date D : document cited in the application L : document cited for other reasons & : member of the same patent family, corresponding document	
X : particularly relevant if taken alone Y : particularly relevant if combined with another document of the same category A : technological background O : non-written disclosure P : intermediate document			

1
EPO FORM 1503 03 82 (P04/C01)

**ANNEX TO THE EUROPEAN SEARCH REPORT
ON EUROPEAN PATENT APPLICATION NO.**

EP 04 38 0240

This annex lists the patent family members relating to the patent documents cited in the above-mentioned European search report. The members are as contained in the European Patent Office EDP file on
The European Patent Office is in no way liable for these particulars which are merely given for the purpose of information.

10-03-2005

Patent document cited in search report		Publication date	Patent family member(s)	Publication date
US 3115139	A	24-12-1963	NONE	

US 2001047189	A1	29-11-2001	NONE	

US 5693073	A	02-12-1997	NONE	

DE 3439434	A1	30-04-1986	NONE	

US 3563233	A	16-02-1971	NONE	

EPO FORM P0459

For more details about this annex : see Official Journal of the European Patent Office, No. 12/82