



(12) **EUROPEAN PATENT APPLICATION**

(88) Date of publication A3:
14.09.2005 Bulletin 2005/37

(51) Int Cl.7: **G07F 17/32**

(43) Date of publication A2:
15.06.2005 Bulletin 2005/24

(21) Application number: **04257693.4**

(22) Date of filing: **10.12.2004**

(84) Designated Contracting States:
**AT BE BG CH CY CZ DE DK EE ES FI FR GB GR
HU IE IS IT LI LT LU MC NL PL PT RO SE SI SK TR**
Designated Extension States:
AL BA HR LV MK YU

(72) Inventors:
• **Gerrard, Peter**
Prestwich Manchester, M25 1HN (GB)
• **Randall, Dov Liam**
Las Vegas Nevada 89134 (US)

(30) Priority: **11.12.2003 GB 0328821**
04.02.2004 GB 0402466

(74) Representative: **Wilson Gunn**
5th Floor,
Blackfriars House,
The Parsonage
Manchester M3 2JA (GB)

(71) Applicant: **IGT-UK Limited**
Lancashire OL7 0QQ (GB)

(54) **Entertainment machine**

(57) A coin-operated entertainment machine has a main display (12) which presents a card game, such as poker, or a dice game such as Poker Dice. Playing cards (26) are selected from a pack, or faces are selected from dice, and these can be changed on the display (12) using player controls (8). An award is made available if a winning card hand or dice face combination is obtained. Some winning combinations also result in transfer to an entry trail (14, 16). Play can progress from location to location (15) along the trail (14, 16) until a transfer location (17) is reached. Play can then transfer to a feature game which involves progression around a feature game trail (18, 19).

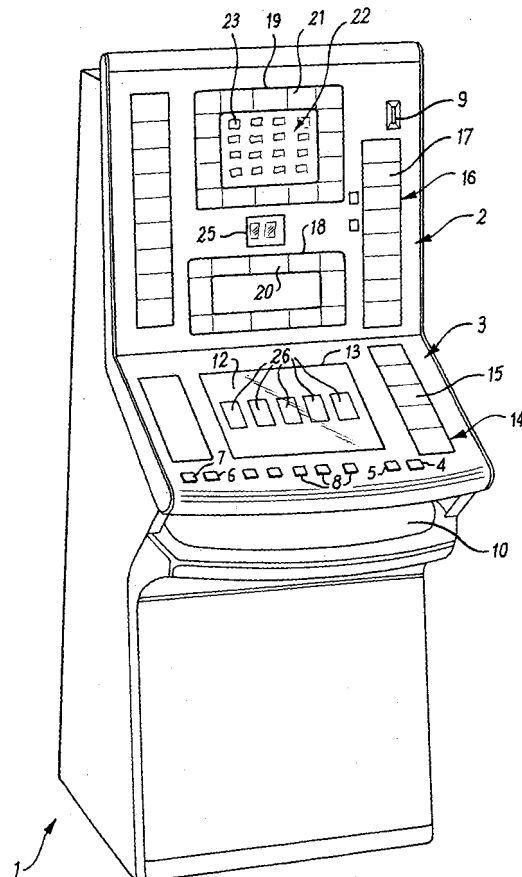

Fig. 1



DOCUMENTS CONSIDERED TO BE RELEVANT			
Category	Citation of document with indication, where appropriate, of relevant passages	Relevant to claim	CLASSIFICATION OF THE APPLICATION (Int.Cl.7)
X	WO 03/009240 A (IGT-UK LIMITED; RANDALL, DOV, LIAM) 30 January 2003 (2003-01-30) * abstract * * page 1, line 2 - page 2, line 19 * * page 9, line 4 - page 12, line 13 * * figure 1 *	1-13	G07F17/32
X	----- GB 2 374 294 A (* IGT-UK LIMITED) 16 October 2002 (2002-10-16) * abstract * * page 1, line 2 - page 3, line 7 * * page 6, line 4 - page 11, line 4 * * figures 1,2 *	1-13	
A	----- US 2002/165018 A1 (DUHAMEL GERALD) 7 November 2002 (2002-11-07) * the whole document * -----	1-13	
The present search report has been drawn up for all claims			TECHNICAL FIELDS SEARCHED (Int.Cl.7) G07F
Place of search Munich		Date of completion of the search 20 July 2005	Examiner Kling, J
<p>CATEGORY OF CITED DOCUMENTS</p> <p>X : particularly relevant if taken alone Y : particularly relevant if combined with another document of the same category A : technological background O : non-written disclosure P : intermediate document</p> <p>T : theory or principle underlying the invention E : earlier patent document, but published on, or after the filing date D : document cited in the application L : document cited for other reasons & : member of the same patent family, corresponding document</p>			

4 EPO FORM 1503 03/02 (P04C01)

**ANNEX TO THE EUROPEAN SEARCH REPORT
ON EUROPEAN PATENT APPLICATION NO.**

EP 04 25 7693

This annex lists the patent family members relating to the patent documents cited in the above-mentioned European search report.
The members are as contained in the European Patent Office EDP file on
The European Patent Office is in no way liable for these particulars which are merely given for the purpose of information.

20-07-2005

Patent document cited in search report		Publication date	Patent family member(s)	Publication date
WO 03009240	A	30-01-2003	EP 1410349 A1	21-04-2004
			WO 03009240 A1	30-01-2003
			GB 2393557 A	31-03-2004

GB 2374294	A	16-10-2002	NONE	

US 2002165018	A1	07-11-2002	US 6416406 B1	09-07-2002
			AU 2993201 A	14-08-2001
			BR 0108044 A	29-10-2002
			WO 0157816 A1	09-08-2001
			CA 2399050 A1	09-08-2001
			EP 1254440 A1	06-11-2002
