



(12) **EUROPEAN PATENT APPLICATION**

(43) Date of publication: **20.07.2005 Bulletin 2005/29** (51) Int Cl.7: **E04B 2/82, A47K 3/30**

(21) Application number: **05075075.1**

(22) Date of filing: **17.01.2005**

(84) Designated Contracting States:
**AT BE BG CH CY CZ DE DK EE ES FI FR GB GR
 HU IE IS IT LI LT LU MC NL PL PT RO SE SI SK TR**
 Designated Extension States:
AL BA HR LV MK YU

(72) Inventor: **Dunlop, Lawrence James
 Dundonald Co. Down BT16 1TQ (GB)**

(74) Representative: **Hanna, John Philip
 MacLachlan & Donaldson
 47 Merrion Square
 Dublin 2 (IE)**

(30) Priority: **16.01.2004 GB 0400950**

(71) Applicant: **Adamsez (N.I.) Limited
 Dundonald, County Down BT16 0TQ (GB)**

(54) **Vertical compensating building component**

(57) A vertical compensating building component comprises an elongate U-shaped extrusion (10) having holding means internally on each of two limbs (12). The two holding means are opposed to each other and each

is to seat a respective gripping profile (14) on the reverse of a resilient member (16), the obverse face of which has one or more outwardly-extending seats (18) having a width to provide seating against a vertical or an angled side of a panel (20) to be fitted thereto.

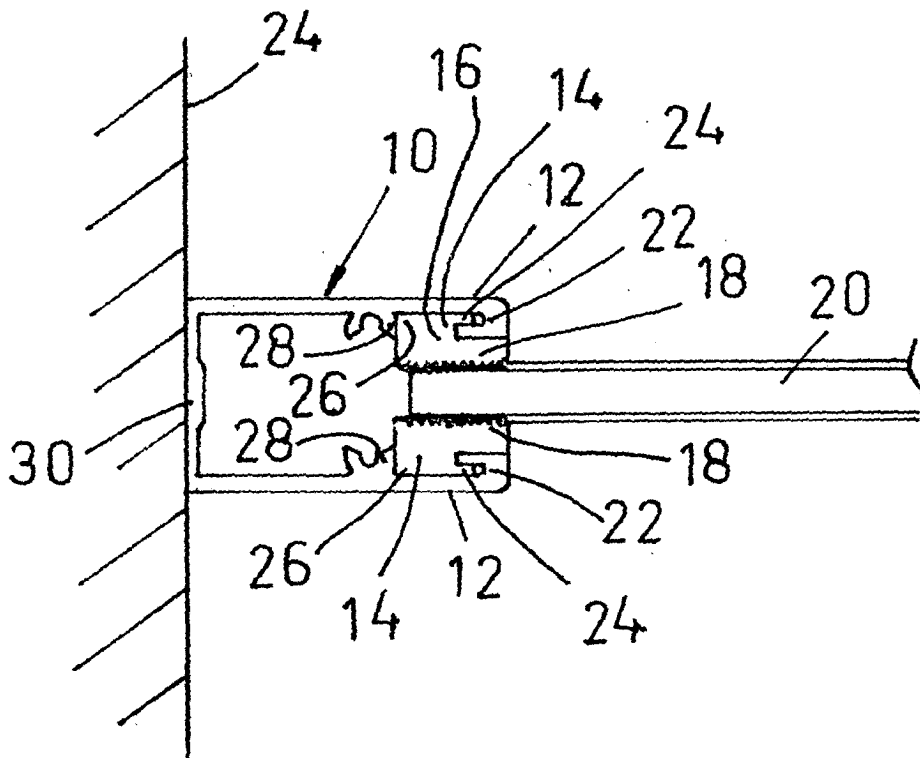

Description

[0001] This invention relates to a vertical compensating building component. Walls are normally constructed to be vertical and straight, however invariably the resulting walls constructed from building materials are off vertical and uneven. When items such as panels are to be secured against such walls, either a shaped infill member requires to be used between the wall and an upright member to which a panel is to be secured, or alternatively, one side of the panel requires to be shaped to be vertical compensating. This involves additional cost, both material cost and labour costs and therefore is disadvantageous.

[0002] A further aspect of constructed walls is that adjoining walls, while intended to be on square at ninety angular degrees to each other, are sometimes off square at a greater or lesser angle to each other. This creates a further disadvantage.

[0003] An object of the present invention is to obviate or mitigate these disadvantages.

[0004] Accordingly, the present invention is a vertical compensating building component characterised in that an elongate U-shaped extrusion intended for upright orientation has holding means internally on each of limbs, the two holding means being opposed to each other and between them holding opposed sealing surfaces to abut and provide sealing against a vertical or an angled side of a panel to be fitted thereinto.

[0005] Preferably, the opposed sealing surfaces are provided by inner surfaces of opposed limbs of a resilient element.

[0006] Preferably also, each holding means is to seat a respective gripping profile on or towards the reverse of a resilient member, the obverse face of which having one or more outwardly-extending seals forming the opposed sealing surfaces, the width of the surfaces being to provide the sealing against a vertical or an angled side of a panel to be fitted thereinto.

[0007] Preferably also, the or each seal consists of a series of spaced apart fins or serrations.

[0008] Alternatively, the or each seal is a substantially half-moon shape

[0009] Preferably further, the extrusion is provided with an internal spacing between the holding means and a web wall between the limbs to accommodate the vertical or angled side of the panel.

[0010] An embodiment of the present invention will now be described, by way of example, with reference to the accompanying drawing which shows a plan view of an extrusion of a vertical compensating building component with a panel fitted thereinto according to the present invention.

[0011] Referring to the drawing, a vertical compensating building component is intended for vertical orientation. The component comprises an elongate U-shaped extrusion 10 having holding means internally on each of two limbs 12. The two holding means are opposed to

each other and each is to seat a respective gripping profile 14 on or towards the reverse of a resilient member 16. Each holding means comprises the outer end of each limb 12 being reflexively bent inwardly as shown to define a channel 22 to receive a tongue 24 of the resilient member 16. The reverse of the profile 14 has a tongue 24 at one end and has a square end 26 as shown at the opposite end to seat against an inwardly extending ridge 28. The obverse face of each element 16 has one outwardly-extending seal 18. The outwardly-extending seals 18 form opposed sealing surfaces and each has a width to provide sealing against a vertical or an angled side of a panel 20 to be fitted thereinto.

[0012] The seals 18 each consist of a series of spaced apart fins or serrations or alternatively the seals may be of substantially half moon shape.

[0013] A waterproof edging is provided to be between the respective panel 20 and the outer edges of the limbs 12 of the extrusion 10.

[0014] The extrusion 10 may be of aluminium alloy or plastics material and the resilient members 16 may be of artificial rubber or material having similar resilient and waterproof characteristics. If plastics material is used, it may be provided with an aluminium foil outer skin.

[0015] A compressible element is normally used on the wall side of the infill or upright member to fill in the unevenness in the wall to which it is fitted.

[0016] After the panel is fitted, a piece of thin rubber sheeting (not shown) is placed over the top of the panel 20 adjacent to the top of the extrusion 10 and a cap (not shown) is fitted and secured to the extrusion 10 and an integral cap extension overlies the sheeting and has two downwardly-extending elements which forces the sheeting to abut against the sides of the panel 20 and provide a locking grip between the extrusion 10 and the panel 20.

[0017] The extrusion 10 is provided with an internal spacing between the holding means and a web wall 30 between the limbs 12 to accommodate the vertical or angled side of the panel 20.

[0018] In use, a component is fixed to a wall 24 irrespective of whether the wall is vertical or off vertical and one straight edge of a panel 20 is then located in the extrusion 10 between the seals 18. The opposite edge of the panel 20 is made vertical using a spirit level or equivalent. If the wall is vertical then the straight edge in between the seals is vertical, however if the wall is off vertical then the straight edge in the seals 18 is angled in the seals 18. The width of the seals and the internal spacing provides the vertical compensation so that no additional infill parts are required and no shaping of the panel is required and as claimed hereinafter.

[0019] In a simplified embodiment (not shown) the opposed sealing surfaces are provided by the inner surfaces of opposed limbs of a resilient element being a thin sheet of foam material. Any edges of the foam material extending beyond the limbs of the extrusion being trimmed in line with the extrusion to present a neat ap-

pearance.

[0020] Variations and modifications can be made without departing from the scope of the invention described above as claimed hereinafter.

5

Claims

1. A vertical compensating building component **characterised in that** an elongate U-shaped extrusion (10) intended for upright orientation has holding means internally on each of limbs (12), the two holding means being opposed to each other and between them holding opposed seating surfaces to abut and provide sealing against a vertical or an angled side of a panel (20) to be fitted thereinto. 10
15
2. A vertical compensating building component as claimed in Claim 1, **characterised in that** the opposed sealing surfaces are provided by inner surfaces of opposed limbs of a resilient element. 20
3. A vertical compensating building component as claimed in Claim 1, **characterised in that** each holding means is to seat a respective gripping profile (14) on the reverse of a resilient member (16), the obverse face of which having one or more outwardly-extending seals (18) forming the opposed sealing surfaces, the width of the seals (18) being to provide the seating against a vertical or an angled side of a panel (20) to be fitted thereinto. 25
30
4. A vertical compensating building component as claimed in Claim 3, **characterised in that** the or each seal (18) consists of a series of spaced apart fins or serrations. 35
5. A vertical compensating building component as claimed in Claim 3, **characterised in that** the or each seal is of substantially half-moon shape. 40
6. A vertical compensating building component as claimed in anyone of the preceding Claims, **characterised in that**, the extrusion (10) is provided with an internal spacing between the holding means and a web wall (30) between the limbs (12) to accommodate the vertical or angled side of the panel (20). 45

50

55



DOCUMENTS CONSIDERED TO BE RELEVANT			
Category	Citation of document with indication, where appropriate, of relevant passages	Relevant to claim	CLASSIFICATION OF THE APPLICATION (Int.Cl.7)
X	EP 0 876 788 A (DORMA GMBH + CO. KG) 11 November 1998 (1998-11-11)	1-3,6	E04B2/82 A47K3/30
Y	* figures 1,4 *	4,5	

X	WO 93/05261 A (KENDON INDUSTRIES PTY. LTD) 18 March 1993 (1993-03-18) * figures 6,26 *	1-3,6	

Y	GB 2 352 262 A (* EPWIN GROUP PLC; * EPWIN PROPERTY HOLDINGS LIMITED) 24 January 2001 (2001-01-24) * figure 2 *	4,5	

			TECHNICAL FIELDS SEARCHED (Int.Cl.7)
			E04B A47K
The present search report has been drawn up for all claims			
Place of search		Date of completion of the search	Examiner
Munich		11 March 2005	Rosborough, J
CATEGORY OF CITED DOCUMENTS			
X : particularly relevant if taken alone Y : particularly relevant if combined with another document of the same category A : technological background O : non-written disclosure P : intermediate document T : theory or principle underlying the invention E : earlier patent document, but published on, or after the filing date D : document cited in the application L : document cited for other reasons & : member of the same patent family, corresponding document			

1
EPO FORM 1503 03.82 (P04/C01)

**ANNEX TO THE EUROPEAN SEARCH REPORT
ON EUROPEAN PATENT APPLICATION NO.**

EP 05 07 5075

This annex lists the patent family members relating to the patent documents cited in the above-mentioned European search report. The members are as contained in the European Patent Office EDP file on The European Patent Office is in no way liable for these particulars which are merely given for the purpose of information.

11-03-2005

Patent document cited in search report		Publication date	Patent family member(s)	Publication date
EP 0876788	A	11-11-1998	DE 19719013 A1	12-11-1998
			DE 29724645 U1	08-08-2002
			EP 0876788 A2	11-11-1998

WO 9305261	A	18-03-1993	AU 656024 B2	19-01-1995
			WO 9305261 A1	18-03-1993
			CN 1075622 A	01-09-1993

GB 2352262	A	24-01-2001	NONE	

EPO FORM P0459

For more details about this annex : see Official Journal of the European Patent Office, No. 12/82