



Europäisches Patentamt
European Patent Office
Office européen des brevets



(11) **EP 1 561 426 A8**

(12) **CORRECTED EUROPEAN PATENT APPLICATION**

Note: Bibliography reflects the latest situation

(15) Correction information:
Corrected version no 1 (W1 A1)
INID code(s) 71

(51) Int Cl.7: **A61B 17/00, A61B 18/14**

(48) Corrigendum issued on:
09.11.2005 Bulletin 2005/45

(43) Date of publication:
10.08.2005 Bulletin 2005/32

(21) Application number: **05002142.7**

(22) Date of filing: **02.02.2005**

(84) Designated Contracting States:
**AT BE BG CH CY CZ DE DK EE ES FI FR GB GR
HU IE IS IT LI LT LU MC NL PL PT RO SE SI SK TR**
Designated Extension States:
AL BA HR LV MK YU

(72) Inventor: **Dycus, Sean T.**
Denver Colorado 80205 (US)

(74) Representative: **HOFFMANN EITL**
Patent- und Rechtsanwälte
Arabellastrasse 4
81925 München (DE)

(30) Priority: **03.02.2004 US 770982**

(71) Applicant: **Sherwood Services AG**
8200 Schaffhausen (CH)

(54) **Arterial hole closure apparatus**

(57) A closure device for use following various surgical procedures to close access openings through the tissue wall while permitting post operative flow through the tissue conduit includes a housing having proximal and distal ends, and defining a longitudinal axis, first and second tissue everting members mounted adjacent the distal end of the housing and first and second jaw members mounted adjacent the first and second tissue engaging members. The first and second arterial tissue everting members are dimensioned for at least partial positioning within the access opening in the tissue wall and are deployable in at least a radial outward direction relative to the longitudinal axis of the housing to engage respective opposed tissue portions on opposed sides of the opening and move the tissue portions to an everted condition thereof. The first and second jaw members are adapted for relative movement between an open position to facilitate positioning about the tissue portions in the everted condition and a closed position to at least partially draw the tissue portions together to an at least partial approximated condition. Electrodes are associated with the first and second jaw members and arranged to contact the respective tissue portions. The electrodes are adapted to be connected to a radiofrequency energy source whereby energy is transmitted through the electrode to seal the tissue positions be-

tween the first and second jaw members to substantially close the opening.

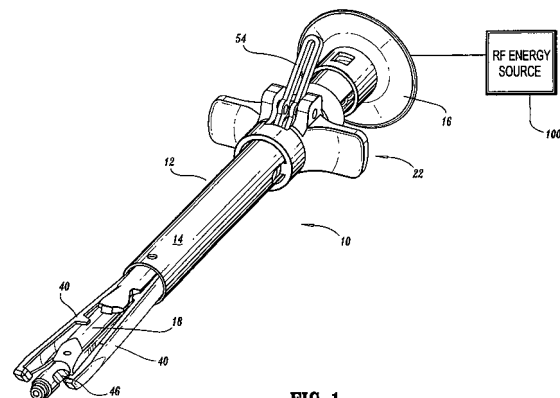

FIG. 1

EP 1 561 426 A8