



Europäisches Patentamt
European Patent Office
Office européen des brevets



(11) **EP 1 564 174 A1**

(12) **EUROPEAN PATENT APPLICATION**
published in accordance with Art. 158(3) EPC

(43) Date of publication:
17.08.2005 Bulletin 2005/33

(21) Application number: **03772824.3**

(22) Date of filing: **17.11.2003**

(51) Int Cl.7: **B65H 75/40**

(86) International application number:
PCT/JP2003/014588

(87) International publication number:
WO 2004/048242 (10.06.2004 Gazette 2004/24)

(84) Designated Contracting States:
**AT BE BG CH CY CZ DE DK EE ES FI FR GB GR
HU IE IT LI LU MC NL PT RO SE SI SK TR**
Designated Extension States:
AL LT LV MK

(30) Priority: **22.11.2002 JP 2002338919**
14.02.2003 JP 2003036352
14.03.2003 JP 2003070299
14.08.2003 JP 2003293377
14.08.2003 JP 2003293376

(71) Applicant: **Iris Ohyama, Inc.**
Sendai-shi, Miyagi-ken 980-8510 (JP)

(72) Inventor: **TANJI, H.,**
c/o KAKUDA PLANT, IRIS OHYAMA, INC.
Kakuda-shi, Miyagi 981-1 596 (JP)

(74) Representative: **Hallybone, Huw George et al**
Carpmaels and Ransford,
43-45 Bloomsbury Square
London WC1A 2RA (GB)

(54) **HOSE REEL**

(57) This is a hose reel for winding up a hose. The invention provides a hose reel capable of neatly winding up a hose. The frame of a hose reel 1 is configured of a body case 11, and the drum for winding up the hose is rotatably supported in the body case 11. A guide part 32 for guiding the hose is disposed on the moving path of the hose to be wound up by the drum, the path being the front face 31 of the upper vessel 13 of the body case 11. The guide part 32 is provided with an inlet/outlet 33 through which the hose is inserted, and the upper opening edge of the inlet/outlet 33 constitutes an upper restrictive part 34 to obstruct the hose from escaping upward. The upper restrictive part 34 extends in a direction crossing the moving direction I of the hose to be wound, and forms an arch shape whose central part protrudes upward.

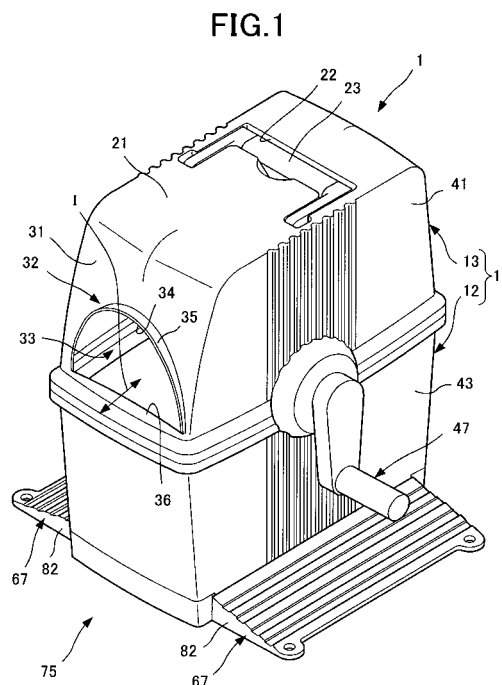

EP 1 564 174 A1

Description

Technical Field

[0001] The present invention relates to a hose reel for winding up a hose.

Background Art

[0002] Conventionally, a hose reel is used for winding up a hose for sprinkling use (see for instance Japanese Patent Laid-Open No. 2001-206637 (FIG. 1) and Japanese Patent Laid-Open No. 2001-206638 (FIG. 1)).

[0003] This hose reel would be composed of a frame and a drum rotatably supported by the frame. The frame consists of triangular side plates disposed opposite each other, and the two side plates are linked with a space between them. A connecting plug for connecting the faucet side hose protrudes from one of these side plates, and a handle for turning the drum protrudes from the other.

[0004] It is so configured as to wind up and keep the hose around the drum by turning this handle.

[0005] However, as the side plates constituting the frame are disposed with a space between them in this hose reel, the hose winding side is open. As a result, the hose wound around the drum is apt to become disorderly in the wound state.

[0006] Also, there is another type of hose reel consisting of a frame and a drum rotatably supported by the frame, and the frame consists of right and left side plates and pipe members linking the two side plates.

[0007] Further, the drum is formed of a barrel around which the hose is to be wound and collars disposed at the two ends of the barrel.

[0008] However, as the hose winding side is open in this hose reel, the hose is apt to be wound into the gap between the drum and the frame.

[0009] A hose can be neatly wound by neither of these conventional hose reels. An object of the present invention, attempted in view of these problems with the conventional reels, is to provide a hose reel that can neatly wind up a hose.

Disclosure of the Invention

[0010] In order to solve the problem noted above, a hose reel according to Claim 1 of the present invention is a hose reel for winding a hose by turning a drum, wherein a guide part for guiding the hose is provided on the moving path of the hose to be wound around the drum and the width of the guide part is so set as to decrease toward its upper portion.

[0011] Thus, when the hose is wound by turning the drum, the hose may sometimes concentrate on one end of the drum. However, the guide part for guiding the hose is provided on the moving path of the hose, and the width of the guide part is so set as to decrease toward its upper

portion.

[0012] As a result, the hose wound concentrating on an end of the drum is guided along the guide part toward the central part when a prescribed quantity has been wound up.

[0013] A hose reel according to Claim 2 of the invention is a hose reel for winding a hose by turning a drum, wherein a guide part for guiding the hose is provided on the moving path of the hose to be wound around the drum, a restrictive part for preventing the hose from escaping is extended on the guide part in a direction crossing the moving direction of the hose, an inclined part inclined toward the central part along its upper direction is set on the restrictive part, and the angle of inclination in the inclined part is set to be not less than 45 degrees and less than 90 degrees.

[0014] Thus, when the hose is wound by turning the drum, the hose may sometimes concentrate on one end of the drum. However, the guide part for guiding the hose is provided on the moving path of the hose, and an inclined part inclined toward the central part along its upper direction is set on the restrictive part set on the guide part.

[0015] As a result, the hose wound concentrating on an end of the drum is guided by the inclined part toward the central part when a prescribed quantity has been wound up.

[0016] Then, a downward component of force and a horizontal component of force arise in the hose that has come into contact with this inclined part, and the angle of inclination of the inclined part is set to be not less than 45 degrees and less than 90 degrees. For this reason, the horizontal component of force is not less than the downward component of force, and the force guiding the hose stacked to a prescribed quantity toward the central part is not less than the force pressing the hose downward.

[0017] Further, a hose reel according to Claim 3 of the invention is a hose reel for winding a hose by turning a drum, wherein a guide part for guiding the hose is provided on the moving path of the hose to be wound around the drum, a restrictive part for preventing the hose from escaping is extended on the guide part in a direction crossing the moving direction of the hose, and the restrictive part is formed in an arc shape whose central part protrudes.

[0018] Thus, when the hose is wound by turning the drum, the hose may sometimes concentrate on one end of the drum. However, the guide part for guiding the hose is provided on the moving path of the hose, and the restrictive part set on the guide part is formed in an arc shape whose central part protrudes.

[0019] As a result, the hose wound concentrating on an end of the drum is guided along the guide part in an arc shape toward the central part when a prescribed quantity has been wound up.

[0020] Further, in a hose reel according to Claim 4 of the invention, an opening through which the hose is in-

serted is provided in the guide part, the restrictive part is set in the upper opening edge of the opening, and the lower opening edge of the opening is linearly formed.

[0021] Thus, of starting winding of the hose around an empty drum, the hose to be moved is guided along the lower opening edge of the opening in the guide part. In this arrangement this lower opening edge is linearly formed. As a result, the hose is wound around the whole area of the drum in a distributed way.

[0022] And when a prescribed quantity of the hose has been wound up around the drum, it is guided along the restrictive part formed by the upper opening edge of the opening in the guide part.

[0023] Further in a hose reel according to Claim 5 of the invention, the drum is supported by a frame, and the guide part is composed of a bar disposed on the frame.

[0024] This contributes to simplification of the configuration.

[0025] Further in a hose reel according to Claim 6 of the invention is a hose reel for winding a hose by turning a drum, wherein a guide part having an opening through which the hose is inserted is provided on the moving path of the hose to be wound around the drum, and a thick part thicker than a general part is disposed on the opening edge of the opening.

[0026] Thus, the hose to be wound up by the drum is guided to its prescribed position by being inserted through the opening disposed in the guide part and brought into sliding contact with the opening edge of the opening.

[0027] Herein, a thick part thicker than a general part is disposed on the opening edge of the opening. As a result, inadvertent bending of the hose can be more securely prevented than in a case in which the opening edge is composed of a thin part.

[0028] Further, a hose reel according to Claim 7 of the invention is a hose reel for winding a hose by turning a drum, wherein a guide part having an opening through which the hose is inserted is provided on the moving path of the hose to be wound around the drum, and the sectional shape of the opening edge of the opening is formed in an arc protruding toward the center of the opening.

[0029] Thus, the hose to be wound up by the drum is guided to its prescribed position by being inserted through the opening disposed in the guide part and brought into sliding contact with the opening edge of the opening.

[0030] Herein, the opening edge of the opening is formed in an arc having a sectional shape protruding toward the center of the opening. As a result, the area of contact with the hose in sliding contact is reduced.

[0031] In addition, a hose reel according to Claim 8 of the invention is a hose reel for winding a hose by turning a drum, wherein a rotational member in contact with the hose and rotating in the direction of urging the movement of the hose is disposed on the moving path of the hose to be wound up by the drum.

[0032] Thus, the hose to be wound up by the drum comes into contact with the rotational member disposed on the moving path of the hose. This rotational member is in contact with the hose and rotates in the direction of urging the movement of the hose. In this way, the hose is guided by the rotational member to the drum.

[0033] And in a hose reel according to Claim 8 of the invention the outer circumferential face of the hose is made rugged.

[0034] Thus, when the hose is wound up, the outer circumferential face of the hose comes into sliding contact with the inner face of the drum or that of the frame and gives rise to friction. However, as the outer circumferential face of this hose is rugged, the frictional resistance to the area of sliding contact is reduced. The winding of the hose around the drum is further smoothed, and disorderly winding is prevented.

[0035] Further in a hose reel according to Claim 10 of the invention wherein a drum having collars at the two ends of its barrel is turnably supported by a frame, the frame is formed in a shape allowing accommodation of the drum, an inlet/outlet for the hose is disposed in a position in the frame opposite the winding position between the two collars of the drum, and the width of the inlet/outlet is set to be not greater than the distance from one collar of the drum to the other.

[0036] Thus, the inlet/outlet for the hose is disposed in the position in the frame opposite the winding position between the two collars of the drum, and the hose to be wound up by the drum moves via this inlet/outlet.

[0037] And the width of this inlet/outlet is set to be not greater than the distance from one collar of the drum to the other. As a result, the hose to be accommodated into the frame via the inlet/outlet is guided to the position between the two collars of the drum.

[0038] Further in a hose reel according to Claim 11 of the invention, the frame is formed in a case shape for accommodating the drum.

[0039] Thus, the frame turnably supporting the drum is formed in the case shape allowing accommodation of the drum, the inlet/outlet for the hose is disposed in the position in the frame opposite the winding position between the two collars of the drum, and the hose to be wound up by the drum moves via this inlet/outlet.

[0040] And the width of the inlet/outlet is set to be not greater than the distance from one collar of the drum to the other. As a result, the hose accommodated into the frame via the inlet/outlet is guided to the position between the two collars of the drum.

[0041] Further in a hose reel according to Claim 12 of the invention, the width of the inlet/outlet is set to decrease toward the upper part.

[0042] Preferably, as stated in Claim 13 of the invention, the opening edge of the inlet/outlet on the upper side should be formed in an arc shape whose central part protrudes upward.

[0043] Thus, when the hose is wound by turning the drum, the hose may sometimes concentrate on the col-

lar at one end of the drum. However, as the width of the inlet/outlet through which the hose moves is set to decrease toward the upper part, and preferably the opening edge of the inlet/outlet on the upper side is formed in an arc shape whose central part protrudes upward.

[0044] As a result, the hose wound concentrating on the end of the drum is guided along the opening edge of the inlet/outlet, preferably along an opening edge in the arc shape, toward the central part when a prescribed quantity has been wound up.

[0045] In addition, in a hose reel according to Claim 14 of the invention, the starting point of the arc shape of the opening edge is set between the center of rotation of the drum and the highest position of the collars.

[0046] As a result, the hose to be wound concentrating on the collars side of the end of the drum, before reaching the highest position of the collars, is guided toward the central part along the opening edge of the arc shape.

[0047] Further in a hose reel according to Claim 15 of the invention, a drum having collars at the two ends of its barrel is turnably supported by a frame, the distance between the two collars is set between 40% and 60% of the diameter of the collars.

[0048] Thus, the distance between the two collars provided at the two ends of the barrel of the drum around which the hose is to be wound is set between 40% and 60% of the diameter of the collars. When the hose is wound around such a drum, even if the hose is wound concentrating on one of the collars, a collapse will arise within. For this reason, the hose is guided to a position between the two collars by being wound around this drum.

[0049] Herein, though the winding ease of the hose can be improved by reducing the distance between the collars of the drum, but if the distance between the collars is made too small, the drum will become thin and apt to fall down. In view of this factor, repeated experiments have led to a discovery that the two requirements can be made consistent with each other by setting the distance between the collars of the drum to between 40% and 60% of the diameter of the collars.

[0050] As a result, the invention according to which the distance between the collars of the drum is set to between 40% and 60% of the diameter of the collars enables the winding ease to be improved without sacrificing the resistance of the drum to falling down.

Brief Description of the Drawings

[0051]

FIG. 1 shows a perspective view of a first mode for implementing the present invention. FIG. 2 shows a profile of the same embodiment. FIG. 3 shows a section along line A-A in FIG. 2. FIG. 4 shows a plan of the same embodiment. FIG. 5 shows a section along line B-B in FIG. 4. FIG. 6 shows a front view

of the same embodiment. FIG. 7 shows a bottom view of the same embodiment. FIG. 8 is a diagram corresponding to section C-C in FIG. 4. FIG. 9 shows a section of the essential part in the same embodiment in a folded state. FIG. 10 shows a perspective view of a second mode for implementing the invention. FIG. 11 shows a perspective view of a third mode for implementing the invention. FIG. 12 shows a section of a hose in the essential part in the same embodiment. FIGS. 13 show a perspective view in 13A and a profile in 13B of a fourth mode for implementing the invention. FIGS. 14 show a fifth mode in 14A, a sixth mode in 14B, and a seventh mode for implementing the invention in 14C. FIG. 15 shows an eighth mode for implementing the invention. FIG. 16 shows a perspective view of a ninth mode for implementing the invention. FIG. 17 shows a profile of the same embodiment. FIG. 18 shows a section along line D-D in FIG. 17. FIG. 19 shows a section of a hose in the same embodiment. FIG. 20 shows a plan of the same embodiment. FIG. 21 shows a section along line E-E in FIG. 20. FIG. 22 shows a front view of the same embodiment. FIG. 23 shows a bottom view of the same embodiment. FIG. 24 is a diagram corresponding to section F-F in FIG. 20. FIG. 25 shows a section of the essential part in the same embodiment in a folded state. FIG. 26 shows a variation of the same embodiment. FIGS. 27 show another variation of the same embodiment. FIGS. 28 show still another variation of the same embodiment.

Best Modes for Carrying Out the Invention

[0052] The present invention will be described in more detail with reference to the accompanying drawings.

(First Embodiment)

[0053] A first mode for implementing the invention will be described below with reference to drawings. FIG. 1 shows a hose reel 1 in this embodiment, the hose reel 1 being intended for use in winding up a hose for the sprinkling purpose.

[0054] This hose reel 1 is provided with a rectangular body case 11 constituting a frame, and the body case 11 as shown in FIG. 2, formed by coupling a lower vessel 12 of a container shape opening upward and an upper vessel 13 of a container shape opening downward. This body case 11, as shown in FIG. 3, accommodates a drum 15 for winding up a hose 14, and the drum 15 comprises a cylindrical barrel 17 around which the hose 14 having penetrated a hose inserting hole 16 is wound and collars 18 and 18 disposed at the two ends of the barrel 17.

[0055] The top plate 21 of the upper vessel 13, as shown in FIG. 1 and FIG. 4, is formed in a rectangular flat shape. The top plate 21, set to be large enough to

permit the mounting of another hose reel on the body case 11, constitutes a load carrier.

[0056] A C-shaped concave 22 is formed in this top plate 21, and a C-shaped handle 23 is arranged in the concave 22. The handle 23 is composed of a grip 24 constituting a free end and extension parts 25 and 25 extending from the two ends of the grip 24 into the C shape, and turnably supported by the upper vessel 13 via rotation shafts 26 and 26 disposed at the tips of the extension parts 25 and 25 as shown in FIG. 5. In this way, the handle 23 is so configured as to be turnable between an inclined state 27 in which it is accommodated in the concave 22 and an erect state 28 in which it is erect.

[0057] These extension parts 25 and 25 of the handle 23 are so configured that its turning is restricted as it comes into contact, in its erect state 28, with a contact part 29 consisting of the upper edge of the concave 22, and the contact part 29 is composed of an inclined face which inclined forward. The handle 23 is so configured that, in this erect state 28, its turning is restricted at a prescribed angle α beyond 90 degrees, more specifically 109 degrees from the inclined state 27. By virtue of this arrangement, when the handle 23 in the inclined state 27 is to be shifted to the erect state 28, after the grip 24 constituting the free end of the handle 23 passes above the center of turning consisting of the rotation shafts 26, the extension parts 25 and 25 stop in a forward incline state in contact with the contact part 29.

[0058] On the moving path of the hose 14 wound up by the drum 15, the path being the front face 31 of the upper vessel 13, a guide part 32 for guiding the hose 14 is disposed as shown in FIG. 6. The guide part 32 is provided with an inlet/outlet 33 as an opening through which the hose 14 is inserted, and the upper opening edge of the inlet/outlet 33 constitutes an upper restrictive part 34 to prevent the hose 14 from escaping upward. The upper restrictive part 34 extends in a direction crossing the moving direction l of the hose 14 that is wound up (see FIG. 1), and the upper restrictive part 34 is formed in an arch shape, protruding upward in its central part.

[0059] Incidentally, although the guide part according to the invention is configured by forming the inlet/outlet 33 in the front face 31 in this embodiment, this guide part can as well be formed by cutting a notch downward in the lower edge of a plate-shaped member or configured of a pipe formed in an angle or trapezoidal shape.

[0060] The upper restrictive part 34 is so set that the width W of the lower side hose passage formed by the upper restrictive part 34 is thereby set to become smaller toward the upper part.

[0061] To add, though the example described above is a case in which the upper restrictive part 34 is formed of the upper opening edge of the inlet/outlet 33, this is not the only possibility, but it may be configured of a long member curved in an arch shape.

[0062] Also, the lower opening edge of the inlet/outlet

33 may as well be open.

[0063] A bottom 35 is formed throughout the area of this upper restrictive part 34 as shown in FIG. 5, and the bottom 35 protrudes outward from the body case 11.

5 The position of the upper restrictive part 34 in its highest area is set to be lower than the highest area in the collars 18 of the drum 15 supported by the body case 11, and an allowance Y for hose winding is set between the highest area in the upper restrictive part 34 and the highest area in the collars 18.

10 **[0064]** The lower opening edge of the inlet/outlet 33, as shown in FIG. 6, is linearly formed to constitute a lower restrictive part 36 to allow the hose 14 to move in the lateral direction. The inlet/outlet 33 is thereby formed in a semicircular shape whose arch-shaped part is positioned at the top.

15 **[0065]** The lower restrictive part 36 constituting the opening edge of the inlet/outlet 33 is formed thicker than the general part 37 as shown in FIG. 5 to constitute a thick part 38. This thick part 38 is arch-shaped in sectional shape, protruding toward the center of the inlet/outlet 33, and is so configured that the hose 14 moving within the inlet/outlet 33 come into line contact with it.

20 **[0066]** At the joints between the lower ends of the left and right sides 41 and 42 of this upper vessel 13 and the upper ends of the left and right sides 43 and 44 of the lower vessel 12, there are formed bulgy parts 45 and 45 bulging sideways, which constitute a circular form when joined together, as shown in FIG. 1 and FIG. 6, and end parts of the barrel 17, protruding from the collars 18 and 18 of the drum 15, are rotatably supported between the bulgy parts 45 and 45 as shown in FIG. 3. Round holes 46 and 46 are provided at the centers of these bulgy parts 45 and 45, and the shaft 48 of a crank-shaped handle 47 for turning the drum 15 is inserted into the round hole 46 of the bulgy part 45 arranged on the left side.

25 **[0067]** Also, a connecting plug 51 for connecting the faucet side hose is inserted into the round hole 46 of the bulgy part 45 arranged on the right side, and one end of a pipe member 52 to be connected to the hose 14 wound around the drum 15 is connected to the connecting plug 51. This configuration enables running water from the faucet to be supplied to the pipe member 52 via the connecting plug 51 and to the hose 14 on the sprinkling side, wound around the drum 15, via the pipe member 52.

30 **[0068]** A rectangular bottom opening 62 is cut in the bottom 61 of the lower vessel 12 as shown in FIG. 7, and the body case 11 communicates with outside via this bottom opening 62.

35 **[0069]** Laterally long leg-fixing members 65 and 65 are screwed on along the edges of the front and rear face sides of the bottom 61. Cross-shaped shafts 66 and 66 protrude in mutually opposite direction at the two ends of the leg fixing members 65 and 65 as shown in FIG. 8, and legs 67 and 67 formed in the same shape are rotatably supported by the opposite shafts 66 and 66.

[0070] At both ends of these legs 67, cylindrical parts 71 and 71 to externally fit onto the shafts 66 and 66 are formed in base ends 72, and top face parts 73 extending toward the tips are integrally formed with these cylindrical parts 71. The legs 67 and 67 are so configured as to be able to form as desired by turning around the cylindrical parts 71 and 71 a folded state 74 in which, as shown in FIG. 9, the tips of both legs 67 and 67 are arranged underneath the body case 11 and both legs 67 and 67 are arranged underneath the bottom opening 62 or a developed state 75 in which, as shown in FIG. 1, the tips of both legs 67 and 67 extend sideways from the body case 11 and are in contact with the bottom 61 of the body case 11 (see FIG. 8) to be restricted in turning.

[0071] The configuration is such that the erect state of the body case 11 can be thereby stabilized in the developed state 75 and, in the folded state 74, the bottom opening 62 cut in the bottom 61 can be closed by the legs 67 and 67.

[0072] The top face parts 73 are formed in such lengths that, when one leg 67 is folded ahead of the other leg 67 to constitute the folded state 74 shown in FIG. 9, the parts of the two legs 67 and 67 farther out than the base ends 72 and 72 overlap each other, and on their rear faces a plurality of the ribs 81, ... and flanges 82 and 82 extending from their two side edges are integrally formed. The heights of these flanges 82 and 82 and the ribs 81, ... are set to become lower from the base ends 72 toward the tips as shown in FIG. 8, and the thickness of each leg 67 is set to become thinner from the base ends 72 pivoting on the body case 11 toward the tip.

[0073] Further, the thickness of the legs 67 and 67 in their overlapping parts 83, as shown in FIG. 9, is so set that the sum of their thickness counts overlapping each other in the folded state 74 be not greater than the greatest thickness of the legs 67 and 67, i.e. at the base ends 72, resulting in a configuration in which the legs 67 and 67 are positioned above the under faces of the leg fixing members 65 in the folded state 74.

[0074] And as shown in FIG. 5, two ribs 92 and 92 extend from the bottom 61 toward the upper opening on an inner side face 91 of the lower vessel 12 of the body case 11, and two ribs 94 and 94 also extend from the top plate 21 toward the lower opening on an inner side face 93 of the upper vessel 13 of the body case 11. Thus, these ribs 92, 92, 94 and 94 extend in the direction of mold drawing when the vessels 12 and 13 are molded of resin.

[0075] The heights H of the ribs 92, 92, 94 and 94, as shown in FIG. 3, are set to be not less than the separation distance R from each of the inner side faces 91 and 93 to the collars 18 of the drum 15, the lengths of the ribs 92, 92, 94 and 94, as shown in FIG. 5, are so set as to bring their tips close to the collars 18.

[0076] In this embodiment using the configuration described above, when the hose 14 is to be wound up by

turning the drum 15 with the handle 47, the hose 14 may sometimes concentrate on one end of the drum 15, i. e. on the side of one of the collars 18. However, the guide part 32 for guiding the hose 14 is disposed on the moving path of the hose 14, and the central part of the upper restrictive part 34 set on the guide part 32 has an arch-shaped bulging upward. In other words, the width W of the passage for the hose 14 formed underneath the upper restrictive part 34 is so set as to decrease upward.

[0077] For this reason, when the hose 14 wound concentrating around an end of the drum 15 reaches a prescribed height, the hose 14 can be guided toward the central part along the upper restrictive part 34 in the arch-shaped whose the width W decreases upward.

[0078] Therefore, it is possible to prevent disorderly winding of the hose 14, its concentration around one end of the drum 15 and to wind up the hose 14 neatly. This also contributes to improve the appearance of the wound state of the hose and to prevent deviation of the center of gravity.

[0079] On the other hand, at the time of starting winding of the hose 14 around an empty drum 15, around which no hose 14 is wound yet, it is possible to guide this hose 14 along the lower restrictive part 36 formed by the lower opening edge of the inlet/outlet 33 in the guide part 32.

[0080] This lower restrictive part 36 here is linearly formed, and allows the hose 14, guided in sliding contact with the lower restrictive part 36, to move in the lateral direction and the hose 14 to be wound around the whole area of the drum 15 in a distributed way. This enables disorderly winding at the start of winding to be prevented.

[0081] And from the time a prescribed quantity of the hose 14 has been wound around the drum 15, the hose 14 can be guided along the upper restrictive part 34 formed by the upper opening edge of the inlet/outlet 33 in the guide part 32. The above-described effect can be thereby achieved.

[0082] In this way, by bringing the hose 14 penetrating the inlet/outlet 33 in sliding contact with opening edge of the inlet/outlet 33, it can be guided to its prescribed position. Therefore, compared with a case in which the hose 14 to be wound around the drum 15 is not guided, disorderly winding of the hose 14 can be prevented, with the result that the appearance of the wound state of the hose can be improved and deviation of the center of gravity due to disorderly winding can be prevented.

[0083] In this configuration, the thick part 38 thicker than the general part 37 is set for the lower restrictive part 36 constituting the opening edge of the inlet/outlet 33. For this reason, inadvertent bending of the hose 14 can be more securely prevented than in a case in which the opening edge is composed of a thin part, resulting in improved ease of winding.

[0084] Furthermore, the section of the thick part 38 of the lower restrictive part 36 is formed in an arc shape, protruding toward the center of the inlet/outlet 33. As a

result, its area of sliding contact with the hose 14 can be reduced, making it possible to restrain the frictional resistance that arises at the time of winding. Therefore, the winding of the hose 14 can be facilitated.

(Second Embodiment)

[0085] FIG. 10 shows a second embodiment, wherein parts having exact or equivalent counterparts in the above-described embodiment are denoted by respectively the same signs, their description being dispensed with.

[0086] Thus, a roller 101 as a columnar rotational member is disposed on the lower opening edge of the linearly formed inlet/outlet 33. The shaft 102 extending from the two ends of this roller 101 is rotatably supported by the bottom 35, with its ends inserted into the two lower ends of the bottom, and is so configured as to rotate in the direction of urging the movement of the hose 14 when it comes into contact with the hose 14 moving through the inlet/outlet 33.

[0087] This enables the hose 14 wound up by the drum 15 to come into contact with the roller 101 disposed on the moving path of the hose 14. This roller 101 then comes into contact with the hose 14 and rotates in the direction of urging the movement of the hose 14. The roller 101 is thereby enabled to guide the hose 14 to the drum 15.

[0088] Therefore, compared with a case in which the hose 14 to be wound up by the drum 15 is not guided, disorderly winding of the hose 14 can be better prevented and the hose 14 can be wound more neatly. Also, the appearance of the wound state of the hose can be improved, and deviation of the center of gravity due to disorderly winding can be prevented.

[0089] In this configuration, the roller 101 rotates in the direction of urging the movement of the hose 14. The resistance of the hose 14 to frictional contact with the roller 101 can be thereby restrained, and the winding of the hose 14 can be facilitated.

[0090] Incidentally, though this embodiment has been described with reference to a case in which the roller 101 is disposed on the lower opening edge of the inlet/outlet 33, the choice is not limited to this, but some other rolling members such as another type of roller could give the same effect as described above.

(Third Embodiment)

[0091] A third embodiment of the invention will be described below with reference to drawings. FIG. 11 is a drawing showing a hose reel 201 in this embodiment, and the hose reel 201 is used for winding up a hose 202 for sprinkling use.

[0092] The frame 212 of this hose reel 201 is provided with disk-shaped sides 213 and legs 214 and 214 disposed between the two sides 213. Between the two sides 213, a drum 215 for winding up the hose 202 is

rotatably supported. The base ends of a handle 216 formed by bending a pipe in an angular C shape is fixed to the two sides 213, and the hose reel 201 is so configured that it can be carried by this handle 216.

[0093] The ends of a guide bar 221 as the guide part for the hose 202 to be wound up by the drum 215 is fixed to the two sides 213, and the guide bar 221 is formed by bending a pipe in a U shape. This guide bar 221 and the handle 216 are linked by a linking bar 222 to maintain the angle of inclination of the guide bar 221 relative to the handle 216.

[0094] The tip of this guide bar 221 is disposed on the moving path of the hose 202 to be wound up by the drum 215, extends in a direction crossing the moving direction of the hose 202 to be wound up, and constitutes a restrictive part 231 to prevent the hose 202 from escaping. And this restrictive part 231 is formed in an arc shape whose central part protrudes.

[0095] The drum 215 is configured of a cylindrical barrel 241 around which the hose 202 is wound and collars 242 disposed at the two ends of the barrel 241, and its ends are rotatably supported in a state of being held between the two sides 213 of the frame 212.

[0096] On the other hand, the hose 202 is configured of an inner annular member 251 disposed inside and an outer annular member 252 disposed outside the inner annular member 251 as shown in FIG. 12, and a braid 255 consisting of a net portion 253 knit of threads crossing each other diagonally and warps 254, ... extending in the lengthwise direction are disposed on the outer circumferential face of the inner annular member 251. The net portion 253 is configured of first bias threads 256, ... and second bias threads 257, ... crossing each other.

[0097] On the outer circumferential face 261 of the outer annular member 252, convex stripes 262, ... and concave grooves 263, ..., both extending in the lengthwise direction, are alternately formed to constitute striped convexes and concaves extending in the lengthwise direction.

[0098] Incidentally, the method of forming convexes and concaves in the outer circumferential face 261 is not limited to this, but the configuration may as well consist of point-shaped convexes for instance.

[0099] Further, this hose 202 is supposed to be used in all the modes for implementation including the foregoing and those to be described afterwards.

[0100] In this embodiment pertaining to the above-described configuration, when the hose 202 is wound up by turning the drum 215 with the handle 47, the hose 202 may sometimes concentrate on one end of the drum 215, i.e. on the side of one of the collars 242. However, the guide bar 221 for guiding the hose 202 is disposed on the moving path of the hose 202, and the central part of the restrictive part 231 disposed on the guide bar 221 has an arch-shaped protruding upward.

[0101] For this reason, when the hose 202 wound concentrating around an end of the drum 215 reaches a prescribed height, the hose 202 can be guided along

the restrictive part 231 in the arch-shaped toward the center.

[0102] Therefore, disorderly winding of the hose 202 concentrating on one end of the drum 215 can be prevented, and the hose 202 can be wound up neatly. Also, the appearance of the wound state of the hose can be improved, and deviation of the center of gravity can be prevented.

[0103] And when the hose is wound, the outer circumferential face 261 comes into contact with the inner face of the drum 215 or that of the frame 212 and may give rise to friction. However, as the outer circumferential face 261 of this hose 202 is made rugged in a striped shape by the convex stripes 262, ... and the concave grooves 263, ... both extending in the lengthwise direction, the frictional resistance to the area of sliding contact can be reduced.

[0104] Disorderly winding of the hose 202 around the drum 215 can be thereby better prevented than in a case in which high frictional resistance occurs to the area of sliding contact with the hose 202.

[0105] Also, the hose 202 can be smoothly wound round the drum 215, the operational power required for turning the drum 215 can be reduced, and at the same time the winding work can be facilitated.

[0106] Incidentally, though this embodiment has been described with reference to a case in which the guide bar 221 bridging the sides 213 of the frame 212 is configured of a pipe formed in a U shape, the configuration is not limited to this, but the guide part for guiding the hose 202 to be wound up by the drum 215 may instead be formed of, for instance, a wire rod, wire, pipe or plastic.

[0107] Further, though this embodiment has been described with reference to a case in which the guide bar 221 and the handle 216 are linked by the linking bar 222, the configuration is not limited to this, but the linking bar 222 can be dispensed with.

(Fourth Embodiment)

[0108] FIG. 13 shows a fourth embodiment, wherein parts having exact or equivalent counterparts in the third embodiment are denoted by respectively the same signs, their description being dispensed with.

[0109] Thus, this hose reel 301 also is of a type in which the drum 215 is exposed, and the frame 212 of the hose reel 301 is formed by bending a single pipe member. A C-shaped leg 214 is formed in the lower part of the frame 212, and erect portions 302 and 302 stand at the two ends of the leg 214. Turned-up portions 303 and 303, turned upward over the leg 214, are formed continuing from the erect portions 302 and 302, and supporting portions 304 and 304 rotatably supporting the drum 215 are disposed in the middle parts of the turned-up portions 303 and 303.

[0110] The tips of the two turned-up portions 303 and 303 are linked to the guide part 311, and the restrictive

part 231 disposed on the moving path of the hose to be wound up by the drum 215 and extending in a direction crossing the moving direction of the hose to be wound up to prevent the hose from escaping is set on the guide part 311. And this restrictive part 231 is formed in an arc shape whose central part protrudes.

[0111] This embodiment can give the same effect as the third embodiment.

[0112] In addition, since the frame 212 can be configured of a single pipe member, the configuration can be simplified and the cost reduced.

[0113] Incidentally, though the third and fourth modes for implementation has been described with reference to cases in which the restrictive part 231 is formed in a U shape, the configuration is not limited to this.

(Fifth Embodiment)

[0114] Thus, as shown in FIG. 14A, this configuration may be formed of vertical portions 401 and 401 linearly extending upward from the tips of the two turned-up portions 303 and 303, linear inclined portions 402 and 402 extending inward with an inclination from the tips of the vertical portions 401 and 401, and a linear linking portion 403 linking the two inclined portions 402 and 402.

(Sixth Embodiment)

[0115] Also, as shown in FIG. 14B, the base ends of the two vertical portions 401 and 401 may be linked by a linear lateral portion 411 to constitute a lower restrictive part.

(Seventh Embodiment)

[0116] Further, as shown in FIG. 14C, with the vertical portions 401 and 401 being abolished, the inclined portions 402 and 402 may be directly linked to the turned-up portions 303 and 303 to configure a trapezoidal restrictive part 231.

(Eighth Embodiment)

[0117] FIG. 15 shows an eighth embodiment, wherein parts having exact or equivalent counterparts in the first embodiment described above are denoted by respectively the same signs, their description being dispensed with.

[0118] Thus, on the moving path of the hose 14 to be wound up by the drum 15, which is the front face 31 of the upper vessel 13 constituting part of the body case 11, the guide part 32 for guiding the hose 14 is set. The guide part 32 is provided with the inlet/outlet 33 as the opening through which the hose 14 is to be inserted, and the upper opening edge of the inlet/outlet 33 constitutes the upper restrictive part 34 which obstructs upward escaping of the hose 14. The upper restrictive part 34 extends in a direction crossing the moving direction

l of the hose 14 to be wound up (see FIG. 1), and the upper restrictive part 34 is formed in an angle or trapezoidal shape whose central part protrudes upward.

[0119] This upper restrictive part 34 is linked to the two ends of the lower restrictive part 36 which the lower edge of the inlet/outlet 33 constitutes, and is configured of inclined parts 501 and 501 inclined toward the central part of the inlet/outlet 33 as they extend upward and a horizontal portion 502 linking the upper ends of the two inclined parts 501; the inclination angle β between the horizontally extending lower restrictive part 36 and the inclined parts 501 and 501 is set in a range of not less than 45 degrees and less than 90 degrees.

[0120] When the hose 14 is wound by turning the drum 15 in the configuration described above, the hose 14 may sometimes concentrate on one end of the drum 15. However, the guide part 32 for guiding the hose 14 is provided on the moving path of the hose 14, and the inclined parts 501 and 501 inclined toward the central part as they extend upward are set on the upper restrictive part 34 set on the guide part 32.

[0121] As a result, the hose 14 wound concentrating on the end of the drum 15 can be guided toward the center of the inlet/outlet 33 by the inclined parts 501 and 501 when a prescribed quantity has been wound up.

[0122] Therefore, disorderly winding of the hose 14 concentrating on one end of the drum 15 can be prevented, and the hose 14 can be wound up neatly. Also, the appearance of the wound state of the hose can be improved, and deviation of the center of gravity due to disorderly winding can be prevented.

[0123] Although a vertical component of force F1 and a horizontal component of force F2 then work on the hose 14 in contact with these inclined parts 501 and 501, but the inclination angle β of the inclined parts 501 is set to be not less than 45 degrees and less than 90 degrees. As a result, the horizontal component of force F2 is not less than the vertical component of force F1, and the force of guiding the hose 14 wound up in the prescribed quantity toward the central part can be kept not less than the force pressing the hose 14 downward.

[0124] For this reason, it is possible to prevent the hose 14 wound up in the prescribed quantity from being squeezed in a state of being pressed down from above.

(Ninth Embodiment)

[0125] FIG. 16 shows a hose reel 601 in the ninth embodiment; the hose reel 601 is used for winding up a hose for sprinkling use.

[0126] This hose reel 601 is provided with a rectangular body case 611 constituting a frame, and the width C1 of the body case 611 is set to 220 mm. The length C2 of the body case 611 is set to 375 mm and its height C3, to 394.8 mm.

[0127] This body case 611, as shown in FIG. 17, is formed by a lower vessel 612 as the upward open lower constituent member of an rectangular container and an

upper vessel 613, which is the downward open upper constituent member of the rectangular container, coupled with tapping screws not shown. The internal space K of this body case 611 accommodates a drum 615 around which a hose 614 of 16.4 mm in diameter HD is to be wound as shown in FIG. 18.

[0128] The hose 614 is set to be 2.2 mm in thickness HT and to 12 mm in inner diameter HI. Further, a plurality of convex stripes 620, ... extending in the lengthwise direction are formed over the whole length of the outer circumferential face.

[0129] The drum 615 is configured of a cylindrical barrel 617 around which the hose 614 having penetrated a hose insertion hole 616 is wound and collars 618 and 618 disposed at the two ends of the barrel 617, and the winding position 619 of the hose 614 is set between the two collars 618 and 618.

[0130] This drum 615 is set to a capacity sufficient for winding the hose 614 of 25 m. The length of the hose 614 to be wound up by this drum 615 is set to 80% of it, i.e. 20 m. It is thus designed to be able to wind up the hose 614 at a lower material cost than where a drum of a larger diameter is used. Further by keeping the height C3 lower, the body case 611 which would not easily fall down is realized.

[0131] To add, it is desirable for the length of the hose 614 to be wound around the drum 615 to be not greater than 80% of what the drum 615 can accommodate.

[0132] More specifically, the diameter DD of the collars 618 and 618 is set to 280 mm and the distance H2 between the two collars 618 and 618, to 144 mm (see FIG. 22). Thus, the distance H2 between the two collars 618 and 618 is set to be 40% to 60% of the diameter DD of the collars 618 and 618, i.e. between 112 mm and 168 mm.

[0133] While the winding ease of the hose 614 can be enhanced by reducing the distance H2 between the collars 618 and 618 of the drum 615 herein, too short a distance H2 between the collars 618 and 618 would make the drum 615 thin and apt to easily fall down. In view of this factor, repeated experiments have led to a discovery that the two requirements can be made consistent with each other by setting the distance H2 between the collars 618 and 618 of the drum 615 to between 40% and 60% of the diameter DD of the collars 618 and 618. For this reason, in this embodiment, the distance H2 between the collars 618 and 618 of the drum 615 is set to 144 mm, which lies between 40% and 60% of the diameter DD of the collars 618 and 618.

[0134] Incidentally as another variation, there is made available a configuration in which the distance H2 between the collars 618 and 618 of this drum 615 is set to 171 mm and the diameter DD of the collars 618 and 618, to 340 mm, i.e. the distance H2 between the collars 618 and 618 is set between 40% and 60% of the diameter DD of the collars 618 and 618. In this drum 615, the accommodable length of the hose 614 is 38 m, and the length of the hose 614 to be wound around the drum

615 is set to be 30 m, not more than 80% of that accommodable length.

[0135] The top plate 621 of the upper vessel 613 is formed rectangular and flat as shown in FIG. 16 and FIG. 20. The top plate 621, set to be large enough to permit the mounting of the body case 611 of another hose reel, constitutes a load carrier.

[0136] A C-shaped concave 622 is formed in this top plate 621, and a C-shaped handle 623 is arranged in the concave 622. The handle 623 is composed of a grip 624 constituting a free end and extension parts 625 and 625 extending from the two ends of the grip 264 into the C shape, and turnably supported by the upper vessel 613 via rotation shafts 626 and 626 disposed at the tips of the extension parts 625 and 625 as shown in FIG. 21. In this way, the handle 623 is so configured as to be turnable between an inclined state 627 in which it is accommodated in the concave 622 and an erect state 628 in which it is erect.

[0137] These extension parts 625 and 625 of the handle 623 are so configured that its turning is restricted as it comes into contact, in its erect state 628, with a contact part 629 consisting of the upper edge of the concave 622, and the contact part 629 is composed of an inclined face which is inclined forward. The handle 623 is so configured that, in this erect state 628, its turning is restricted at a prescribed angle 6α beyond 90 degrees, more specifically 109 degrees from the inclined state 627. By virtue of this arrangement, when the handle 623 in the inclined state 627 is to be shifted to the erect state 628, after the grip 624 constituting the free end of the handle 623 passes above the center of turning consisting of the rotation shafts 626, the extension parts 625 and 625 stop in a forward inclined state in contact with the contact part 629.

[0138] On the moving path of the hose 614 wound up by the drum 615, the path being the front face 631 of the upper vessel 613, a guide part 632 for guiding the hose 614 is disposed as shown in FIG. 22. The guide part 632 is provided with an inlet/outlet 633 as an opening through which the hose 614 is inserted, and the inlet/outlet 633 is disposed in the position opposite the winding position 619 set between the two collars 618 and 618 of the drum 615.

[0139] The width H1 of the inlet/outlet 633 is set to be not greater than the distance H2 from one of the collars 618 of the drum 615 to the other collar 618. More specifically, the width H1 at the lower end of the inlet/outlet 633, its greatest width, is set between 134 mm and 154 mm, preferably should be set not greater than 144 mm, the distance H2 between the two collars 618 and 618 of the drum 615, and in this embodiment it is set to be less than 144 mm. The height H3 of the inlet/outlet 633 in the central part, its greatest height is set to be 100 mm.

[0140] Incidentally, though the width H1 of the inlet/outlet 633 is set to be less than the distance H2 between the two collars 618 and 618 of the drum 615 in this embodiment, the two dimensions may as well be the same.

[0141] To add, the relationship between the width H1 of the inlet/outlet 633 and the distance H2 between the two collars 618 and 618 is not limited to this, but the width H1 may as well be not greater than the distance H2, preferably not less than 2/3 of the distance H2.

[0142] The upper opening edge of this inlet/outlet 633 constitutes an upper restrictive part 634 for obstructing the hose 614 from escaping upward. The upper restrictive part 634 extends in a direction crossing the moving direction 61 of the hose 614 that is wound up (see FIG. 1), and the upper restrictive part 634 is formed in an arc shape whose central part protrudes upward.

[0143] The starting point S of the arc shape of the opening edge of the inlet/outlet 633 is set in the position of the height of the lower edge of the inlet/outlet 633 and between the center of rotation DC of the drum 615 and the highest position DS of the collars 618 and 618. As a result, the width H1 of the inlet/outlet 633 decreases from the lower edge upward.

[0144] Incidentally, though the foregoing description referred to a case in which the upper restrictive part 634 is formed by the upper opening edge of the inlet/outlet 633, but the configuration is not limited to this, but it may as well consist of a long member curved in an arc shape for instance.

[0145] Also the lower opening edge of the inlet/outlet 633 may be open.

[0146] A lean-to cover 635 is formed over the whole area of this upper restrictive part 634 as shown in FIG. 21, and the lean-to cover 635 protrudes toward outside the body case 611. The height of the upper restrictive part 634 in its highest position is set to be lower than the highest positions of the collars 618 of the drum 615 supported by the body case 611, and an allowance 6Y for winding up the hose is provided between the highest position of the upper restrictive part 634 and the highest positions of the collars 618.

[0147] The lower opening edge of the inlet/outlet 633 is linearly formed as shown in FIG. 22, and a lower restrictive part 636 to allow the hose 614 to move in the horizontal direction is formed on the moving path of the hose 614. This causes the inlet/outlet 633 to be formed in a semicircular shape whose arch-shaped part is positioned at the top.

[0148] The lower restrictive part 636 constituting the opening edge of the inlet/outlet 633 is formed thicker than the general part 637 and constitutes a thick part 638 as shown in FIG. 21. The sectional shape of this thick part 638 is formed in an arc shape protruding toward the center of the inlet/outlet 633, and the configuration is such that the hose 614 moving through the inlet/outlet 633 comes into line contact.

[0149] At the joints between the lower ends of the left and right sides 641 and 642 of this upper vessel 613 and the upper ends of the left and right sides 643 and 644 of the lower vessel 612, there are formed bulgy parts 645 and 645 bulging sideways, which constitute a circular form when joined together, as shown in FIG. 16

and FIG. 22, and end parts of the barrel 617, protruding from the collars 618 and 618 of the drum 615, are rotatably supported between the bulgy parts 645 and 645 as shown in FIG. 18. Round holes 646 and 646 are provided at the centers of these bulgy parts 645 and 645, and the shaft 648 of a crank-shaped handle 647 for turning the drum 615 is inserted into the round hole 646 of the bulgy part 645 arranged on the left side.

[0150] Also, a connecting plug 651 for connecting the faucet side hose is inserted into the round hole 646 of the bulgy part 645 arranged on the right side, and one end of a pipe member 652 to be connected to the hose 614 wound around the drum 615 is connected to the connecting plug 651. This configuration enables running water from the faucet to the pipe member 652 via the connecting plug 651 and to the hose 614 on the sprinkling side, wound around the drum 615, via the pipe member 652.

[0151] On the left and right sides 641, 642, 643 and 644 of the upper and lower vessels 612 and 613 on which the bulgy parts 645 and 645 are formed, hoop-like parts 655 and 655 extending upward and downward are disposed in the upper and lower positions of the bulgy parts 645 and 645, which are the positions of supporting the drum 615, as shown in FIG. 16. These hoop-like parts 655 and 655 are formed in a corrugated shape by alternately arranged a plurality of convex stripes 656, ... and concave grooves 657, ..., both extending upward and downward. These hoop-like parts 655 and 655 are thereby configured to reinforce the planar left and right sides 641, 642, 643 and 644 and to function as props to support the drum 615.

[0152] A rectangular bottom opening 662 is cut in the bottom 661 of the lower vessel 612 as shown in FIG. 23, and the body case 611 communicates with outside via this bottom opening 662.

[0153] Laterally long leg-fixing members 665 and 665 are screwed on along the edges of the front face side 631 and the rear face side 668 of the bottom 661. Cross-shaped shafts 666 and 666 protrude in mutually opposite directions at the two ends of the leg fixing members 665 and 665 as shown in FIG. 24, and legs 667 and 667 formed in the same shape are rotatably supported by the opposite shafts 666 and 666.

[0154] At both ends of these legs 667, cylindrical parts 671 and 671 to externally fit onto the shafts 666 and 666 to constitute base ends 672, and top plate parts 673 extending toward the tips are integrally formed with these cylindrical parts 671. The legs 667 and 667 are so configured as to be able to form as desired by turning around the cylindrical parts 671 and 671 a folded state 674 in which, as shown in FIG. 25, the tips of both legs 667 and 667 are arranged underneath the body case 611 and both legs 667 and 667 are arranged underneath the bottom opening 662 or a developed state 675 in which, as shown in FIG. 16, the tips of both legs 667 and 667 extend sideways from the body case 611 and are in contact with the bottom 661 of the body case 611

(see FIG. 24) to be restricted in turning.

[0155] The configuration is such that the erect state of the body case 611 can be thereby stabilized in the developed state 675 and, in the folded state 674, the bottom opening 662 cut in the bottom 661 can be closed by the legs 667 and 667.

[0156] The top plate parts 673 are formed in such lengths that, when one leg 667 is folded ahead of the other leg 667 to constitute the folded state 674 shown in FIG. 26, the parts of the two legs 667 and 667 farther out than the base ends 672 and 672 overlap each other on their tip side, and on their rear faces a plurality of the ribs 681, ... and flanges 682 and 682 extending from their two side edges are integrally formed. The heights of these flanges 682 and 682 and the ribs 681, ... are set to become lower from the base ends 672 toward the tips as shown in FIG. 24, and the thickness of each leg 667 is set to become thinner from the base ends 672 pivoting on the body case 611 toward the tip.

[0157] Further, the thickness of the legs 667 and 667 in their overlapping parts 683, as shown in FIG. 25, is so set that the sum of their thickness counts overlapping each other in the folded state 674 be not greater than the greatest thickness of the legs 667 and 667, i.e. at the base ends 672, resulting in a configuration in which the legs 667 and 667 are positioned above the under faces of the leg fixing members 665 in the folded state 674.

[0158] And as shown in FIG. 21, two ribs 692 and 692 extend from the bottom 661 toward the upper opening on an inner side face 691 of the lower vessel 612 of the body case 611, and two ribs 694 and 694 also extend from the top plate 621 toward the lower opening on an inner side face 693 of the upper vessel 613 of the body case 611. Thus, these ribs 692, 692, 694 and 694 extend in the direction of mold drawing when the vessels 612 and 613 are molded of resin.

[0159] The height 6H of the ribs 692, 962, 694 and 694, as shown in FIG. 18, is set to be not less than the separation distance 6R from each of the inner side faces 691 and 693 to the collars 618 of the drum 615, the lengths of the ribs 692, 692, 694 and 694, as shown in FIG. 21, are so set as to bring their tips close to the collars 618.

[0160] In this embodiment pertaining to the configuration described above, the body case 611 as a frame for rotatably supporting the drum 615 of the hose reel 601 is formed in a case shape allowing accommodation of the drum 615, the inlet/outlet 633 for the hose 614 is disposed in the position in the body case 611 opposite the winding position 619 between the two collars 618 and 618 of the drum 615, and the hose 614 wound up by the drum 615 moves via this inlet/outlet 633.

[0161] And the width H1 of this inlet/outlet 633 is set to be not greater than the distance H2 from one collar 618 of the drum 615 to the other collar 618. As a result, the hose 614 accommodated into the body case 611 via the inlet/outlet 633 can be guided to the position be-

tween the two collars 618 and 618 of the drum 615.

[0162] Therefore, compared with the conventional case in which the winding direction of the hose 614 is open and the hose 614 is apt to be wound into the gap between the drum 615 and the frame, the winding of the hose 614 into the gap between the drum 615 and the inner face of the body case 611 can be prevented, and the hose 614 can be wound up neatly.

[0163] Especially, where the body case 611 is formed in a case shape and the hose 614, if wound into the gap between the drum 615 and the body case 611, will be difficult to take out as in this embodiment, any problem due to the winding-in can be prevented from arising.

[0164] Further, the distance H2 between the two collars 618 and 618 provided at the two ends of the barrel 617 of the drum 615 around which the hose 614 is to be wound is set between 40% and 60% of the diameter DD of the collars 618 and 618; when the hose 614 is wound around such a drum 615, even if the hose 614 is wound concentrating on one of the collars 618, a collapse will arise within. For this reason, the hose 614 is guided to a position between the two collars 618 and 618 by being wound around this drum 615. This can prevent the hose 614 from inadvertently coming off the drum 615.

[0165] Therefore, compared with the conventional case in which the hose is apt to be wound into the gap between the drum and the frame, the winding of the hose 614 into the gap between the drum 615 and the inner face of the body case 611 can be prevented, and the hose 614 can be wound up neatly. Further, as the hose 614 wound concentrating on one of the collars 618 can be collapsed inward, it can be stabilized at the time of winding.

[0166] And the setting of the distance H2 between the collars 618 and 618 of the drum 615 between 40% and 60% of the diameter DD of the collars 618 and 618 facilitates winding of the hose 614 and can make the hose reel 601 difficult to fall down.

[0167] And when the hose 614 is wound up by the drum 615, the hose 614 may sometimes concentrate on the collar 618 at one end of the drum 615. However, the upper opening edge of the inlet/outlet 633 through which the hose 614 moves is set to have a width H which becomes narrower upward, and is formed in an arc shape whose central part protrudes upward.

[0168] For this reason, the hose 614 wound concentrating on one end of the drum 615, when wound up to a prescribed quantity, is guided toward the center along the arch-shaped opening edge.

[0169] Thus, even when the hose 614 is concentrating on the collar 618 at one end of the drum 615, the hose can be guided toward the center along the arch-shaped opening edge at the time it has been wound up to the prescribed quantity. This can prevent disorderly winding, i.e. winding of the hose 614 concentrating on one end of the drum 615, and the wound state of the hose 614 can be evened up. Therefore, deviation of the center of gravity due to disorderly winding can be pre-

vented.

[0170] Furthermore, the starting point S of the arc shape of the opening edge of the inlet/outlet 633 is set between the center of rotation DC of the drum 615 and the highest position DS of the collars 618 and 618. As a result, the hose 614 wound concentrating on the collar 618 at one end of the drum 615 can be guided toward the center along the arch-shaped opening edge before it reaches the highest position DS of the collars 618 and 618.

[0171] Incidentally, though the foregoing description referred to a case in which the starting point S of the arc shape of the opening edge is set on the lower edge of the inlet/outlet 633, but the configuration is not limited to this, but a linear portion 6101 rising from the lower edge of the inlet/outlet 633 may be disposed and an arch portion 6102 in an arch shape formed from its upper end as shown in FIG. 26.

[0172] In this case, the starting point S on the border between the linear portion 6101 and the arch portion 6102 is set between the center of rotation DC of the drum 615 and the highest position DS of the collars 618 and 618.

[0173] Nor is the inlet/outlet 633 limited to the above-described shape, but may as well be semicircular as shown in FIG. 27A or triangular as in FIG. 27B.

[0174] Further, where the inlet/outlet 633 is to be triangularly shaped, its two upper sides 6111 and 6111 may be rounded, bent toward the center of the opening, as shown in FIG. 28A, and the range of rounding could be set between 100R and 300R for example.

[0175] In addition, where the inlet/outlet 633 is to be triangularly shaped, its two upper sides 6121, 6121 may be rounded, bent outward from the center of the opening, as shown in FIG. 28B, and the range of rounding could be set between 100R and 300R for example.

Industrial Applicability

[0176] As hitherto described, the hose reel according to Claim 1 of the present invention, even when the hose is wound concentrating on one end of the drum, it can be guided along the guide part, whose width decreases toward its upper portion, toward the central part when a prescribed quantity has been wound up.

[0177] Therefore, disorderly winding of the hose concentrating on one end of the drum can be prevented, and the hose can be wound neatly. Also, the appearance of the wound state of the hose can be improved and deviation of the center of gravity due to disorderly winding can be prevented.

[0178] Also the hose reel according to Claim 2 of the invention, even when the hose is wound concentrating on one end of the drum, it can be guided by an inclined part provided in the restrictive part toward the central part when a prescribed quantity has been wound up.

[0179] Therefore, disorderly winding of the hose concentrating on one end of the drum can be prevented,

and the hose can be wound neatly. Also, the appearance of the wound state of the hose can be improved and deviation of the center of gravity due to disorderly winding can be prevented.

[0180] Then, a downward component of force and a horizontal component of force arise in the hose that has come into contact with this inclined part, and the angle of inclination of the inclined part is set to be not less than 45 degrees and less than 90 degrees. For this reason, the horizontal component of force is not less than the downward component of force, and the force guiding the hose stacked to a prescribed quantity toward the central part is not less than the force pressing the hose downward.

[0181] Therefore, it is possible to prevent the hose wound up in the prescribed quantity from being squeezed in a state of being pressed down from above.

[0182] Further, the hose reel according to Claim 3 of the invention, even when the hose is wound concentrating on one end of the drum, it can be guided along an arch-shaped restrictive part toward the central part when a prescribed quantity has been wound up.

[0183] Therefore, disorderly winding of the hose concentrating on one end of the drum can be prevented, and the hose can be wound neatly. Also, the appearance of the wound state of the hose can be improved and deviation of the center of gravity due to disorderly winding can be prevented.

[0184] Or in the hose reel according to Claim 4 of the invention, when starting winding of the hose around an empty drum, the hose to be moved can be guided along the lower opening edge of the opening in the guide part. In this arrangement this lower opening edge is linearly formed. As a result, the hose guided by the guide part can be wound around the whole area of the drum in a distributed way, and disorderly winding at the time of starting the winding can be prevented.

[0185] And when a prescribed quantity of the hose has been wound up around the drum, it is guided along the restrictive part formed by the upper opening edge of the opening in the guide part. This provides a similar effect to what was described above.

[0186] Further in the hose reel according to Claim 5 of the invention, the drum is supported by the frame, and the guide part can be configured by providing this frame with a bar. This contributes to simplifying the configuration.

[0187] In addition, in the hose reel according to Claim 6 of the invention, by inserting the hose to be wound up by the drum into the opening of the guide part, the hose can be brought into sliding contact with the opening edge of the opening and thereby guided to its prescribed position.

[0188] Therefore, compared with a case in which the hose to be wound up by the drum is not guided, disorderly winding of the hose can be better prevented and the hose can be wound more neatly. Also, the appearance of the wound state of the hose can be improved,

and deviation of the center of gravity due to disorderly winding can be prevented.

[0189] In this configuration, the thick part thicker than the general part is set for the opening edge of the opening. For this reason, inadvertent bending of the hose can be more securely prevented than in a case in which the opening edge is composed of a thin part, resulting in improved ease of winding.

[0190] Moreover, in the hose reel according to Claim 7 of the invention, by inserting the hose to be wound up by the drum into the opening of the guide part, the hose can be brought into sliding contact with the opening edge of the opening and thereby guided to its prescribed position.

[0191] Therefore, compared with a case in which the hose to be wound up by the drum is not guided, disorderly winding of the hose can be better prevented and the hose can be wound more neatly. Also, the appearance of the wound state of the hose can be improved, and deviation of the center of gravity due to disorderly winding can be prevented.

[0192] In this configuration, the opening edge of the opening is formed in a sectional shape of an arc shape protruding toward the center of the opening. As a result, the area of contact with the hose in sliding contact can be reduced, and the frictional resistance occurring at the time of winding can be restrained. Therefore, the winding of the hose can be facilitated.

[0193] Further in the hose reel according to Claim 8 of the invention, the hose to be wound up by the drum can be guided by the rotational member rotating in contact with the hose.

[0194] Therefore, compared with a case in which the hose to be wound up by the drum is not guided, disorderly winding of the hose can be better prevented and the hose can be wound more neatly. Also, the appearance of the wound state of the hose can be improved, and deviation of the center of gravity due to disorderly winding can be prevented.

[0195] In this configuration, the roller rotates in the direction of urging the movement of the hose. Accordingly, the resistance of the hose to frictional contact with the roller can be thereby restrained, and the winding of the hose can be facilitated.

[0196] And in the hose reel according to Claim 9 of the invention, the frictional resistance between the outer circumferential face and the area of sliding contact can be reduced by making the outer circumferential face of the hose rugged. Compared with a case in which a high frictional resistance occurs in the area of sliding contact with the hose, disorderly winding of the hose around the drum can be better prevented.

[0197] The winding of the hose around the drum is further smoothed, the operational power required for turning the drum can be reduced, and at the same time the winding work can be facilitated.

[0198] Moreover, in the hose reel according to Claim 10 of the invention, the width of the inlet/outlet provided

in the frame is set to be not greater than the distance from one collar of the drum to the other, and the hose accommodated into the frame via the inlet/outlet can be guided to the position between the two collars of the drum.

[0199] Therefore, compared with the conventional case in which the winding direction of the hose is open and the hose is apt to be wound into the gap between the drum and the frame, the winding of the hose into the gap between the drum and the inner face of the body case can be prevented, and the hose can be wound up neatly.

[0200] Especially, where the frame is formed in a case shape as in the hose reel according to Claim 11, if the hose is wound into the gap between the drum and the frame and is difficult to take out, any problem due to the winding-in can be prevented from arising.

[0201] Moreover, in the hose reels according to Claims 12 and 13, even if the hose is wound concentrating on one end of the drum, it can be guided along the opening edge of the inlet/outlet or the arch-shaped opening edge toward the center when a prescribed quantity has been wound up.

[0202] This can prevent disorderly winding, i. e. winding of the hose concentrating on one end of the drum, and enable the wound state of the hose to be evened up.

[0203] Therefore, deviation of the center of gravity due to disorderly winding can be prevented, and the quantity of hose set at the time of designing can be wound around the drum.

[0204] Further in the hose reel according to Claim 14, as the starting point of the arc shape of the opening edge is set between the center of rotation of the drum and the highest position of the collars, the hose concentrating on the collar at one end of the drum can be guided toward the center along the arch-shaped opening edge before it reaches the highest position of the collars.

[0205] Moreover, in the hose reel according to Claim 15, as the distance between the collars of the drum is set between 40% and 60% of the diameter of the collars, the hose wound around this drum can be guided between the collars. Therefore any trouble due to the going astray of the hose from the drum can be prevented, resulting in neat winding of the hose.

[0206] Also, as the hose wound concentrating on one of the collars can be collapsed inward, it can be stabilized at the time of winding. And the setting of the distance between the collars of the drum between 40% and 60% of the diameter of the collars facilitates winding of the hose and can make the hose reel difficult to fall down.

Claims

1. A hose reel for winding a hose by turning a drum, **characterized in that** a guide part for guiding the hose is provided on the moving path of the hose to

be wound around said drum and the width of the guide part is so set as to decrease toward its upper portion.

5 2. A hose reel for winding a hose by turning a drum, **characterized in that** a guide part for guiding the hose is provided on the moving path of the hose to be wound around said drum, a restrictive part for preventing said hose from escaping is extended on the guide part in a direction crossing the moving direction of said hose, an inclined part inclined toward the central part is set on said restrictive part, and the angle of inclination in the inclined part is set to be not less than 45 degrees and less than 90 degrees.

10 3. A hose reel for winding a hose by turning a drum, **characterized in that** a guide part for guiding the hose is provided on the moving path of the hose to be wound around said drum, a restrictive part for preventing said hose from escaping is extended on the guide part in a direction crossing the moving direction of said hose, and said restrictive part is formed in an arc shape whose central part protrudes.

15 4. The hose reel according to Claim 3, **characterized in that** an opening through which said hose is inserted is provided in said guide part, said restrictive part is set in the upper opening edge of the opening, and the lower opening edge of said opening is linearly formed.

20 5. The hose reel according to Claim 3, **characterized in that** said drum is supported by a frame, and said guide part is composed of a bar disposed on said frame.

25 6. A hose reel for winding a hose by turning a drum, **characterized in that** a guide part having an opening through which the hose is inserted is provided on the moving path of the hose to be wound around said drum, and a thick part thicker than a general part is disposed on the opening edge of said opening.

30 7. A hose reel for winding a hose by turning a drum, **characterized in that** a guide part having an opening through which the hose is inserted is provided on the moving path of the hose to be wound around said drum, and the sectional shape of the opening edge of said opening is formed in an arc protruding toward the center of said opening.

35 8. A hose reel for winding a hose by turning a drum, **characterized in that** a rotational member in contact with the hose and rotating in the direction of urging the movement of the hose is disposed on the

moving path of the hose to be wound up by said drum.

9. The hose reel according to any of Claims 1 through 8, **characterized in that** the outer circumferential face of said hose is made rugged. 5
10. A hose reel wherein a drum having collars at the two ends of its barrel is turnably supported by a frame, **characterized in that** said frame is formed in a shape allowing accommodation of said drum, an inlet/outlet for the hose is disposed in a position in said frame opposite the winding position between the two collars of said drum, and the width of the inlet/outlet is set to be not greater than the distance from one collar of said drum to the other. 10
15
11. The hose reel according to Claim 10, **characterized in that** said frame is formed in a case shape for accommodating said drum. 20
12. The hose reel according to Claim 10 or 11, **characterized in that** the width of said inlet/outlet is set to become smaller toward the upper part. 25
13. The hose reel according to Claim 10, 11 or 12, **characterized in that** the opening edge of said inlet/outlet on the upper side is formed in an arc shape whose central part protrudes upward. 30
14. The hose reel according to any of Claims 10 through 13, **characterized in that** the starting point of the arc shape of said opening edge is set between the center of rotation of said drum and the highest position of said collars. 35
15. A hose reel wherein a drum having collars at the two ends of its barrel is turnably supported by a frame, **characterized in that** the distance between said two collars is set between 40% and 60% of the diameter of said collars. 40
45
50
55

FIG. 1

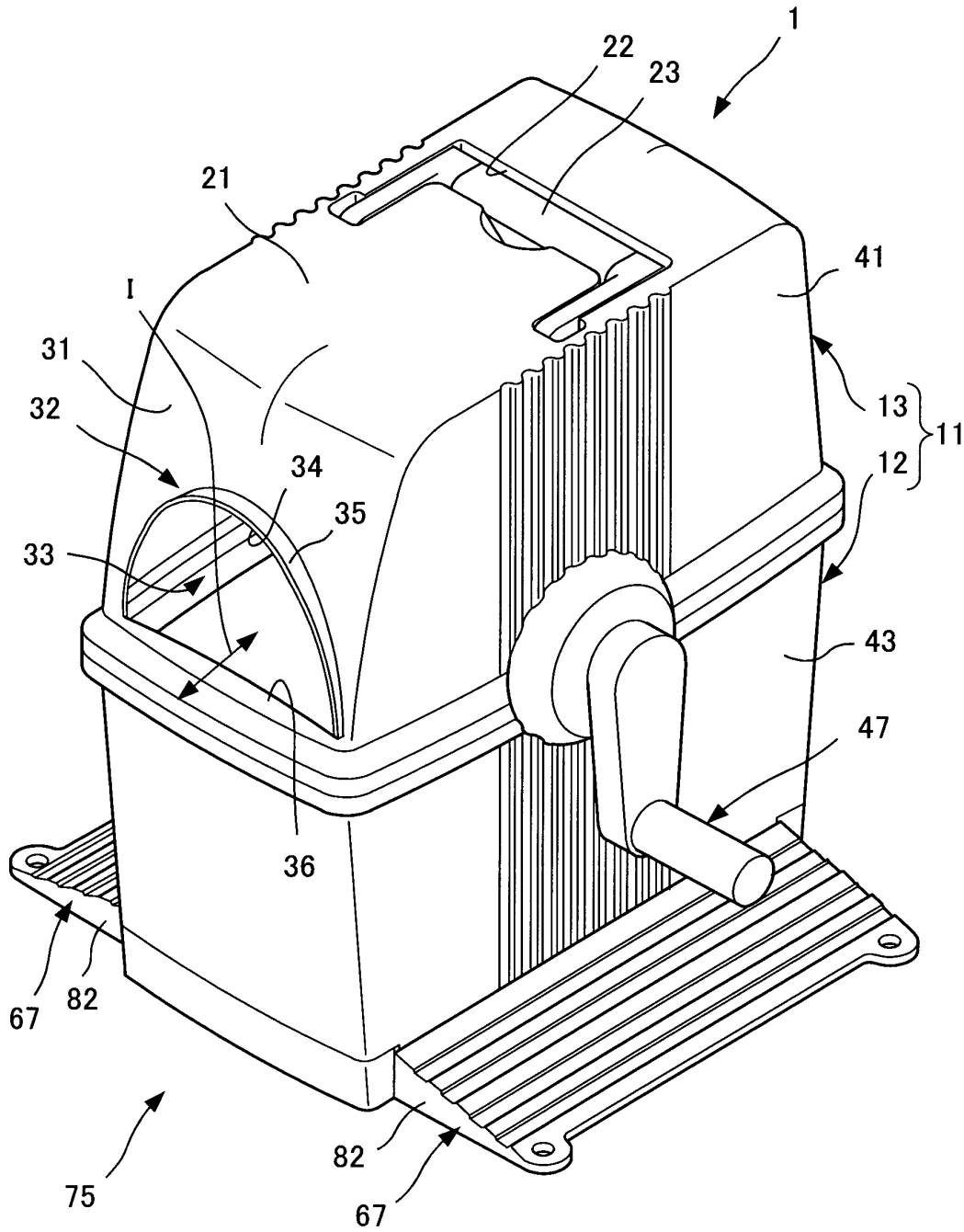

FIG.2

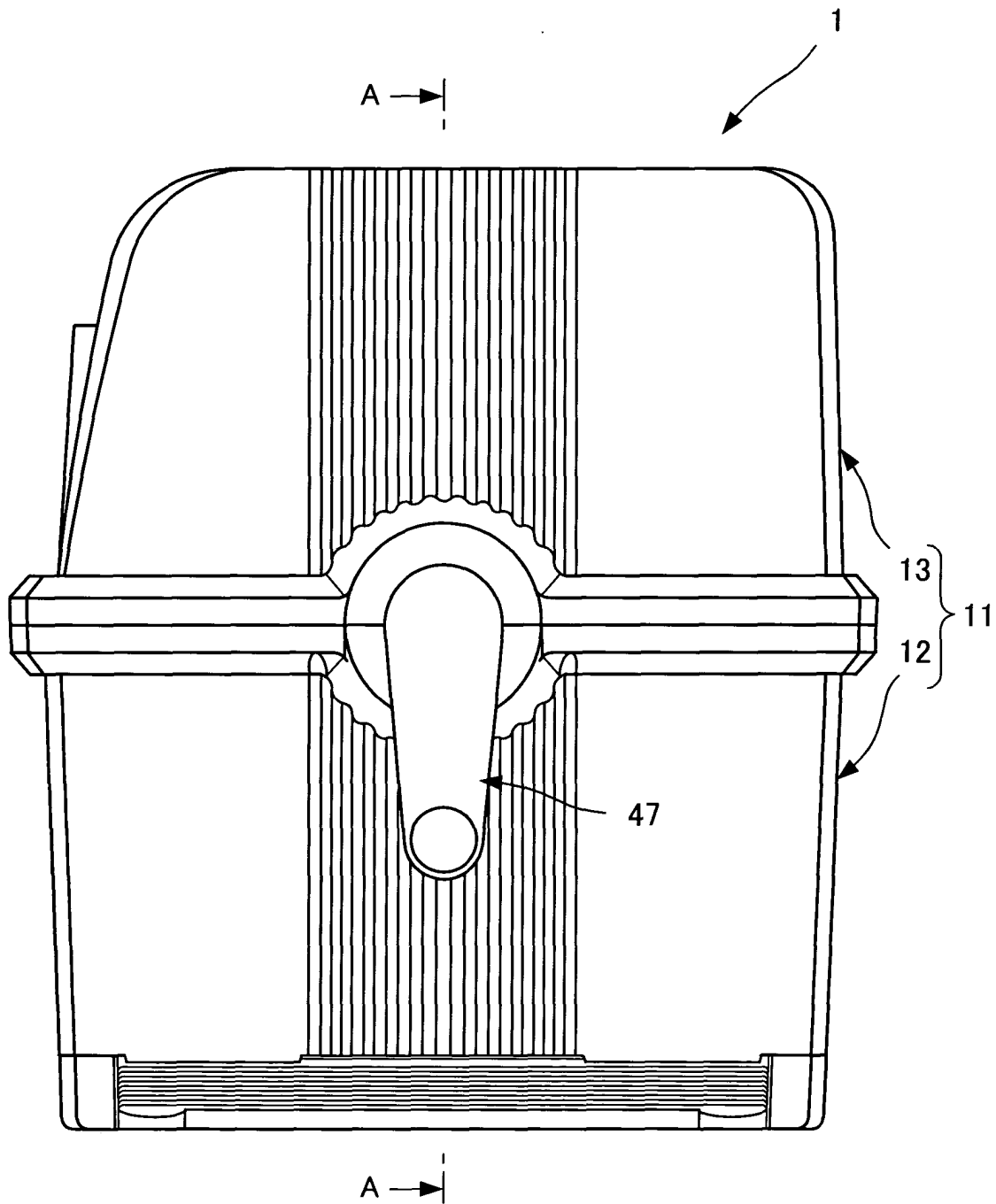

FIG.3

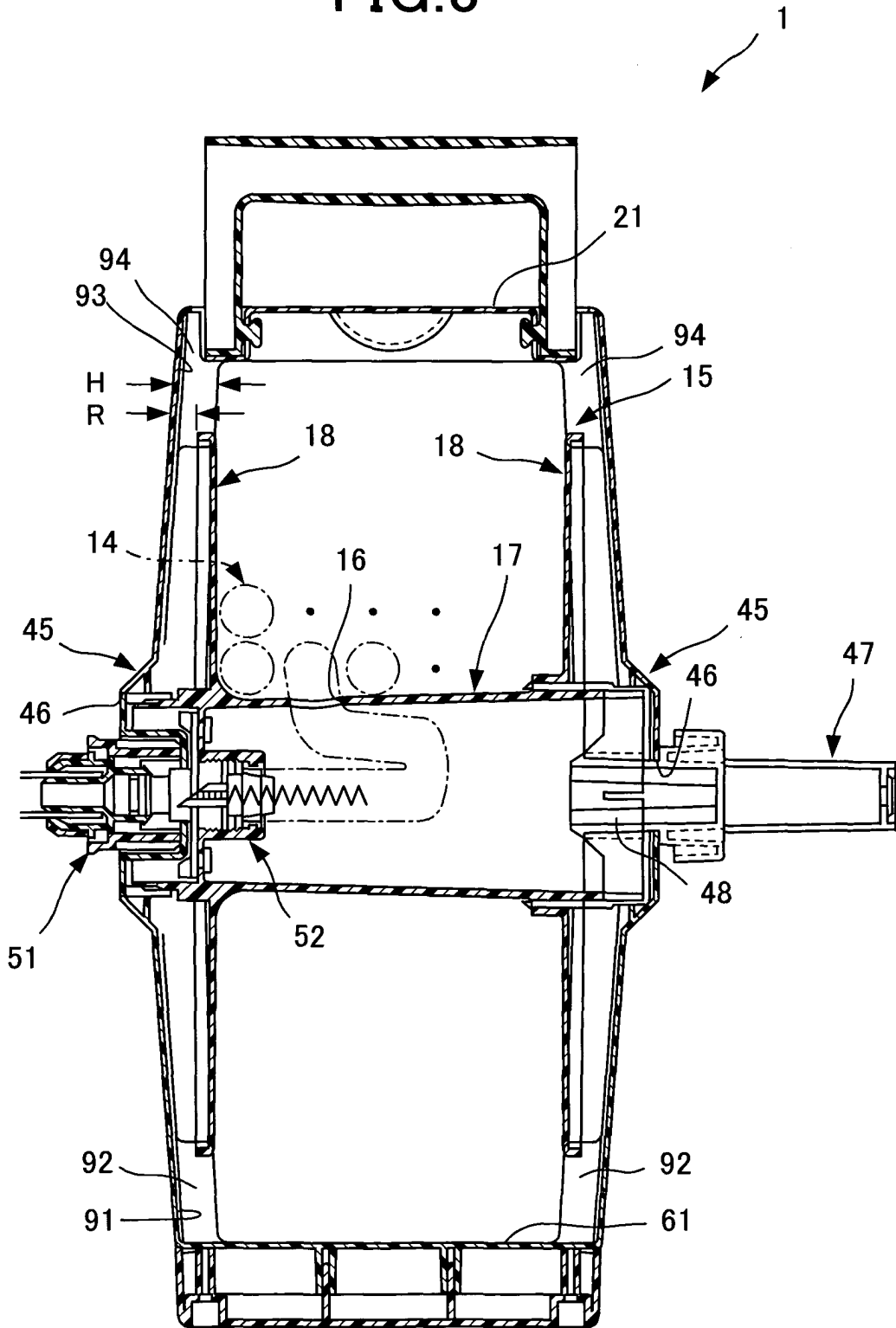

FIG.4

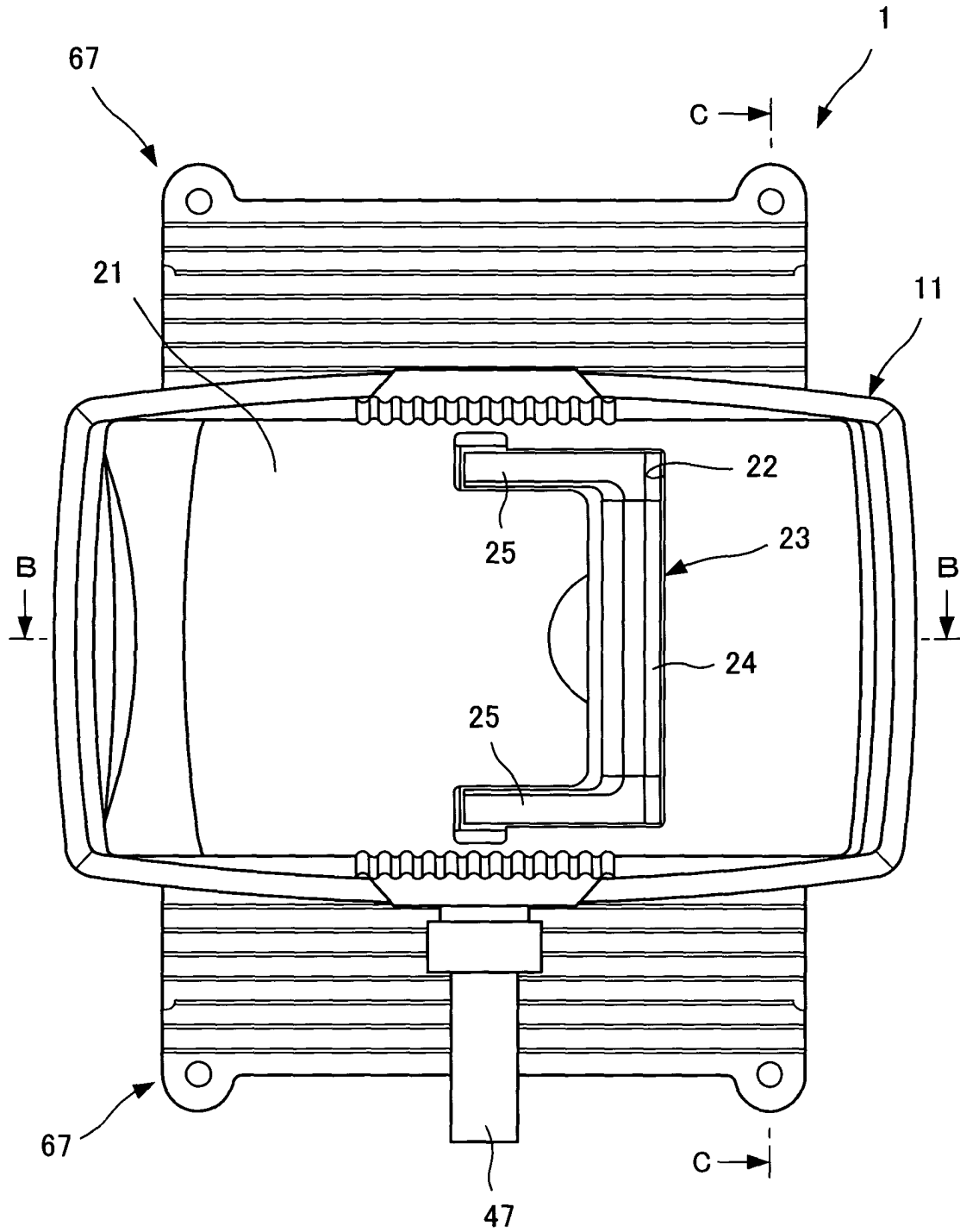

FIG.5

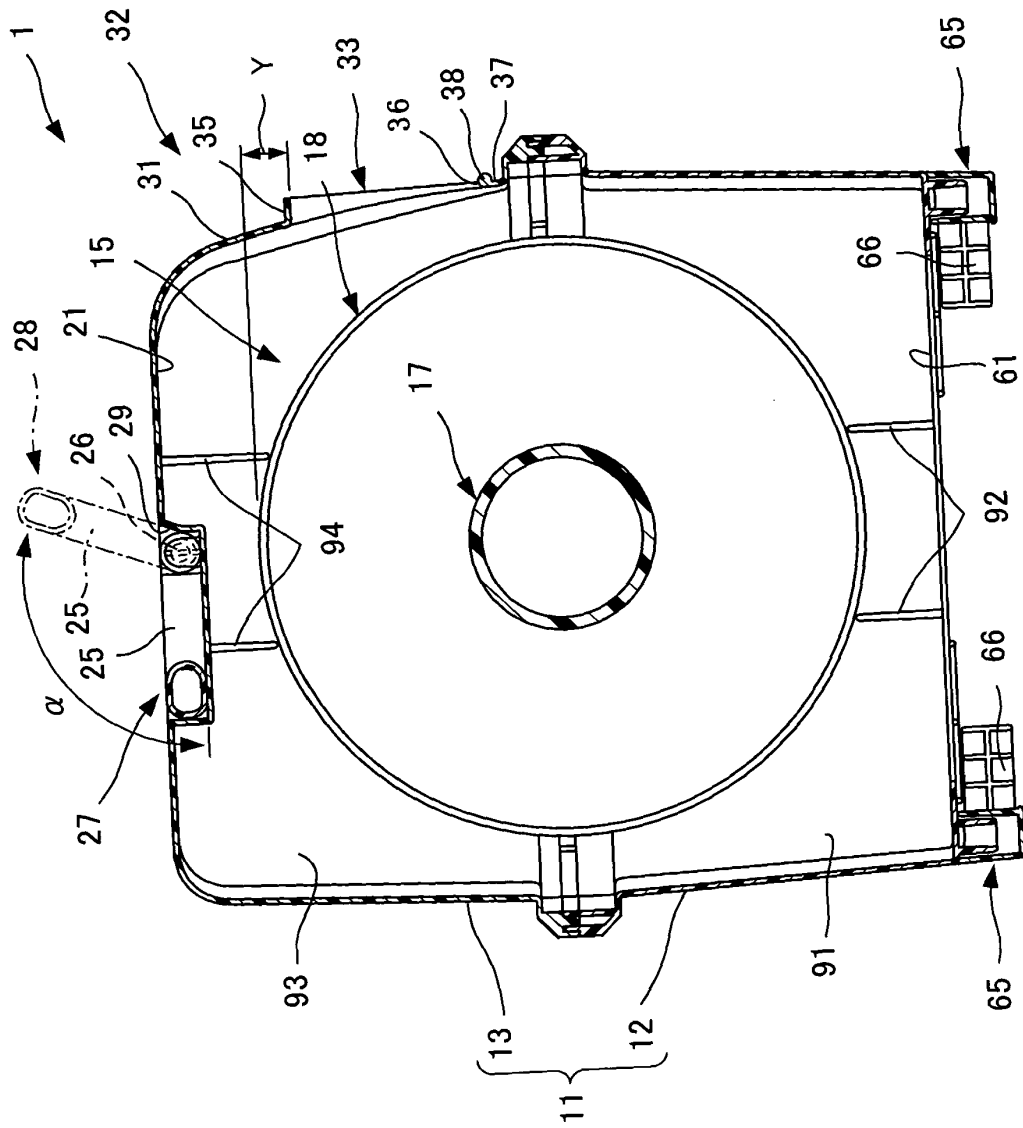

FIG.6

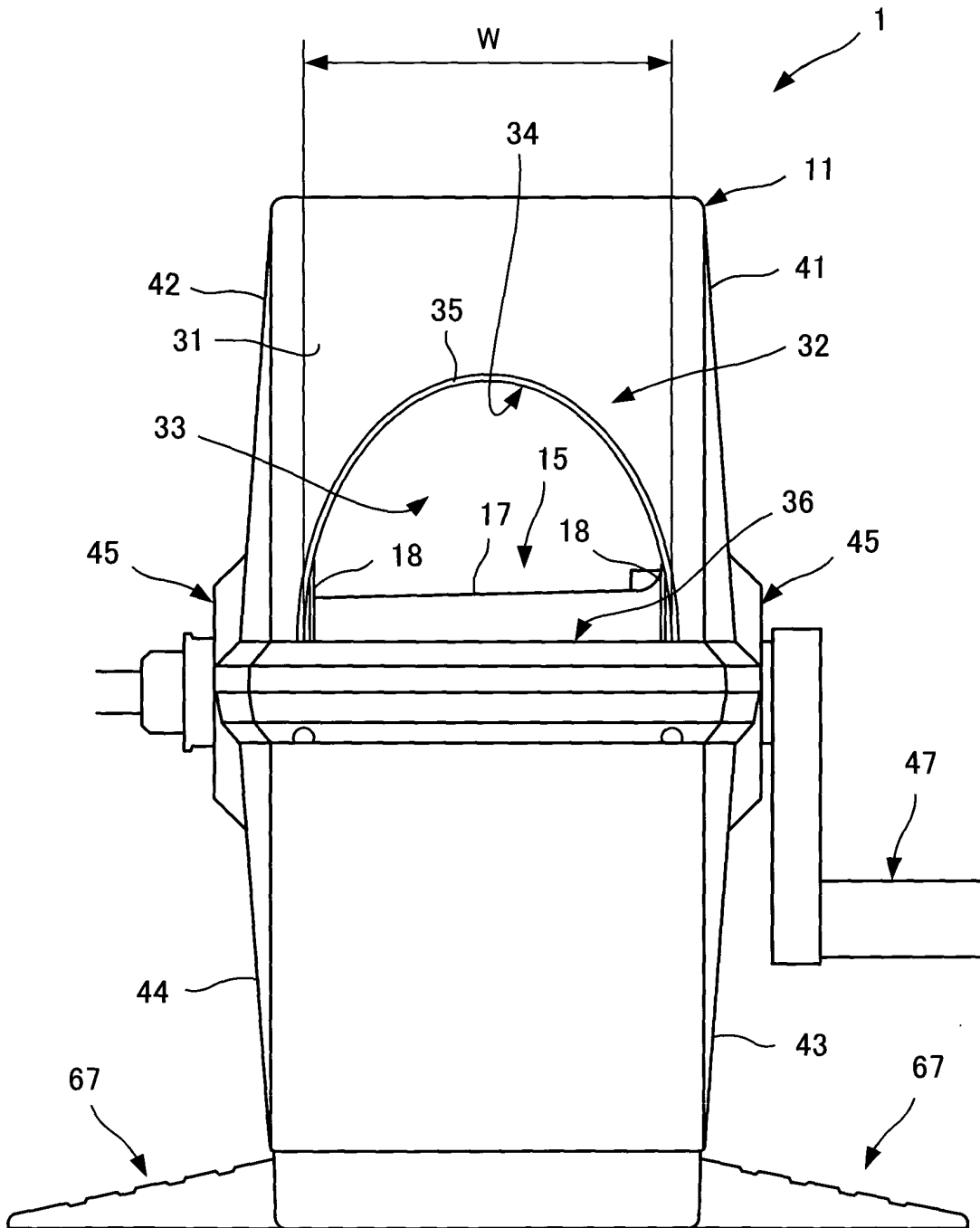

FIG. 7

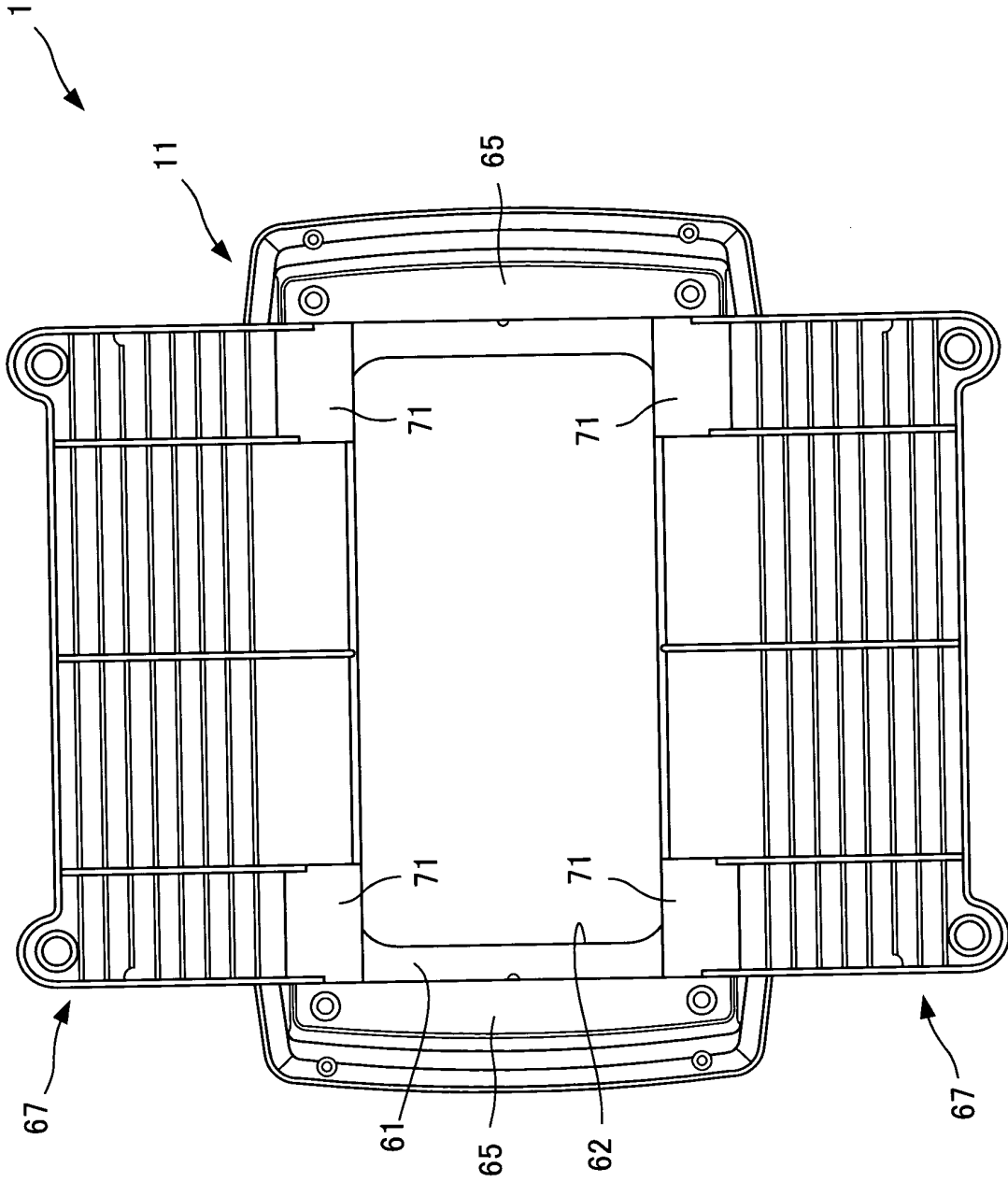

FIG. 8

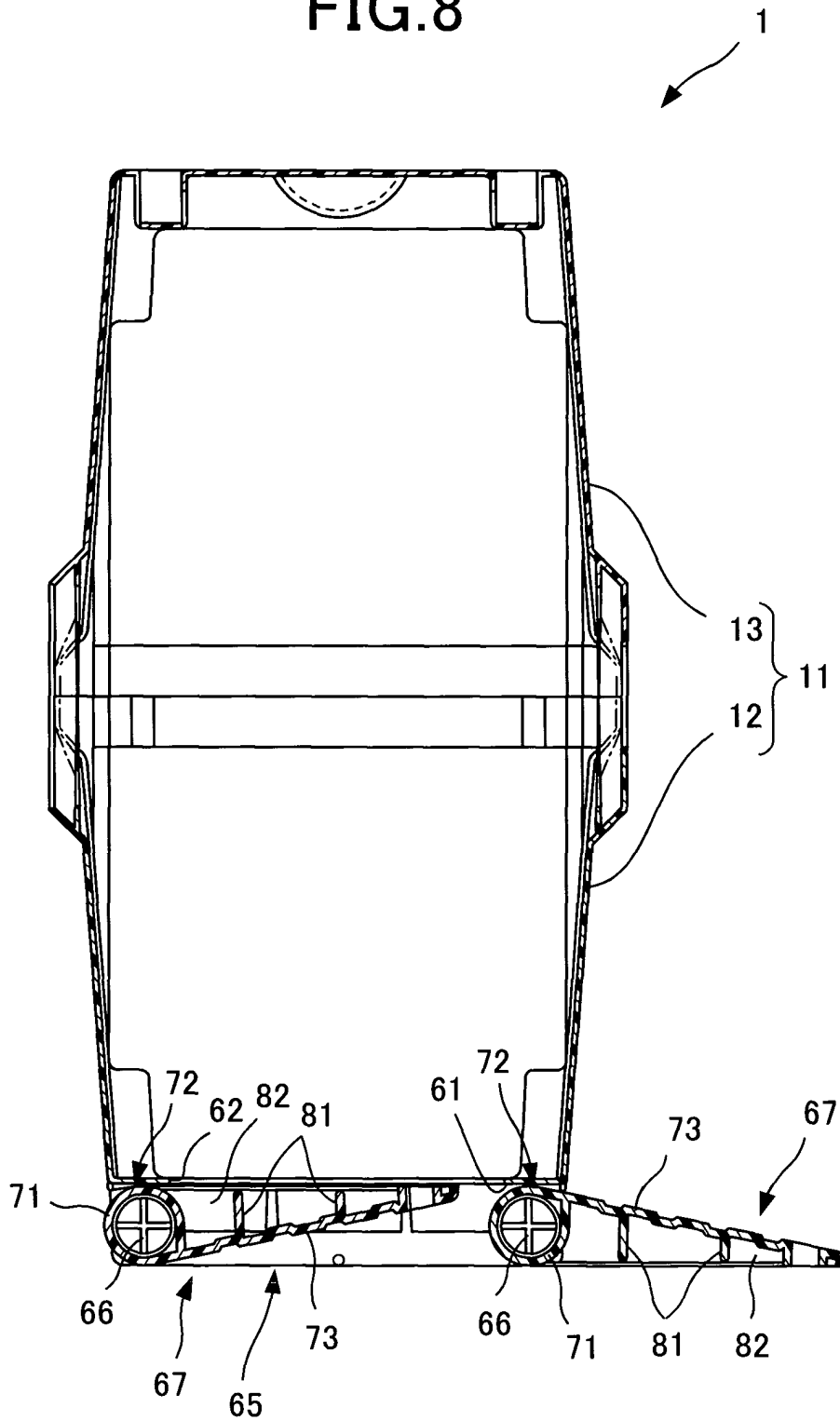

FIG.9

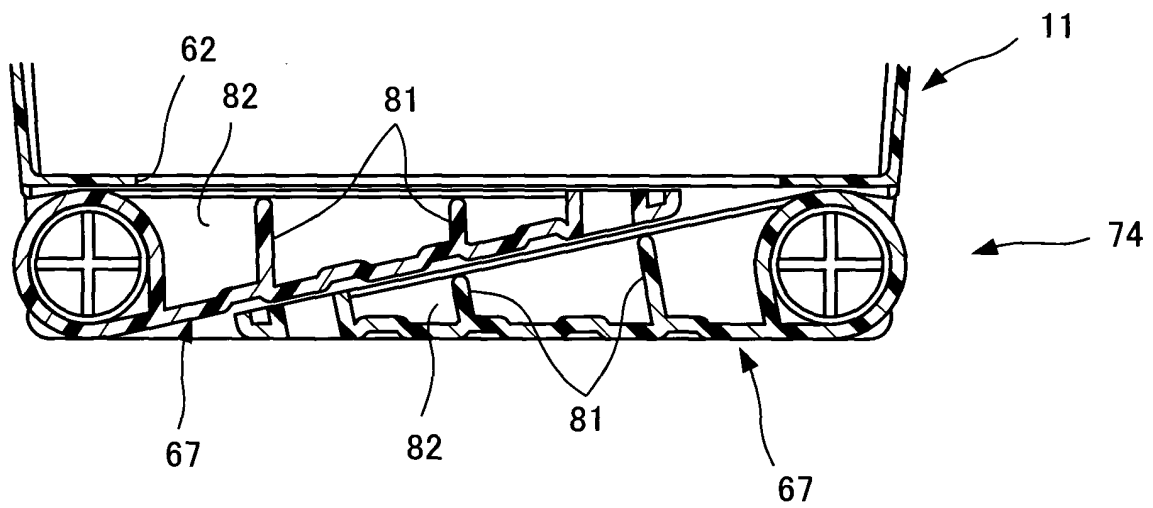

FIG.10

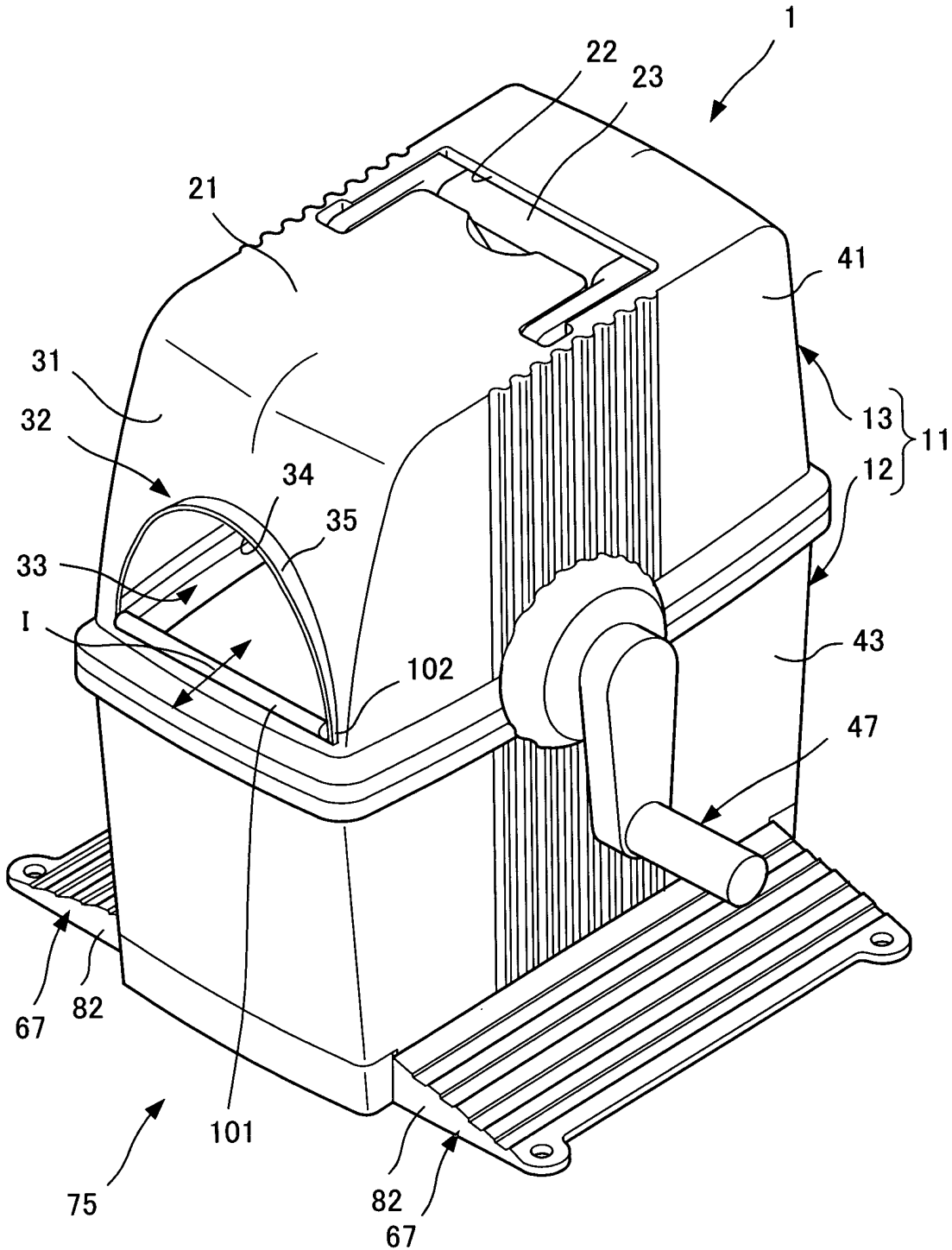

FIG.11

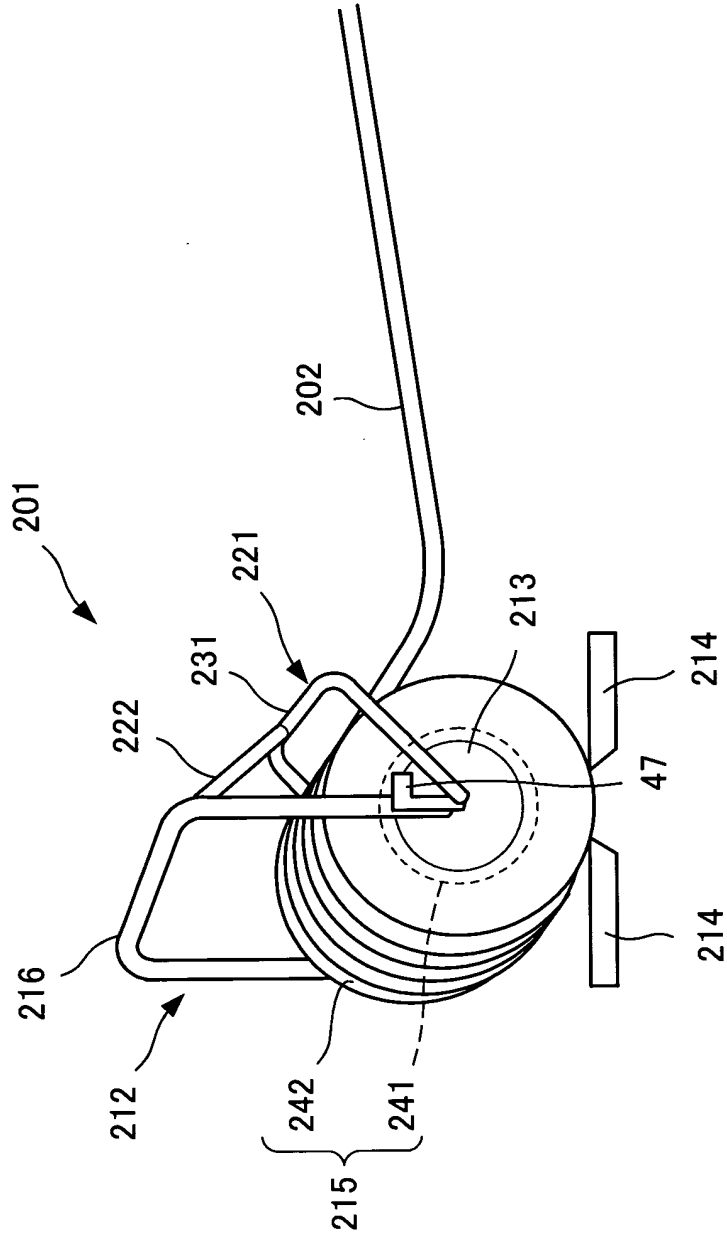

FIG.12

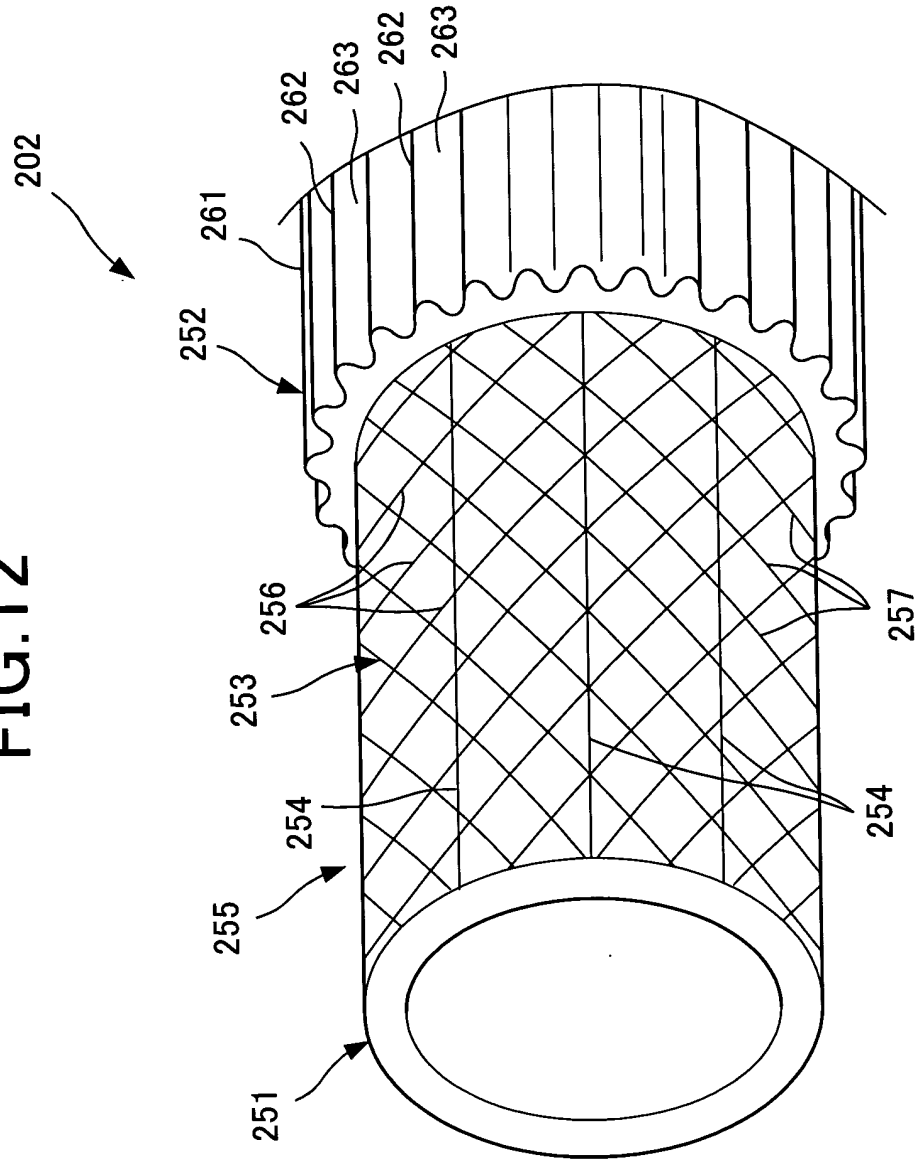

FIG.13A

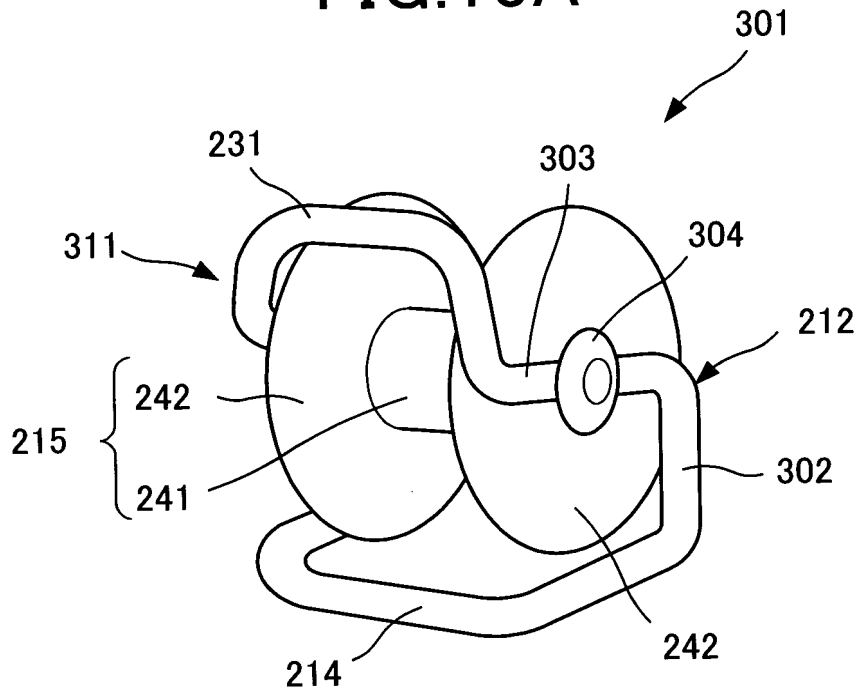

FIG.13B

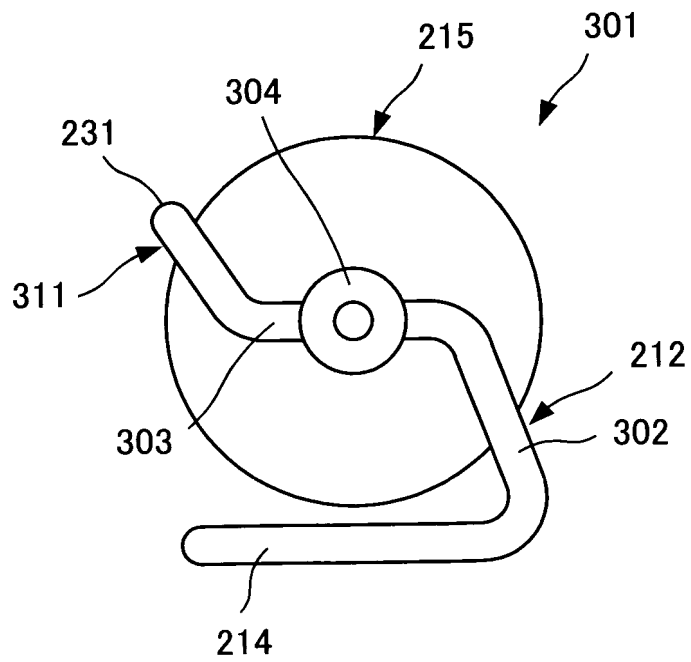

FIG.14A

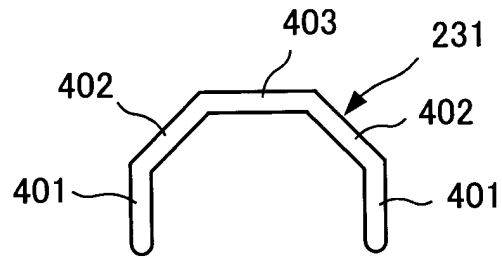

FIG.14B

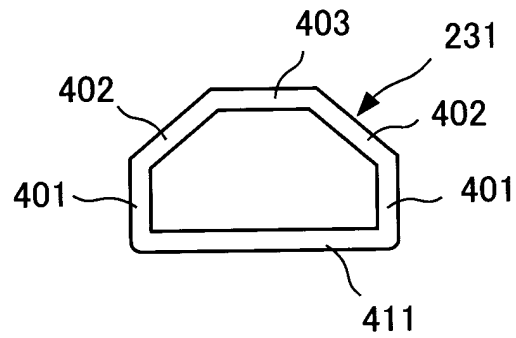

FIG.14C

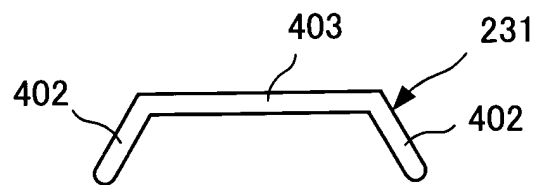

FIG. 15

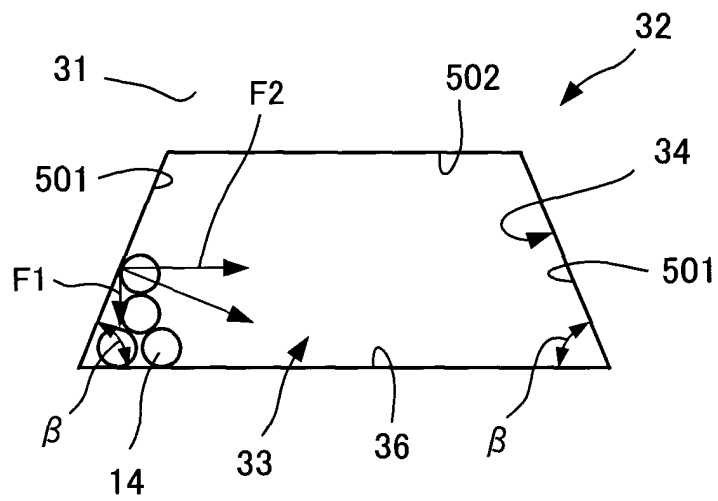

FIG.16

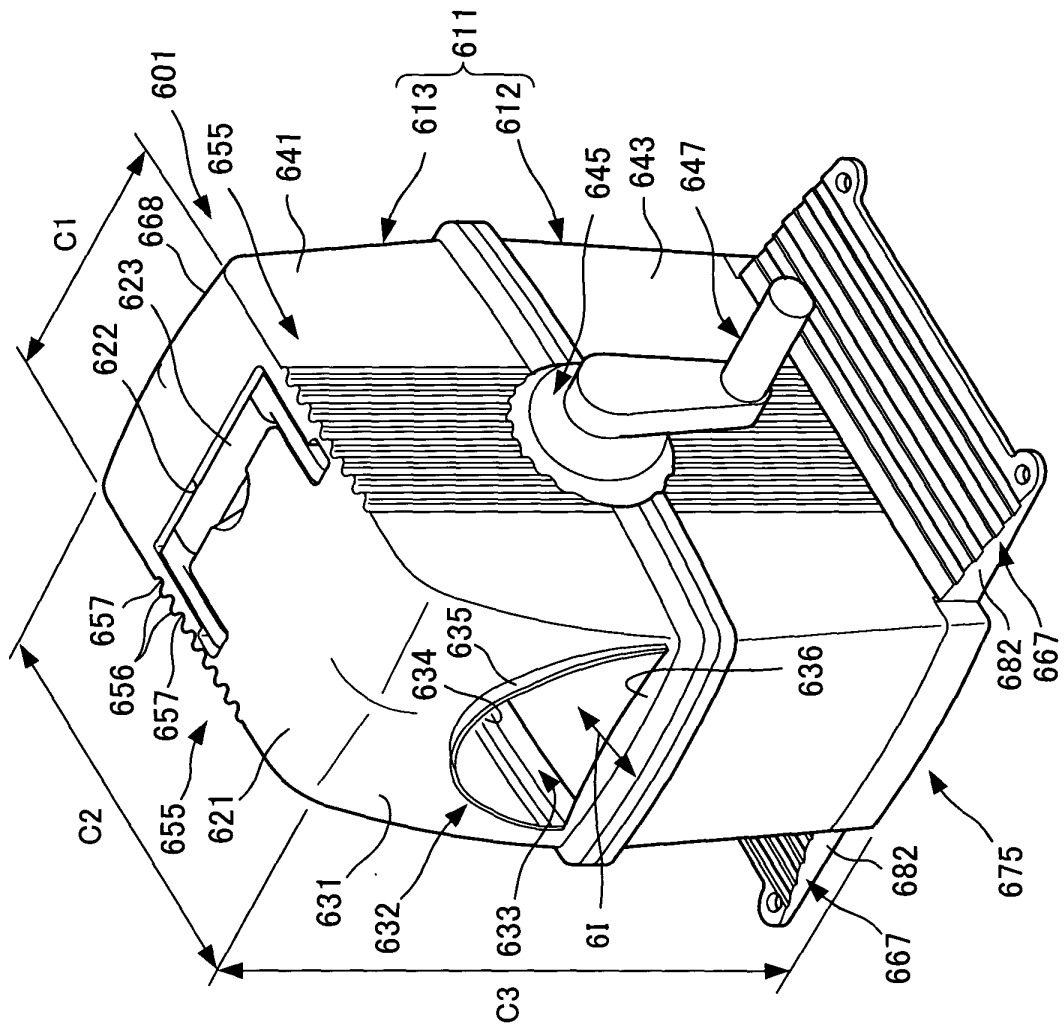

FIG.17

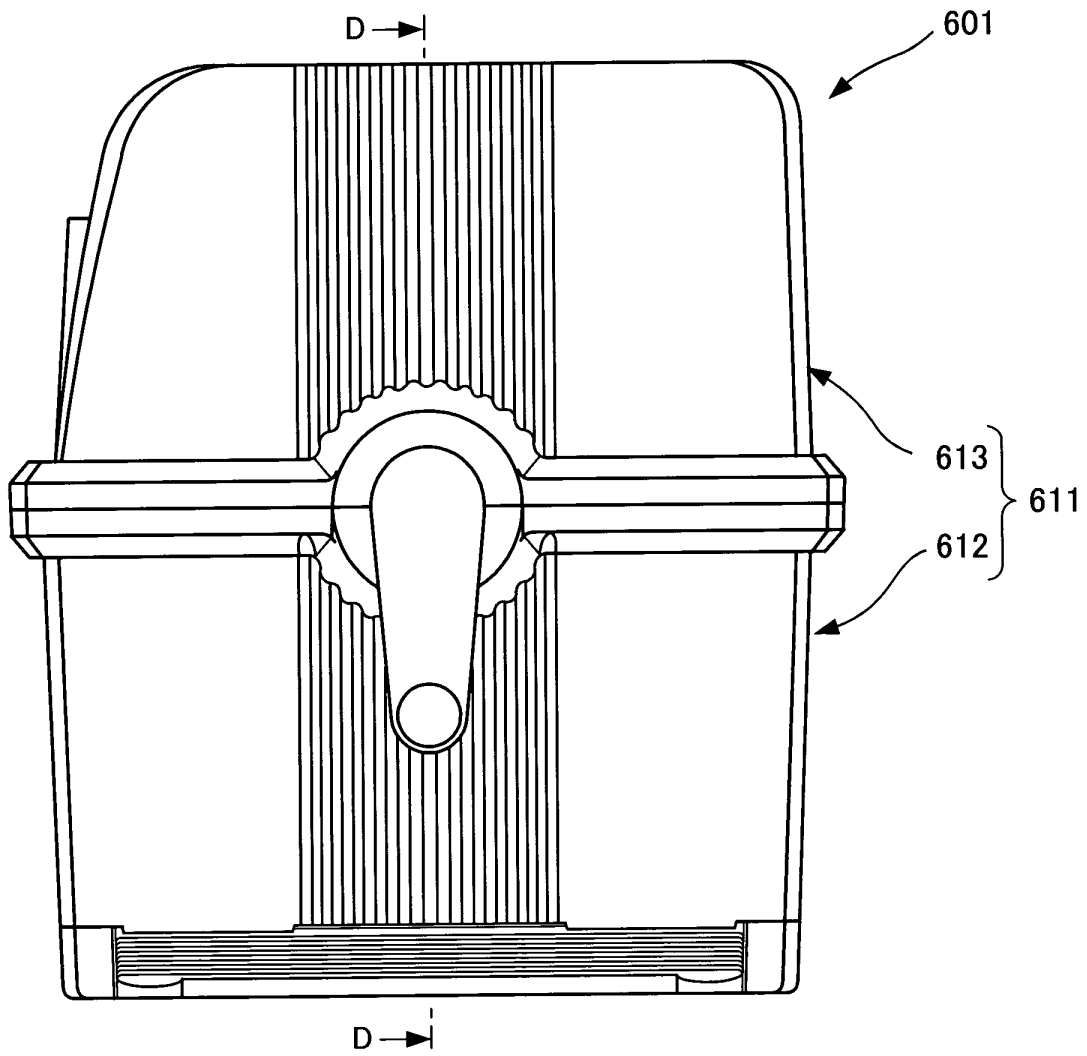

FIG.18

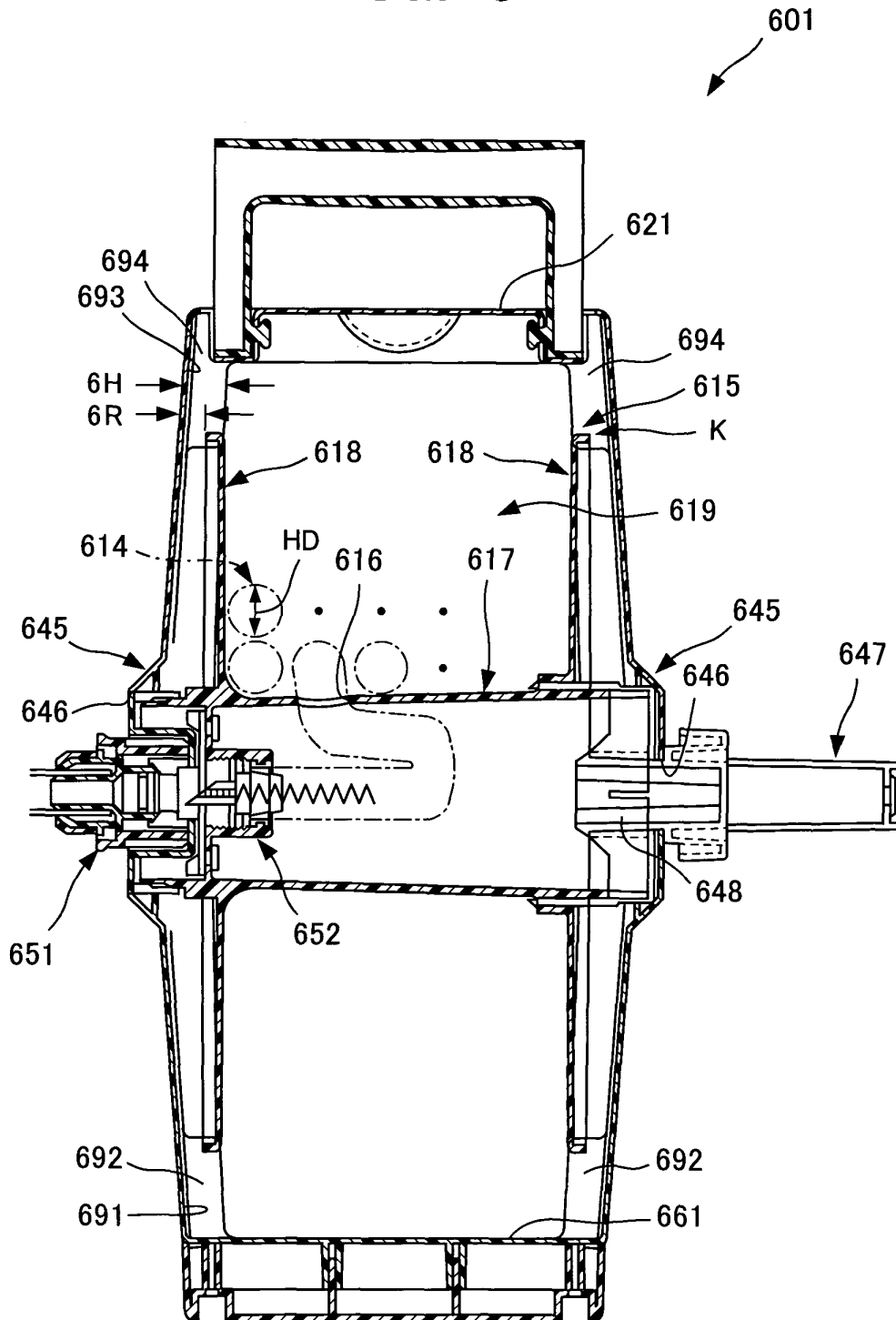

FIG.19

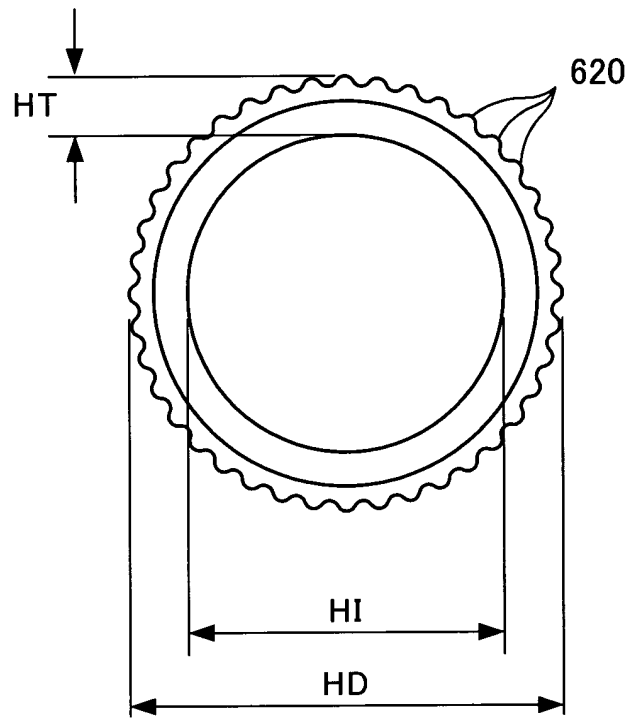

FIG.20

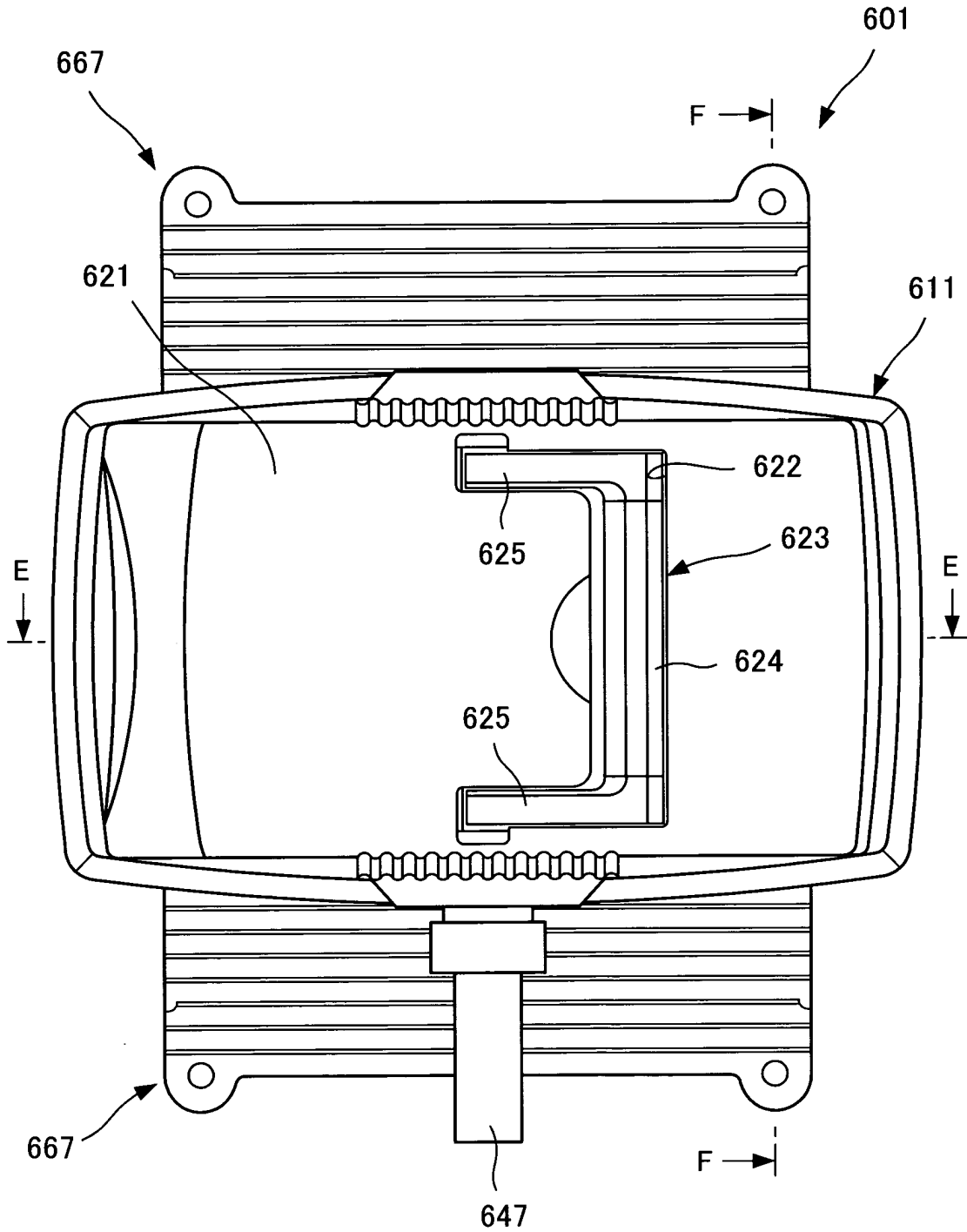

FIG.21

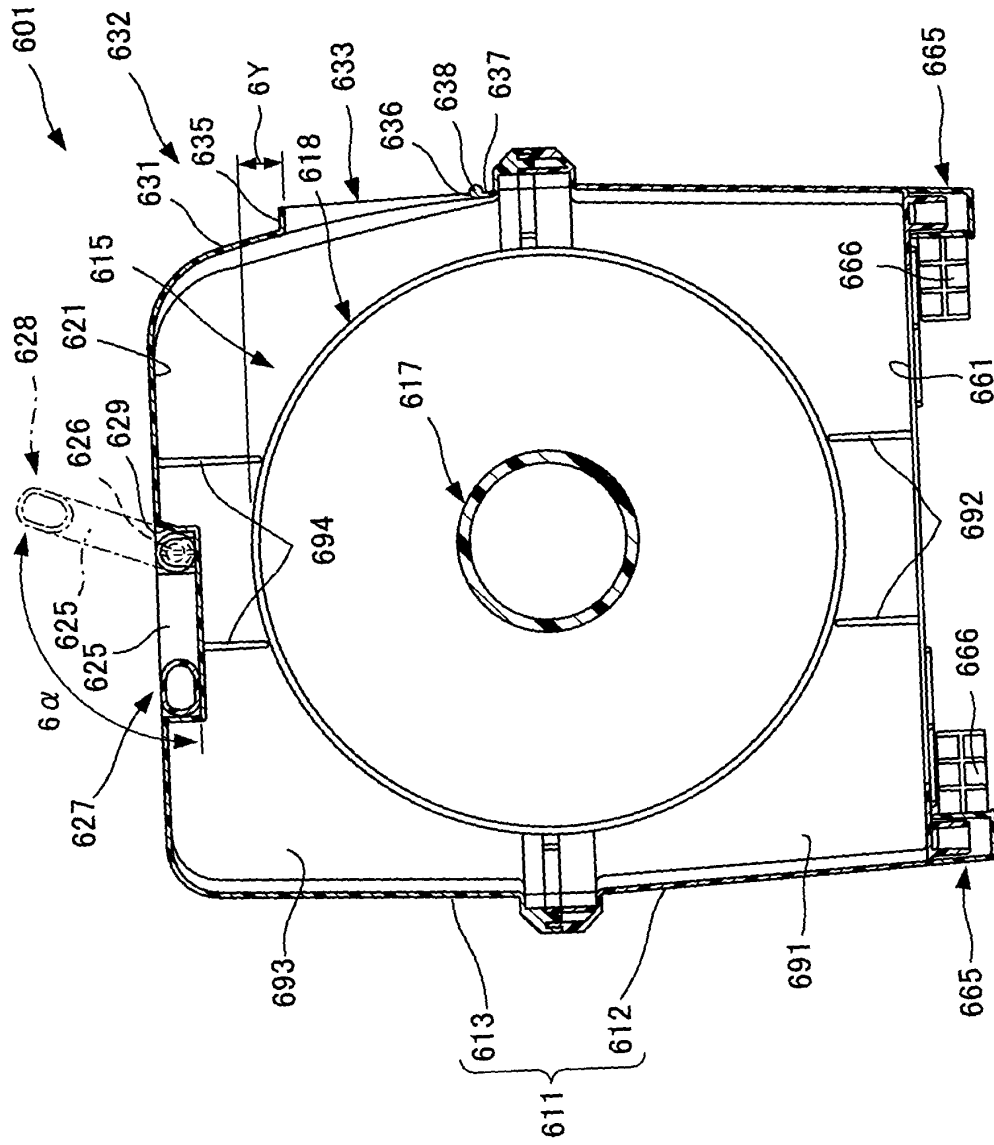

FIG.22

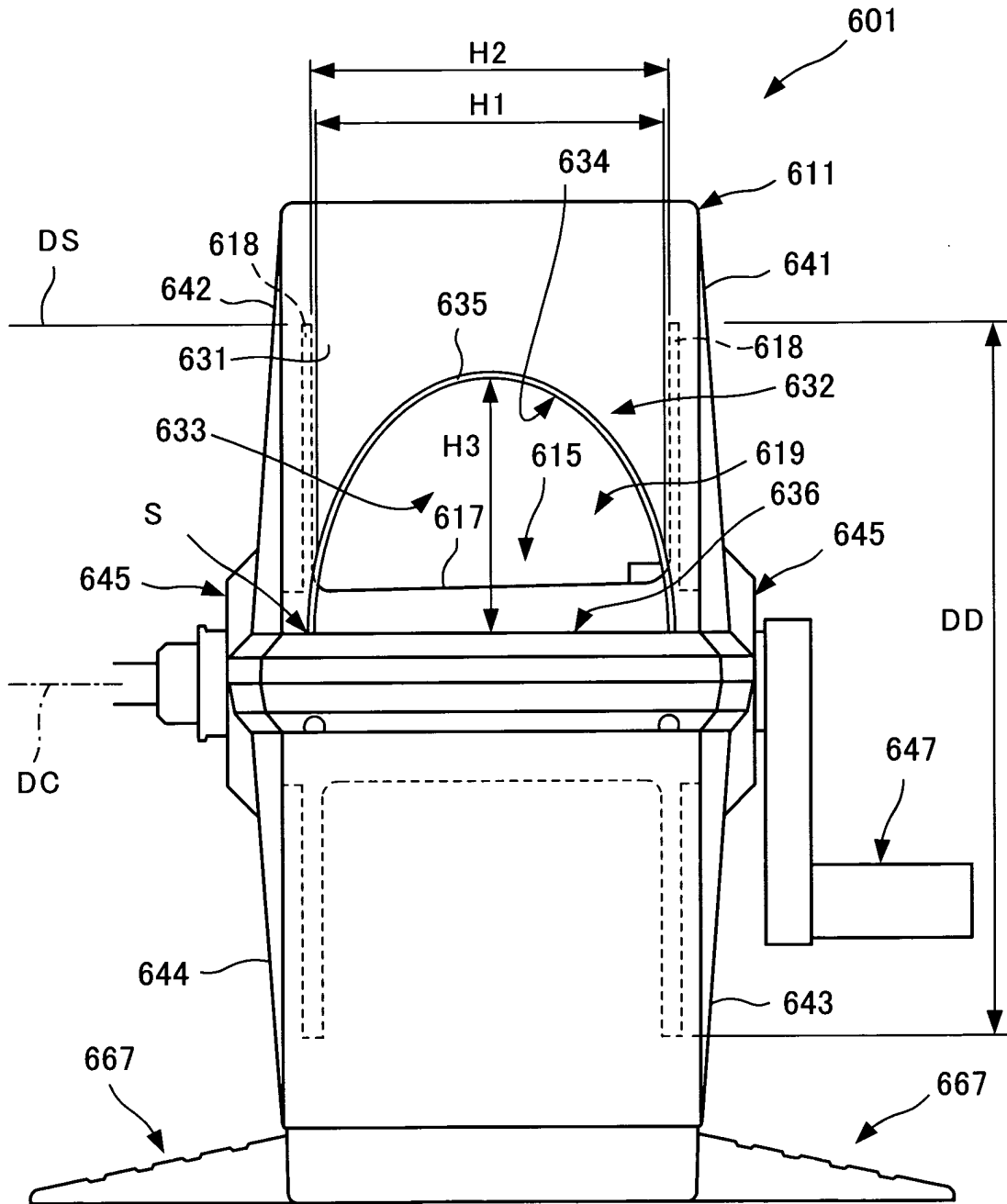

FIG.23

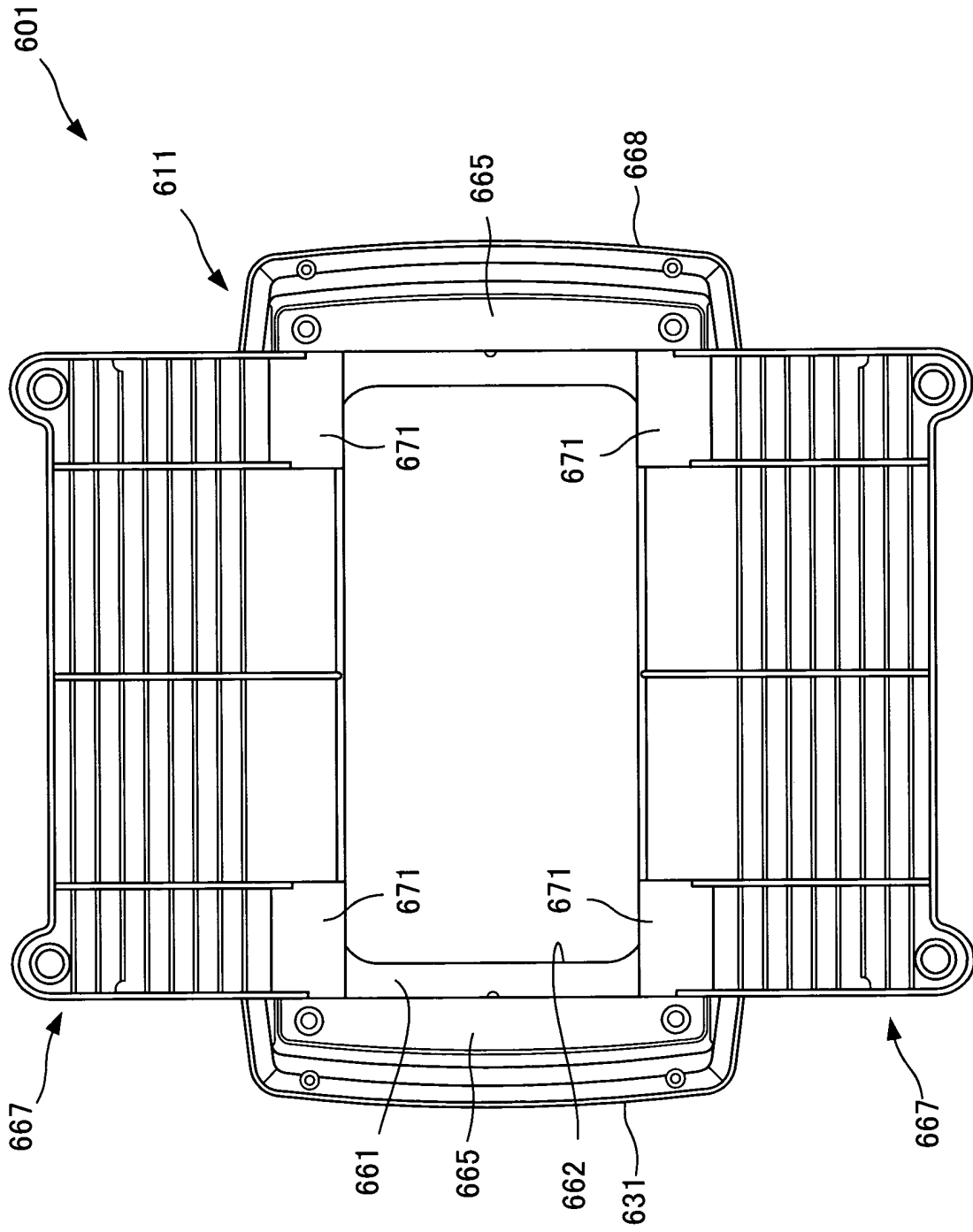

FIG.25

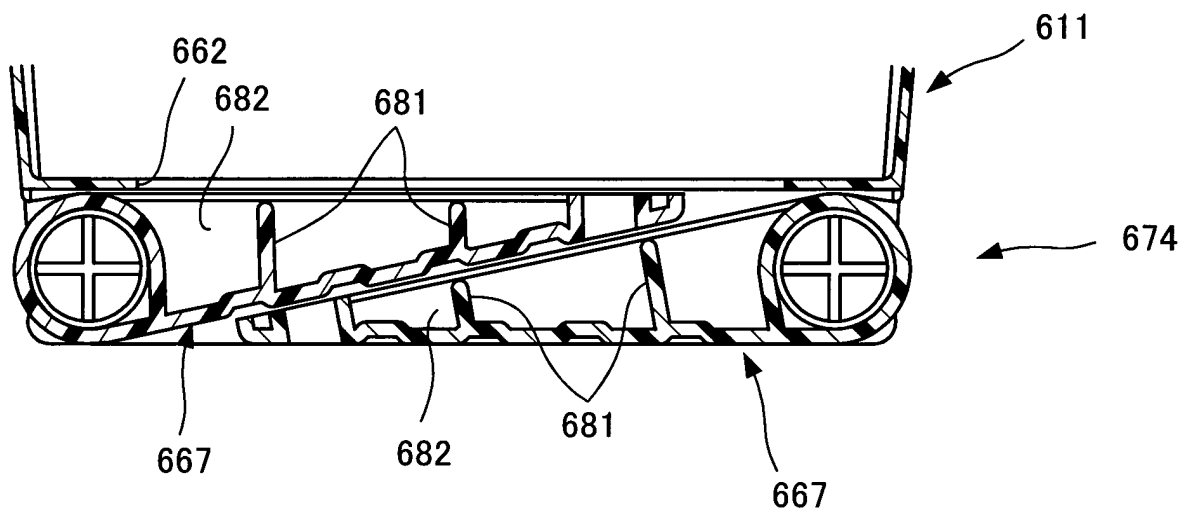

FIG.26

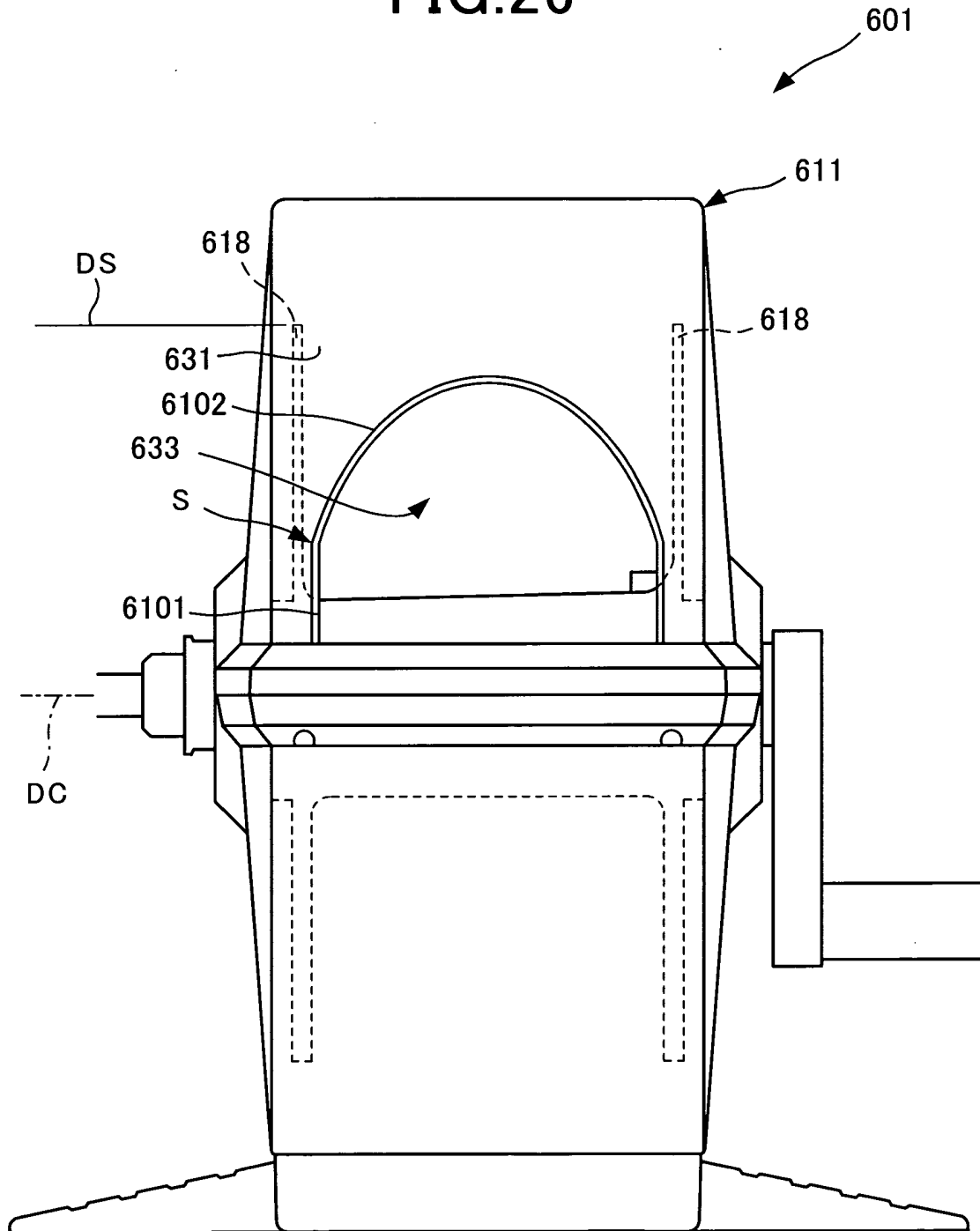

FIG.27A

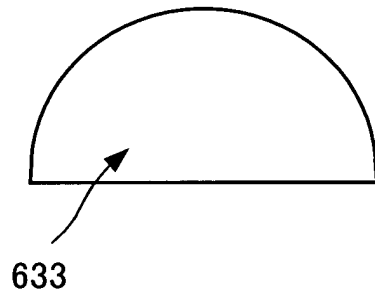

FIG.27B

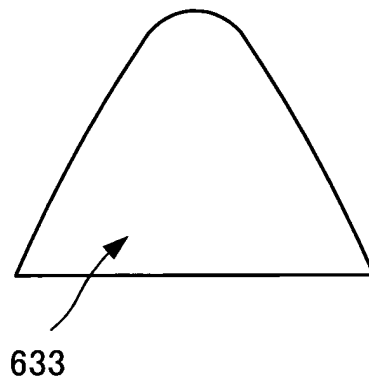

FIG.28A

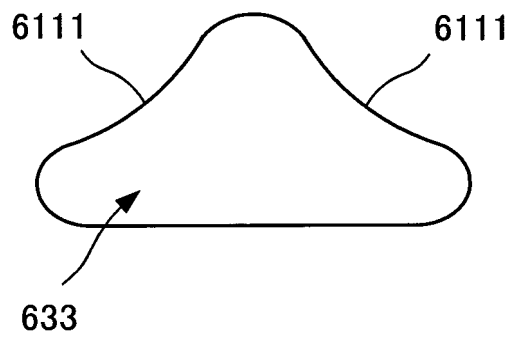
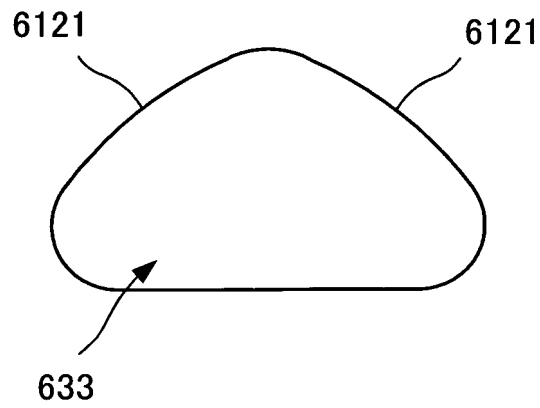

FIG.28B



INTERNATIONAL SEARCH REPORT

International application No.

PCT/JP03/14588

<p>A. CLASSIFICATION OF SUBJECT MATTER Int.Cl⁷ B65H75/40</p> <p>According to International Patent Classification (IPC) or to both national classification and IPC</p>																	
<p>B. FIELDS SEARCHED</p> <p>Minimum documentation searched (classification system followed by classification symbols) Int.Cl⁷ B65H75/40, F16L11/11</p> <p>Documentation searched other than minimum documentation to the extent that such documents are included in the fields searched Jitsuyo Shinan Koho 1922-1996 Toroku Jitsuyo Shinan Koho 1994-2003 Kokai Jitsuyo Shinan Koho 1971-2003 Jitsuyo Shinan Toroku Koho 1996-2003</p> <p>Electronic data base consulted during the international search (name of data base and, where practicable, search terms used)</p>																	
<p>C. DOCUMENTS CONSIDERED TO BE RELEVANT</p> <table border="1"> <thead> <tr> <th>Category*</th> <th>Citation of document, with indication, where appropriate, of the relevant passages</th> <th>Relevant to claim No.</th> </tr> </thead> <tbody> <tr> <td>X Y</td> <td>Microfilm of the specification and drawings annexed to the request of Japanese Utility Model Application No. 19410/1978 (Laid-open No. 122278/1979) (Taiki Kogyo Kabushiki Kaisha), 27 August, 1979 (27.08.79), Page 3, lines 1 to 2; Fig. 1 (Family: none)</td> <td>6, 10, 11 9, 15</td> </tr> <tr> <td>X Y</td> <td>Microfilm of the specification and drawings annexed to the request of Japanese Utility Model Application No. 25401/1982 (Laid-open No. 127060/1983) (Mitsubishi Heavy Industries, Ltd.), 29 August, 1983 (29.08.83), Page 2, lines 12 to 15 (Family: none)</td> <td>7, 8 9, 15</td> </tr> </tbody> </table> <p><input checked="" type="checkbox"/> Further documents are listed in the continuation of Box C. <input type="checkbox"/> See patent family annex.</p> <p>* Special categories of cited documents: "A" document defining the general state of the art which is not considered to be of particular relevance "E" earlier document but published on or after the international filing date "L" document which may throw doubts on priority claim(s) or which is cited to establish the publication date of another citation or other special reason (as specified) "O" document referring to an oral disclosure, use, exhibition or other means "P" document published prior to the international filing date but later than the priority date claimed "T" later document published after the international filing date or priority date and not in conflict with the application but cited to understand the principle or theory underlying the invention "X" document of particular relevance; the claimed invention cannot be considered novel or cannot be considered to involve an inventive step when the document is taken alone "Y" document of particular relevance; the claimed invention cannot be considered to involve an inventive step when the document is combined with one or more other such documents, such combination being obvious to a person skilled in the art "&" document member of the same patent family</p> <table border="1"> <tr> <td>Date of the actual completion of the international search 12 December, 2003 (12.12.03)</td> <td>Date of mailing of the international search report 24 December, 2003 (24.12.03)</td> </tr> <tr> <td>Name and mailing address of the ISA/ Japanese Patent Office</td> <td>Authorized officer</td> </tr> <tr> <td>Facsimile No.</td> <td>Telephone No.</td> </tr> </table>			Category*	Citation of document, with indication, where appropriate, of the relevant passages	Relevant to claim No.	X Y	Microfilm of the specification and drawings annexed to the request of Japanese Utility Model Application No. 19410/1978 (Laid-open No. 122278/1979) (Taiki Kogyo Kabushiki Kaisha), 27 August, 1979 (27.08.79), Page 3, lines 1 to 2; Fig. 1 (Family: none)	6, 10, 11 9, 15	X Y	Microfilm of the specification and drawings annexed to the request of Japanese Utility Model Application No. 25401/1982 (Laid-open No. 127060/1983) (Mitsubishi Heavy Industries, Ltd.), 29 August, 1983 (29.08.83), Page 2, lines 12 to 15 (Family: none)	7, 8 9, 15	Date of the actual completion of the international search 12 December, 2003 (12.12.03)	Date of mailing of the international search report 24 December, 2003 (24.12.03)	Name and mailing address of the ISA/ Japanese Patent Office	Authorized officer	Facsimile No.	Telephone No.
Category*	Citation of document, with indication, where appropriate, of the relevant passages	Relevant to claim No.															
X Y	Microfilm of the specification and drawings annexed to the request of Japanese Utility Model Application No. 19410/1978 (Laid-open No. 122278/1979) (Taiki Kogyo Kabushiki Kaisha), 27 August, 1979 (27.08.79), Page 3, lines 1 to 2; Fig. 1 (Family: none)	6, 10, 11 9, 15															
X Y	Microfilm of the specification and drawings annexed to the request of Japanese Utility Model Application No. 25401/1982 (Laid-open No. 127060/1983) (Mitsubishi Heavy Industries, Ltd.), 29 August, 1983 (29.08.83), Page 2, lines 12 to 15 (Family: none)	7, 8 9, 15															
Date of the actual completion of the international search 12 December, 2003 (12.12.03)	Date of mailing of the international search report 24 December, 2003 (24.12.03)																
Name and mailing address of the ISA/ Japanese Patent Office	Authorized officer																
Facsimile No.	Telephone No.																

INTERNATIONAL SEARCH REPORT

International application No.

PCT/JP03/14588

C (Continuation). DOCUMENTS CONSIDERED TO BE RELEVANT		
Category*	Citation of document, with indication, where appropriate, of the relevant passages	Relevant to claim No.
Y	JP 2002-206678 A (Kabushiki Kaisha Toyokkusu), 26 July, 2002 (26.07.02), Par. No. [0016] (Family: none)	9
Y	JP 2001-48425 A (Kazunori ABE), 20 February, 2001 (20.02.01), Par. Nos. [0009], [0010] (Family: none)	15

Form PCT/ISA/210 (continuation of second sheet) (July 1998)