



(11) **EP 1 566 357 B1**

(12) **EUROPEAN PATENT SPECIFICATION**

(45) Date of publication and mention of the grant of the patent:  
**17.08.2011 Bulletin 2011/33**

(51) Int Cl.:  
**B66B 5/00 (2006.01) B66B 11/02 (2006.01)**

(21) Application number: **02783621.2**

(86) International application number:  
**PCT/JP2002/012326**

(22) Date of filing: **26.11.2002**

(87) International publication number:  
**WO 2004/048245 (10.06.2004 Gazette 2004/24)**

(54) **ELEVATOR EQUIPMENT**  
**AUFZUGSEINRICHTUNG**  
**EQUIPEMENT D'ASCENSEUR**

(84) Designated Contracting States:  
**DE**

• **ISHII, Toshiaki**  
**Chiyoda-ku,**  
**Tokyo 100-8310 (JP)**

(43) Date of publication of application:  
**24.08.2005 Bulletin 2005/34**

(74) Representative: **Wiedemann, Peter et al**  
**Hoffmann - Eitle**  
**Patent- und Rechtsanwälte**  
**Arabellastrasse 4**  
**81925 München (DE)**

(73) Proprietor: **MITSUBISHI DENKI KABUSHIKI KAISHA**  
**Chiyoda-ku**  
**Tokyo 100-8310 (JP)**

(72) Inventors:  
• **YASUE, Masanori**  
**Chiyoda-ku,**  
**Tokyo 100-8310 (JP)**

(56) References cited:  
**EP-A1- 1 026 116 WO-A1-01/81229**  
**DE-A1- 10 104 351 JP-A- 6 278 973**  
**JP-A- 9 263 372 JP-A- 2002 114 462**  
**JP-A- 2002 173 277**

**EP 1 566 357 B1**

Note: Within nine months of the publication of the mention of the grant of the European patent in the European Patent Bulletin, any person may give notice to the European Patent Office of opposition to that patent, in accordance with the Implementing Regulations. Notice of opposition shall not be deemed to have been filed until the opposition fee has been paid. (Art. 99(1) European Patent Convention).

**Description**

## Technical Field

**[0001]** The present invention relates to an elevator apparatus in which maintenance and inspection work on equipment disposed within a hoistway is performed from above a car.

Background Art An elevator apparatus according to the preamble of claim 1 is already known

**[0002]** e.g. from JP-A-09263372. With a conventional elevator apparatus in which equipment is disposed in an upper portion within a hoistway, a worker performs maintenance and inspection work from above a car. A space for performing maintenance and inspection work therefore must be secured in the upper portion within the hoistway, and accordingly clearance size (overhead size) in the upper portion of the hoistway becomes larger due to this space. That is, the work space above the car wastes space in the overall elevator apparatus.

**[0003]** Further, an inspection door is provided in a cage wall with a conventional elevator apparatus as disclosed in JP 2001-106459 A. Equipment within a hoistway is maintained and inspected from within the cage by opening the inspection door.

**[0004]** However, since the inspection door is provided in the cage wall with this type of elevator apparatus, the designability within the cage is reduced accordingly. Further, work can only be performed on equipment that is facing the inspection door, and the work is limited. In addition, it is necessary to provide a plurality of inspection doors in order to perform work on equipment disposed at different locations. This further reduces the designability. Still further, it is necessary to form the inspection door in an upper portion of the cage wall for cases where the equipment is disposed in the vicinity of the highest portion within the hoistway. Footholds such as a stepladder must thus be provided separately.

## Disclosure of the Invention

**[0005]** The present invention has been made in order to solve problems like those described above. An object of the present invention is to obtain an elevator apparatus in which maintenance and inspection work can be performed easily from above a car on equipment within a hoistway, and moreover, in which reduced designability within the car can be prevented while the overhead size of the hoistway can be reduced.

**[0006]** According to the present invention, an elevator apparatus comprises a cage that is raised and lowered within a hoistway. The cage has a cage main body that is provided with a cage entrance, and a ceiling portion that is provided in an upper end portion of the cage main body. The ceiling portion is upwardly and downwardly movable between a normal operating position that is lo-

cated at the upper end portion of the cage main body, and a getting on/off position that is located lower than the normal operating position within the cage main body. The getting on/off position is provided for moving from a landing hall, through the entrance, and onto the ceiling portion. The landing hall is provided with a landing hall side control switch portion for making the ceiling portion move upward and downward.

## 10 BRIEF DESCRIPTION OF THE DRAWINGS

**[0007]**

15 Fig. 1 is a perspective view that shows an elevator apparatus according to Embodiment 1 of the present invention;

Fig. 2 is a perspective view that shows a state when maintenance and inspection work are being performed on the elevator apparatus of Fig. 1;

20 Fig. 3 is an explanatory diagram that shows an elevator mechanism of the ceiling portion of Fig. 1;

Fig. 4 is a cross sectional view of main portions of the elevator apparatus of Fig. 2;

25 Fig. 5 is a cross sectional view that shows states of getting on and off, the ceiling portion of the elevator apparatus of Fig. 4; and

Fig. 6 is a front view that shows a wire winding apparatus of Fig. 5.

## 30 Best Mode for carrying out the Invention

**[0008]** Preferable embodiments of the present invention are explained below while referring to the drawings.

## 35 Embodiment 1

**[0009]** Fig. 1 is a perspective view that shows an elevator apparatus according to Embodiment 1 of the present invention, and Fig. 2 is a perspective view that shows a state when maintenance and inspection work are being performed on the elevator apparatus of Fig. 1.

40 **[0010]** In the figures, a pair of car guide rails 2 and a pair of counter weight guide rails 3 are disposed within a hoistway 1. A car 4 is raised and lowered within the hoistway 1, guided by the car guide rails 2. A counterweight 5 is raised and lowered within the hoistway 1, guided by the counterweight guide rails 3.

50 **[0011]** A supporting member 6 is fixed to upper end portions of the counterweight guide rails 3. The supporting member 6 supports a driving apparatus (hoisting machine) 7 that raises and lowers the car 4 and the counterweight 5. The driving apparatus 7 has a driving apparatus main body 8 that includes a motor, and a driving sheave 9 that is rotated by the driving apparatus main body 8.

55 **[0012]** A plurality of main ropes 10 are wound around the driving sheave 9. The car 4 and the counterweight 5 are suspended down within the hoistway 1 by the main

ropes 10. A pair of car suspension sheaves 11, around which the main ropes 10 are wound, are provided in a lower end portion of the car 4. A pair of counterweight suspension sheaves 12, around which the main ropes 10 are wound, are provided in an upper end portion of the counterweight 5.

**[0013]** A first rope fastening portion 13 is fixed to an upper end portion of one of the car guide rail's 2. A second rope fastening portion 14 is fixed in the vicinity of upper end portions of the counterweight guide rails 3. The main ropes 10 each have a first end portion 10a that is connected to the first rope fastening portion 13, and a second end portion 10b that is connected to the second rope fastening portion 14. Further, the main ropes 10 are wound, in order from the first end portion 10a, around the car suspension sheave 11, the driving sheave 9, and the counterweight suspension sheave 12, leading to the second end portion 10b.

**[0014]** A control panel 15 that controls operation of the driving apparatus 7 is fixed to an upper portion of the other car guide rail 2.

**[0015]** The car 4 has a car frame (not shown) and a cage 16 that is supported by the car frame. The cage 16 has a cage main body 17 in which a cage entrance 17a is provided, a ceiling portion 18 that is provided in an upper portion of the cage main body 17, a car door 19 that opens and closes the car entrance 17a, and a door apparatus 20 that supports, and opens and closes, the car door 19.

**[0016]** Further, the cage main body 17 has a cage floor (bottom surface), front surface, rear surface, left side surface, and right side surface. The car entrance 17a is provided in the front surface of the cage main body 17.

**[0017]** The ceiling portion 18 is upwardly and downwardly movable within a space between a normal operating position (Fig. 1) that is located at an upper end portion of the cage main body 17, a maintenance work position (Fig. 2) that is located lower than the normal operating position within the cage main body 17, and a getting on/off position (Fig. 5) that is located lower than the maintenance work position within the cage main body 17. That is, the ceiling portion 18 also serves as a work floor. Further, the height of the maintenance work position is adjustable according to the height of a worker, the height of equipment to be worked on (such as the driving apparatus 7 or the control panel 15), and the like.

**[0018]** Fig. 3 is an explanatory diagram that shows an elevator mechanism of the ceiling portion 18 of Fig. 1. In the figure, freely rotatable first to fourth cage main body pulleys 21 to 24 are respectively disposed in the four corners of the upper end portion of the cage main body 17. Freely rotatable first to fourth ceiling pulleys 25 to 28 are respectively disposed in the four corners of the ceiling portion 18.

**[0019]** A wire rope 29 is wound around the first to the fourth cage main body pulleys 21 to 24, and the first to the fourth ceiling portion pulleys 25 to 28. An electrically driven winding apparatus 30 that is an apparatus for mov-

ing the ceiling portion 18 upward and downward is mounted on the door apparatus 20. A winding apparatus 34 has an electric motor (not shown). Winding and feeding of the wire rope 29 is performed by a driving force of the electric motor.

**[0020]** The wire rope 29 is wound, in order from one end portion thereof, around the third cage main body pulley 23, the third ceiling portion pulley 27, the second ceiling portion pulley 26, the second cage main body pulley 22, the first cage main body pulley 21, the first ceiling portion pulley 25, the fourth ceiling portion pulley 28, and the fourth cage main body pulley 24. Both end portions are wound by the winding apparatus 34. The ceiling portion 18 moves downward by feeding out the wire rope 29 from the winding apparatus 30, and the ceiling portion 18 moves upward by winding the wire rope into the winding apparatus 30.

**[0021]** A protective member 31 that prevents the inner wall surfaces from being damaged by the upward and downward motion of the ceiling portion 18 is disposed on an end surface of the ceiling portion 18 that faces an inner wall surface of the cage main body 17. For example, a cloth made of felt or the like, a roller that moves by rolling along the inner wall surface of the cage main body 17, and the like can be used as the protective member 31.

**[0022]** Fig. 4 is a cross sectional view of main portions of the elevator apparatus of Fig. 2, and Fig. 5 is a cross sectional view that shows states of getting on and off, the ceiling portion of the elevator apparatus of Fig. 4. In the figures, movement between a landing hall 32 and the ceiling portion 18 becomes possible by lowering the ceiling portion 18 to a getting on/off position. Further, it also becomes possible to adjust the height of the getting on/off position to a height at which movement of a worker, and the carrying in and out of tools, are easy.

**[0023]** A landing hall operation panel 33 is provided in the landing hall 32. The landing hall operation panel 33 has a case 34 that is provided in a wall of the landing hall 32, a cover 35 that is attached to the case 34 in a freely attachable and detachable manner, and a landing hall call button 36 that is electrically connected to the control panel 15. Information on operation of the landing hall call button 36 is transmitted to the control panel 15. It should be noted that Fig. 5 shows a state where the cover 35 is detached from the case 34.

**[0024]** A landing hall side operation switch portion 37 for moving the ceiling portion 18 upward and downward is housed in the case 34. Operation wiring (not shown) used for signal transfer to the winding apparatus 30 is connected to the landing hall side operation switch portion 37. The winding apparatus 30 performs wind-up and feed-out of the wire rope 29 in accordance with operations of the landing hall side operation switch portion 37. The ceiling portion 18 thus moves upward and downward.

**[0025]** A ceiling portion side operation switch portion 39 for moving the ceiling portion 18 upward and downward is provided in the ceiling portion 18 separately from

the landing hall side operation switch portion 37. Operation wiring 40 (operation cable) used for transferring signals to the winding apparatus 30 is connected to the ceiling portion side operation switch portion 39. The ceiling portion 18 is also moved upward and downward by operating the ceiling portion side operation switch portion 39.

**[0026]** Further electric devices 41 such as light fixtures and ventilation apparatuses are supported by the ceiling portion 18.

**[0027]** Electric wiring 42 (electric cable) used for electric power supply and control is connected to the electric devices 41. A wire winding apparatus 43 that winds the operation wiring 40 and electric wiring 42 is attached in the upper end portion of the cage main body 17.

**[0028]** Fig. 6 is a front view that shows the wire winding apparatus 43 of Fig. 5. In the figure, the wire winding apparatus 43 has a support portion 44 that is fixed to the upper end portion of the cage main body 17, a shaft 45 that is fixed to, and supported horizontally by, the support portion 44, a winding wheel 46 that is rotatably supported by the shaft 45, and a spiral spring 47 that is an elastic member, one end portion thereof connected to the shaft 45 and another end portion thereof connected to the winding wheel 46.

**[0029]** The operation wiring 40 and electric wiring 42 are wound around the winding wheel 46. The winding wheel 46 is urged by the spiral spring 47 in a direction for winding the operation wiring 40 and electric wiring 42. The operation wiring 40 and electric wiring 42 are wound by the wire winding apparatus 43 as the ceiling portion 18 ascends. The operation wiring 40 and electric wiring 42 are fed out from the wire winding apparatus 43, against the urging force of the spiral spring 47, as the ceiling portion 18 descends. That is, the length of the portion of the operation wiring 40 between the ceiling portion side operation switch portion 39 and the wire winding apparatus 43, and the length of the portion of electric wiring 42 between the electric devices 41 and the wire winding apparatus 43, are each regulated by the wire winding apparatus 43 according to upward and downward motion of the ceiling portion 18.

**[0030]** Operation is explained next. During normal operation, the ceiling portion 18 is at a normal operation position. During maintenance and inspection, the car 4 is moved to the uppermost floor, and then a worker at the landing hall 32 removes the cover 35 from the landing hall operation panel 33, and operates the landing hall side operation switch portion 37. The ceiling portion 18 is thus lowered to the getting on/off position. During this time, the operation wiring 40 and electric wiring 42 are fed out from the wire winding apparatus 43, against the urging force of the spiral spring 47.

**[0031]** When the ceiling portion 18 stops at the getting on/off position, the worker moves from the landing hall 32 onto the ceiling portion 18. When it is necessary to carry in equipment and tools, work for carrying in the equipment and tools is performed from the landing hall

32.

**[0032]** The ceiling portion 18 is then raised to the maintenance work position by the worker on the ceiling portion 18 operating the ceiling portion side operation switch portion 39. After the ceiling portion 18 is stopped at the maintenance work position, maintenance and inspection work on equipment such as the driving apparatus 7 and the control panel 15, is performed by the worker on the ceiling portion 18. After the work is completed, the ceiling portion 18 is returned to its normal operating position by reversing the procedures described above.

**[0033]** With this kind of elevator apparatus, it becomes possible to move the ceiling portion 18 upward and downward between the normal operating position and the getting on/off position. In addition, the landing hall side operation switch portion 37 for moving the ceiling portion 18 upward and downward is provided at the landing hall 32. It is therefore easy to perform upward and downward movement of the ceiling portion 18 from the landing hall 32, it is easy for the worker to move between the landing hall 32 and the ceiling portion 18, and it is easy to carry in and carry out tools. Further, by stopping the ceiling portion 18 at the maintenance work position located between the normal operating position and the getting on/off position, maintenance and inspection work can be easily carried out on the equipment within the hoistway 1 from above the car 4. Moreover, reductions in designability within the cage 16 can be prevented, and the overhead size of the hoistway 1 can be made smaller. In addition, it is not necessary to provide a separate work stand within the cage 16.

**[0034]** Further, the landing hall operation panel 33 that has the landing hall call button 36 is provided in the landing hall 32, and the landing hall side operation switch portion 37 is housed within the landing hall operation panel 33. Reductions in designability of the landing hall 32 can therefore be prevented. Furthermore, it is not necessary to provide a new box for housing the landing hall side operation switch portion 37.

**[0035]** In addition, the ceiling portion side operation switch portion 39 for moving the ceiling portion 18 upward and downward is provided in the ceiling portion 18 separately from the landing hall side operation switch portion 37. The ceiling portion 18 can therefore be moved upward and downward by a worker on the ceiling portion 18, and operational efficiency can thus be improved.

**[0036]** Additionally, the electric devices 41 is supported by the ceiling portion 18. The length of the portion of electric wiring 42, which is connected to the electric devices 41, between the electric devices 41 and the wire winding apparatus 43 is adjusted by the wire winding apparatus 43 winding electric wiring 42 according to upward and downward movement of the ceiling portion 18. It is therefore unnecessary to provide a connector portion to electric wiring 42 for connection and disconnection thereof. Accordingly, the time and labor involved in connecting and disconnecting the connector portion can be eliminated, and operational efficiency can thus be im-

proved. Further, slack in electric wiring 42 can be reduced, and obstructions to the upward and downward movement of the ceiling portion 18 caused by electric wiring 42 can be prevented.

**[0037]** Still further, as the ceiling portion side operation switch portion 39 is connected to the operation wiring 40 and as the length of the portion of the operation wiring 40 between the ceiling portion side operation switch portion 39 and the wire winding apparatus 43 is adjusted by the wire winding apparatus 43 according to upward and downward movement of the ceiling portion 18, it is therefore unnecessary to provide a connector portion to the operation wiring 40 for connection and disconnection thereof. Accordingly, the time and labor involved in connecting and disconnecting the connector portion can be eliminated, and operational efficiency can thus be increased. Further, slack in the operation wiring 40 can be reduced, and obstructions to the upward and downward motion of the ceiling portion caused by operation wiring 40 can be prevented.

**[0038]** Further, the ceiling portion 18 is suspended by the wire rope 29, and is moved upward and downward by the winding apparatus 30 winding the wire rope 29. Therefore there is no influence on designability within the cage 16. The ceiling portion 18 can be made to move upward and downward by employing a simple structure, and can be stopped and held at a predetermined position. Further, the height of the ceiling portion 18 can be continuously adjusted. The ceiling portion 18 can be stopped at a position suitable for work, and operational efficiency can thus be improved.

**[0039]** In addition, the protective member 31 is disposed in the end surfaces of the ceiling portion 18, opposing the inner wall surfaces of the cage main body 17. The ceiling portion 18 can therefore be made to move smoothly upward and downward, and damage to the inner wall surfaces of the cage main body 17 due to contact with the ceiling portion 18 can be prevented.

**[0040]** Still further, the first to the fourth cage main body pulleys 21 to 24 are each disposed at one of the four corners of the upper end portion of the cage main body 17, and the first to the fourth ceiling portion pulleys 25 to 28 are each disposed at one of the four corners on the ceiling portion 18. The ceiling portion 18 can therefore be stabilized, and made to move upward and downward.

**[0041]** Further, for cases where a handrail is provided on the inner wall surface of the cage main body 17, interference between the ceiling portion 18 and the handrail can be prevented by locating the getting on/off position above the handrail.

**[0042]** It should be noted that, although the ceiling portion 18 is suspended by the wire rope 29 in the example described above, the ceiling portion may also be suspended by using, for example, belts, chains, or the like.

**[0043]** Further, although the ceiling portion 18 is made to move upward and downward by the winding apparatus 30 that winds the wire rope 29, the ceiling portion 18 may also be made to move upward and downward by using,

for example, hydraulic actuators or the like.

**[0044]** In addition, a locking means that regulates the descent of the ceiling portion 18 and is mechanically joined to the ceiling portion 18 when the ceiling portion 18 is in the normal operating position may also be provided between the cage main body 17 and the ceiling portion 18.

**[0045]** Still further, although the entire ceiling portion 18 is made to move upward and downward in the example described above, it is also possible to make only a portion of the ceiling portion 18 move upward and downward.

**[0046]** Further, a lower limit stopping means for automatically stopping the ceiling portion 18 at the getting on/off position may also be provided in the car 4 so that the ceiling portion 18 does not descend further than the getting on/off position.

## 20 Claims

1. An elevator apparatus comprising a cage (16) that is raised and lowered within a hoistway (1), the cage (16) having a cage main body (17) that is provided with a cage entrance (17a), and a ceiling portion (18) that is provided in an upper end portion of the cage main body (17), wherein the ceiling portion (18) is upwardly and downwardly movable between a normal operating position that is located at the upper end portion of the cage main body (17), and a getting on/off position that is located lower than the normal operating position within the cage main body (17), and provided for enabling movement of a worker from a landing hall (32), through the entrance, and onto the ceiling portion (18); **characterized in that:** the landing hall (32) is provided with a landing hall side control switch portion (37) for moving the ceiling portion (18) upward and downward.
2. An elevator apparatus according to claim 1, **characterized in that** the landing hall (32) is further provided with a landing hall operation panel (33) having a landing hall call button (36), and wherein the landing hall side operation switch portion (37) is housed within the operation panel (33).
3. An elevator apparatus according to claim 1, **characterized in that** the ceiling portion (18) is provided with a ceiling portion side operation switch portion (39) for moving the ceiling portion (18) upward and downward, which is separate from the landing hall side operation switch portion (37).
4. An elevator apparatus according to claim 3, **characterized in that** a wire winding apparatus (43) is provided and the length of a portion of an operation wiring (40), which is connected to the ceiling portion

side operation switch portion (39), between the ceiling portion side operation switch (39) and the wire winding apparatus (43) is adjusted according to upward and downward movement of the ceiling portion (18) by the wire winding apparatus (43) winding the operation wiring (40).

5. An elevator apparatus according to claim 1, **characterized in that** a wire winding apparatus (43) is provided and electric device (41) is supported by the ceiling portion (18), and wherein the length of a portion of an electric wiring (42), which is connected to the electric device (41), between the electric device (41) and the wire winding apparatus (43) is adjusted by the wire winding apparatus (41) winding the electric wiring (42).

### Patentansprüche

1. Aufzugvorrichtung mit einer Kabine (16), die innerhalb eines Aufzugschachts (1) hoch und runter gefahren wird, bei der die Kabine (16) einen Kabinenhauptkörper (17), der mit einem Kabineneingang (17a) versehen ist, und einen Deckenabschnitt (18) aufweist, der in einem oberen Endabschnitt des Kabinenhauptkörpers (17) vorgesehen ist, wobei der Deckenabschnitt (18) nach oben und nach unten zwischen einer normalen Betriebsposition, die an dem oberen Endabschnitt des Kabinenhauptkörpers (17) angeordnet ist, und einer Einstiegs-/Ausstiegsposition beweglich ist, die tiefer als die normale Betriebsposition innerhalb des Kabinenhauptkörpers (17) angeordnet ist, und die zum Ermöglichen einer Bewegung eines Beschäftigten von einer Zugangshalle (32) durch den Eingang und auf den Deckenabschnitt (18) vorgesehen ist, **dadurch gekennzeichnet, dass** die Zugangshalle (32) mit einem zugangshallenseitigen Schalterabschnitt (37) zum Bewegen des Deckenabschnitts (18) nach oben und nach unten vorgesehen ist.
2. Aufzugvorrichtung nach Anspruch 1, **dadurch gekennzeichnet, dass** die Zugangshalle (32) ferner mit einem Zugangshallenbedienfeld (33) mit einem Zugangshallenrufknopf (36) versehen ist, und bei welcher der zugangshallenseitige Bedienschalterabschnitt (37) innerhalb des Bedienfelds (33) versehen ist.
3. Aufzugvorrichtung nach Anspruch 1, **dadurch gekennzeichnet, dass** der Deckenabschnitt (18) mit einem deckenabschnittseitigen Bedienschalterabschnitt (39) zum Bewegen des Deckenabschnitts (18) nach oben und nach unten versehen ist, der von dem zugangshallenseitigen Bedienschalterabschnitt (37) getrennt ist.

4. Aufzugvorrichtung nach Anspruch 3, **dadurch gekennzeichnet, dass** eine Drahtaufwickelvorrichtung (43) vorgesehen ist und dass die Länge eines Abschnitts einer Bedienverdrahtung (40), die mit dem deckenabschnittseitigen Bedienschalterabschnitt (39) verbunden ist, zwischen dem deckenabschnittseitigen Bedienschalter (39) und der Drahtaufwickelvorrichtung (43) gemäß einer nach oben und nach unten Bewegung des Deckenabschnitts (18) durch die Drahtaufwickelvorrichtung (43), welche die Bedienverdrahtung (40) aufwickelt, eingestellt wird.
5. Aufzugvorrichtung nach Anspruch 1, **dadurch gekennzeichnet, dass** eine Drahtaufwickelvorrichtung (43) vorgesehen ist und dass eine elektrische Einrichtung (41) durch den Deckenabschnitt (18) abgestützt wird, und bei welcher die Länge eines Abschnitts einer elektrischen Verdrahtung (42), die mit der elektrischen Einrichtung (41) verbunden ist, zwischen der elektrischen Einrichtung (41) und der Drahtaufwickelvorrichtung (43) **dadurch** eingestellt wird, dass die Drahtaufwickelvorrichtung (41) die elektrische Verdrahtung (42) aufwickelt.

### Revendications

1. Ascenseur comprenant une cabine (16) qui est élevée et descendue à l'intérieur d'un puits (1), la cabine (16) ayant un corps principal de cabine (17) muni d'une entrée de cabine (17a), et d'une portion formant plafond (18), qui est ménagée dans une portion supérieure terminale du corps principal de la cabine (17), dans lequel :  
  
la portion formant plafond (18) est mobile vers le haut et vers le bas entre une position de fonctionnement normal qui est située au niveau de la portion supérieure terminale du corps principal de la cabine (17), et une position de retour/de départ qui est située plus bas que la position de fonctionnement normal à l'intérieur du corps principal de la cabine (17), et prévue pour permettre le mouvement d'un ouvrier à partir d'un hall de réception (32), en passant par l'entrée, et sur la portion formant plafond (18) ; dans lequel le hall de réception (32) est pourvu d'une portion formant commutateur latéral de commande du hall de réception (37) pour déplacer la portion formant plafond (18) vers le haut et vers le bas.
2. Ascenseur selon la revendication 1, **caractérisé en ce que** le hall de réception (32) est en outre muni d'un panneau de fonctionnement du hall de réception (33) ayant un bouton d'appel du hall de réception (36), et dans lequel la portion formant commutateur

latéral de fonctionnement du hall de réception (37) est logée à l'intérieur du panneau de fonctionnement (33).

3. Ascenseur selon la revendication 1, **caractérisé en ce que** la portion formant plafond (18) est équipée d'une portion formant commutateur latéral de fonctionnement de la portion formant plafond (39) pour déplacer la portion formant plafond (18) vers le haut et vers le bas, qui est séparée de la portion formant commutateur latéral de fonctionnement du hall de réception (37). 5  
10
4. Ascenseur selon la revendication 3, **caractérisé en ce qu'**un appareil d'enroulement de câble (43) est fourni et que la longueur d'une portion d'un câblage de fonctionnement (40), qui est reliée à la portion formant commutateur latéral de fonctionnement de la portion formant plafond (39), entre le commutateur latéral de fonctionnement de la portion formant plafond (39) et l'appareil d'enroulement de câble (43) est ajustée selon le mouvement vers le haut et vers le bas de la portion formant plafond (18) par l'appareil d'enroulement de câble (43) enroulant le câblage de fonctionnement (40). 15  
20  
25
5. Ascenseur selon la revendication 1, **caractérisé en ce qu'**un appareil d'enroulement de câble (43) est fourni et qu'un dispositif électrique (41) est supporté par la portion formant plafond (18), et dans lequel la longueur d'une portion d'un câblage électrique (42), qui est reliée au dispositif électrique (41), entre le dispositif électrique (41) et l'appareil d'enroulement de câble (43) est ajustée par l'appareil d'enroulement de câble (41) enroulant le câblage électrique (42). 30  
35

40

45

50

55

FIG. 1

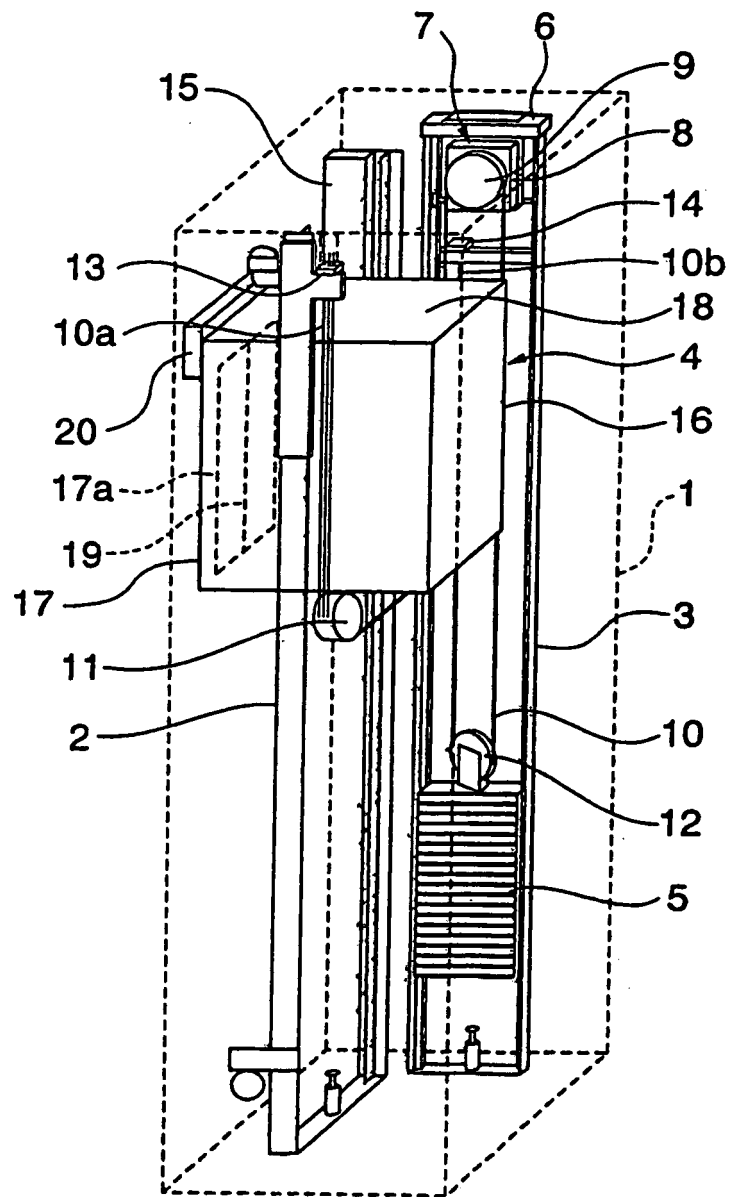

FIG. 2

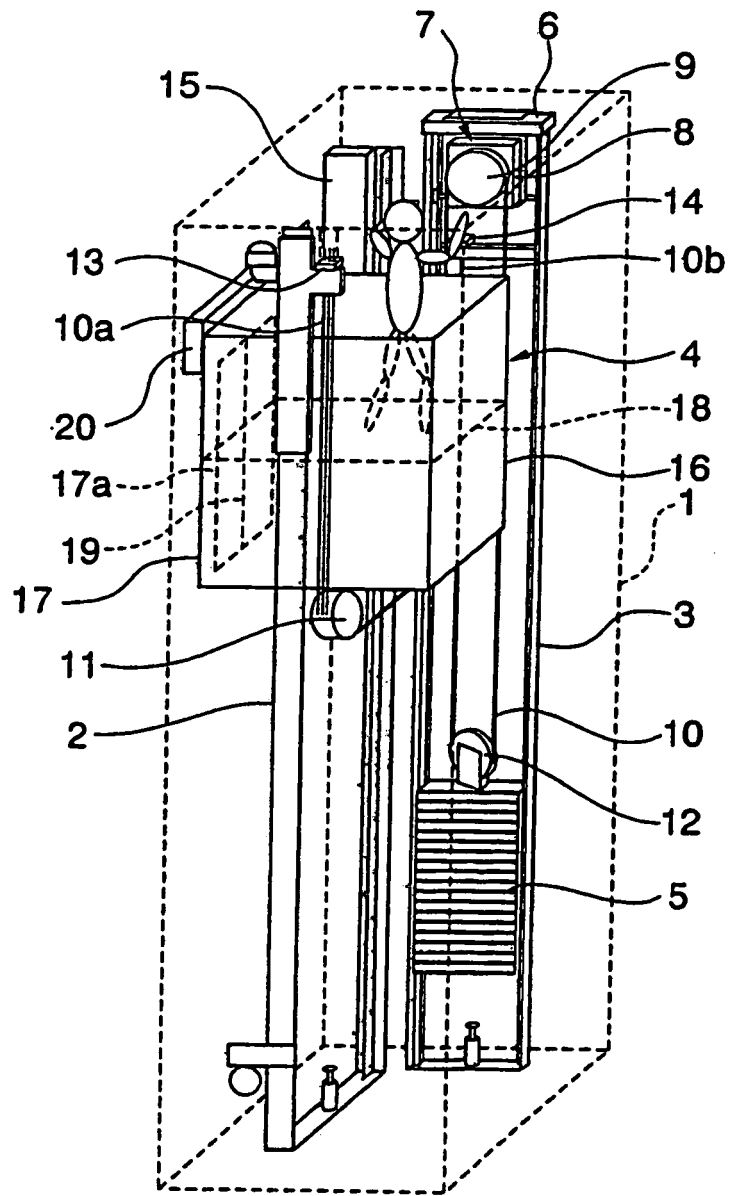

FIG. 3

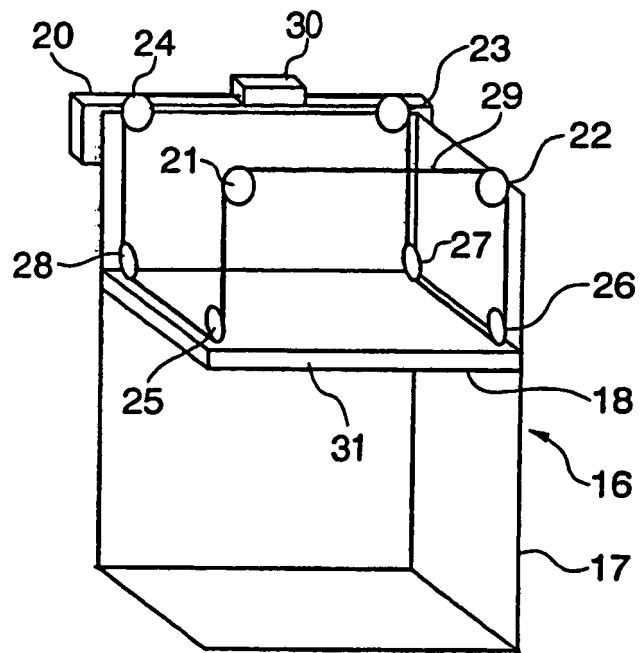



FIG. 5

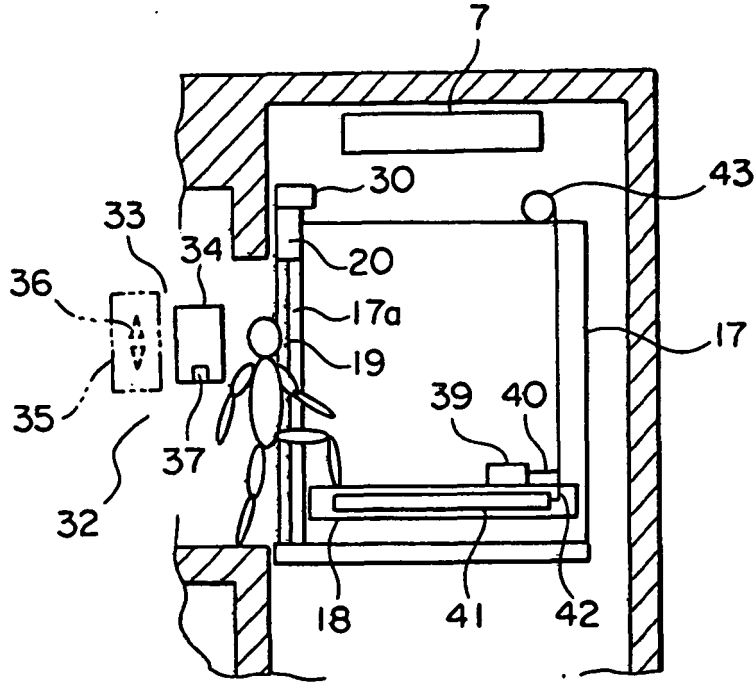
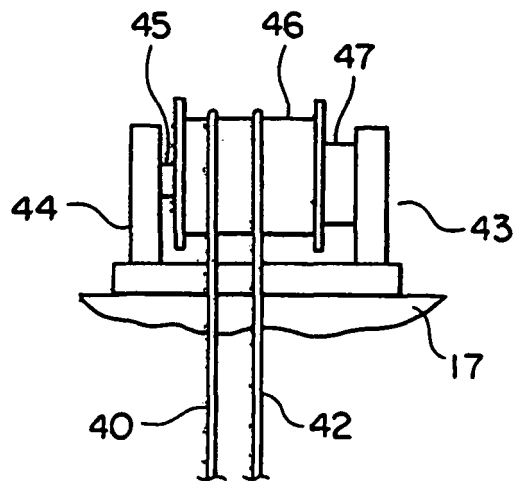

FIG. 6



**REFERENCES CITED IN THE DESCRIPTION**

*This list of references cited by the applicant is for the reader's convenience only. It does not form part of the European patent document. Even though great care has been taken in compiling the references, errors or omissions cannot be excluded and the EPO disclaims all liability in this regard.*

**Patent documents cited in the description**

- JP 09263372 A [0002]
- JP 2001106459 A [0003]