



(11) **EP 1 587 379 B9**

(12) **CORRECTED EUROPEAN PATENT SPECIFICATION**

- (15) Correction information:
Corrected version no 1 (W1 B1)
Corrections, see
Description Paragraph(s) 2, 16
Claims EN 1, 6, 13
- (51) Int Cl.:
A23N 7/00 *(2006.01)* **F16K 24/00** *(2006.01)*
- (86) International application number:
PCT/IE2004/000003
- (87) International publication number:
WO 2004/062392 (29.07.2004 Gazette 2004/31)
- (48) Corrigendum issued on:
15.02.2017 Bulletin 2017/07
- (45) Date of publication and mention of the grant of the patent:
13.04.2011 Bulletin 2011/15
- (21) Application number: **04701424.6**
- (22) Date of filing: **12.01.2004**

(54) **PRESSURE RELEASE ARRANGEMENTS, IN PARTICULAR FOR PRODUCT PROCESSING SYSTEM**

DRUCKENTLASTUNGSANORDNUNGEN, INSBESONDERE FÜR
PRODUKTVERARBEITUNGSSYSTEM

AGENCEMENTS DE DECHARGE DE PRESSION, EN PARTICULIER POUR SYSTEME DE
TRAITEMENT DE PRODUITS

-
- | | |
|---|---|
| <p>(84) Designated Contracting States:
AT BE BG CH CY CZ DE DK EE ES FI FR GB GR HU IE IT LI LU MC NL PT RO SE SI SK TR</p> <p>(30) Priority: 13.01.2003 IE 20030015</p> <p>(43) Date of publication of application:
26.10.2005 Bulletin 2005/43</p> <p>(73) Proprietor: OSENEY LIMITED
Dublin 24 (IE)</p> | <p>(72) Inventor: BRODERICK, Michael
Co. Carlow (IE)</p> <p>(74) Representative: Walsh, Michael Joseph et al
Tomkins & Co.
5, Dartmouth Road
Dublin 6 (IE)</p> <p>(56) References cited:
EP-A- 0 431 702 WO-A-01/93704
US-A- 3 164 181 US-A- 3 811 279
US-A- 4 064 794 US-A- 4 589 627</p> |
|---|---|

EP 1 587 379 B9

Description**Field of the Invention****Background to the Invention**

[0001] The field of the invention relates to the release of pressure, e.g. steam pressure, especially product processing systems, and in particular for systems for the processing or treatment of food products. More specifically, the field of the invention relates to steam peeling, especially steam peeling systems, more particularly steam peeling apparatus including a steam peeler pressure vessel. The present invention is specifically directed to pressure relief or reduction arrangements for steam exhaust from a steam peeler pressure vessel, as well as arrangements for environmental treatment of steam exhaust or discharge from a steam peeler pressure vessel.

Description of the prior art

[0002] Reference is made to Applicant's International Patent Application No. PCT/IE 01/00076, Publication No. WO/A/01/93704, in which there is described a pressure vessel for steam treatment of product to be peeled in a steam peeling system. The rotatable pressure vessel has substantially the shape of a sphere with opposed flattened side surfaces. Internal lifting features enable entraining and raising of product relative to the axis of the rotation of the pressure vessel during such rotation. Internal regions closed off against ingress of steam during product treatment define steam savers. A product treatment system incorporating the rotatable pressure vessel may also include a batcher for delivery of product to be peeled. There may be provision for accelerated pressure drop on completion of a peeling operation, as well as arrangements for minimising release of entrained solid matter and/or odours in exhaust steam. Control features of the system enable unproductive displacement of the pressure vessel to be minimised.

[0003] US 3,811,279 disclose a shut-off valve operated via a servo-motor under the influence of the working medium in the circuit. One side of the servo-piston is connected to a first pressure point in the circuit while the opposite side is connected to a second pressure point in the circuit of different pressure, to open and close the shut off valve.

[0004] In a known valve arrangement for controlling release of steam from a peeling pressure vessel on completion of a peeling operation, a balanced pressure valve is held closed against the steam pressure in a non-rotatable pressure vessel during the peeling operation. Discharge of the steam pressure is enabled by release of the biasing valve-closing force, so that the valve opening action is assisted by the force of the steam exiting from the pressure vessel.

Brief Summary of the Invention

[0005] It is an object of the invention to provide a pressure release arrangement, especially for a product processing system. It is a particular object of the invention to provide further improved arrangements for accelerating pressure relief in a steam peeling system. Yet another objective of the invention relates to effecting improvements in the manner of exhausting steam to atmosphere in a steam peeling system.

[0006] According to a first aspect, the invention is directed to a self-sealing pressure release apparatus comprising a pressure vessel and a valve for enabling release of pressurized steam from a pressure vessel, the valve comprising a displaceable closure member which, in its closed disposition, is maintained in said closed disposition by exposure to the pressure of the steam within the pressure vessel.

[0007] The closure member may be displaceable between said closed disposition and an open disposition by a double-acting actuator. Said double-acting actuator may comprise an air-driven piston/cylinder device. The closure member may be mounted at one axial end of a spindle extending between the closure member and said actuator. The valve body suitably comprises gland packing through which said spindle extends.

[0008] In a preferred embodiment of the valve of the invention, the valve member is mounted for substantially metal-to-metal contact with a valve seat portion, without interposition of any sealing element. The closure member may have a face portion which is interchangeably secured to the remainder of the closure member. The valve may also comprise a replaceable seat portion for engagement by the face portion of the closure member, the seat portion being likewise interchangeably secured to a valve body portion in the seat region.

[0009] The closure member is suitably mounted for substantially vertical displacement between said closed disposition and an open disposition thereof. In a particular construction of the valve according to the invention, the nominal flange size of the valve body at the steam exit side is substantially greater than the nominal flange size of the valve body at the steam entry side. Thus there is a commensurate increase in valve body size between the steam entry and exit locations with a corresponding enlargement of steam flow area through the valve, thereby providing an enhanced expansion effect for steam passing through the valve.

[0010] In a second aspect, the invention is directed to a product treatment system comprising a self-sealing pressure release apparatus with a valve as specified above, wherein the valve is mounted for release of pressurized steam into an expansion region substantially at the point of entry of steam into said expansion region.

[0011] In a further aspect, the invention may encompass a product treatment system comprising a pressure vessel, an expansion region for receiving pressurized steam discharged from the pressure vessel at the end of

a steam treatment phase of said product treatment, and a solids trap, said solids trap being in communication with the expansion region to receive steam at a substantially reduced pressure as compared with the steam pressure on initial entry into the expansion region, along with any entrained solid matter.

[0012] The product treatment system according to this further aspect may also specifically comprise a valve according to the first aspect of the invention for enabling release of pressurised steam from said pressure vessel into said expansion region.

[0013] In the product treatment system according to the invention, said solids trap suitably acts in a cyclonic manner. The product treatment system may further comprise an exhaust stack communicating between said solids trap and atmosphere, said stack including noise reduction means. The noise reduction means may be defined by a stack region of enlarged cross-section transverse to the direction of exhaust flow, said enlarged cross-sectional region comprising a plurality of spaced-apart perforated plates each disposed transversely to said direction of exhaust flow.

[0014] In any product treatment system according to the invention, said pressure vessel for product treatment may be rotatable, but the features of the invention, and in particular the valve according to the first aspect of the invention, are also applicable to non-rotatable or static pressure vessels, and also to pressure vessels for situations other than product treatment, where expedited but controlled release of pressure is required.

[0015] The product treatment system and pressure release apparatus of the invention are however especially suited to product treatments such as steam peeling.

Brief Description of the Drawings

[0016] The invention will now be described with reference to the accompanying drawings, of which Figures 1 to 4 and 8 correspond to Figures 7 to 9, 15 and 23 respectively of WO-A-01/93704. Figure 5 illustrates a prior art pressure release valve, while Figures 6 and 7 relate to an improved pressure release valve according to the invention. Figures 9 and 10 relate to arrangements for and improvements in trapping or entraining solids and reducing odour in exhaust emissions.

[0017] In detail:

Figure 1 is a side view of the rotatable steam peeling vessel and associated features of WO-A-01/93704,

Figure 2 is an end view from the right hand side of the arrangement of Figure 1,

Figure 3 is a top or plan view of the arrangement according to Figures 1 and 2,

Figure 4 is an end view of the rotatable steam peeling pressure vessel of WO-A-01/93704, showing rotary

drive and steam feed and exhaust arrangements,

Figure 5 is a diagrammatic cross-sectional view of a known balanced pressure steam release valve arrangement for a steam peeling pressure vessel,

Figure 6 is a diagrammatic cross-sectional view of the improved pressure release valve according to the present invention,

Figure 7 is a detailed cross-sectional representation of the valve element and seat region of the valve unit of Figure 6, with the valve element in the open disposition, shown in solid outline, and indicated in ghost in the closed disposition, and

Figure 8 shows an arrangement for solids entrainment in the exhaust features of the system of WO-A-01/93704.

Detailed Description of the Drawings

[0018] Figures 1, 2 and 3 show the steam peeling system of WO-A-01/93704. As shown in the side view of Figure 1, a steam peeling vessel 1 is mounted for rotation about an axis 7 which extends substantially horizontally and perpendicular to the plane of the paper. The pressure vessel 1 is supported for rotation on a structure also providing operator access to the system, whenever required. Infeed to the pressure vessel 1 is provided by a conveyor belt 26 to a rotary batching unit 2, by which product is transferred from the infeed belt 26 to the pressure vessel 1 in measured quantities. The representation of a human figure 27 in Figures 1 and 2 is intended to indicate the scale of the system in this exemplary embodiment.

[0019] Figure 2 shows the relative dispositions of the batching unit 2 and the pressure vessel 1, together with the relationship between the pressure vessel 1 and an expansion chamber or vessel 21 which is located to the rear of and below the pressure vessel 1 in terms of Figure 1. As indicated in Figures 2 and 3, a large diameter stack 28 extends from the expansion chamber to a discharge location (not shown in these drawings) for waste or exhaust steam. The compact arrangement of the various units of the system may be noted, the assembled system defining an especially cohesive package occupying a reduced spatial volume as compared with prior art arrangements.

[0020] The top view of Figure 3 shows the relative dispositions of these various features. In particular, as also shown in Figure 2, the locations of bearings 29,31 for the rotary pressure vessel 1 and also the dispositions of a combined unitary steam admission and discharge line 14 between vessel 1 and expansion chamber 21 are particularly apparent. Figures 2 and 3 also show drive motor and drive gear arrangements 32 and 33 respectively for vessel 1 and batching unit 2 respectively.

[0021] Figure 4 shows the rotating mounting and steam

discharge arrangements for the pressure vessel 1. On the right hand side of the pressure vessel 1, drive 33 is effected at a right-hand bearing mounting 45 (Figures 2 and 3) as shown in the drawing. On the left-hand side of the drawing, steam entry and exit is effected through a left-hand bearing mounting 44 and bearing 29 (Figures 2 and 3). Communication between the interior of the pressure vessel 1 and the single combined steam charging and discharge line 14 is effected through a rotary gland 56 with suitable packing. Thus steam admission and steam discharge takes place through a single steam port. There is only one steam port in the pressure vessel of the system, and this port serves alternately as an inlet port and an exhaust port. Steam is fed into the pressure vessel 1 through a charging line, not shown in the drawing, which communicates with line 14 by way of a suitable valve arrangement 5. Beyond the charging connection 5, in the direction away from the pressure vessel, the steam passage 14 from the pressure vessel 1 terminates at an expansion valve 57, which is mounted directly at and suitably on top of the expansion chamber 21 and defines a steam pressure release means of the system. In a specific construction for a rotatable steam peeling vessel, the valve 57 geometry provides for an inlet flange nominal diameter of substantially 254 mm (10 inches) an outlet flange nominal diameter of substantially 305 mm (12 inches). The size of the valve body is increased progressively between the entry and exit flanges to match this change (increase) in flange size as between the steam entry and exit locations, so that expansion of the steam conducted through valve 57 takes place in part through and within the actual body of valve 57. The increase in nominal flow area from valve inlet to valve outlet is thus of the order of 40%. The arrangement provides a spatial saving and may also be associated with a reduction in noise and flow turbulence at the point of entry into the expansion chamber 21, as well as a reduction in the number of components in the system and less back pressure. Valve 57 is suitably motor driven 58.

[0022] The 254 mm (10 inch) inlet flange diameter to the expansion valve 57 together with the provision of a comparable diameter and exhaust flow area at the flange of the single exhaust port 46 of vessel represents a very substantial increase in the diameter and area of the steam exhaust port or passage from the vessel 1 as compared with the maximum values hitherto in general use for rotatable steam peelers of comparable capacity. Specific dimensional ratios between vessel 1 volume in litres and exhaust port area are quoted in WO-A-01/93704.

[0023] The expansion valve 57 is exposed to pressurised steam during peeling and opens directly into the expansion vessel 21 at the appropriate time. The use of as large an expansion chamber 21 as possible means that discharge directly to atmosphere is to a significant degree simulated. Environmental regulations generally prohibit or exclude the possibility of direct discharge to atmosphere. For this reason, it is necessary to interpose an expansion chamber 21. Nonetheless the desirability

remains of achieving the maximum possible rate of pressure drop into the expansion chamber 21.

[0024] As shown schematically in Figure 4, the expansion valve 57 is an elbow valve with the internal diameter of the flow passage increasing substantially in proportion to the change from a 254 mm (10 inch) nominal flange diameter at the input side to a 305 mm (12 inch) nominal flange diameter at the output or steam discharge side of the valve 57 adjoining the expansion or blowdown chamber 21. Proceeding along the steam line 14 from the 254 mm (10 inch) nominal flange size input side of the valve in the direction of the pressure vessel 1, there are provided in sequence, from the elbow valve 57 end, the steam admission control valve 5, the rotating steam gland 56 with balancing features (not shown), and a pipe section 14, which is of substantially 254 mm (10 inches) diameter in a specific embodiment and passes through the main bearing 29 (Figures 2 and 3), this large diameter pipe section 14 providing for both steam-in and exhaust.

[0025] There is thus substantially instantaneous reduction in pressure in the steam peeler vessel 1 when exhaust takes place. By substantially instantaneous is meant a pressure drop taking place within a time period which is typically less than 1 second. By mounting the exhaust valve 57 substantially directly on or at the decompression or expansion vessel 21, the invention provides for substantial maximisation of the possible or available pressure drop. The exhaust vessel 21 and expansion valve 57 are accordingly effectively combined, for optimisation of the pressure drop. There is no lengthy separate duct communicating between expansion valve 57 and chamber 21. There is therefore effectively instant exhaust via the exhaust valve 57 and the very short steam exhaust path or line 14 from the peeling vessel 1 to the expansion vessel or chamber 21.

[0026] Figure 5 illustrates a prior art pressure release valve 11 for a non-rotatable steam peeler. The valve body 12 is again an elbow type structure, but one having steam entry 15 and exit 16 openings of the same nominal flange size and therefore, also substantially the same port area or flow diameter at both steam entry and at steam exit. There is no dimensional change in the valve body 12 as between the entry 15 and exit 16 flange regions. A valve closure element 17 is axially displaceable within the valve body 12 by means of a elongate valve spindle 18 which is actuated or driven between its closed and open dispositions by means of an air actuator or motor 19. When the static steam peeling pressure vessel is charged with steam, the valve element 17 is required to be held closed against the steam pressure at the entry port 15. A sealing member 25, e.g. of O-ring type configuration formed from a synthetic heat-resistant composition, is provided between valve element 17 and the valve seat 13 for element 17. To maintain the valve in the closed condition, a balanced pressure construction is provided, with the valve spindle 18 carrying, remote from the valve closure element 17, a piston 35 which is displaceable within and cooperates with a cylinder portion 36 of the valve body 12

to define a spatial region which is charged with steam from the pressure vessel via a central elongate bore 37 within the valve spindle 18. Thus in the closed condition of the valve 11, the steam pressure within the pressure vessel is also active behind the valve piston 35, to define a balanced pressure arrangement. The valve 11 may be held closed against the steam pressure by the balanced pressure piston 35 being dimensioned such that it exerts sufficient closing force on the valve element 17. This is achieved by piston 35 being greater in diameter than the nominal area of element 17. With this arrangement, the steam pressure acting on piston 35 must be released in order to open valve 11 for steam exhaust.

[0027] In an alternative construction, there may be substantially exact balance between the closing force exerted by piston 35 and the opening pressure prevailing on the element 17. The valve can then be held closed by the air actuator 19. While the biasing pressure required of the air motor 19 to hold the valve 11 closed is modest, the air motor 19 is nonetheless required in this arrangement to be continually active to ensure that the valve 11 remains closed against the steam pressure. Despite the balanced pressure structure, reverse action of the air motor 19 is also required in order to actuate opening of the valve 11 for release of steam from the pressure vessel, along with simultaneous or prior release of the steam pressure on piston 35.

[0028] The arrangement is effective but suffers from a number of disadvantages, in particular relating to the necessity for regular maintenance. Preservation of appropriate sealing (seal 25) between the valve elements 17 and the valve seat requires regular maintenance attention. If the air motor 19 is continually active, it is particularly subject to wear and tear, while the presence, within the valve body 12, of a balanced pressure cylinder 36, piston 35 and piston seal (reference 38), again represents a portion of the system requiring scheduled maintenance attention.

[0029] Figure 6 shows an improved pressure release valve 61 provided by the present invention. The valve of Figure 6 is particularly suitable for a rotatable vessel such as that of Figures 1 to 4, but is not limited to rotating peelers. It is also applicable to static peelers, and to static and displaceable steam pressure vessels in other product treatment systems, as well as being suitable for use in substantially any circumstances where a rapid reduction in steam pressure (viz., substantial blowdown) is needed. The direction of flow through the valve 61 is reversed as compared with the prior art valve 11. Steam enters through a 254 mm (10 inch) input flange 65 and exits through the larger 305 mm (12 inch) flange discharge opening 66. The dimensions quoted correspond to nominal flange sizes for a particular embodiment suitable for rotary steam peeling. In other embodiments, different dimensions may apply with appropriate scaling up or down of the dimensions of the valve body to correspond to the mounting requirements. As compared with the prior art, the valve element 67 closes against the valve

exit opening, which defines the valve seat 63. Thus in the charged condition of the steam peeler, the steam pressure is active to hold the valve element 67 closed. A particularly simple valve construction is thereby facilitated, in which a valve spindle 68 which does not require any internal steam passages links the valve closure element 67 directly to the drive piston 71 of an air motor or actuator 69. The air motor 69 is only required to be active to effect the valve opening operation. The sole other component of the valve 61 system subject to relative movement and potential wear is the sealing gland 72 through which the valve spindle 68 passes where it leaves the valve body 62 and extends to the air motor 69.

[0030] Thus the valve 61 of the invention is self-sealing during pressurisation and is held closed by the steam pressure. Metal-to-metal contact is provided between the valve seat 63 and the valve disk 67. This arrangement provides a self-cleaning effect at the valve seat 63. The air piston 71 is active for generally approximately 0.25 seconds to effect the valve opening action. While the valve element 67 requires to be displaced against the steam pressure, as compared with the pressure-assisted opening of the prior art, rapid movement of the element 67 against the pressure is readily achieved by suitable selection of the dimensions of the air motor 69, in particular piston 71 and cylinder diameter, and of the air pressures used. No difficulty has been experienced in experiments in opening the valve of the invention within the required brief time period, even against full steam pressure. Effectively the valve of the invention operates by brute force and does so in a fully successful manner.

[0031] Service experience has shown that any wear arising at the valve seat 63 is substantially uniform, this being attributed to uniform velocity of exiting steam around the full periphery of the valve element 67 during the expansion stage. This uniformity of flow also enhances the self-cleaning effect. Service experience has also shown that the gland packing 72 is almost maintenance free. In extended experimental use, no gland leakage was exhibited and only the most minimal adjustment was required. No replacement of the gland packing 72 was required over an extended period of experimental operation. The absence of gland wear is attributed to the substantially instantaneous pressure drop, which takes place in less than one second. Experimental investigations suggest that seat damage and gland damage in discharge valves for steam in which there is possible carry-over of solids are largely confined to the period when these solid residues pass through the valve. In the arrangement of the invention, such residues arrive only at the end of the discharge period when the pressure has already fallen significantly and the speed at which any residues impinge on valve surfaces and components is therefore diminished. Furthermore, the valve spindle 68 in the region which co-operates with the gland packing 72 when the valve is closed is not exposed to residue impact during the discharge period. When the valve 61 is pressurised, the valve components, including the spin-

dle 68 and the valve-inward region of the gland packing 72 are exposed only to static pressure. Also, during this stage of the operation, the steam is clean. Thus damage due to solids carry-over cannot arise during the pressurisation period.

[0032] Figure 7 shows greater detail of a particular embodiment of valve element 67 and co-operating valve seat 63. Prior art arrangements include bowl type elements, plug type elements and hemispherical closure elements. The structure shown in Figure 7 provides a generally cylindrical upper valve closure element portion 67a, below which there is provided a frustoconical portion 67b, tapering inwards towards the free end of the valve element 67, this conical section 67b being followed in the exemplary embodiment by a final terminating cylindrical guide portion 67c. During closing movement of the valve element 67, this lead or guiding portion 67c enters into the valve exit aperture and steers the valve element 67 into effective sealing engagement with the seat region 63.

[0033] In the embodiment shown, the lower end of the valve element (cone 67b and lead face 67c) is provided to be replaceable. The seat 63 is also defined by a replaceable annular ring 65, both of these interchangeable elements suitably being bolt-on fittings. Differential hardness may be provided as between these components. The seat ring 64 may for example be significantly harder than the co-operating engaging lower region 67b, 67c of the valve element 67. An exemplary material suitable for this purpose is stellite, but a diversity of alternative substances may be employed. Differential hardness means that one material will wear more quickly than the other. Thus initial edge or line contact between the frustoconical lower part 67b of the valve element 67 and an initially sharply-defined edge region or corner of the seat 63, becomes modified with ongoing wear to a more extensive surface contact. However, the nature of this wear is such that good seating characteristics of the valve 61 will be maintained throughout its life. Any progressive wear is automatically compensated for by increased travel of the valve element 67, without any specific adjustment being required.

[0034] Thus a particular point of novelty of the present invention in this specific embodiment is the use of replaceable elements for the valve trim, i.e. the combination of valve element 67 and seat 63. The demountability and ready replaceability of these parts of the pressure relief valve assembly 61 enables economy in maintenance to the extent that when limits of wear are ultimately reached, the active components of the valve 63 can be replaced without the necessity to replace either the complete valve body 62 or all of its moving parts, or to demount the valve body 62 for rectification work.

[0035] In the preferred arrangement shown in Figures 6 and 7, the valve 61 is mounted for vertical movement of the valve member. This provides for self alignment in the opening and closing action, particularly the latter. Minimal air pressure is required to close the valve, as little as 0.3516 kg/cm (5 PSI (pounds per square inch))

or even less, given this particular advantageous orientation of the valve member 67. For a 3:1 ratio of air valve piston 71 to valve seat 63 diameter, the opening pressure may typically be 6.3291 kg/cm - 7.0323 kg/cm (90-100PSI), this being effective to overcome the typical 21.097 kg/cm (300 PSI) steam pressure prevailing within a steam peeler in its active phase.

[0036] Thus the valve construction of the invention provides an operationally effective arrangement, which suffers only to the most minimal extent from carry-over of residues, and is proof against significant damage of any catastrophic nature even from those residues which are carried over. The valve of the invention may be applied to pressure relief in any product treatment system, whether using a static or displaceable (rotating) pressure vessel, and may be used with or without the particularly favoured arrangement described above with reference to a specific embodiment, in which there is a dimensional increase between valve entry and exit. The valve of the invention may be deployed in arrangements in which a different dimensional relationship applies between steam entry and exit. It may also be applied to controlled release of steam pressure in any context, not necessarily limited to product treatment.

[0037] Figure 8 shows a particular embodiment of the expansion chamber 21 of the system of WO-A-01/93704. Steam enters the expansion chamber 21 at valve 57 from the steam peeler pressure vessel in the manner already described and the volume of the expansion chamber 21 is sufficient for very rapid reduction of pressure as the steam discharges into it.

[0038] Condensate accumulating on floor 73 collects at sump 74. Optional baffle 75 is located between the steam entry point and the discharge duct or stack 28. Baffle 75, where provided, extends downwards at an acute angle from the roof of the chamber 21 towards the stack 28 region of the chamber 21 in the direction of the exit point where steam leaves the chamber 21 and enters the stack 28.

[0039] The discharge stack 28 does not exit directly from the expansion chamber 21 proper, but rather from a solids trap 78, defined by a hopper-type structure communicating with the expansion chamber 21 by way of a duct 79 of large dimensions. The stack 28, again of large cross-sectional area, exits from an upper region 81 of this solids trap, but has a downwardly projecting flange or extension 82 extending in part into the solids trap 78, so that steam or vapour exiting from the expansion chamber 21 is required to follow a convoluted path from the upper steam entry region 81 of the solids trap 78 initially in a downwards direction, to turn around the edge of the downwardly projecting flange or extension 82 and then discharge upwards through the stack 28.

[0040] As shown more particularly in Figure 9, the solids trap 78 functions as a cyclone, with the steam exit from chamber 21 positioned for tangential entry of the exhaust steam and entrained solids into the unit 78. The cyclonic swirling action within the trap 78 provides for

particularly effective separation of solids from entrained steam, before final discharge of vapour through the stack 28 following the downward movement of the steam flow to turn under the lower edge of extension 82, at which location the majority of any carried-over solids fall to the base of the cyclone and are accumulated for collection or discharge.

[0041] The provision of an independent solids trap 78, operating entirely independently of the expansion vessel 21, has proven particularly effective. In the primary expansion tank 21, pressure typically drops from around 20 bar at entry to 0.15 bar gauge towards the exit point, in other words slightly above atmospheric. This continuing positive pressure is sufficient to bring about effective solids removal in the second stage 78. The relatively low ongoing pressure of steam and residue reaching the separator 78 means that the solids velocity is then low enough for effective solids separation, such as by cyclonic action. Because of the relatively low velocity, but combined with adequate ongoing progressive movement, almost all solids are removed in the separator and there is minimal carry-over to the stack. Single stage pressure reduction combined with solids removal is less effective, in that the steam velocity in such a combined operation may be excessive for satisfactory removal of solids. Thus the low speed cyclone provided by the arrangement of the present invention is particularly effective in solids separation.

[0042] It is also possible for the solids removal unit 78 to be physically displaced to a location significantly removed from the location of the steam blowdown tank 21. Thus the pressure chamber 21 may be located within a factory building and the solids removal unit 78 located for example externally of the building. Duct 79 may therefore be substantially longer than the diagrammatic indication of Figure 8.

[0043] Figure 10 illustrates such a possibility. The broken line 79 indicates the possibility of spacing the solids removal operation from the primary expansion tank. While Figure 10 is primarily diagrammatic, it also shows an arrangement of tank 21 in which there is no baffle. Thus the baffle 75 represents merely an optional feature and not an essential integer of the expansion unit.

[0044] In a further aspect of the invention, Figure 10 also illustrates a noise suppression chamber 91 which may be provided in the stack 28. For this purpose, the stack includes the noise suppression chamber 91, which is of enlarged diameter relative to the gas flow direction and has a cross-sectional area greater than that of the remainder of the stack 28. A spaced-apart series of perforated plates 92 is provided within this widened portion of the exhaust stack 28, suitably vertically disposed one above the other and transverse to the air flow direction. The arrangement produces effective noise suppression in an installation embodying the features of the invention.

Claims

1. A self-sealing pressure release apparatus comprising: a pressure vessel (1); a valve (61) for enabling release of pressurized steam from the pressure vessel (1), the valve (61) comprising a displaceable closure member (67) which, in its closed disposition, is maintained in said closed disposition only by exposure to the pressure of the steam within the pressure vessel (1); and a double acting actuator (69) for displacing the closure member (67) from said closed disposition to an open disposition against the pressure of the steam within the pressure vessel (1) for said release of steam from the pressure vessel (1).
2. A self-sealing pressure release apparatus according to Claim 1, wherein said double-acting actuator (69) comprises an air-driven piston/cylinder device.
3. A self-sealing pressure release apparatus according to Claim 1 or Claim 2, wherein the closure member (67) is mounted at one axial end of a spindle (68) extending between the closure member (67) and said actuator (69).
4. A self-sealing pressure release apparatus according to any preceding claim, wherein the closure member (67) is mounted for substantially metal-to-metal contact with a valve seat portion (63), without interposition of any sealing element.
5. A self-sealing pressure release apparatus according to any preceding claim, wherein the closure member (67) has a face portion (67b, 67c) which is interchangeably secured to the remainder (67a) of the closure member (67).
6. A self-sealing pressure release apparatus according to any preceding claim, comprising a seat portion (64) for engagement by a face portion (67b, 67c) of the closure member (67), the seat portion (64) being interchangeably secured to a valve body portion (62) in the seat region.
7. A self-sealing pressure release apparatus according to any preceding claim, wherein the closure member (67) is mounted for substantially vertical displacement between said closed disposition and an open disposition of the valve (61).
8. A self-sealing pressure release apparatus according to any preceding claim, wherein the nominal flange size of the valve body at the steam exit side (66) is substantially greater than the nominal flange size of the valve body at the steam entry side (65).
9. A product treatment system comprising a self-sealing pressure release apparatus according to any pre-

ceding claim, wherein the valve (61) is mounted for release of pressurized steam into an expansion region (21) substantially at the point of entry of steam into said expansion region (21).

10. A product treatment system comprising a pressure vessel (1) and a solids trap (78), said solids trap (78) being in communication with an expansion region (21) to receive steam from the expansion region (21) at a substantially reduced pressure as compared with the steam pressure on initial entry into the expansion region (21), along with any entrained solid matter, **characterised in that** the expansion region (21) is adapted for receiving pressurised steam discharged from the pressure vessel (1) at the end of a steam treatment phase of said product treatment via a self-sealing pressure release apparatus according to any of Claims 1 to 9.
11. A product treatment system according to Claim 10, wherein said solids trap (78) acts in a cyclonic manner.
12. A product treatment system according to Claim 10 or Claim 11, comprising an exhaust stack (28) communicating between said solids trap (78) and atmosphere, said stack (28) including noise reduction means (91, 92).
13. A product treatment system according to Claim 12, wherein said noise reduction means (91, 92) is defined by a stack region of enlarged cross-section (91) transverse to the direction of exhaust flow, said enlarged cross-sectional region (91) comprising a plurality of spaced-apart perforated plates (92) each disposed transversely to said direction of exhaust flow.
14. A product treatment system according to any of Claims 10 to 13, wherein said pressure vessel (1) is rotatable, and said product treatment comprises steam peeling.

Patentansprüche

1. Selbstdichtende Druckentlastungsvorrichtung mit: einem Druckbehälter (1); einem Ventil (61) zur Ermöglichung des Auslassens von Druckdampf aus dem Druckbehälter (1), wobei das Ventil (61) ein bewegbares Schließteil (67) aufweist, das in seiner Schließposition nur durch die Einwirkung des Drucks des in dem Druckbehälter (1) befindlichen Dampfs in der Schließposition gehalten wird; und einem doppeltwirkenden Betätigungsteil (69) zum Bewegen des Schließteils (67) aus der Schließposition in eine Öffnungsposition gegen den Druck des in dem Druckbehälter (1) befindlichen Dampfs, um das Auslassen von Dampf aus dem Druckbehälter (1) zu be-

wirken.

2. Selbstdichtende Druckentlastungsvorrichtung nach Anspruch 1, bei der das doppeltwirkende Betätigungsteil (69) eine luftbetriebene Kolben-Zylinder-Vorrichtung aufweist.
3. Selbstdichtende Druckentlastungsvorrichtung nach Anspruch 1 oder Anspruch 2, bei der das Schließteil (67) an einem axialen Ende einer Spindel (68) angeordnet ist, die sich zwischen dem Schließteil (67) und dem Betätigungsteil (69) erstreckt.
4. Selbstdichtende Druckentlastungsvorrichtung nach einem der vorhergehenden Ansprüche, bei der das Schließteil (67) derart angeordnet ist, dass es ohne Zwischenlage eines Dichtelements in einen im Wesentlichen von Metall zu Metall erfolgenden Kontakt mit einem Ventilsitzteil (63) treten kann.
5. Selbstdichtende Druckentlastungsvorrichtung nach einem der vorhergehenden Ansprüche, bei der das Schließteil (67) ein Stirnteil (67b, 67c) aufweist, das auswechselbar am Rest (67a) des Schließteils (67) befestigt ist.
6. Selbstdichtende Druckentlastungsvorrichtung nach einem der vorhergehenden Ansprüche, mit einem Sitzteil (64), an dem ein Stirnteil (67b, 67c) des Schließteils (67) angreifen kann, wobei das Sitzteil (64) an einem in dem Sitzbereich gelegenen Ventilkörperteil (6) auswechselbar befestigt ist.
7. Selbstdichtende Druckentlastungsvorrichtung nach einem der vorhergehenden Ansprüche, bei der das Schließteil (67) derart angeordnet ist, dass es im Wesentlichen vertikal zwischen der Schließposition und der Öffnungsposition des Ventils (61) bewegbar ist.
8. Selbstdichtende Druckentlastungsvorrichtung nach einem der vorhergehenden Ansprüche, bei der die Nenn-Flanschgröße des Ventilkörpers an der Dampfaustrittsseite (66) im Wesentlichen größer ist als die Nenn-Flanschgröße des Ventilkörpers an der Dampfeintrittsseite (65).
9. Produktbehandlungssystem mit einer selbstdichtenden Druckentlastungsvorrichtung nach einem der vorhergehenden Ansprüche, bei dem das Ventil (61) zum Auslassen von Druckdampf in einen Erweiterungsbereich (21) hinein angeordnet ist, der im Wesentlichen an dem Eintrittspunkt des Dampfs in den Erweiterungsbereich (21) erfolgt.
10. Produktbehandlungssystem mit einem Druckbehälter (1) und einem Feststoffabscheider (78), wobei der Feststoffabscheider (78) in Verbindung mit einem Erweiterungsbereich (21) steht, um Dampf von

dem Erweiterungsbereich (21) mit einem im Vergleich zu dem Dampfdruck beim Ersteintritt in den Erweiterungsbereich (21) im Wesentlichen reduzierten Druck zusammen mit sämtlichen mitgeführten Feststoffen zu empfangen, **dadurch gekennzeichnet, dass** der Erweiterungsbereich (21) in der Lage ist, Druckdampf, der am Ende einer Dampfbehandlungsphase der Produktbehandlung aus dem Druckbehälter (1) ausgegeben wird, über eine selbstdichtende Druckentlastungsvorrichtung nach einem der Ansprüche 1 bis 9 zu empfangen.

11. Produktbehandlungssystem nach Anspruch 10, bei dem der Feststoffabscheider (78) zyklisch arbeitet.
12. Produktbehandlungssystem nach Anspruch 10 oder Anspruch 11, mit einem Abgaskamin (28), der eine Verbindung zwischen dem Feststoffabscheider (78) und der Atmosphäre bildet, wobei der Kamin (28) eine Geräuschreduzierungsvorrichtung (91,92) aufweist.
13. Produktbehandlungssystem nach Anspruch 12, bei dem die Geräuschreduzierungsvorrichtung (91,92) durch einen Kaminbereich mit quer zur Abgasstromrichtung vergrößertem Querschnitt (91) definiert ist, wobei der vergrößerte Querschnittsbereich (91) mehrere voneinander beabstandete Lochplatten (92) aufweist, die jeweils quer zur Abgasstromrichtung angeordnet sind.
14. Produktbehandlungssystem nach einem der Ansprüche 10 bis 13, bei dem der Druckbehälter (1) drehbar ist und die Produktbehandlung eine Dampf-schälung aufweist.

Revendications

1. Appareil de décharge de pression auto-scellant comprenant : une cuve de pression (1) ; une soupape (61) permettant de libérer de la vapeur pressurisée depuis la cuve de pression (1), la soupape (61) comprenant un organe de fermeture (67) déplaçable qui, dans sa disposition fermée, est maintenue dans ladite position fermée uniquement par une exposition à la pression de la vapeur au sein de la cuve de pression (1) ; et un actionneur à double action (69) permettant de déplacer l'organe de fermeture (67) de ladite disposition fermée à une disposition ouverte contre la pression de la vapeur au sein de la cuve de pression (1) pour ladite décharge de vapeur depuis la cuve de pression (1).
2. Appareil de décharge de pression auto-scellant selon la revendication 1, dans lequel ledit actionneur à double action (69) comprend un dispositif de piston/cylindre entraîné par air.
3. Appareil de décharge de pression auto-scellant selon la revendication 1 ou la revendication 2, dans lequel l'organe de fermeture (67) est monté au niveau d'une extrémité axiale d'une fusée (68) s'étendant entre l'organe de fermeture (67) et ledit actionneur (69).
4. Appareil de décharge de pression auto-scellant selon l'une quelconque des revendications précédentes, dans lequel l'organe de fermeture (67) est monté pour un contact sensiblement métal à métal avec une portion de siège de soupape (63), sans interposition d'aucun élément de scellage.
5. Appareil de décharge de pression auto-scellant selon l'une quelconque des revendications précédentes, dans lequel l'organe de fermeture (67) comporte une portion de face (67b, 67c) qui est fixée de façon interchangeable au reste (67a) de l'organe de fermeture (67).
6. Appareil de décharge de pression auto-scellant selon l'une quelconque des revendications précédentes, comprenant une portion de siège (64) pour mise en prise par une portion de face (67b, 67c) de l'organe de fermeture (67), la portion de siège (64) étant fixée de façon interchangeable à une portion de corps de soupape (62) dans la région de siège.
7. Appareil de décharge de pression auto-scellant selon l'une quelconque des revendications précédentes, dans lequel l'organe de fermeture (67) est monté pour un déplacement sensiblement vertical entre ladite disposition fermée et une disposition ouverte de la soupape (61).
8. Appareil de décharge de pression auto-scellant selon l'une quelconque des revendications précédentes, dans lequel la taille de bride nominale du corps de soupape du côté sortie de vapeur (66) est sensiblement plus grande que la taille de bride nominale du corps de soupape du côté entrée de vapeur (65).
9. Système de traitement de produit comprenant un appareil de décharge de pression auto-scellant selon l'une quelconque des revendications précédentes, dans lequel la soupape (61) est montée pour décharge de la vapeur pressurisée dans une région de détente (21) sensiblement au point d'entrée de la vapeur dans ladite région de détente (21).
10. Système de traitement de produit comprenant une cuve de pression (1) et un piège à solides (78), ledit piège à solides (78) étant en communication avec une région de détente (21) pour recevoir de la vapeur de la région de détente (21) à une pression sensiblement réduite en comparaison à la pression de vapeur lors de l'entrée initiale dans la région de détente (21).

tente (21), conjointement avec toute matière solide entraînée, **caractérisé en ce que** la région de détente (21) est adaptée pour recevoir de la vapeur pressurisée évacuée de la cuve de pression (1) à l'extrémité d'une phase de traitement de vapeur du dit traitement de produit via un appareil de décharge de pression auto-scellant selon l'une quelconque des revendications 1 à 9.

5

11. Système de traitement de produit selon la revendication 10, dans lequel ledit piège à solides (78) agit de manière cyclonique.

10

12. Système de traitement de produit selon la revendication 10 ou la revendication 11, comprenant un empilement d'échappements (28) communiquant entre ledit piège à solides (78) et l'atmosphère, ledit empilement (28) comprenant un moyen de réduction de bruit (91, 92).

15

20

13. Système de traitement de produit selon la revendication 12, dans lequel ledit moyen de réduction de bruit (91, 92) est défini par une région d'empilement de section agrandie (91) transversale à la direction du flux d'échappement, ladite région de section agrandie (91) comprenant une pluralité de plaques perforées espacées (92) disposées chacune transversalement à ladite direction du flux d'échappement.

25

30

14. Système de traitement de produit selon l'une quelconque des revendications 10 à 13, dans lequel ladite cuve de pression (1) est rotative, et ledit traitement de produit comprend un pelage à la vapeur.

35

40

45

50

55

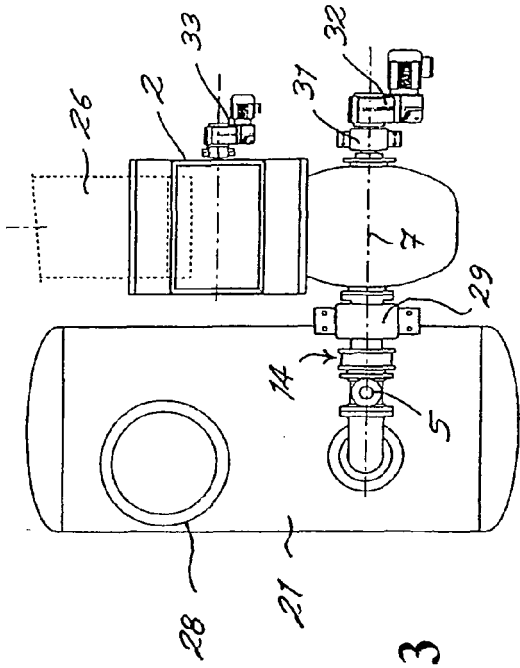

Fig. 3

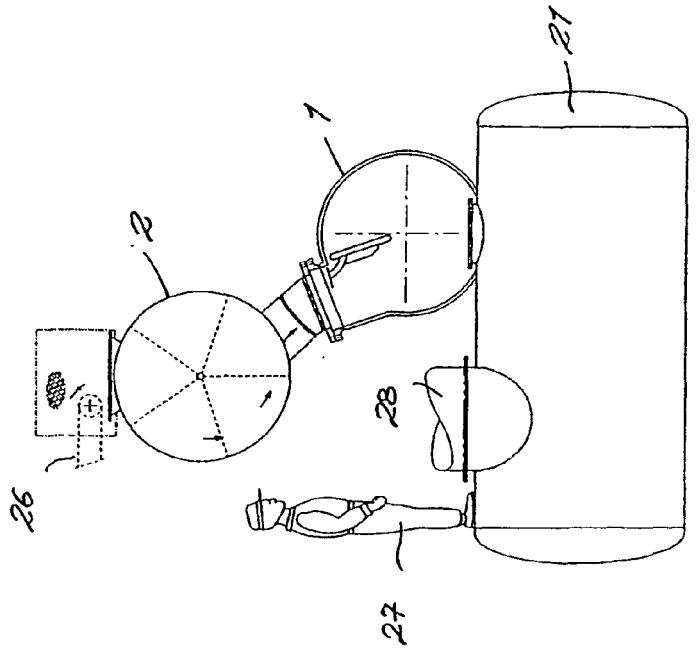

Fig. 1

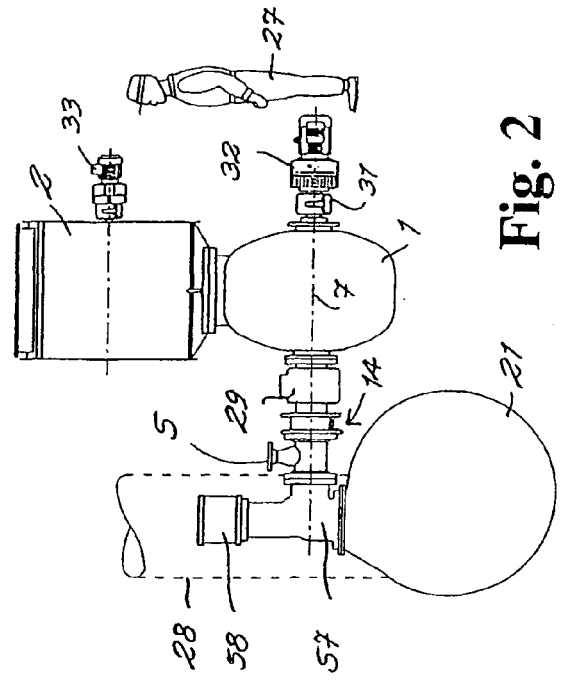

Fig. 2

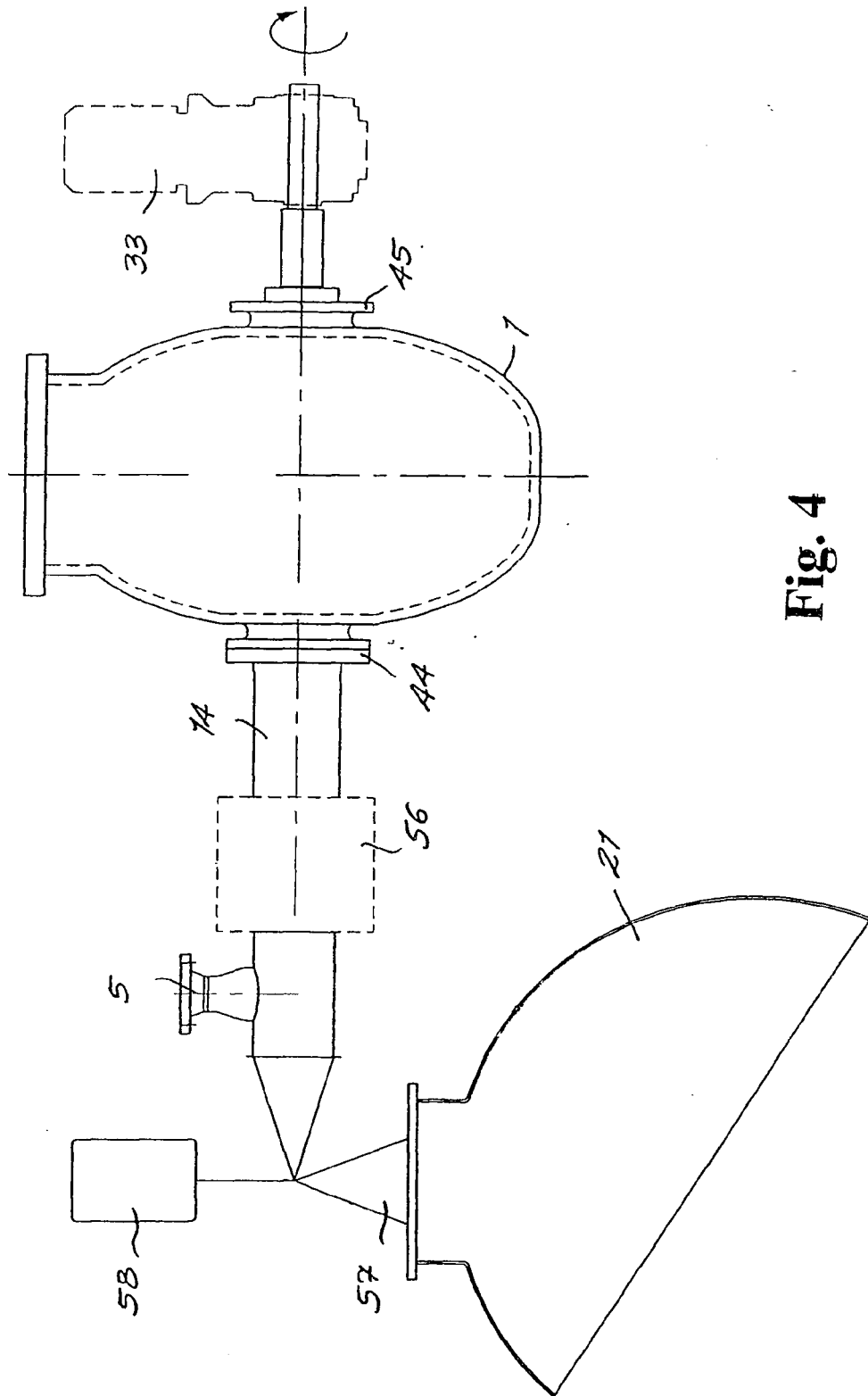

Fig. 4

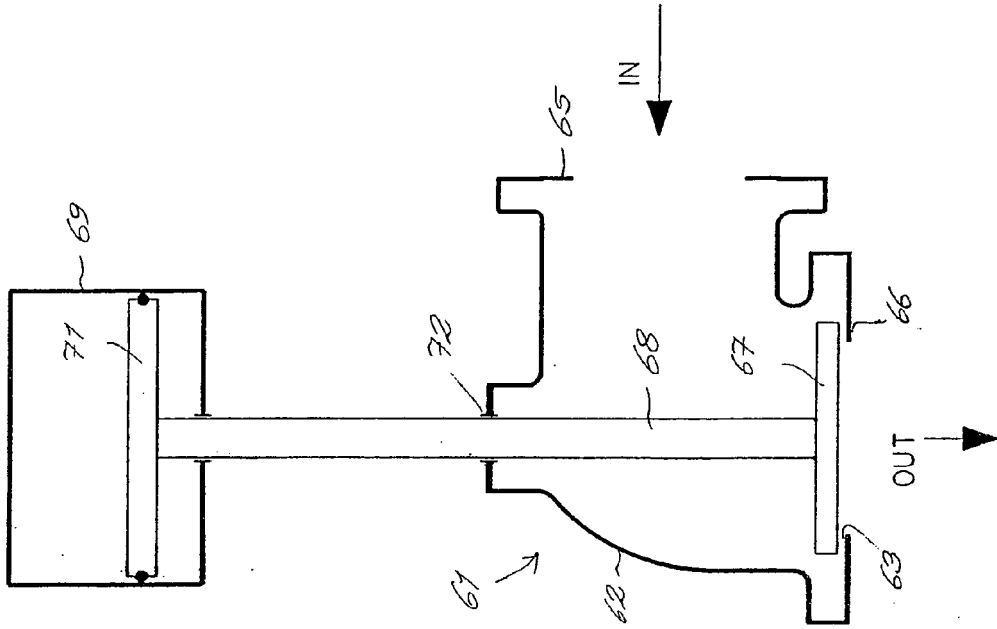

Fig. 6

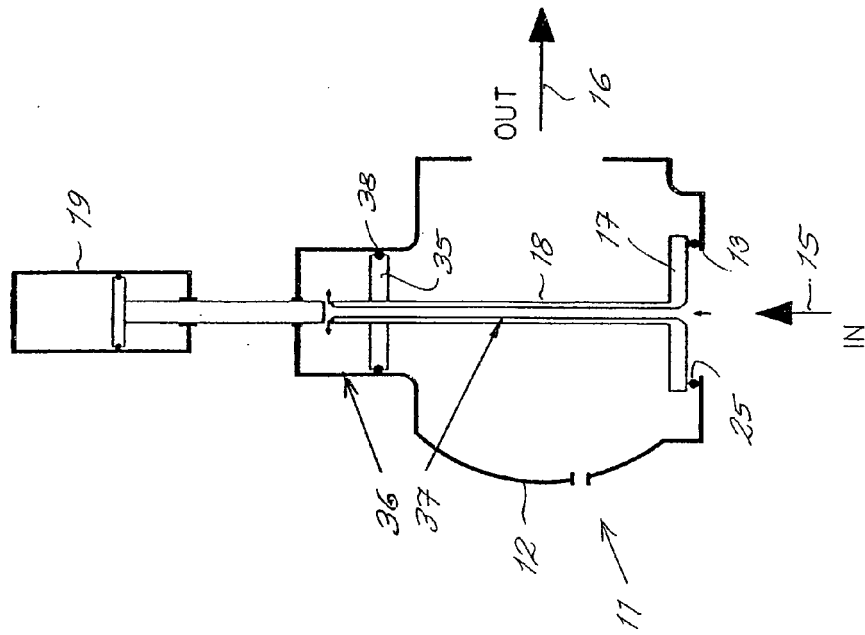

Fig. 5

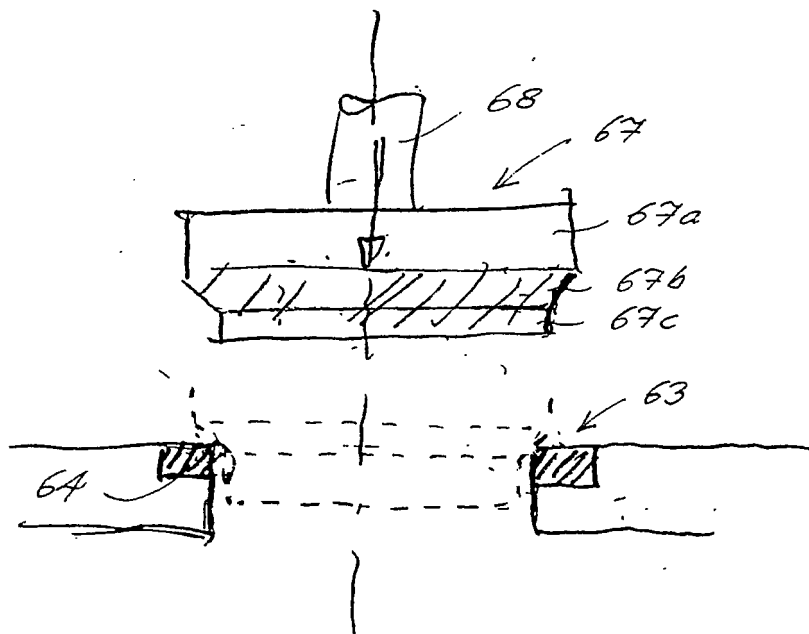

Fig. 7

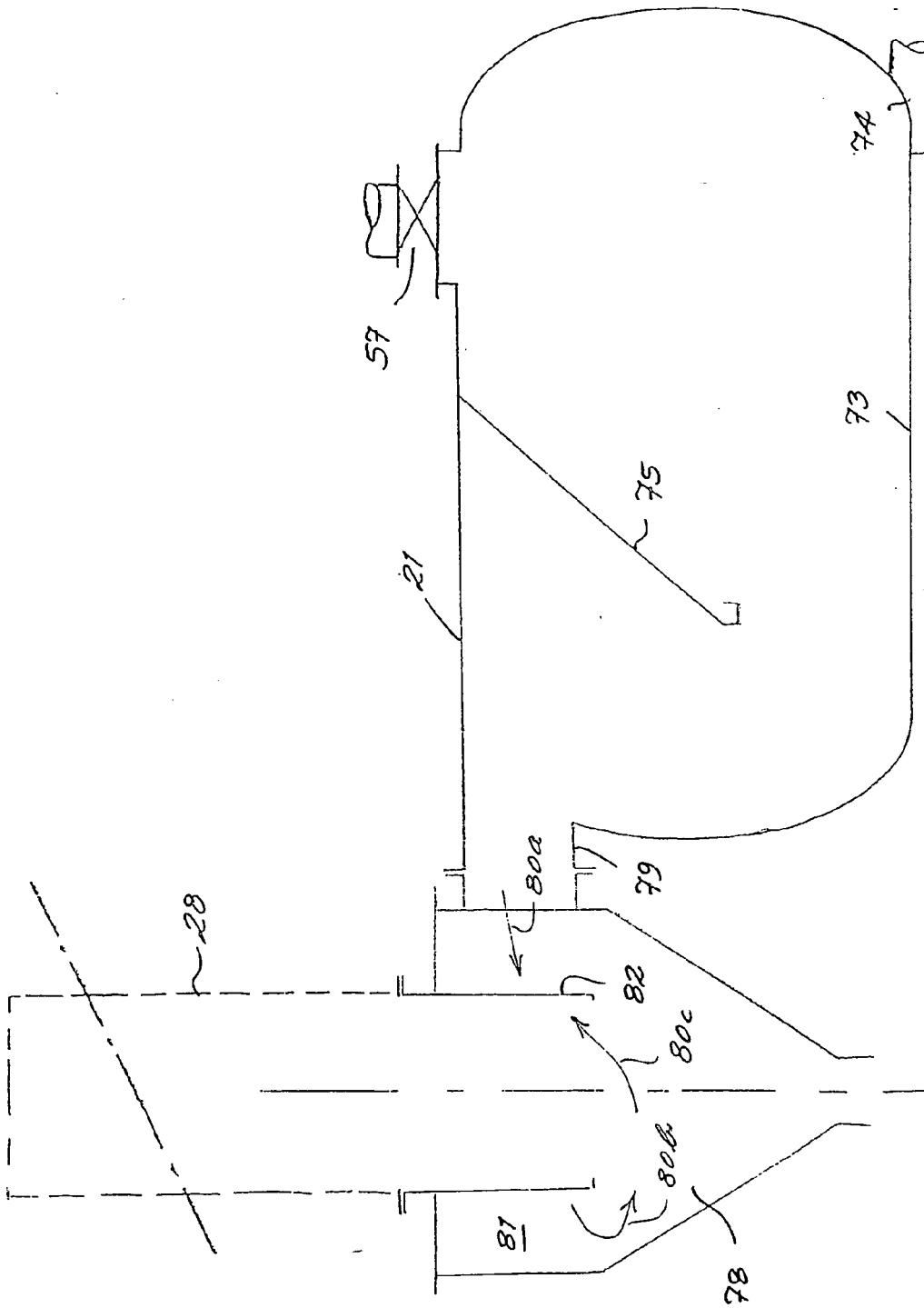

Fig. 8

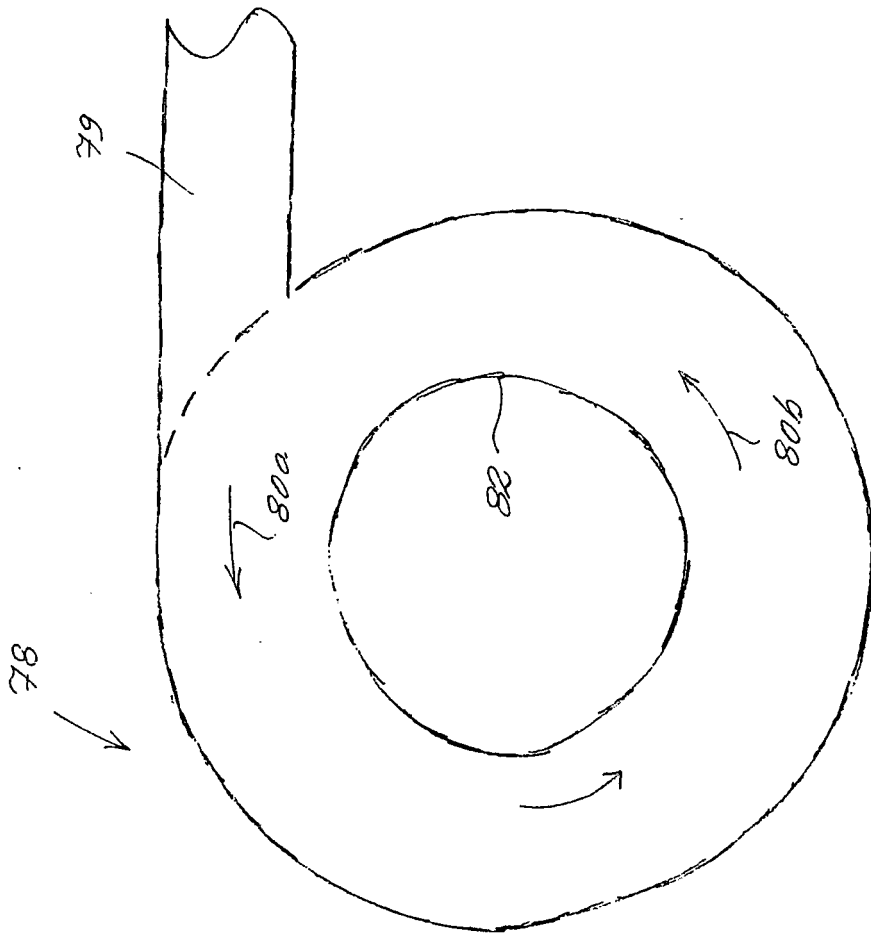

Fig. 9

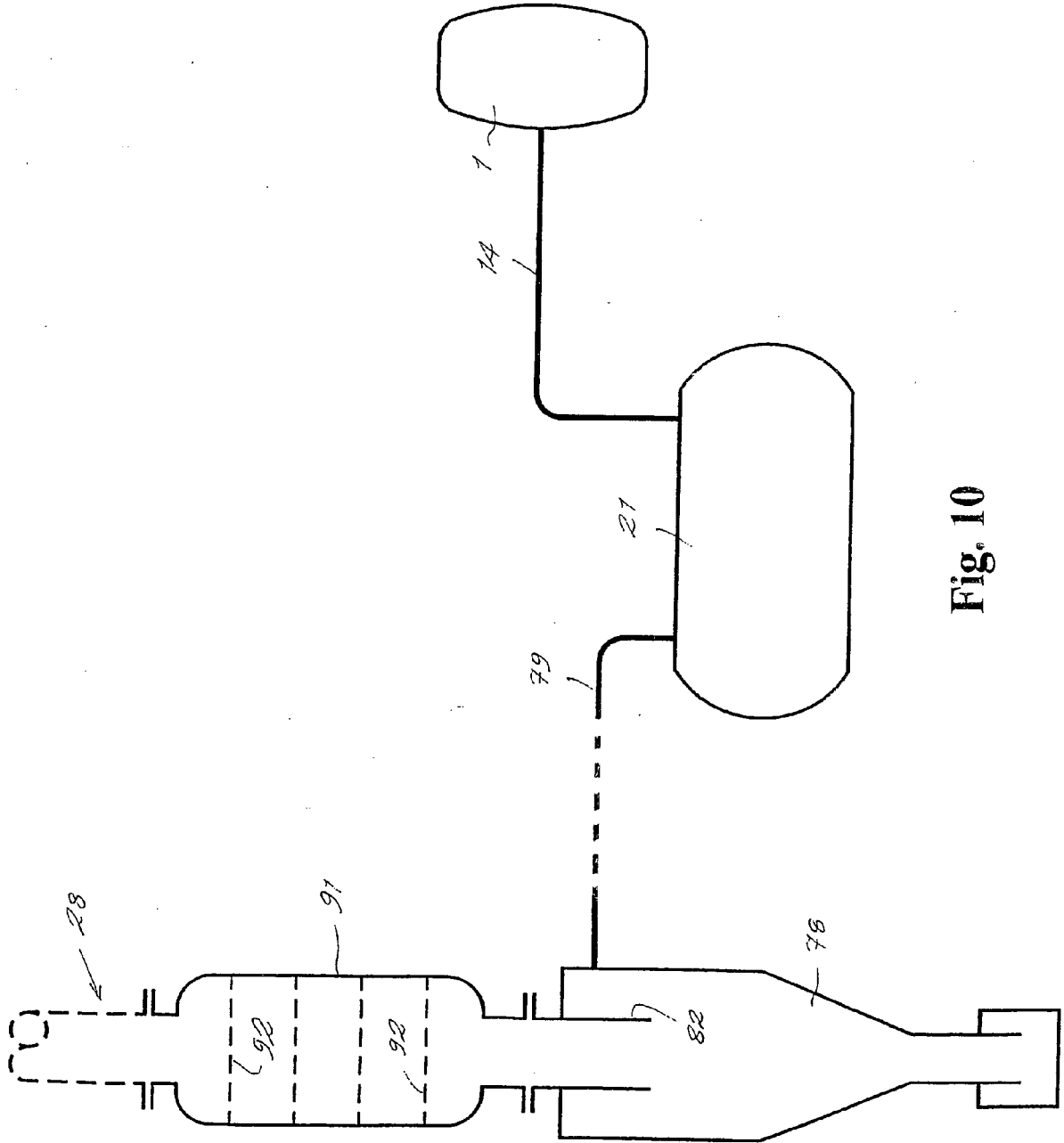

Fig. 10

REFERENCES CITED IN THE DESCRIPTION

This list of references cited by the applicant is for the reader's convenience only. It does not form part of the European patent document. Even though great care has been taken in compiling the references, errors or omissions cannot be excluded and the EPO disclaims all liability in this regard.

Patent documents cited in the description

- IE 0100076 W [0002]
- WO 0193704 A [0002] [0016] [0017] [0018] [0022] [0037]
- US 3811279 A [0003]