



(11) **EP 1 605 169 B9**

(12) **CORRECTED EUROPEAN PATENT SPECIFICATION**

(15) Correction information:

Corrected version no 1 (W1 B1)
Corrections, see
Claims EN

(51) Int Cl.:

F15B 11/042 ^(2006.01) **F15B 11/044** ^(2006.01)

(48) Corrigendum issued on:

11.03.2009 Bulletin 2009/11

(45) Date of publication and mention
of the grant of the patent:

26.09.2007 Bulletin 2007/39

(21) Application number: **05076256.6**

(22) Date of filing: **30.05.2005**

(54) **Hydraulic actuating device**

Hydraulische Betätigungseinrichtung

Dispositif d'actionnement hydraulique

(84) Designated Contracting States:

DE FR GB NL

(30) Priority: **11.06.2004 NL 1026393**

(43) Date of publication of application:

14.12.2005 Bulletin 2005/50

(73) Proprietor: **Actuant Corporation**

Glendale, Wisconsin 53209-3703 (US)

(72) Inventor: **Mentink, Laurentius Andreas Gerardus**
7483 AC Haaksbergen (NL)

(74) Representative: **Houben, Christiaan Hein Willem**
Frans

Exter Polak & Charlouis B.V.

P.O. Box 3241

2280 GE Rijswijk (NL)

(56) References cited:

EP-A- 1 052 127

DE-A1- 10 253 340

DE-B3- 10 253 871

EP 1 605 169 B9

Description

[0001] The invention relates to a hydraulic actuating device in accordance with the preamble of claim 1.

[0002] The applicant is aware of a hydraulic actuating device as shown in Fig. 1. This known hydraulic actuating device will be described below in the present application.

[0003] One significant drawback of this hydraulic actuating device is that the resulting force with which the piston rod is extended is low, since during the extension the pressure acting on the piston on the piston rod side counteracts the pressure acting on the piston from the base side. The effective surface area of the piston on which the hydraulic pressure acts is therefore limited, when the piston rod is being extended, to a surface area equal to that of the cross section of the piston rod.

[0004] To overcome this drawback, it has in the past been proposed that a control valve assembly identical to the control valve assembly which is present in the second connecting line also be incorporated in the first connecting line. This control valve assembly in the first connecting line is then driven by the control device of the hydraulic actuating device. However, this makes the actuating device more expensive and more complex to drive. A hydraulic actuating device of this type is known, for example, from EP 1052127.

[0005] A pneumatic actuating device is disclosed in DE 10253340 A1.

[0006] It is an object of the invention to provide a hydraulic actuating device which is simple to drive and can also deliver a high force when extending the piston rod.

[0007] The invention achieves this object by means of a hydraulic actuating device according to claim 1.

[0008] The presence of a first control valve assembly and a second control valve assembly in the hydraulic actuating device according to claim 1 ensures that in each case one of the working chambers is in communication with the pump and the other working chamber is in communication with the reservoir. As a result, in one of the working chambers the pressure is in each case at least virtually equal to the pressure in the reservoir, which pressure is considerably lower than the pressure which is delivered by the pump (the pressure which prevails in the reservoir is typically 1 atmosphere). The reservoir pressure will therefore deliver scarcely any force on the piston which counteracts the piston movement caused by the pressure delivered by the pump.

[0009] The result of this measure is that the force which the actuator can deliver can be utilized entirely to extend the piston rod.

[0010] In the hydraulic actuating device according to claim 1, use is made of the hydraulic pressure prevailing in the second connecting line in order to drive the first control valve assembly. This hydraulic pressure, which is either (at least virtually) equal to the pressure in the reservoir or (at least virtually) equal to the pressure which is applied by the pump, during use is always present in the hydraulic actuating device. As a result, there is no

need to provide for separate driving of the first control valve assembly by the control device of the hydraulic actuating device.

[0011] In a first advantageous embodiment, the first control valve assembly is designed in such a way that it comprises a switching element which determines whether the first connection is connected to the pressure port of the pump or to the reservoir. In this embodiment, this switching element has a primary position and a secondary position. When no force is being exerted on the switching element, the switching element is in its primary position. An external force can move the switching element into its secondary position. As long as the external force continues to be present, the switching element is in its secondary position. If the external force is eliminated, restoring means which are provided in the first control valve assembly move the switching element back into its primary position. These restoring means preferably comprise a spring, more preferably a compression spring.

[0012] In this first advantageous embodiment, the external force is delivered by the hydraulic actuating means of the first control valve assembly by virtue of the switching element being provided with a surface on which a hydraulic pressure can be exerted. The hydraulic control connection (which forms part of the hydraulic actuating means) in this embodiment ensures that the pressure prevailing in the second connecting line acts on the said surface of the switching element. With a high pressure in the second connecting line - which high pressure occurs when the second connection is in communication with the pressure port of the pump - this pressure ensures that the switching element is moved into and held in its secondary position, counter to the force of the restoring means. If the second control valve assembly is switched to its second position, in which the second connection is connected to the reservoir, the pressure in the second connecting line drops to approximately the level of the pressure in the reservoir, and the restoring means move the switching element back into its primary position and hold the switching element in that position.

[0013] The hydraulic actuator preferably comprises a single piston rod. However, it is also possible to use a continuous piston rod.

[0014] In a second advantageous embodiment, the first control valve assembly comprises a displaceable switching element and a first and second seat for the switching element. When the switching element is in the first seat, the first connection is connected to the reservoir. When the switching element is in the second seat, the first connection is connected to the pressure port of the pump.

[0015] In this second embodiment, the hydraulic actuating means also comprise a control cylinder with a control piston and a primary connection, which primary connection is connected to the hydraulic control connection, and an actuating element which is designed to be driven by the control piston, for actuating the switching element as a function of the position of the control piston.

[0016] When, in this second embodiment, the first (i.e. high) pressure prevails in the second connecting line, this second pressure also acts on the control piston, with the result that the latter is displaced. The control piston is connected to an actuating element which moves with the control piston. This actuating element acts on the switching element, in such a manner that the switching element moves into the first seat. As a result, the first connection and the pressure port of the pump are disconnected and the first connection and the reservoir are connected.

[0017] If the pressure in the second connecting line then drops because the second control valve assembly is switched to its second position, restoring means move the control piston back together with the actuating means and the switching element, in such a manner that the switching element moves into the second seat. As a result, the first connection and reservoir are disconnected and the first connection and pressure port of the pump are connected.

[0018] The switching element is preferably a ball.

[0019] The actuating element is preferably a piston rod.

[0020] In a further advantageous embodiment, the first control valve assembly comprises a first valve and a second valve. The hydraulic actuating means comprise a first control unit for actuating the first valve and a second control unit for actuating the second valve. The first valve has a first primary port leading to the first connecting line and a first secondary port leading to the reservoir. The second valve has a second primary port leading to the first connecting line and a second secondary port leading to the pressure port.

[0021] When a first hydraulic pressure prevails in the second connecting line, the first valve is open and the second valve closed, so that the first connection of the hydraulic actuator is in communication with the reservoir. When a second hydraulic pressure prevails in the second connecting line, the first valve is closed and the second valve open, so that the first connection of the hydraulic actuator is in communication with the pressure port.

[0022] It is preferable for both the first and second valves to be nonreturn valves.

[0023] In an advantageous variant of the third embodiment, the first valve comprises a first switching element, and the second valve comprises a second switching element. In this variant, the hydraulic actuating means include a first control unit for operating the first valve and a second control unit for operating the second valve. At least one of the control units comprises:

- a control cylinder having a control piston and a primary connection,
- an actuating element which is designed to be driven by the control piston, for actuating the switching element of the associated valve as a function of the position of the control piston, a hydraulic control connection forming a connection between the primary

connection and the second connecting line.

[0024] Hydraulic actuating devices in various embodiments of the invention will be explained in more detail below with reference to the appended drawing, which shows non-limiting exemplary embodiments and in which:

- Fig. 1a-b shows hydraulic actuating devices which are known from the prior art,
- Fig. 2 shows a first embodiment of the hydraulic actuating device according to the invention,
- Fig. 3 shows a second embodiment of the hydraulic actuating device according to the invention,
- Fig. 4 shows a third embodiment of the hydraulic actuating device according to the invention, and
- Fig. 5 shows a variant of the third embodiment as shown in Figure 4.

[0025] Fig. 1a shows the hydraulic actuating device which is known to the applicant from the prior art. This hydraulic actuating device comprises an actuator 1, with the first working chamber 6 being in communication, via a first connection 4 and a first connecting line 15, with pressure port 11 of pump 10. A second working chamber 7 is connected to a second connecting line 16 via a second connection 5. In this connecting line 16 there is a control valve assembly 19. This control valve assembly 19 ensures that the second working chamber 7 can be connected either to the pressure port 11 of the pump 10 or to a reservoir 12. The control valve assembly 19 is driven by a control device 50.

[0026] If, in the known hydraulic actuating device shown in Fig. 1a, it is desired to retract piston rod 3 of the hydraulic actuator 1, the control device 50 switches the control valve assembly 19 in such a manner that the second connecting line 16 connects the second working chamber 7 of the actuator 1 to the reservoir 12. However, if it is desired to extend the piston rod 3, the control device 50 has to switch the control valve assembly 19 in such a manner that the connecting line 16 connects the second working chamber 7 to the pressure port 11 of the pump 10. It can be seen from Fig. 1a that the pressure which is applied by the pump 10 in that situation acts on both sides of piston 2 of actuator 1. On account of the difference in active surface area of the two sides of the piston 2, which difference is caused by the presence of piston rod 3, a low resulting force remains, allowing the piston to move in such a manner that the piston rod 3 is extended.

[0027] In the hydraulic actuating device according to the present invention only the second control valve assembly is coupled to a control device.

[0028] In Fig. 1b, this problem is solved by arranging a control valve assembly 18 in connecting line 15. This control valve assembly 18 is driven by control device 50, making control more complex.

[0029] Fig. 2 shows a first embodiment of the hydraulic

actuating device according to the invention. This hydraulic actuating device, in addition to the elements which were already known from the hydraulic actuating device according to the prior art, comprises a first control valve assembly 18, which is arranged in the first connecting line 15 connecting the first connection 4 of the actuator 1 to the pressure port 11 of the pump 10 or to the reservoir 12, depending on the position of the first control valve assembly 18. The hydraulic actuating device is set up in such a way that in each case one control valve assembly 18, 19 realizes a connection to the pressure port 11 of pump 10, and the other control valve assembly 18, 19 realizes a connection to the reservoir 12. This prevents the pressure delivered by the pump 10 from acting on both sides of the piston 2 of the actuator 1, which would lead to only a low resulting force displacing the piston 2 with the piston rod 3.

[0030] To prevent control of the hydraulic actuating device from becoming unnecessarily complex, in the hydraulic actuating device according to the invention there are hydraulic actuating means 30 for driving the first control valve assembly 18. In the embodiment shown in Fig. 2, these hydraulic actuating means 30 comprise a hydraulic control connection 31. Such a control is sometimes in the art called a pilot line. This hydraulic control connection 31 is coupled to the second connecting line 16, so that the pressure in the hydraulic control connection 31 is the same as in the second connecting line 16. The pressure which prevails in the control connection 31 can exert an external force on the first control valve assembly 18, by means of which the first control valve assembly 18 is actuated.

[0031] In the embodiment shown in Fig. 2, this is specifically realized by allowing the hydraulic pressure to act on an active surface of a switching element from the control valve assembly 18. This switching element determines whether the first connection 4 of the actuator 1 is in communication with the pump 10 or the reservoir 12. A restoring means 20 also acts on the switching element. A restoring means 20 of this type may be designed as a compression spring. The force delivered by the restoring means 20 on the switching element is selected to be such that when the pressure applied by the pump 10 prevails in the second connecting line 16, and therefore in the hydraulic control device 31, the force which is delivered by this hydraulic pressure is greater than the force which is delivered by the restoring means 20. However, if the pressure which results from the second connection 5 being connected to the reservoir 12 prevails in the second connecting line 16 and therefore in the hydraulic control connection 31, the force which is delivered by the restoring means 20 is higher than the force which is caused by the pressure in the hydraulic control connection 31.

[0032] It will therefore be clear to the person skilled in the art that a further advantage of the hydraulic actuating device according to the invention in general (i.e. not specifically in this embodiment) is that it is no longer necessary to create a difference in active surface area between

the two sides of the piston 2 of the hydraulic actuator. In specific terms, this means that in the hydraulic actuating device according to the invention, it would also be possible for a continuous piston rod to be used in the actuator 1.

[0033] Fig. 3 shows a second advantageous embodiment of the hydraulic actuating device according to the invention. The difference from the embodiment shown in Fig. 2 lies in particular in the structure of the first control valve assembly 18. In the embodiment shown in Fig. 3, the first control valve assembly 18 comprises a displaceable switching element 23, which is preferably designed as a ball. The first control valve assembly 18 also includes a first seat 21 and a second seat 22. These seats 21, 22 for the switching element 23 are designed in such a manner that when the switching element 23 is in one of the seats 21, 22, the connecting line 15 which is connected to the corresponding seat 21, 22 is closed off by the switching element 23. In the example shown in Fig. 3, the first seat 21 is connected to the first line part 15a of the first connecting line 15, which first line part 15a is connected to the pressure port 11 of pump 10. A second part 15b of the first connecting line 15 is connected to the reservoir 12. When the switching element 23 is in the first seat, line part 15a is blocked and hydraulic fluid can flow from the first connection 4 to the reservoir 12. When the switching element 23 is in the second seat 22, the path to the reservoir 12 is closed. The hydraulic fluid can then flow from the pressure port of the pump 11 to the first connection 4.

[0034] To actuate the switching element 23, in the embodiment shown in Fig. 3 there is an actuating element 35 which is driven by a control cylinder 33. This control cylinder 33 is provided with a primary connection 36, to which the hydraulic control connection 31 is connected. When the high pressure applied by the pump prevails in the second connection line 16 and therefore in the hydraulic control connection 31, the piston of the control cylinder 33 is pushed away by this hydraulic pressure, so that the actuating element 35 presses the switching element 33 into the first seat. However, if the pressure in the second connecting line 16 becomes low as a result of the second connection of the hydraulic actuator 1 being connected to the reservoir 12, restoring means (not shown) move the piston 34 of the control cylinder 33 back towards the primary connection 36. As a result, the actuating element 35 brings the switching element 23 with it, specifically in such a manner that the switching element 23 moves into the second seat 22.

[0035] This second embodiment likewise means that the control device 50 of the hydraulic actuating device has only to drive the second control valve assembly 19. After all, the first control valve assembly 18 is driven by the hydraulic pressure prevailing in the second connecting line 16.

[0036] Fig. 4 shows a third advantageous embodiment of the hydraulic actuating device according to the invention. In the embodiment shown in Fig. 4, the hydraulic

actuating device comprises a first valve 40 and a second valve 45. The first valve 40 has a first primary port leading to the first connecting line 15 and a first secondary port leading to the reservoir 12. The second valve 45 has a second primary port leading to the first connecting line 15 and a second secondary port leading to the pressure port 11 of pump 10. The valves 40, 45 are each driven by a dedicated control connection 31a, 31b. The hydraulic actuating means 30, of which the hydraulic control connections 31a and 31b form part, are designed in such a way that when a hydraulic pressure applied by the pump 10 prevails in the second connecting line 16 the first valve 40 is open and the second valve 45 is closed. As a result, hydraulic fluid flows from the first connection 4 of the hydraulic actuator 1 to the reservoir 12. However, if a low hydraulic pressure prevails in the second connecting line 16, as a result of the second connection 5 of the actuator 1 being connected to the reservoir 12, the hydraulic actuating means 30 ensure that the first valve 40 is closed and the second valve 45 is open. As a result, hydraulic fluid can be passed from the pump 10 to the first connection 4 of the actuator 1.

[0037] The two valves 40, 45 can be designed as non-return valves.

[0038] Fig. 5 shows an advantageous variant of the embodiment shown in Fig. 4. In the embodiment shown in Fig. 5, the first valve 40 comprises a first switching element 23a. This first switching element 23a is actuated by control cylinder 33a via an actuating element 45a. This control cylinder 33a is connected to a hydraulic control connection 31a, which is in open communication with the second connecting line 16. The first valve 40 closes the passage of fluid from the first connection 4 to the reservoir 12 when the switching element 23a is moved into seat 22a by the actuating element 35a. This occurs when the pressure in the second connecting line 16 is low. In that case, piston 34b of control cylinder 33b also moves towards the primary connection 36b. As a result, switching element 23b is moved out of the seat 21b by actuating element 35b. This realizes a through connection between the pressure port 11 of pump 10 and the first connection 4 of the hydraulic actuator 1.

[0039] When the pressure in the second connecting line is relatively high, which is caused by a connection being created between the pressure port 11 of the pump 10 and the second connection 5 of the actuator 1, the two pistons 34a, 34b of the control cylinders 33a, 33b move away from their primary connections 36a, 36b. The consequence of this is that the first switching element 23a is pressed out of its seat 22a, and that the second switching element 23b is pressed into its seat 21b. As a result, the first connection 4 and the pressure port 11 of the pump 10 are disconnected, and the first connection 4 and the reservoir 12 are connected.

Claims

1. Hydraulic actuating device for a movable component of a vehicle, in particular a closure element for closing an opening in a vehicle body, such as for example a movable roof, such as a folding roof or a retractable hard top, comprising:

- a hydraulic actuator (1) having a first connection (4) and a second connection (5), a piston (2), a first working chamber (6), which is in communication with the first connection, a second working chamber (7), which is in communication with the second connection,
- a pump (10) having a pressure port (11) for delivering a pressurized hydraulic fluid,
- a reservoir (12) for hydraulic fluid,
- a first connecting line (15) leading from the pressure port of the pump to the first connection of the hydraulic actuator,
- a second connecting line (16) leading from the pressure port of the pump to the second connection of the hydraulic actuator,
- a control device,
- a first control valve assembly (18), which is located in the first connection line and has a port leading to the first connection, a port leading to the pressure port of the pump and a port leading to the reservoir,
- a second control valve assembly (19), which is located in the second connection line and has a port leading to the second connection, a port leading to the pressure port of the pump and a port leading to the reservoir, the second control valve assembly being coupled to the control device (50) for switching the second control valve assembly on command between a first position, in which the second connection is connected to the pressure port, and a second position, in which the second connection is connected to the reservoir,

characterized in that only the second control valve assembly (19) is coupled to the control device (50), **and in that**

the first control valve assembly (18) is provided with hydraulic actuating means, which hydraulic actuating means comprise at least one hydraulic control connection (31), which is in communication with the second connection of the hydraulic actuator, the hydraulic actuating means being designed to ensure that when a first hydraulic pressure is present at the second connection - which first hydraulic pressure is the consequence of a connection being formed between the second connection and the pressure port - the first connection is connected to the reservoir, and that when a second hydraulic pressure is present at the second connection - which second

hydraulic pressure is the consequence of a connection being formed between the second connection and the reservoir - the first connection is connected to the pressure port of the pump.

2. Hydraulic actuating device according to claim 1, wherein the first control valve assembly (18) comprises a switching element (23), which switching element can be displaced between a primary position and a secondary position, which switching element has an active surface, on which, during operation, the hydraulic pressure from the second connecting line acts via the hydraulic control line (31), and wherein the first control valve assembly comprises restoring means (20) which are designed to deliver a force to the switching element, in such a manner that the balance between the force which is delivered by the restoring means and the force which is delivered by the hydraulic pressure on the active surface of the switching element determines whether the switching element is in the primary position or the secondary position.
3. Hydraulic actuating device according to claim 2, wherein the restoring means comprise a spring.
4. Hydraulic actuating device according to one of the preceding claims, wherein the actuator comprises a piston rod (3), an end of which is secured to the piston, and wherein the first working chamber (6) is located on the same side of the piston as the piston rod.
5. Hydraulic actuating device according to one of the preceding claims, wherein the first control valve assembly (18) comprises a displaceable switching element, as well as a first seat (21) and a second seat (22) for the switching element (23), switching element, when it is in the first seat, connecting the first connection to the reservoir and, when it is in the second seat, connecting the first connection to the pressure port, and wherein the hydraulic actuating means also comprise:
 - a control cylinder (33) having a control piston (34) and a primary connection (36), which primary connection is connected to the hydraulic control connection (31),
 - an actuating element (35) which is designed to be driven by the control piston in order to actuate the switching element as a function of the position of the control piston.
6. Hydraulic actuating device according to claim 5, wherein the switching element (23) is a ball.

7. Hydraulic actuating device according to one of claims 5 or 6, wherein the actuating element (35) is a piston rod which is connected to the control piston.
- 5 8. Hydraulic actuating device according to claim 1, wherein the first control valve assembly (18) comprises a first valve (40) and a second valve (45), and wherein the hydraulic actuating means (35) comprise a first control unit for actuating the first valve and a second control unit for actuating the second valve,
 - 10 the first valve having a first primary port leading to the first connecting line and a first secondary port leading to the reservoir, and the second valve having a secondary primary port leading to the first connecting line and a second secondary port leading to the pressure port, wherein when a first hydraulic pressure prevails in the second connecting line, the first valve (40) is open and the second valve (45) is closed, so that the first connection of the hydraulic actuator is in communication with the reservoir, and wherein when a second hydraulic pressure prevails in the second connecting line, the first valve (40) is closed and the second valve (45) is open, so that the first connection of the hydraulic actuator is in communication with the pressure port.
- 15 9. Hydraulic actuating device according to claim 8, wherein both the first valve and the second valve are non-return valves.
- 20 10. Hydraulic actuating device according to claim 8, wherein the first valve comprises a first switching element (23a), and the second valve comprises a second switching element (23b), wherein the hydraulic actuating means comprise a first control unit for actuating the first valve and a second control unit for actuating the second valve, at least one of the control units comprising:
 - 25 - a control cylinder having a control piston and a primary connection,
 - 30 - an actuating element which is designed to be driven by the control piston, in order to actuate the switching element of the respective valve as a function of the position of the control piston,
 and wherein a hydraulic control connection forms a connection between the primary connection and the second connecting line.
- 35 11. Hydraulic actuating device according to claim 10, wherein the switching element is a ball.
- 40 12. Hydraulic actuating device according to one of claims 10 or 11, wherein the actuating element is a piston rod which is connected to the control piston.
- 45
- 50
- 55

13. Vehicle, provided with a movable component, in particular a closure element for closing an opening in a vehicle body, such as for example a movable roof, such as a folding roof or a retractable hard top, which is provided with a hydraulic actuating device according to one of the preceding claims.

Patentansprüche

1. Hydraulische Betätigungsanordnung für eine bewegliche Komponente eines Fahrzeugs, insbesondere für ein Schließelement für das Schließen einer Öffnung in einem Fahrzeugkörper, wie z.B. ein bewegliches Dach, wie etwa ein Faltdach oder ein rückziehbares Hardtop, die umfasst:

- ein hydraulisches Stellglied (1) mit einem ersten Anschluss (4) und einem zweiten Anschluss (5), einem Kolben (2), einer ersten Arbeitskammer (6), die mit dem ersten Anschluss verbunden ist, einer zweiten Arbeitskammer (7), die mit dem zweiten Anschluss verbunden ist,
- eine Pumpe (10) mit einem Druckanschluss (11) für die Abgabe eines unter Druck stehenden hydraulischen Fluids,
- ein Reservoir (12) für das hydraulische Fluid,
- eine erste Verbindungsleitung (15), die von dem Druckanschluss der Pumpe zu dem ersten Anschluss des hydraulischen Stellglieds führt,
- eine zweite Verbindungsleitung (16), die von dem Druckanschluss der Pumpe zu dem zweiten Anschluss des hydraulischen Stellglieds führt,
- eine Steuerungsvorrichtung,
- eine erste Steuerungsventilvorrichtung (18), die in der ersten Verbindungsleitung liegt und einen Anschluss, der zu dem ersten Anschluss führt, einen Anschluss, der zu dem Druckanschluss der Pumpe führt, und einen Anschluss hat, der zu dem Reservoir führt,
- eine zweite Steuerungsventilvorrichtung (19), die in der zweiten Verbindungsleitung liegt und einen Anschluss, der zu dem zweiten Anschluss führt, einen Anschluss, der zu dem Druckanschluss der Pumpe führt, und einen Anschluss hat, der zu dem Reservoir führt, wobei die zweite Steuerungsventilvorrichtung mit der Steuerungsvorrichtung (50) gekoppelt ist für das Schalten der zweiten Steuerungsventilvorrichtung auf Kommando zwischen einer ersten Position, in der der zweite Anschluss mit dem Druckanschluss verbunden ist, und einer zweiten Position, in der der zweite Anschluss mit dem Reservoir verbunden ist,
- **dadurch gekennzeichnet, dass**

nur die zweite Steuerungsventilvorrichtung (19) mit

der Steuerungsvorrichtung (50) gekoppelt ist, und dass die erste Steuerungsventilvorrichtung (18) ausgerüstet ist mit hydraulischen Betätigungsmitteln, die mindestens eine hydraulische Steuerungsverbindung (31) umfassen, die mit dem zweiten Anschluss des hydraulischen Stellglieds in Verbindung steht, wobei die hydraulischen Betätigungsmittel ausgelegt sind, um sicherzustellen, dass bei Vorliegen eines ersten hydraulischen Drucks an dem zweiten Anschluss, was die Konsequenz einer zwischen dem zweiten Anschluss und dem Druckanschluss gebildeten Verbindung ist, der erste Anschluss mit dem Reservoir verbunden ist, und dass bei Vorliegen eines zweiten hydraulischen Drucks an dem zweiten Anschluss, was die Konsequenz einer zwischen dem zweiten Anschluss und dem Reservoir gebildeten Verbindung ist, der erste Anschluss mit dem Druckanschluss verbunden ist.

2. Hydraulische Betätigungsanordnung nach Anspruch 1, wobei die erste Steuerungsventilvorrichtung (18) ein Schaltelement (23) umfasst, das zwischen einer Hauptposition und einer Nebenposition versetzt werden kann,
- wobei das Schaltelement eine aktive Oberfläche hat, auf die bei Betrieb der hydraulische Druck von der zweiten Verbindungsleitung über die hydraulische Steuerungsleitung (31) einwirkt, und wobei die erste Steuerungsventilvorrichtung (18) Rückstellmittel (20) umfasst, die ausgelegt sind, um eine Kraft auf das Schaltelement derart auszuüben, dass das Gleichgewicht zwischen der von den Rückstellmitteln ausgeübten Kraft und der von dem hydraulischen Druck auf die aktive Oberfläche ausgeübten Kraft bestimmt, ob das Schaltelement in der Hauptposition oder in der Nebenposition ist.
3. Hydraulische Betätigungsanordnung nach Anspruch 2, wobei die Rückstellmittel eine Feder umfassen.
4. Hydraulische Betätigungsanordnung nach irgendeinem der vorstehenden Ansprüche, wobei das Stellglied eine Kolbenstange (3) umfasst, deren eines Ende am Kolben befestigt ist, und wobei die erste Arbeitskammer (6) auf derselben Seite des Kolbens wie die Kolbenstange liegt.
5. Hydraulische Betätigungsanordnung nach irgendeinem der vorstehenden Ansprüche, wobei die erste Steuerungsventilvorrichtung (18) ein versetzbares Schaltelement wie auch einen ersten Sitz (21) und einen zweiten Sitz (22) für das Schaltelement (23) umfasst, wobei das Schaltelement beim Anliegen an dem ersten Sitz den ersten Anschluss mit dem Reservoir und beim Anliegen an dem zweiten Sitz den ersten Anschluss mit dem Druckanschluss verbindet, und

wobei die hydraulischen Betätigungsmittel ebenfalls umfassen:

- einen Steuerungszyylinder (33) mit einem Steuerungskolben (34) und einer Hauptverbindung (36), die mit der hydraulischen Steuerungsverbindung (31) verbunden ist, 5
 - ein Betätigungselement (35), das ausgelegt ist, um von dem Steuerungskolben angetrieben zu werden, um das Schaltelement als eine Funktion der Position des Steuerungskolbens zu betätigen. 10
6. Hydraulische Betätigungsanordnung nach Anspruch 5, wobei das Schaltelement (23) eine Kugel ist. 15
 7. Hydraulische Betätigungsanordnung nach Anspruch 5 oder 6, wobei das Betätigungselement (35) eine Kolbenstange ist, die mit dem Steuerungskolben verbunden ist. 20
 8. Hydraulische Betätigungsanordnung nach Anspruch 1, wobei die erste Steuerungsventilvorrichtung (18) ein erstes Ventil (40) und ein zweites Ventil (45) umfasst, und wobei das hydraulische Betätigungselement (35) eine erste Steuerungseinheit für das Betätigen des ersten Ventils und eine zweite Steuerungseinheit für das Betätigen des zweiten Ventils umfasst, 25
wobei das erste Ventil einen ersten Hauptanschluss, der zu der ersten Verbindungsleitung führt, und einen ersten Nebenanschluss hat, der zu dem Reservoir führt, und das zweite Ventil einen zweiten Hauptanschluss, der zu der ersten Verbindungsleitung führt, und einen zweiten Nebenanschluss hat, der zu dem Druckanschluss führt, 30
wobei bei Vorherrschen eines ersten hydraulischen Drucks in der zweiten Verbindungsleitung das erste Ventil (40) geöffnet und das zweite Ventil (45) geschlossen ist, so dass der erste Anschluss des hydraulischen Stellglieds mit dem Reservoir in Verbindung steht, und wobei bei Vorherrschen eines zweiten hydraulischen Drucks in der zweiten Verbindungsleitung das erste Ventil (40) geschlossen und das zweite Ventil (45) geöffnet ist, so dass der erste Anschluss des hydraulischen Stellglieds mit dem Druckanschluss in Verbindung steht. 35
 9. Hydraulische Betätigungsanordnung nach Anspruch 8, wobei sowohl das erste Ventil als auch das zweite Ventil Einwegventile sind. 50
 10. Hydraulische Betätigungsanordnung nach Anspruch 8, wobei das erste Ventil ein erstes Schaltelement (23a) und das zweite Ventil ein zweites Schaltelement (23b) umfasst, 55
wobei die hydraulischen Betätigungsmittel eine er-

ste Steuerungseinheit für das Betätigen des ersten Ventils und eine zweite Steuerungseinheit für das Betätigen des zweiten Ventils umfasst, wobei mindestens eine der Steuerungseinheiten umfasst:

- einen Steuerungszyylinder mit einem Steuerungskolben und einem Hauptanschluss
 - ein Betätigungselement, das ausgelegt ist, um durch den Steuerungskolben angetrieben zu werden, um das Schaltelement des jeweiligen Ventils als eine Funktion der Position des Steuerungskolbens zu betätigen,
- und wobei eine hydraulische Steuerungsverbindung eine Verbindung zwischen dem Hauptanschluss und der zweiten Verbindungsleitung bildet.
11. Hydraulische Betätigungsanordnung nach Anspruch 10, wobei das Schaltelement (23) eine Kugel ist. 20

12. Hydraulische Betätigungsanordnung nach Anspruch 10 oder 11, wobei das Betätigungselement eine Kolbenstange ist, die mit dem Steuerungskolben verbunden ist. 25
13. Fahrzeug, das mit einer beweglichen Komponente ausgerüstet ist, insbesondere mit einem Schließelement für das Schließen einer Öffnung in einem Fahrzeugkörper, wie z.B. ein bewegliches Dach, wie ein Faltdach oder ein rückziehbares Hardtop, das mit einer hydraulischen Betätigungsanordnung nach einem der vorstehenden Ansprüche ausgerüstet ist. 30

Revendications

1. Dispositif d'actionnement hydraulique pour un composant déplaçable d'un véhicule, en particulier un élément de fermeture pour fermer une ouverture dans une carrosserie de véhicule, tel que par exemple un toit mobile, telle qu'un toit pliable ou un toit rétractable, comprenant : 40
 - un actionneur hydraulique (1) ayant une première connexion (4) et une deuxième connexion (5), un piston (2), une première chambre de travail (6), en communication avec la première connexion, une deuxième chambre de travail (7), en communication avec la deuxième connexion, 45
 - une pompe (10), ayant un orifice à pression (11) pour délivrer un fluide hydraulique, placé sous pression,
 - un réservoir (12) pour du fluide hydraulique,
 - une première tuyauterie de connexion (15), menant de l'orifice à pression de la pompe à la première connexion de l'actionneur hydraulique.

que,

- une deuxième tuyauterie de connexion (16), menant de l'orifice à pression de la pompe à la deuxième connexion de l'actionneur hydraulique,

- un dispositif de commande,

- un premier ensemble de soupape de commande (18), placé dans la première tuyauterie de connexion, et ayant un orifice menant à la première connexion, un orifice menant à un orifice à pression de la pompe et un orifice menant au réservoir,

- un deuxième ensemble de soupape de commande (19), placé dans la deuxième tuyauterie de connexion, et ayant un orifice menant à la deuxième connexion, un orifice menant à l'orifice à pression de la pompe et un orifice menant au réservoir, le deuxième ensemble de soupape de commande étant couplé au dispositif de commande (50) pour commuter le deuxième ensemble de soupape de commande, sur instruction, entre une première position, à laquelle la deuxième connexion est reliée à l'orifice à pression, et une deuxième position, à laquelle la deuxième connexion est reliée au réservoir,

caractérisé en ce que seul le deuxième ensemble de soupape de commande (19) est couplé au dispositif de commande (50), et **en ce que**

le premier ensemble de soupape de commande (18) est muni de moyens d'actionnement hydraulique, lesdits moyens d'actionnement hydraulique comprenant au moins une connexion de commande hydraulique (31), en communication avec la deuxième connexion de l'actionneur hydraulique, les moyens d'actionnement hydraulique étant conçus pour assurer que, lorsqu'une première pression hydraulique est présente à la deuxième connexion - ladite première pression hydraulique étant la conséquence d'une connexion formée entre la deuxième connexion et l'orifice à pression - la première connexion est reliée au réservoir, et que lorsqu'une deuxième pression hydraulique est présente à la deuxième connexion - la deuxième pression hydraulique étant la conséquence d'une connexion établie entre la deuxième connexion et le réservoir - la première connexion soit reliée à l'orifice à pression de la pompe.

2. Dispositif d'actionnement hydraulique selon la revendication 1, dans lequel le premier ensemble de soupape de commande (18), comprend un élément de commutation (23), ledit élément de commutation pouvant être déplacé entre une position primaire et une position secondaire, l'élément de commutation ayant une surface active, sur laquelle, pendant le fonctionnement, la pression hydraulique, venant de la deuxième tuyauterie de liaison, agit via la tuyauterie de commande hydraulique

lique (31),

et dans lequel le premier ensemble de soupape de commande comprend des moyens de restauration (20), conçus pour délivrer une force à l'élément de commutation, de telle manière que l'équilibre entre la force délivrée par les moyens de restauration et la force délivrée par la pression hydraulique sur la surface active de l'élément de commutation détermine si l'élément de commutation est à la position primaire ou à la position secondaire.

3. Dispositif d'actionnement hydraulique selon la revendication 2, dans lequel les moyens de restauration comprennent un ressort.
4. Dispositif d'actionnement hydraulique selon l'une des revendications précédentes, dans lequel l'actionneur comprend une tige de piston (3), dont une extrémité est fixée sur le piston, et dans lequel la première chambre de travail (6) est placée du même côté du piston que la tige de piston.
5. Dispositif d'actionnement hydraulique selon l'une des revendications précédentes, dans lequel le premier ensemble de soupape de commande (18) comprend un élément de commutation déplaçable, ainsi qu'un premier siège (21) et un deuxième siège (22) pour l'élément de commutation (23), l'élément de commutation, lorsqu'il se trouve dans le premier siège, reliant la première connexion au réservoir et, lorsqu'il se trouve dans le deuxième siège, reliant la première connexion à l'orifice à pression, et dans lequel, les moyens d'actionnement hydraulique comprennent également :
 - un cylindre de commande (33) ayant un piston de commande (34) et une connexion primaire (36), ladite connexion primaire étant connectée à la connexion de commande hydraulique (31) ;
 - un élément d'actionnement (35), conçu pour être entraîné par le piston de commande, afin d'actionner l'élément de commutation en fonction de la position du piston de commande.
6. Dispositif d'actionnement hydraulique selon la revendication 5, dans lequel l'élément de commutation (23) est une bille.

7. Dispositif d'actionnement hydraulique selon l'une des revendications 5 ou 6, dans lequel l'élément d'actionnement (35) est une tige de piston connectée au piston de commande.
8. Dispositif d'actionnement hydraulique selon la revendication 1, dans lequel le premier ensemble de soupape de commande (18) comprend une première soupape (40) et une deuxième soupape (45), et dans lequel

les moyens d'actionnement hydraulique (35) comprennent une première unité de commande pour actionner la première soupape et une deuxième unité de commande pour actionner la deuxième soupape, la première soupape ayant un premier orifice primaire menant à la première tuyauterie de connexion et un premier orifice secondaire menant au réservoir, et la deuxième soupape ayant un deuxième orifice primaire menant à la première tuyauterie de connexion et un deuxième orifice secondaire menant à l'orifice à pression,

dans lequel, lorsqu'une première pression hydraulique prévaut dans la deuxième tuyauterie de connexion, la première soupape (40) est ouverte et la deuxième soupape (45) est fermée, de manière que la première connexion de l'actionneur hydraulique soit en communication avec le réservoir, et dans lequel, lorsqu'une deuxième pression hydraulique prévaut dans la deuxième tuyauterie de connexion, la première soupape (40) soit fermée et la deuxième soupape (45) soit ouverte, de manière que la première connexion de l'actionneur hydraulique soit en communication avec l'orifice à pression.

9. Dispositif d'actionnement hydraulique selon la revendication 8, dans lequel à la fois la première soupape et la deuxième soupape sont des clapets anti-retour.

10. Dispositif d'actionnement hydraulique selon la revendication 8, dans lequel la première soupape comprend un premier élément de commutation (23a) et la deuxième soupape comprend un deuxième élément de commutation (23b), dans lequel les moyens d'actionnement hydraulique comprennent une première unité de commande pour actionner la première soupape, et une deuxième unité de commande pour actionner la deuxième soupape, au moins l'une des unités de commande comprenant :

- un cylindre de commande ayant un piston de commande et une connexion primaire,
- un élément d'actionnement conçu pour être entraîné par le piston de commande, pour actionner l'élément de commutation de la soupape respective, en fonction de la position du piston de commande,

et dans lequel, une connexion de commande hydraulique forme une connexion entre la connexion primaire et la deuxième tuyauterie de connexion.

11. Dispositif d'actionnement hydraulique selon la revendication 10, dans lequel l'élément de commutation est une bille.

12. Dispositif d'actionnement hydraulique selon l'une des revendications 10 ou 11, dans lequel l'élément d'actionnement est une tige de piston, connectée au piston de commande.

13. Véhicule, muni d'un composant mobile, en particulier un élément de fermeture pour fermer une ouverture dans une carrosserie de véhicule, telle que, par exemple, un toit mobile, un toit pliable ou un toit dur rétractable, muni d'un dispositif d'actionnement hydraulique selon l'une des revendications précédentes.

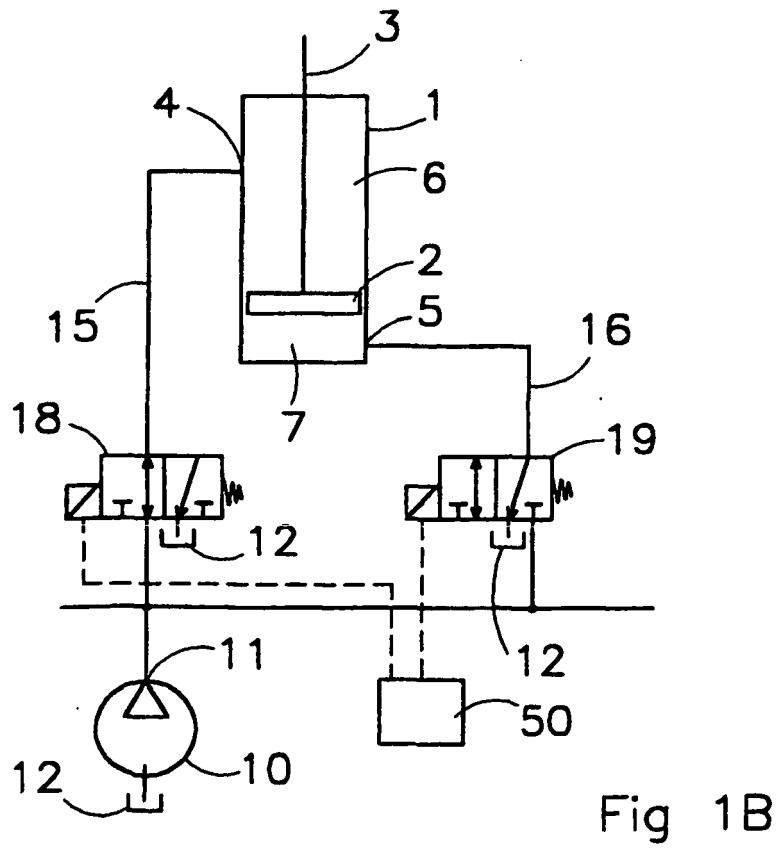
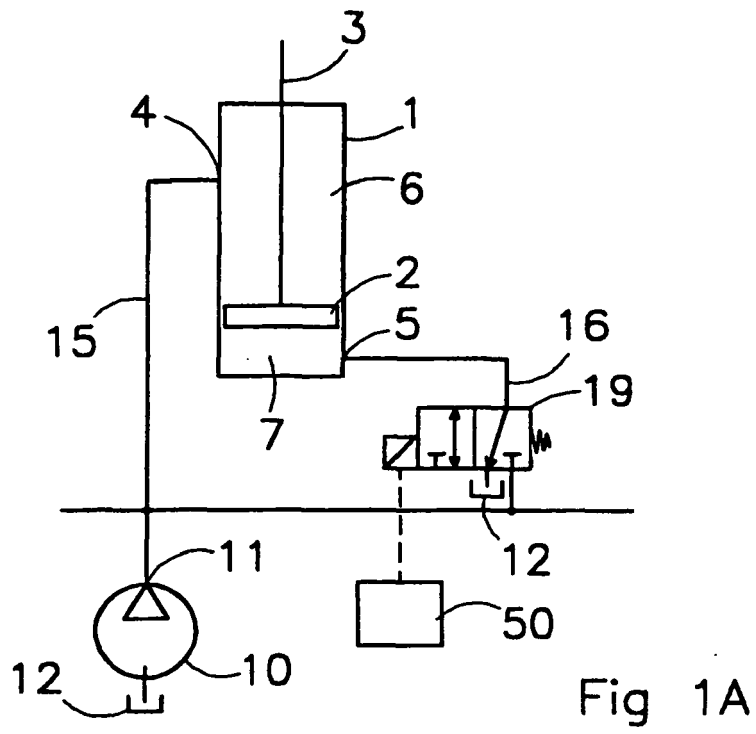

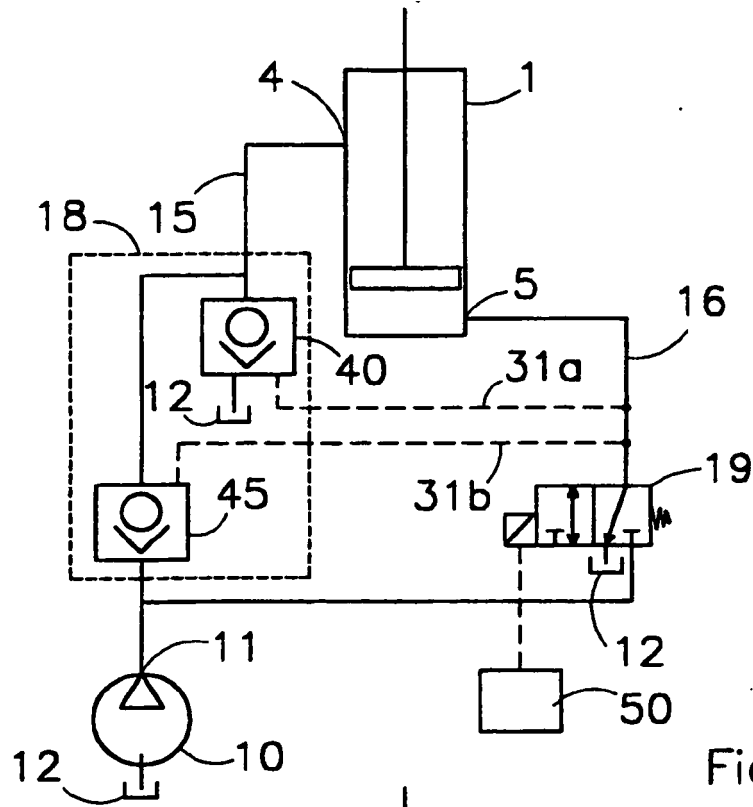

Fig 4

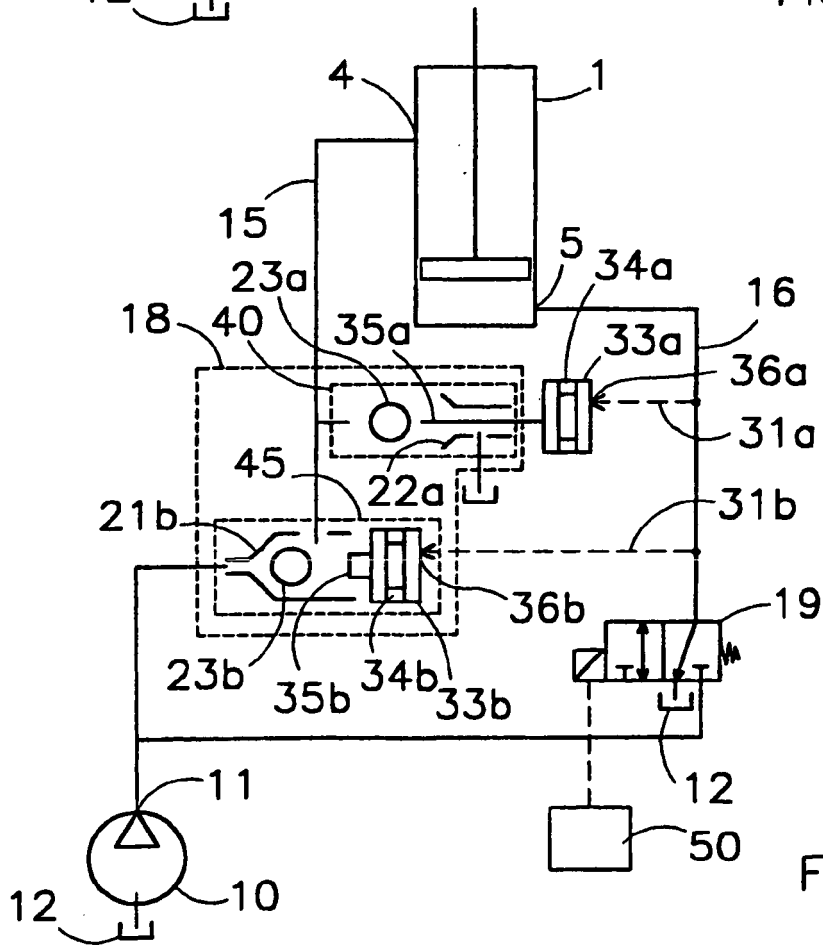

Fig 5

REFERENCES CITED IN THE DESCRIPTION

This list of references cited by the applicant is for the reader's convenience only. It does not form part of the European patent document. Even though great care has been taken in compiling the references, errors or omissions cannot be excluded and the EPO disclaims all liability in this regard.

Patent documents cited in the description

- EP 1052127 A [0004]
- DE 10253340 A1 [0005]