



(12) EUROPEAN PATENT APPLICATION

(43) Date of publication:  
25.01.2006 Bulletin 2006/04

(51) Int Cl.:  
E01F 15/08 (2006.01)

(21) Application number: 05076582.5

(22) Date of filing: 11.07.2005

(84) Designated Contracting States:  
AT BE BG CH CY CZ DE DK EE ES FI FR GB GR  
HU IE IS IT LI LT LU LV MC NL PL PT RO SE SI  
SK TR  
Designated Extension States:  
AL BA HR MK YU

(72) Inventors:  
• Monteleone, Mauro  
10090 Castiglione TO (IT)  
• Burzi, Marcello  
12059 La Morra CN (IT)

(30) Priority: 13.07.2004 IT RM20040348

(74) Representative: Fiammenghi-Domenighetti,  
Delfina  
Fiammenghi-Fiammenghi,  
Via San Gottardo 15  
6900 Lugano (CH)

(71) Applicants:  
• Monteleone, Mauro  
10090 Castiglione TO (IT)  
• Burzi, Marcello  
12059 La Morra CN (IT)

(54) New jersey motorway crash barrier element with continuous uprights

(57) A New Jersey crash barrier element (1) is described, said element comprising a support base (2) fixed to the ground (T) by means of anchoring means, plus substantially vertical posts (4) connected to the said support base (2) and having, fixed thereon, reinforcing ribs (5i, 5e) and a surrounding casing (6), on the top ends of the said posts (4) there being mounted extension members (7) which support a handrail (8) arranged parallel to the ground (T). In the element (1) of the invention each of the said posts (4) and the respective extension member (7) form a continuous upright (9), at least some (5i) of the said reinforcing ribs (5i, 5e) and the said handrail (8) being profiled parts which have holes (8f, 5f) which are passed through by the said strut (9), the cross-section of which has a shape complementing them.

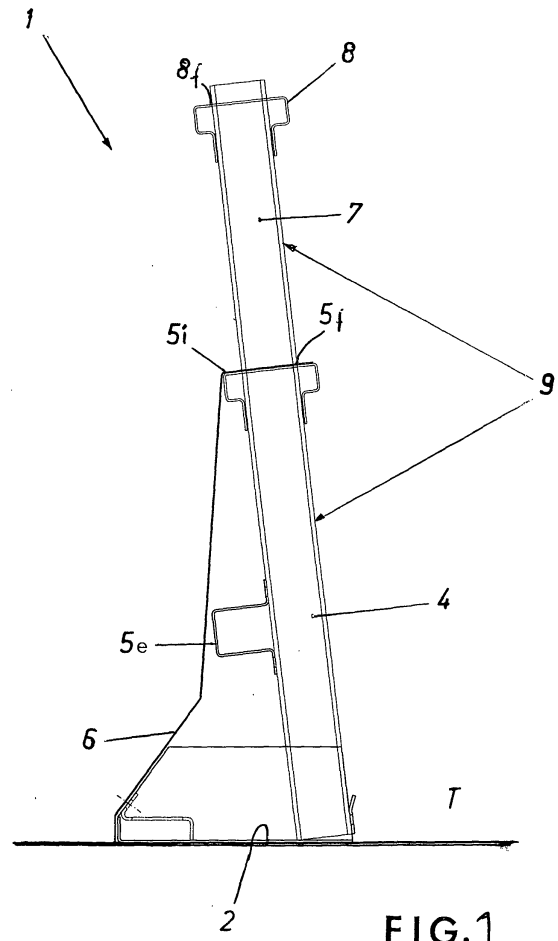

**Description**

**[0001]** The present invention relates to the technological sector of the elements which, arranged in succession as an extension of each other, form a motorway crash barrier of the so-called New Jersey type.

**[0002]** These crash barriers have the function of absorbing as gradually as possible the kinetic energy which is transmitted to them following the impact caused by a vehicle striking them, and essentially the elements which form them comprise a support base fixed to the ground, plus substantially vertical posts connected to it and provided with reinforcing ribs and a surrounding casing. Extension members are mounted on the top ends of the said posts and support a handrail parallel to the ground.

**[0003]** In the embodiments known according to the state of the art, these extension members are separate parts fixed to the barrier on the top ends of the above-mentioned posts. Two examples consist of the New Jersey crash barrier elements described in the patent applications EP 01201092.6 and EP 0575705. This solution, however, has drawbacks mainly arising from the fact that an impact which has its point of contact along the handrail mentioned above is borne exclusively by the extension members which are deformed and/or detached from the barrier element without being able to transmit some of the stresses to the element itself and in particular to its posts which, as is known, form the parts most able to absorb and cushion the said stresses.

**[0004]** The solution described above, moreover, involves considerable costs both as regards the construction of the separate extension members and as regards the mounting work required to fit them onto the barrier.

**[0005]** The inventors of the subject of the present invention have provided an innovative solution which is able to overcome all the drawbacks mentioned above, devising an element of a New Jersey crash barrier in which each post and the associated extension member form one piece and, in particular, a continuous upright preferably designed in the form of a section, and the other members (handrail, reinforcing ribs, etc) are passed through by this upright by means of holes with a complementary shape formed in them.

**[0006]** The subject of the present invention therefore relates to an element of a New Jersey crash barrier in accordance with that described in the accompanying Claim 1.

**[0007]** A more detailed description of two preferred embodiments of the barrier element according to the invention will now be described, with reference also to the accompanying drawings in which:

Fig. 1 is a cross-section of a first example of embodiment suitable for a lateral barrier, through one of the said uprights;

Fig. 2 is a cross-section of a second example of embodiment suitable for a central barrier used as a central reservation, through one of the abovementioned

uprights.

**[0008]** If we consider Fig. 1, this shows how, in an element 1 of a New Jersey lateral crash barrier according to the invention, each post 4 connected to the support base 2 forms, together with the associated extension member 7 joined to its top end, a continuous upright 9.

**[0009]** In the case in question this upright 9 is a simple extruded section and passes through both one 5i of the reinforcing ribs 5i, 5e and the said handrail 8 which is parallel to the ground T, via two holes 5f, 8f formed in them and having a shape complementing that of the cross-section of the abovementioned strut 9, and the surrounding casing 6 is mounted on the outside of the latter.

**[0010]** It must be pointed out that the handrail 8 must be further fixed to the strut 9, preferably by means of bolting and/or welding (this detail is not shown in the drawings).

**[0011]** Fig. 2 shows a second example of embodiment of a New Jersey barrier element 11 according to the invention, suitable for use as a central reservation. Apart from the inclination of the various parts and the different form of the casing 16, arranged symmetrically on both sides of the element 11, this example is also constructionally entirely similar to that described previously.

**[0012]** In this case also, in fact, each post 14 forms with the respective extension member 17 a single continuous part, i.e. a strut 19 which is fixed to the support base 12 and passes through one of the reinforcing ribs 15i and the handrail 18 via complementary holes 15f, 18f formed in them, and all the observations made in respect of the previous example are also applicable here.

**[0013]** In both the examples described above an element 1, 11 of a New Jersey crash barrier has been obtained, this barrier being cheaper to produce and having functional features which are better than those provided according to the state of the art, such that the stresses generated by the impact of a motor vehicle are better distributed over the parts which form the barrier element itself.

**[0014]** The predefined object of the inventors has thus been obtained.

**Claims**

1. New Jersey crash barrier element (1, 11), comprising a support base (2, 12) fixed to the ground (T) by means of anchoring means, plus substantially vertical posts (4, 14) connected to the said support base (2, 12) and having, fixed thereon, reinforcing ribs (5i, 5e, 15i, 15e) and a surrounding casing (6, 16), on the top ends of the said posts (4, 14) there being mounted extension members (7, 17) which support a handrail (8, 18) arranged parallel to the ground (T), **characterized in that** each of the said posts (4, 14) and the respective extension member (7, 17) form a continuous upright (9, 19), at least some (5i, 15i) of

the said reinforcing ribs (5i, 5e, 15i, 15e) and the said handrail (8, 18) being profiled parts which have holes (8f, 18f, 5f, 15f) which are passed through by the said strut (9, 10), the cross-section of which has a shape complementing them.

5

2. Barrier element according to Claim 1, in which the said handrail (8, 18) and the ribs (5i, 5e, 15i, 15e) are fixed by means of bolting and/or welding to the continuous struts (9, 19) of the said element.

10

15

20

25

30

35

40

45

50

55

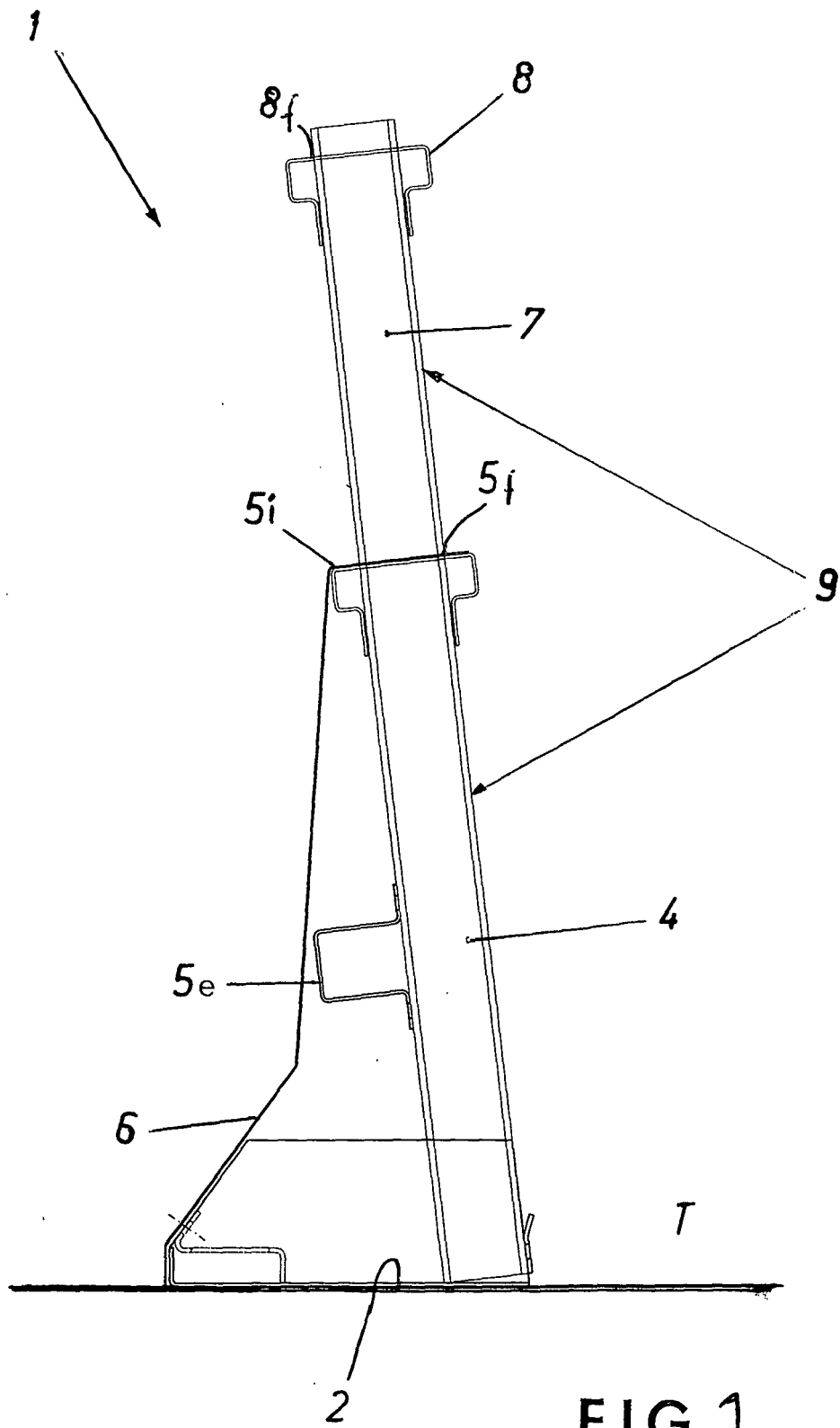

FIG.1

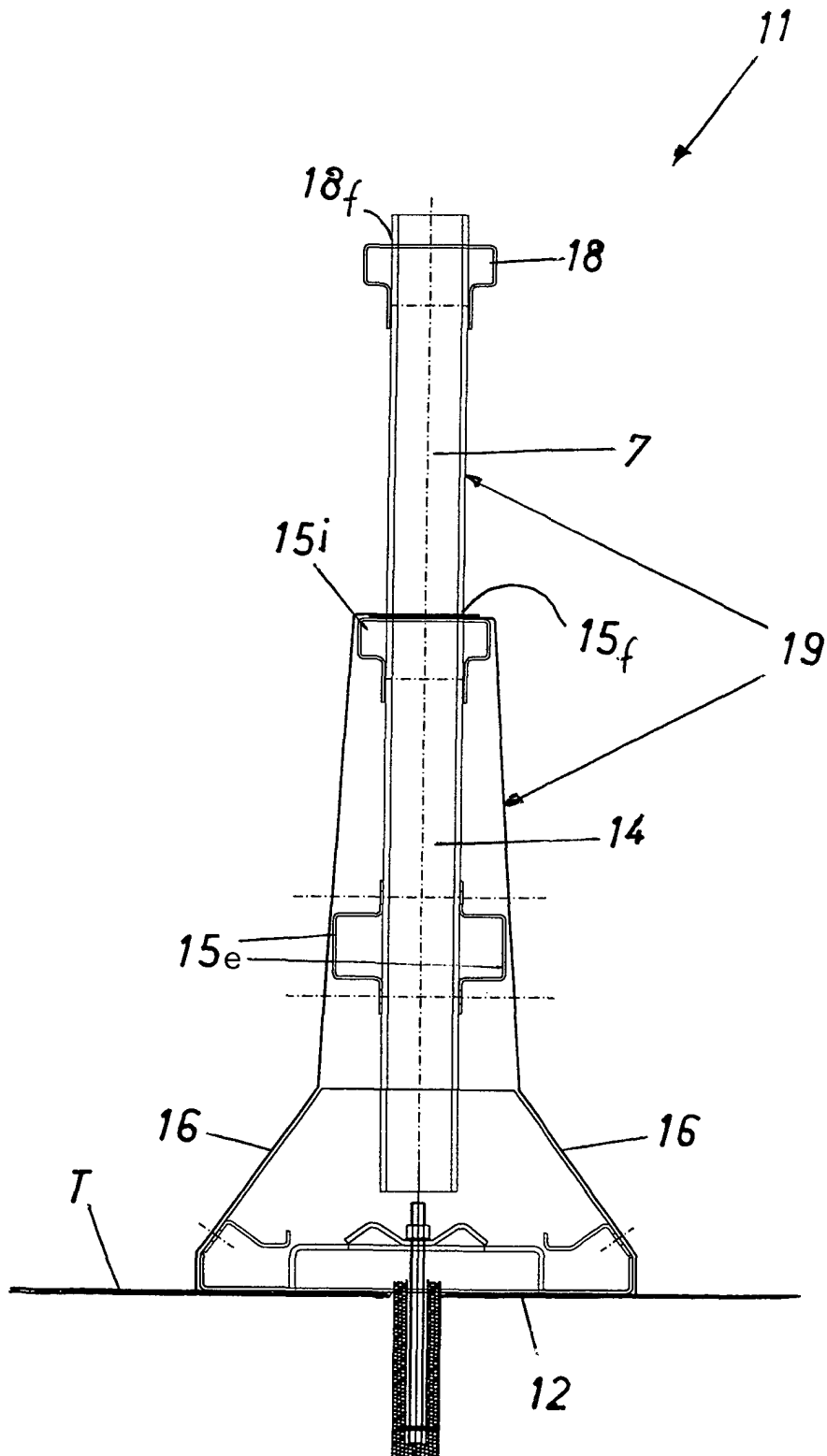

FIG. 2



DOCUMENTS CONSIDERED TO BE RELEVANT			
Category	Citation of document with indication, where appropriate, of relevant passages	Relevant to claim	CLASSIFICATION OF THE APPLICATION (Int.Cl.7)
Y	DE 38 16 528 A1 (SPIG SCHUTZPLANKEN-PRODUKTIONS-GESELLSCHAFT MBH & CO KG, 6612 SCHMELZ,) 23 March 1989 (1989-03-23) * column 8, line 46 - column 9, line 37; figures 1,7 *	1,2	E01F15/08
Y	DE 43 20 296 A1 (SPS SCHUTZPLANKEN GMBH, 63743 ASCHAFFENBURG, DE) 22 December 1994 (1994-12-22) * column 3, lines 49-53; figures 1,4 *	1,2	
D,A	EP 0 575 705 A (SISTEMA S.A.S. DI SERAFIN LUIGI & C; SISTEMA S.R.L) 29 December 1993 (1993-12-29)		
			TECHNICAL FIELDS SEARCHED (Int.Cl.7)
			E01F E01D
The present search report has been drawn up for all claims			
Place of search		Date of completion of the search	Examiner
Munich		27 October 2005	Flores Hokkanen, P
CATEGORY OF CITED DOCUMENTS		T : theory or principle underlying the invention E : earlier patent document, but published on, or after the filing date D : document cited in the application L : document cited for other reasons ..... & : member of the same patent family, corresponding document	
X : particularly relevant if taken alone Y : particularly relevant if combined with another document of the same category A : technological background O : non-written disclosure P : intermediate document			

2  
EPO FORM 1503 03.82 (P04C01)

**ANNEX TO THE EUROPEAN SEARCH REPORT  
ON EUROPEAN PATENT APPLICATION NO.**

EP 05 07 6582

This annex lists the patent family members relating to the patent documents cited in the above-mentioned European search report. The members are as contained in the European Patent Office EDP file on The European Patent Office is in no way liable for these particulars which are merely given for the purpose of information.

27-10-2005

Patent document cited in search report	Publication date	Patent family member(s)	Publication date
DE 3816528	A1	23-03-1989	DE 3827030 A1 06-04-1989
DE 4320296	A1	22-12-1994	NONE
EP 0575705	A	29-12-1993	AT 147814 T 15-02-1997
			CZ 9300552 A3 17-11-1993
			DE 69307403 D1 27-02-1997
			DE 69307403 T2 10-07-1997
			ES 2096123 T3 01-03-1997
			GR 3022485 T3 31-05-1997
			HU 63891 A2 28-10-1993
			IT UD920013 U1 14-10-1993
			SK 34793 A3 10-11-1993