



(12) **EUROPEAN PATENT APPLICATION**

(43) Date of publication:  
**17.05.2006 Bulletin 2006/20**

(51) Int Cl.:  
**H01F 27/32<sup>(2006.01)</sup> H01F 41/10<sup>(2006.01)</sup>**

(21) Application number: **04425853.1**

(22) Date of filing: **15.11.2004**

(84) Designated Contracting States:  
**AT BE BG CH CY CZ DE DK EE ES FI FR GB GR  
HU IE IS IT LI LU MC NL PL PT RO SE SI SK TR**  
Designated Extension States:  
**AL HR LT LV MK YU**

(72) Inventor: **Bordin, Luca**  
**31010 Maser (IT)**

(74) Representative: **Giustini, Delio et al**  
**Siemens AG**  
**CT IPS AM**  
**Postfach 22 16 34**  
**80506 München (DE)**

(71) Applicants:  
• **Patent-Treuhand-Gesellschaft für elektrische  
Glühlampen mbH**  
**81543 München (DE)**  
• **OSRAM S.P.A. - SOCIETA' RIUNITE OSRAM**  
**EDISON CLERICI**  
**20144 Milano (IT)**  
Designated Contracting States:  
**IT**

(54) **A transformer and a related method of assembly**

(57) A transformer (1) includes a bobbin (2) defining primary (21) and secondary (22) winding chambers, a core (4) mounted on said bobbin, as well as primary (31) and a secondary (32) windings wound in the primary (21) and secondary (22) winding chambers. The core (4) is an EFD/EFF ferrite core, and the bobbin (2) includes a

cover cap (52) for the secondary winding chamber (22). The bobbin (2) including the cover cap (52) are configured to provide reinforced insulation of the secondary winding (32) with respect to the primary winding (31) and the core (4) to render the transformer (1) SELV-compliant with EN 61347, and compliant with UL 1310.

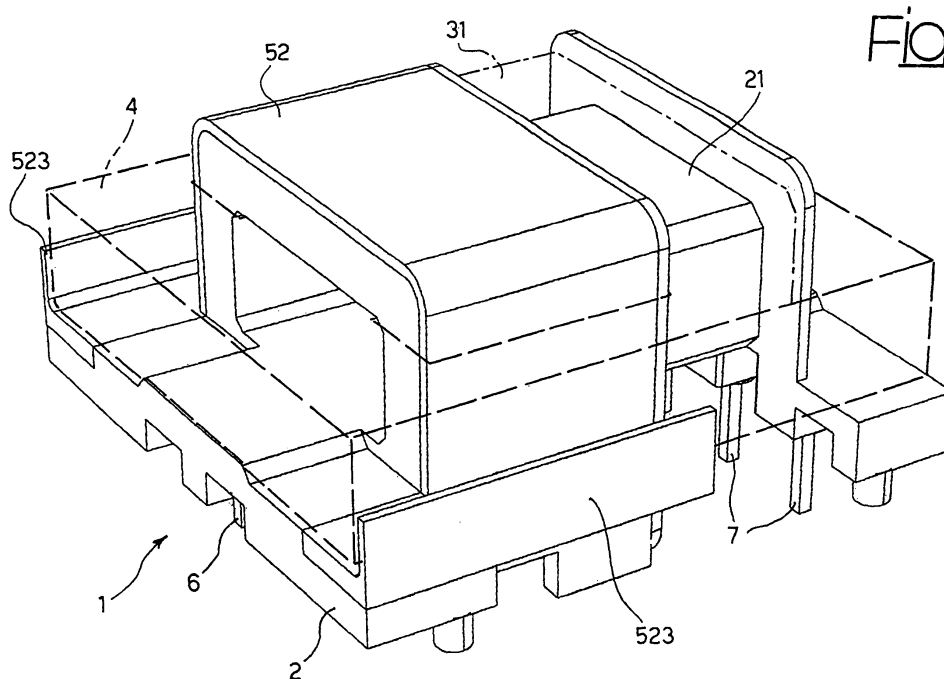

Fig. 1

**Description**Field of the invention

**[0001]** The present invention relates to (electrical) transformers.

Description of the related art

**[0002]** Transformers are used in several areas e.g. in power supply units for halogen lamps, wherein an input line voltage (e. g. the typical 220-240 volt mains voltage of most European countries, while 100 - 120 volts are typical values for many American countries) is transformed into an output voltage of 6, 12 or 24 volts. Transformers are also frequently used as output isolating transformers in electronic converters for halogen lamps to produce a 12 volt output voltage.

**[0003]** So-called "toroidal" transformers are frequently used for the applications mentioned in the foregoing. In these prior art transformers, the walls of the bobbin must have a thickness of about 1mm for working voltages of up to 250 volts to fulfil the requirement SELV (Safety Extra Low Voltage) as stated in EN 61347 (General and Safety requirements) .

**[0004]** Thick copper wires are also currently used for the secondary windings. These wires exhibit a sufficient rigidity to permit automatic placement during assembly of the transformers. The ends of the primary winding are conversely soldered to associated pins. This is particularly the case for electronic transformers for halogen lamps. These are in fact step-down transformers, i.e. transformers where the voltage at the secondary winding is lower than the voltage at the primary winding, thus leading to a higher current at the secondary winding with respect to the current at the primary winding. This leads to thinner wires at the primary that must be soldered to the pins in order to have a sufficient degree of rigidity. A bobbin having quite a simple structure is typically selected, with the main purposes of permitting fixing the pins and the secondary wires and supporting the magnetic part of the transformer. In some cases this inevitably involves the need of using a triple insulated wire for the secondary winding with the additional provision of a layer of insulating tape. In order to meet the requirements of standards such as EN 61347 regarding SELV, since the secondary winding is external, all components related to the primary must be placed at 3mm from the secondary winding if they are not isolated, very close to it if they are basic isolated. In the remainder of cases, all components related to the primary side must be placed at a distance of at least 3mm from the winding, if they have a basic insulation and at least 6mm if such an insulation is not provided.

**[0005]** Additionally, these transformers are critical from the point of view of electromagnetic compatibility (EMC) and require complicated thermal protection, all these being factors that militate against the cost-effec-

tiveness of the final solution.

**[0006]** Additional critical factors that need to be taken into account are related to:

- mounting the transformer on a very small substrate (such as narrow printed circuit board or PCB),
- placing the transformer very close to other components arranged on the same board, such as e.g. components referred to the primary side of the transformer, provided with or without a basic insulation and placed at a distance of less than 1mm, as well as letting the conductive copper tracks connected to the secondary winding run on the so-called component side of the board, namely the side of the board onto which the components are mounted,
- reducing the height of the final product, and
- permitting a fully automated assembly of the transformer.

**[0007]** For instance, typical requirements to be met in present-day applications are a maximum height of the transformer from the substrate less than 14.5mm, a power handling capacity of 75 Watts in nominal working conditions (European mains voltages) and the ability of fixing the ends of the wires of the windings in order to avoid problems likely to arise during the assembly phase of the transformer in production.

Object and summary of the invention

**[0008]** While a good deal of these problems and needs are already tackled by the transformer disclosed in EP-B-0 793 243, after which the preamble of claim 1 was patterned, the need is still felt for further improved arrangements.

**[0009]** The object of the present invention is thus to provide a transformer adapted to fully satisfactorily meet the requirements set forth in the foregoing.

**[0010]** According to the present invention, that object is achieved by means of a transformer having the features set forth in the claims that follow. The invention also relates to a corresponding method of assembly. The claims form an integral part of the disclosure of the invention provided herein.

**[0011]** A particularly preferred embodiment of the invention uses an EFD (or EFF) core in the place of a ferrite core. An EFD core is a sort of E core, which is however "flatter" than an E core, the effective area being equal. In that way a power of the order of 75 Watts can be delivered in nominal European halotronic working conditions with the maximum height from the substrate of less than 14.5mm.

**[0012]** A particularly preferred embodiment of the invention provides for the presence of a bobbin around this kind of core that permits the whole transformer component to be in compliance with SELV (Safety Extra Low Voltage) insulation requirements.

**[0013]** The components referred to the primary side

can be placed very close to transformer and the secondary tracks can run on the component side of the board since the secondary winding is reinforced insulated (following EN 61347) from the core, this being the more external conductive part of the component.

**[0014]** Preferably, the transformer of the invention includes two winding chambers that are separated and placed close to each other. Still preferably, the structure is an asymmetric one, namely insulation is provided at one chamber (usually the secondary winding chamber), in the form of reinforced insulation, contrary to the arrangement of EP-B-0793 243, where double insulation is used. Insulation is preferably provided also outside the core (e.g. via extensions of a cover cap associated with the bobbin), and not just within.

**[0015]** A transformer as described herein can be automatically mounted (i.e. located on a substrate such as a PCB) even the secondary wire is a Litz wire, which is rather flexible. The end terminals of the secondary windings are preferably soldered together with the pins, thus giving rise to thick pins that are stable and can be fixed as a normal pin. The operation of soldering the winding wire to the pins is facilitated by the preferred provision of apertures in the form of e.g. notches (dead-holes) in the transformers casing. These notches retain the wire securely in place in possible cooperation with beak formations provided in the casing itself.

#### Brief description of the annexed drawings

**[0016]** The invention will now be described, by way of example only, by referring to the enclosed figures of drawing, wherein:

- figure 1 is general perspective view of a transformer of the type described herein,
- figure 2 is a lateral perspective view of a transformer as described herein with one of the elements included in the transformer removed for clarity of illustration,
- figure 3 is a front perspective view of the transformer shown in figure 2, with again the same element shown removed for the sake of clarity, and
- figure 4 is a bottom perspective view of the bobbin of the transformer described herein.

#### Detailed description of an exemplary embodiment of the invention

**[0017]** In the drawings, reference 1 designates as a whole a transformer adapted for use, e.g. in connection with the halogen lamps. Such a transformer is usually intended to operate in a frequency range higher than the mains frequency and includes the basic following elements:

- a bobbin, typically comprised of a moulded insulating material such as e.g. polyethylene, and including pri-

mary and secondary winding bodies defining respective primary and secondary winding chambers 21 and 22,

- primary and secondary windings 31 and 32 wound around the primary and secondary winding bodies in the primary and secondary winding chambers 21 and 22, respectively; and
- a ferromagnetic core arranged over the bobbin 2 in such a way to cooperate with the primary and secondary windings 31 and 32 to create the mutual impedance arrangement underlying operation of the transformer.

**[0018]** The two winding chambers 21 and 22 are thus separated and placed close to each other, i.e. side-by-side.

**[0019]** Throughout figures 1 to 3, the windings 31, and 32 as well as the core 4 are schematically shown in dashed/chain lines only in order to facilitate clearer representation and understanding of the features of the bobbin 2. In figure 4 only the bobbin 2 is shown.

**[0020]** The transformer 1 described herein is particularly adapted to operate with cores of the EFD type (sometimes referred to also as EFF cores by some manufacturers in the Far East).

**[0021]** A particularly preferred embodiment of the arrangement described herein provides for the core 4 to be ferrite core of the EFD 25 type. This core type slightly differs from standard E-type cores due to having a lowered profile while maintaining the same effective area ( $A_e$ ). Resorting to such a core is advantageous in that it leads to a transformer 1 having a lower thickness (height) overall while maintaining a good power handling capacity.

**[0022]** The arrangement described herein adopts such a core type while ensuring full compliance with insulation requirements as dictated by standards such as EN 61347 concerning the so-called SELV (Safety Extra Low Voltage) insulation requirement.

**[0023]** Essentially, the arrangement described herein provides such a level of insulation by providing reinforced insulation of the secondary winding 32 with respect to the primary winding 31 and the ferrite core 4. In that way, any electronic components related to the primary winding 31 can be mounted very close to the ferrite core 4 (this fact can be best appreciated in figure 2). As used herein, "very close" means distances lower than 1mm or even just the distance enough to avoid that such components may come in direct contact with each other (that is "touch" each other).

**[0024]** By way of direct comparison, it will be appreciated that the arrangement described herein differs from the arrangement disclosed in EP-B-0 793 243 i.a. in that such prior art arrangement involves a double insulation between the primary and secondary windings. This is provided by basic insulation between the ferrite core and the primary winding plus supplementary insulation between the ferrite core and the secondary winding.

**[0025]** In the arrangement described herein, the reinforced level of insulation (SELV) is achieved with an insulation thickness of at least 1mm between the primary winding 31 and the secondary winding 32 and between the secondary winding 32 and the ferrite core. Additionally, an air "creepage" and a given clearance are provided between the primary winding 31 and the secondary winding 32, on the one side, and between the secondary winding 32 and the ferrite core 4, on the other hand.

**[0026]** A value for such clearance is at least 6mm, while increased values of 6.4mm may be taken into account when complying with the American norm UL 1310 (Standard for Safety for Class 2 Power Units). This norm is claimed by the American Subject UL 879A in order to cover LED (light emitting diodes) kits for field installations, where the transformer 1 can be used.

**[0027]** Specifically, a protective cover cap of an electrically insulating material 52 is provided and adapted to be associated with the secondary winding chamber. The cap 52 is typically comprised of the same electrically insulating material that comprises the other parts of the bobbin. The cap 52 will thus be considered in all respects as a part of the bobbin 2 of the transformer.

**[0028]** The thickness for all the walls surrounding the secondary chamber wherein the secondary winding 32 is wound is thus selected as having a minimum thickness of no less than 1mm, while 1.5mm is a preferred thickness for the lateral walls of the chambers due to a presence of labyrinths as better described in the following. In the exemplary embodiment shown herein, the cover cap 52 has approximately an "omega" or "mesa" shape overall (this can best be appreciated in the front view of figure 3) and the lateral walls of the secondary winding chamber are thus defined by the lateral walls 520 of the cap 52.

**[0029]** The thickness of the walls between the primary and secondary windings 31, 32 which walls are designated 320 in figure 2 is typically 0.5mm.

**[0030]** In order to ensure the desired creepage of 6-6.4mm a labyrinth is created at both ends of the secondary winding 32 by creating interpenetrating walls portions of those part of the bobbin structure situated at the ends of the secondary winding chamber and complementary wall formations provided in the cap 52.

**[0031]** Specifically, a first set of interpenetrating walls is created by causing the wall 320 between the primary and secondary windings 31, and 32 to be provided with a groove 321 adapted to interpenetratingly cooperate with a protruding wall 521 provided at the inner (i.e. proximal) side of the cap 52. The presence of the wall 521 and its interpenetrating relationship with the groove 321 provided in the wall 320 are best appreciated in the plan view of figure 4.

**[0032]** A thoroughly similar labyrinth arrangement is provided at the opposite, outer (i.e. distal) end of the secondary winding 32 by providing an end wall 322 having a central notch or groove 323 adapted to interpenetratingly cooperate with another wall 522 protruding from the internal surface of the cap 52 as best appreciated in figure

3.

**[0033]** The labyrinth arrangement associated with the central wall 320 has a typical nominal length of about 6.7mm, which is enough to provide an effective creepage distance between the primary and secondary windings 31, 32 in excess of 6.4mm.

**[0034]** The labyrinth arrangement associated with the wall 322 is usually arranged in order to provide a nominal creepage distance of about 6.5mm.

**[0035]** Another factor ensuring the desired level of insulation is given by controlling the distance between the core 4 and the connection pins 6 associated with the secondary winding. Such pins are usually located protruding from the lower surface of the bobbin 2. These can be provided by resorting to any standard techniques known for that purpose, e.g. in the form of metal pins inserted in the plastic mould for the bobbin. Alternatively, the pins 6 can be provided in the form of integral parts of the bobbin plastic mould over which the ends of the wire of the secondary winding are wound and soldered. Such an arrangement is described in EP 04425772.3 filed on 13 October 2004 in the name of the same Applicants.

**[0036]** A similar arrangement can be resorted to for the connection pins associated with the primary winding 21. In the exemplary embodiment shown herein, the primary pins, designated 7 as a whole, are to the number of four while the secondary 6 are to the number of two. This is simply dictated by the fact the primary winding 22 may in fact be arranged to include different tap/contact points in order to render the transformer 1 adapted to operate with different input voltages while providing the same output voltage. If there is no need for that, the placement of the primary pins can be chosen at convenience.

**[0037]** Turning again to the point of the distance between the secondary pins 6 and the core 4, a typical value in the arrangement shown is of at least 7.2mm, which appears to be thoroughly satisfactory for the application contemplated and ensuring SELV insulation.

**[0038]** Another factor that plays a role in determining the level insulation of the transformer described herein is given by the path between the secondary pins 6 (and the secondary winding 32) and the ferrite core 4 within the transformer.

**[0039]** This again includes a labyrinth formation essentially determined by two lateral L-shaped extensions 524 that extends at both sides of the cap 52. These extensions are covered by the notch 324 when the cap is inserted in its position. The length of the path through the labyrinth that is established between the secondary winding and the ferrite core or between a possible secondary track on the component side of the board and the ferrite core is far more than 6.4mm.

**[0040]** From the view of Figure 2 it will be further appreciated that the vertical height of the cover cap 52 has a maximum value in correspondence with the central wall 320 and gradually decreases towards the distal end of the cap 52 to reach a minimum value in correspondence

with the end wall 322, thus avoiding to any obtrusive affect with respect to the secondary pins 6.

**[0041]** The possible expected presence of secondary connection tracks on the component side of the PCB onto which the transformer 1 is mounted is to be taken into account in order to ensure full SELV compliance of the transformer described herein for any possible application.

**[0042]** The cap 52 is designed in such a way to take up the overall "omega" or "mesa" shape. As best appreciated in the views of Figures 1 and 2, the extensions ("beaks") 523 do not extend just in correspondence with the cap length 52 but also extend in a longitudinal direction of the transformer to envelope or embrace the core 4 for the complete extension thereof, thus supporting the core at its "secondary" end.

**[0043]** In that way a air path between the possible secondary track and the ferrite core largely in excess of 6.4mm can be easily obtained e.g. by selectively varying the heights of the vertical parts of the lateral protrusions 523. It is easily possible to let the beaks 523 become two walls that encircle the entire outer legs of the ferrite core in order to shield the ferrite from components referred to the secondary side placed in the proximity of the transformer. In this way the extensions 523 will have a general C-shape that embrace the outer leg of the core 4.

**[0044]** As regards connecting the ends of the windings 31, 32 to the respective set of pins 6, 7 this description will implicitly assume that the case considered is a step-down application. In step-down applications the wire of the primary winding 31 is relatively thin and thus flexible while adapted to retain a given shape. For such a wire the arrangement described preferably resorts to standard arrangement e.g. by winding and soldering the wire to the pins 7.

**[0045]** In step-up applications (i.e. those applications where the voltage at the secondary winding is higher than the voltage at the primary winding, thus leading to a lower current at the secondary winding with respect to the current at the primary winding), what has been stated in the foregoing will generally apply to the same transformer when considering the secondary winding 32 as a primary winding and vice versa for the winding 31.

**[0046]** In typical step-down applications, the wire of the secondary winding 32 (and this will apply to the wire of the primary winding in the case of step-up applications) can be of three types: a copper wire covered by an insulating enamel, a Litz wire, or a conductor comprised of a braid of very thin wires.

**[0047]** A copper wire covered by an enamel is per se rather rigid, not unlike a pin by itself, whereby the respective ends can be extended through the base portion of the bobbin 2 and play the role of the pins 6 themselves thus permitting automated assembly of the transformer 1.

**[0048]** Conversely, a Litz wire, or - even worse - a braid of very thin wires is intrinsically non rigid, which by necessity requires it to be wound around a pin or in any case fixed onto the pin in order to create a rigid member

(pin) adapted to extend through the mounting hole in the printed circuit board. This however leads to a situation where a high current may flow through a very thin pin thus increasing the temperature of the components in that area. Directly connecting a Litz wire to the tracks/strips provided in the board may reduce the temperatures in the secondary winding of 5-10°C. This currently leads to most transformers having a Litz wire secondary winding to be assembled manually by an operator.

**[0049]** In the arrangement described herein, two apertures in the form of notches (i.e. dead-holes) 8 are provided in the bobbin in the vicinity of the secondary pins 6.

**[0050]** Preferably, the apertures 8 are directly produced during the moulding process of the bobbin 2.

**[0051]** The ends of the secondary winding 32 (schematically indicated as W and assumed to be comprised of Litz wire or a braid of thin wires) are thus passed through the notches 8 to be soldered to the pins 6. The apertures/notches 8 permit the ends W to be safely kept in a fixed position while the wire ends W are being soldered to be the pin 6 to give rise to a rather massive arrangement.

**[0052]** In this latter respect, it will be appreciated that molten solder, once brought to the usual soldering temperatures used by winding machines for connecting the end of the windings to the pins, is a highly polar liquid. It intrinsically tends to fill the interstices between the wires (as those comprising e.g. a Litz wire or a wire braid). When removed from the soldering bath the wire ends will thus be in fact compacted and made solidary with the metallic pins 6.

**[0053]** By resorting to that arrangement, a transformer 1 may be produced that is adapted to be easily assembled in an automated way. This while also benefiting from the advantages mentioned in terms of reducing the temperature at the connecting points with the PCB strips and the components located nearby.

**[0054]** Consequently, without prejudice to the underlying principles of the invention, the details and embodiments may vary with respect to what has been described and shown, by way of example only, without departing from the scope of the invention, as defined by the annexed claims.

## Claims

1. A transformer (1) including:

- a bobbin (2) defining primary (21) and secondary (22) winding chambers,
- a core (4) mounted on said bobbin, and
- primary (31) and secondary (32) windings wound in said primary (21) and secondary (22) winding chambers, respectively, wherein the bobbin (2) includes a cover cap (52) associated with said secondary winding (32),

**characterized in that:**

- said core (4) is an EFD/EFF core, and
  - said bobbin (2) including said cover cap (52) is configured to provide reinforced insulation of said secondary winding (32) with respect to said primary winding (31) and said core (4).
2. The transformer of claim 1, **characterized in that** it is SELV-compliant with EN 61347, and compliant with UL 1310.
  3. The transformer of either of claims 1 or 2, **characterized in that** said primary (21) and secondary (22) winding chambers are arranged side-by-side.
  4. The transformer of any of claims 1 to 3, **characterized in that** said cover cap (52), and thus said reinforced insulation, extends primarily over said secondary winding (32), without extending to said primary winding (31).
  5. The transformer of any of the previous claims, **characterized in that** said cover cap (52) extends over the entirety of said secondary winding (32).
  6. The transformer of any of the previous claims, **characterized in that** said cover cap (52) has lateral extensions (523) at least marginally surrounding said core (4), and possibly extending to encircle the entire outer legs of the ferrite core (4).
  7. The transformer of any of the previous claims, **characterized in that** said bobbin (2), including said cover cap (52) is comprised of an insulating material.
  8. The transformer of any of the previous claims, **characterized in that** said bobbin (2) includes a separating wall (320) having a wall thickness of at least 1mm between said primary winding (31) and said secondary winding (32) as well as separating walls (520, 22, 322) having a wall thickness of at least 1mm between said secondary winding (32) and said core.
  9. The transformer of any of the previous claims, **characterized in that** said bobbin (2) including said cover cap (52) are configured to provide an air creepage and clearance of at least 6.4mm between said primary (21) and said secondary winding (22) and between said secondary winding (22) and said core (4).
  10. The transformer of any of the previous claims, **characterized in that** said secondary winding chamber (22) is completely surrounded by walls having a thickness of at least 1mm.
  11. The transformer of any of the previous claims, **characterized in that** said cover cap (52) has an omega or mesa-like overall shape.
  12. The transformer of either of claims 1 or 11, **characterized in that** said cover cap (52) has lateral extensions (523) extending from said cover cap (52) to embrace the longitudinal legs of said EFD/EFF core (4).
  13. The transformer of claim 12, **characterized in that** said lateral extensions (523) have a general L-shape with distal portions that at least marginally cover said core (4) to create an air path between an in case secondary track (32) and said ferrite core (4) on the outside of the transformer (1).
  14. The transformer of claim 12, **characterized in that** said lateral extensions (523) have a general C-shape that embrace the outer leg of said ferrite core (4).
  15. The transformer of any of claims 12 to 14, **characterized in that** said lateral extensions (523) of said cover cap (52) extend longitudinally over the whole length of the portion of said core (4) associated with said secondary winding (32).
  16. The transformer of any of the previous claims, **characterized in that** said bobbin (2) includes a separating wall (320) between said primary (21) and secondary (22) winding chambers cooperating in a labyrinth-like arrangement with said cover cap (52), said labyrinth-like arrangement including:
    - a groove (321) in one (320) of said separating wall (320) and said cover cap (52), and
    - a wall formation (521) adapted to interpenetratingly extend into said groove (321), said wall formation protruding from the other (52) of said separating wall (320) and said cap (52).
  17. The transformer of any of the previous claims, **characterized in that** said bobbin (2) includes an end wall at the distal end of said secondary winding chamber (22) exposed to said core (4), said end wall of having associated a labyrinth-like arrangement including:
    - a groove (323) in one (322) of said end wall (322) and said cover cap (52), and
    - a wall formation (522) adapted to interpenetratingly extend into said groove (323), said wall formation protruding from the other (52) of said end (322) and said cap (52).
  18. The transformer of any of the previous claims, **characterized in that** said bobbin (2) includes "L" shaped notches (324) at the distal end of said secondary winding chamber (22) exposed to said core (4), said

notches having associated a labyrinth-like arrangement including:

- the notches themselves (324), and
- the "L" shaped wall formations (524) adapted to interpenetratingly extend into said notches (324), said wall formation protruding from said cover cup (52), and
- the inner vertical part of the lateral extension (523) exposed to said bobbin (2).

includes the step of causing the solder used for said soldering to fill the interstices between adjacent wires in said Litz wire or braid wires.

19. The transformer of any of the previous claims, **characterized in that** said bobbin (2) has a associated electrical connection pins (6) for the ends of said secondary winding (32) and wherein the creepage and clearance distance between said ferrite core (4) and said secondary pins (6) is at least 7.2 mm.

20. The transformer of any of the previous claims, **characterized in that** said cover cap (52) has a decreasing height starting from the area between said primary (21) and secondary (22) chamber outwardly of the transformer (1).

21. A method of assembling a transformer (1), the transformer including:

- a bobbin (2) defining primary (21) and secondary (22) winding chambers,
- a core (4) mounted on said bobbin (2),
- primary (31) and secondary (32) windings wound in said primary (21) and secondary (22) winding chambers, respectively, and
- at least one set of contact pins (7, 6) associated with the ends (W) of at least one of said primary (31) and secondary (32) windings, the method including the steps of:
  - providing said bobbin (2), in the proximity of said at least one set of pins (6), with a set of apertures (8) forming guide formations for the ends (W) of said at least one of said primary (31) and secondary (32) windings,
  - arranging said ends (W) of said at least one of said primary (31) and secondary (32) windings in the apertures of said set (8), whereby said ends (W) are located in the proximity of said at least one set of pins (6), and
  - soldering said ends (W) to the pins (6) of said at least one set, while said ends (W) are retained in by said apertures (8) in proximity of said at least one set of pins (6).

22. The method of claim 21, **characterized in that** it includes the step of selecting said at least one of said primary (31) and secondary (32) windings out of Litz wire and braid of wires.

23. The method of claim 22, **characterized in that** it

FIG. 1

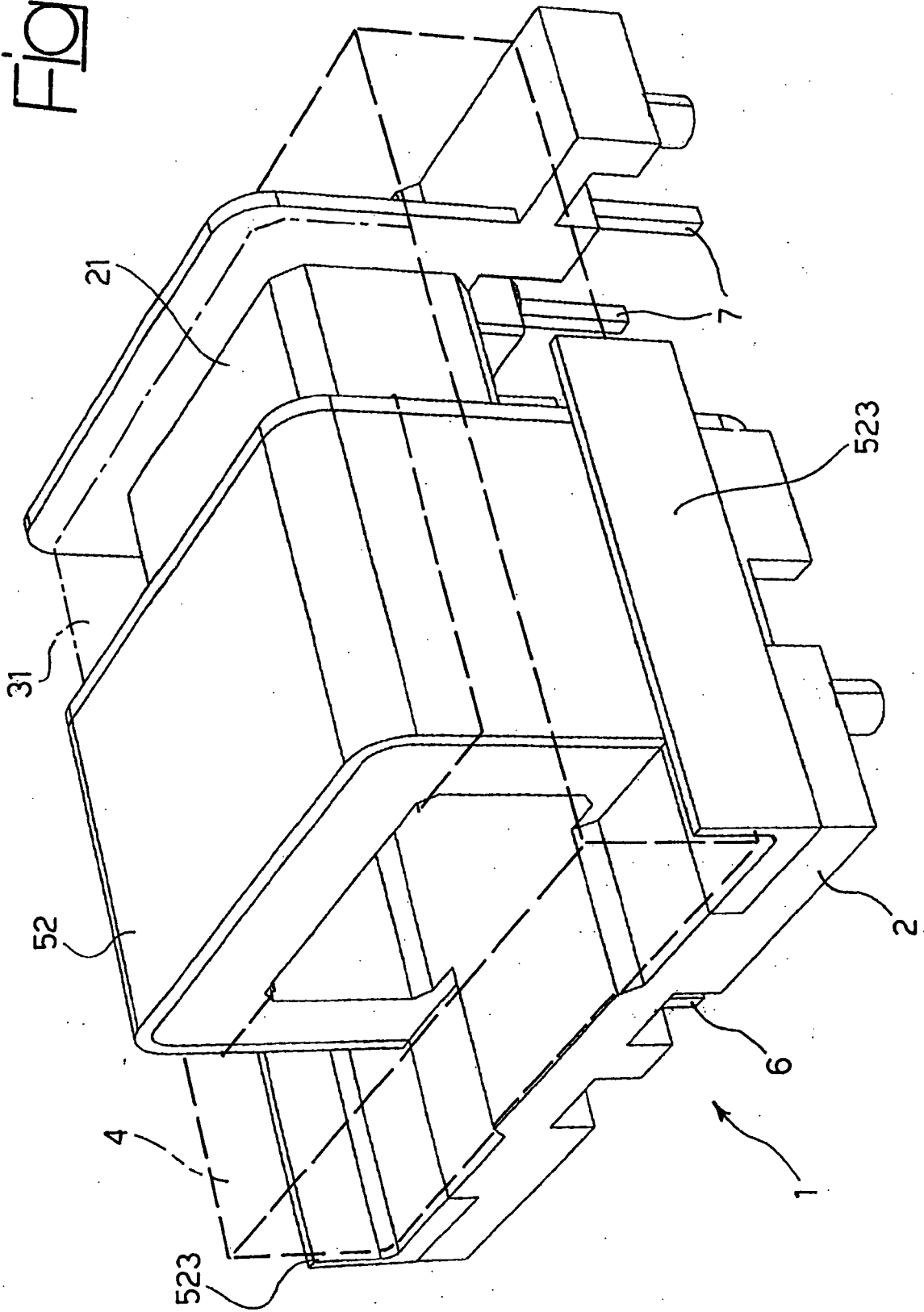

Fig. 2

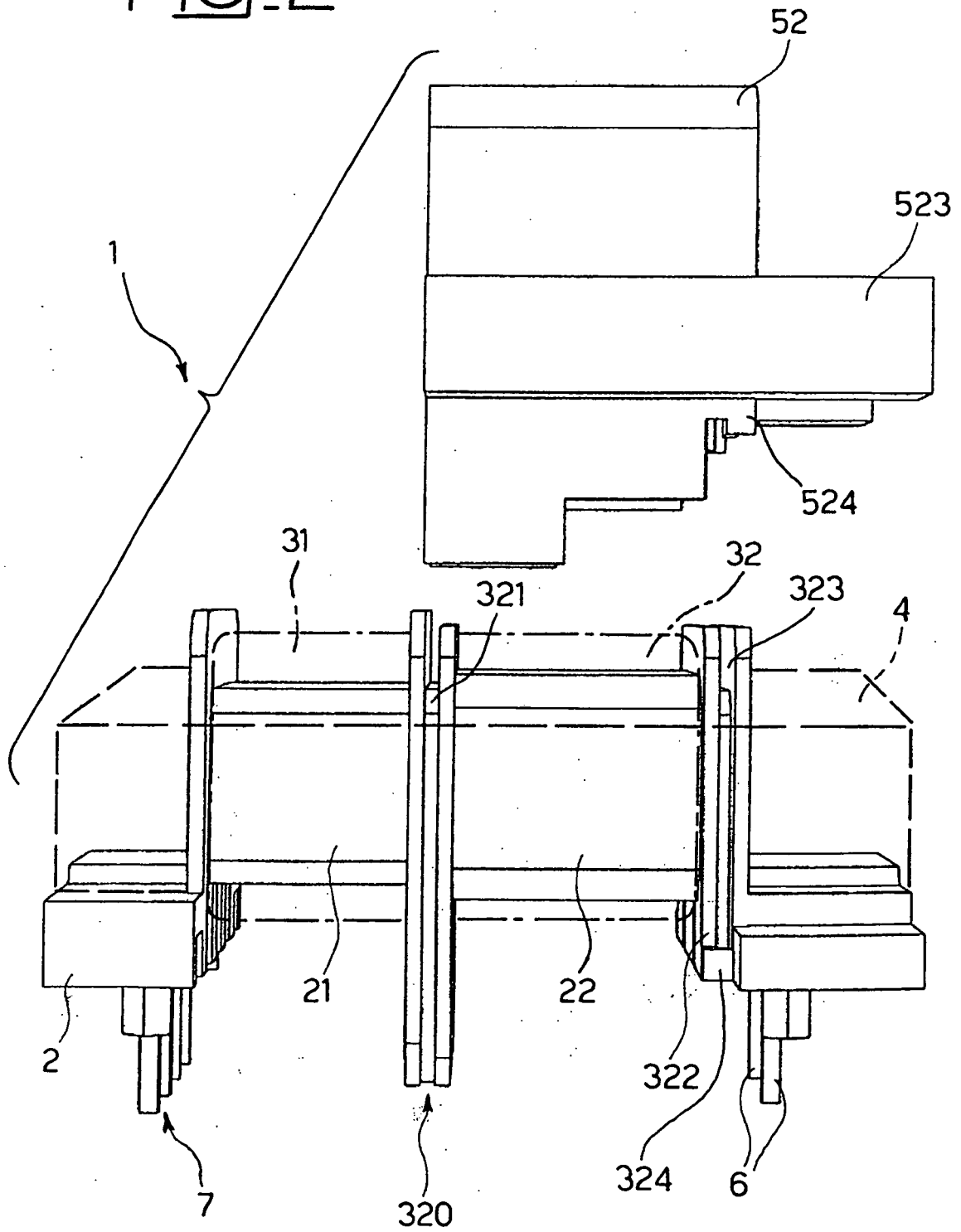

Fig. 3

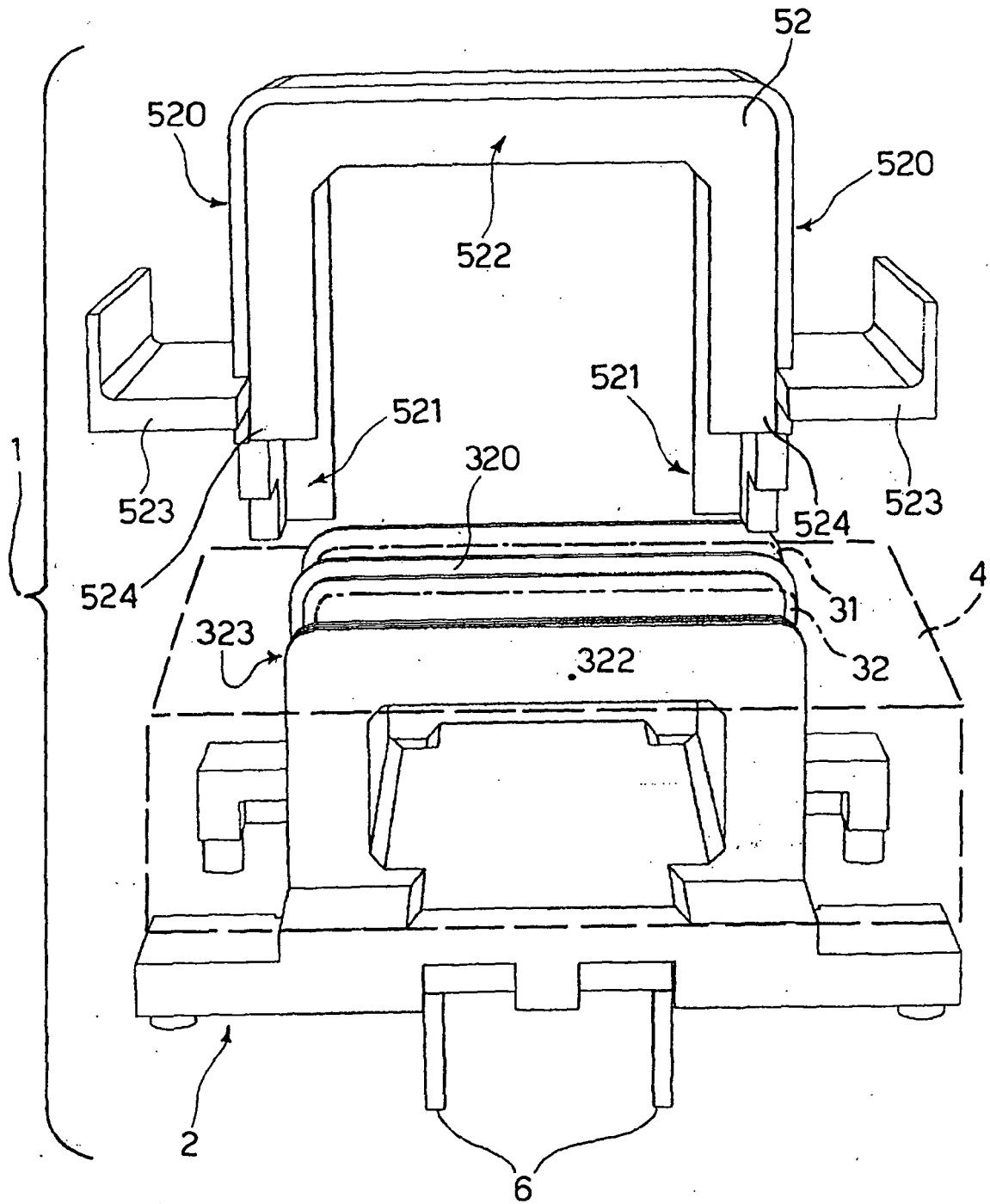
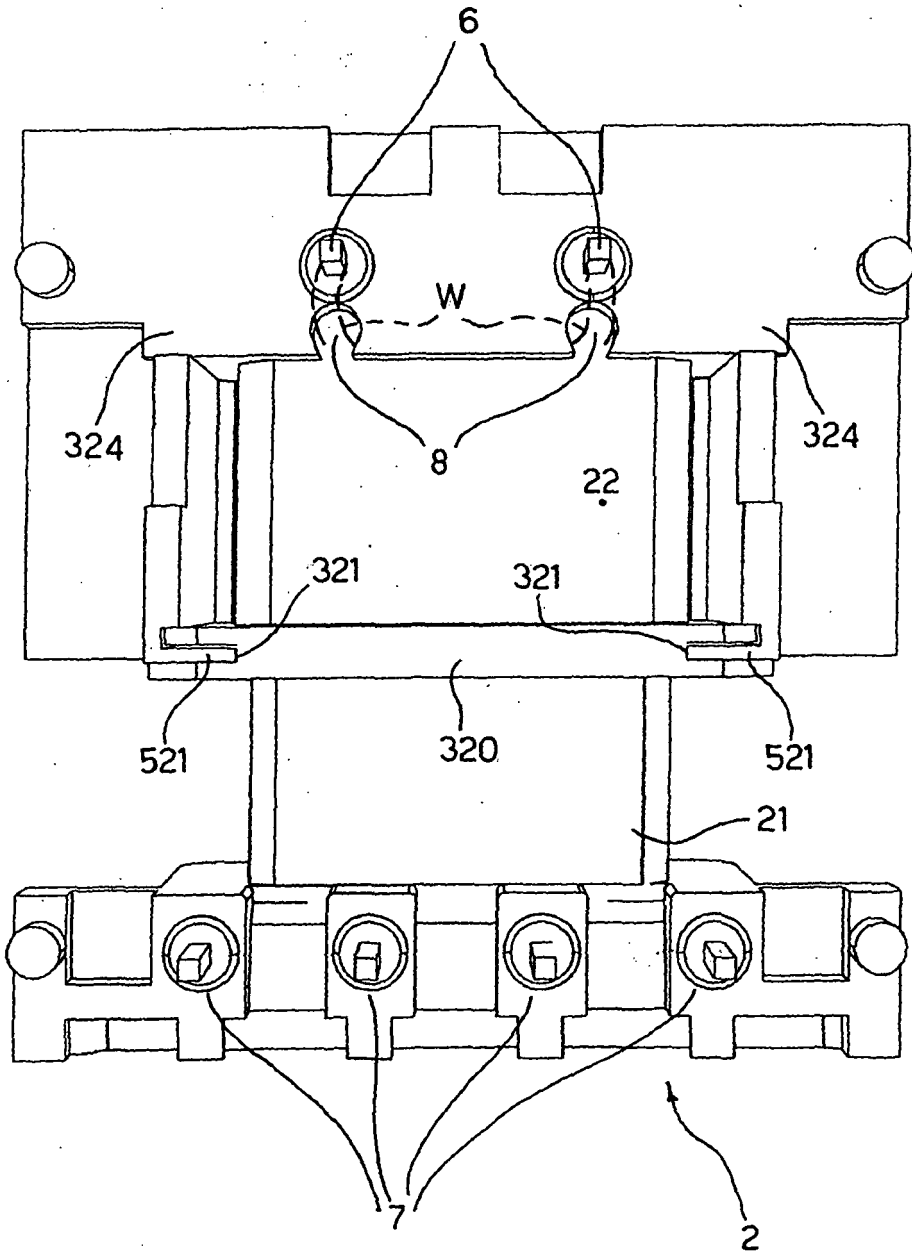

Fig. 4





European Patent Office

**PARTIAL EUROPEAN SEARCH REPORT**

Application Number: EP 04 42 5853

which under Rule 45 of the European Patent Convention shall be considered, for the purposes of subsequent proceedings, as the European search report

DOCUMENTS CONSIDERED TO BE RELEVANT			
Category	Citation of document with indication, where appropriate, of relevant passages	Relevant to claim	CLASSIFICATION OF THE APPLICATION (Int.Cl.7)
Y	DE 23 26 126 A1 (TABUCHI DENKI K.K., OSAKA ; TABUCHI DENKI K.K., OSAKA, JP) 10 January 1974 (1974-01-10) * page 3, line 7 - page 5, line 15; figures 1,2 *	1,3,4, 6-9,11, 12,15-17	H01F27/32 H01F41/10
Y	US 4 405 913 A (FINKBEINER ET AL) 20 September 1983 (1983-09-20)  * column 6, lines 14-29 * * column 8, lines 38-60; figures 10,11 *	1,3-5, 7-10,16, 17	
Y	"Bobbin set for a low profile, safety approved transformer" IBM TECHNICAL DISCLOSURE BULLETIN, vol. 30, no. 11, April 1988 (1988-04), pages 58-59, XP002324725 * the whole document *	1,3,6-9, 11,12, 15,16,19	
Y	US 4 980 664 A (HARWOOD ET AL) 25 December 1990 (1990-12-25) * abstract; figures 1-19 * * column 3, lines 28-68 *	1,3,19	
			TECHNICAL FIELDS SEARCHED (Int.Cl.7)
			H01F
-/--			
<b>INCOMPLETE SEARCH</b>			
The Search Division considers that the present application, or one or more of its claims, does/do not comply with the EPC to such an extent that a meaningful search into the state of the art cannot be carried out, or can only be carried out partially, for these claims.			
Claims searched completely :			
Claims searched incompletely :			
Claims not searched :			
Reason for the limitation of the search: see sheet C			
Place of search Munich		Date of completion of the search 15 April 2005	Examiner Reder, M
CATEGORY OF CITED DOCUMENTS X : particularly relevant if taken alone Y : particularly relevant if combined with another document of the same category A : technological background O : non-written disclosure P : intermediate document		T : theory or principle underlying the invention E : earlier patent document, but published on, or after the filing date D : document cited in the application L : document cited for other reasons & : member of the same patent family, corresponding document	

4  
EPO FORM 1503 03.02 (P04/C07)



DOCUMENTS CONSIDERED TO BE RELEVANT			CLASSIFICATION OF THE APPLICATION (Int.Cl.7)
Category	Citation of document with indication, where appropriate, of relevant passages	Relevant to claim	
Y	GB 1 240 795 A (STANLEY R. POOLE) 28 July 1971 (1971-07-28) * page 1, lines 11-25 *	1	
A	* page 1, line 81 - page 2, line 34; figures 1-5 *	19	
Y	----- HESS J: "WHAT'S NEW IN FERRITES" COMPONENTS, SIEMENS AKTIENGESELLSCHAFT. MUNCHEN, DE, vol. 26, no. 4 / 5, 1 October 1991 (1991-10-01), pages 142-146, XP000266912 ISSN: 0945-1137 * page 144, left-hand column, lines 12-27; figure 2; table 1 *	1,3-12, 15-17	
			TECHNICAL FIELDS SEARCHED (Int.Cl.7)
A	----- FERROXCUBE: "EFD 25/13/9: EFD cores and accessories, data sheet" 1 September 2004 (2004-09-01), , XP002324726 Retrieved from the Internet: URL:http://:www..ferrite.de/fxc2005/p.pdf> * the whole document *	1-20	
A,D	----- EP 0 793 243 A (PATENT-TREUHAND-GESELLSCHAFT FUER ELEKTRISCHE GLUEHLAMPEN MBH) 3 September 1997 (1997-09-03) * abstract *	1-20	



Claim(s) searched completely:  
1,3-20

Claim(s) not searched:  
2

Reason for the limitation of the search:

The compliance of the claimed transformer with the norms EN 61347 and UL 1310 is a result to be achieved. It is not specified by which technical features this result is thought to be achieved.

**CLAIMS INCURRING FEES**

The present European patent application comprised at the time of filing more than ten claims.

Only part of the claims have been paid within the prescribed time limit. The present European search report has been drawn up for the first ten claims and for those claims for which claims fees have been paid, namely claim(s):

No claims fees have been paid within the prescribed time limit. The present European search report has been drawn up for the first ten claims.

**LACK OF UNITY OF INVENTION**

The Search Division considers that the present European patent application does not comply with the requirements of unity of invention and relates to several inventions or groups of inventions, namely:

see sheet B

All further search fees have been paid within the fixed time limit. The present European search report has been drawn up for all claims.

As all searchable claims could be searched without effort justifying an additional fee, the Search Division did not invite payment of any additional fee.

Only part of the further search fees have been paid within the fixed time limit. The present European search report has been drawn up for those parts of the European patent application which relate to the inventions in respect of which search fees have been paid, namely claims:

None of the further search fees have been paid within the fixed time limit. The present European search report has been drawn up for those parts of the European patent application which relate to the invention first mentioned in the claims, namely claims:

1-20



The Search Division considers that the present European patent application does not comply with the requirements of unity of invention and relates to several inventions or groups of inventions, namely:

1. claims: 1-20

A transformer with primary and secondary windings arranged in isolated winding chambers of a bobbin and a core mounted on the bobbin with the core being an EFD core and a cover cap over the secondary winding in combination with the bobbin providing reinforced insulation of the secondary winding.

---

2. claims: 21-23

A transformer with primary and secondary windings arranged in isolated winding chambers of a bobbin and a core mounted on the bobbin with at least one set of contact pins connected with the winding ends and apertures in the bobbin near the contact pins for guiding and holding the winding ends during soldering the winding ends to the pins.

---

**ANNEX TO THE EUROPEAN SEARCH REPORT  
ON EUROPEAN PATENT APPLICATION NO.**
EP 04 42 5853<sup>18</sup>

This annex lists the patent family members relating to the patent documents cited in the above-mentioned European search report. The members are as contained in the European Patent Office EDP file on  
The European Patent Office is in no way liable for these particulars which are merely given for the purpose of information.

15-04-2005

Patent document cited in search report		Publication date	Patent family member(s)	Publication date
DE 2326126	A1	10-01-1974	JP 895366 C	30-01-1978
			JP 49014926 A	08-02-1974
			JP 52024970 B	05-07-1977
			JP 900096 C	15-03-1978
			JP 49043122 A	23-04-1974
			JP 52028210 B	25-07-1977
US 4405913	A	20-09-1983	US 4510478 A	09-04-1985
US 4980664	A	25-12-1990	NONE	
GB 1240795	A	28-07-1971	DE 2005939 A1	03-09-1970
			FR 2030435 A7	13-11-1970
EP 0793243	A	03-09-1997	DE 19607714 A1	04-09-1997
			CA 2198656 A1	29-08-1997
			DE 59703458 D1	07-06-2001
			EP 0793243 A1	03-09-1997
			US 5783982 A	21-07-1998
JP 08306555	A	22-11-1996	NONE	
JP 09312221	A	02-12-1997	NONE	