



(12) **EUROPEAN PATENT APPLICATION**

(43) Date of publication: **02.08.2006 Bulletin 2006/31** (51) Int Cl.: **F24F 13/12^(2006.01)**

(21) Application number: **05258105.5**

(22) Date of filing: **29.12.2005**

(84) Designated Contracting States:
**AT BE BG CH CY CZ DE DK EE ES FI FR GB GR
HU IE IS IT LI LT LU LV MC NL PL PT RO SE SI
SK TR**
Designated Extension States:
AL BA HR MK YU

(72) Inventors:
• **Kim, Kang Young**
Masan-si, Gyeongsangnam-do (KR)
• **Ahn, Min**
Changwon-si, Gyeongsangnam-do (KR)

(30) Priority: **30.12.2004 KR 2004116241**
30.12.2004 KR 2004116242
15.04.2005 KR 2005031473

(74) Representative: **Palmer, Jonathan R.**
Boulton Wade Tennant,
Verulam Gardens,
70 Gray's Inn Road
London WC1X 8BT (GB)

(71) Applicant: **LG ELECTRONICS INC.**
Seoul (KR)

(54) **Indoor unit of air-conditioning system**

(57) An indoor unit of an air-conditioning system is disclosed, in which air outlets (101,102,103) are desirably opened and closed. The indoor unit of the air-conditioning system includes a cabinet (100) having at least one or more air inlets (104,105,106) and air outlets

(101,102,103) and receiving a blower (400) and a heat exchanger (300) therein, the blower (400) forcibly urging air flow and the air outlets (101,102) being respectively formed at one side and the other side, and outlet doors (210,220) movably provided in the cabinet (100) to open and close the air outlets (101,102).

FIG. 7

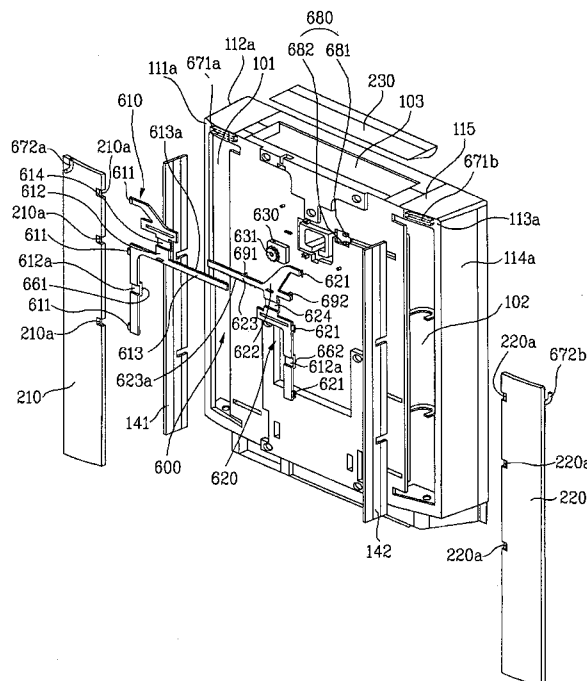

Description**BACKGROUND OF THE INVENTION****Field of the Invention**

[0001] The present invention relates to a separate air-conditioning system, and more particularly, to an indoor unit of an air-conditioning system that is provided in a room to cool and heat the indoor air.

Discussion of the Related Art

[0002] Generally, an air-conditioning system is equipped with a compressor and a heat exchanger to cool or heat indoor places such as living places, restaurants, libraries, or offices by flowing a refrigerant therein. The air-conditioning system is generally divided into a separate air-conditioning system and an integral air-conditioning system.

[0003] The integral air-conditioning system includes an outdoor unit and an indoor unit formed in a single body without being separated from each other. The outdoor unit and the indoor unit are directly provided in a house in a state that they are built in a wall or hung on a window.

[0004] The separate air-conditioning system includes an indoor unit provided with a heat exchanger that carries out room cooling or room heating, an outdoor unit provided with a heat exchanger that performs heat exchange with the outdoor air, and a refrigerant pipe that connects the indoor unit with the outdoor unit.

[0005] In the separate air-conditioning system, the indoor unit and the outdoor unit are separately provided so that the indoor unit is provided at the indoor and the outdoor unit is provided at the outdoor.

[0006] Hereinafter, a related art indoor unit of a separate air-conditioning system will be described with reference to FIG. 1.

[0007] Referring to FIG. 1, the door unit of the separate air-conditioning system includes a heat exchanger (not shown), a blower (not shown), and a cabinet 10 that receives the heat exchanger and the blower therein.

[0008] Air outlets 11a, 11b and 11c are provided at an upper portion of the cabinet 10 to discharge the conditioned air while air inlets 12a, 12b and 12c are provided at a lower portion of the cabinet to suck the air.

[0009] The air outlets 11a, 11b and 11c are respectively formed at both the upper portion of the front surface of the cabinet and left and right side portions of the cabinet. The left and right side portions are formed at a predetermined angle from the front surface of the cabinet.

[0010] Of the air outlets 11a, 11b, and 11c, the air outlet formed at the upper portion of the front surface of the cabinet is referred to as the front air outlet 11a, and the air outlets respectively formed at the left and right sides of the cabinet are referred to as the left air outlet 11b and the right air outlet 11c.

[0011] Meanwhile, the air outlets 11a, 11b and 11c are

respectively provided with vanes 13a, 13b and 13c. The vanes 13a, 13b and 13c are rotatably formed to control the wind of the air discharged from the air outlets 11a, 11b and 11c. Also, the vanes 13a, 13b and 13c serve to open and close the air outlets 11a, 11b and 11c.

[0012] However, the indoor unit of the air-conditioning system constructed as above has a problem. Since the vanes directly open and close the left and right air outlets, they may not be operated if foreign matters are adhered to their edges or the edges of the air outlets, thereby causing some error in opening and closing the air outlets.

SUMMARY OF THE INVENTION

[0013] Accordingly, the present invention is directed to an indoor unit of an air-conditioning system that substantially obviates one or more problems due to limitations and disadvantages of the related art.

[0014] An object of the present invention is to provide an indoor unit of an air-conditioning system in which air outlets are desirably opened and closed.

[0015] Additional advantages, objects, and features of the invention will be set forth in part in the description which follows and in part will become apparent to those having ordinary skill in the art upon examination of the following or may be learned from practice of the invention. The objectives and other advantages of the invention may be realized and attained by the structure particularly pointed out in the written description and claims hereof as well as the appended drawings.

[0016] To achieve these objects and other advantages and in accordance with the purpose of the invention, as embodied and broadly described herein, an indoor unit of an air-conditioning system according to the present invention includes a cabinet having at least one or more air inlets and air outlets and receiving a blower and a heat exchanger therein, the blower forcibly urging air flow and the air outlets being respectively formed at one side and the other side, and outlet doors movably provided in the cabinet to open and close the air outlets.

[0017] The cabinet is provided with a door driving gear that drives the outlet doors.

[0018] The door driving gear includes a door transfer unit that transfers the outlet doors, and a driving portion that drives the door transfer unit.

[0019] The door transfer unit is driven by a single motor provided in the driving portion to simultaneously open and close the outlet doors.

[0020] The door transfer unit switches a rotational motion generated by the driving portion to a rectilinear motion to reciprocate the outlet doors.

[0021] The transfer unit includes a first transfer body provided in the outlet door that opens and closes the air outlet formed at one side of the cabinet, and a second transfer body provided in the outlet door that opens and closes the air outlet formed at the other side of the cabinet.

[0022] The first transfer body includes a first rack, and

the second transfer body includes a second rack.

[0023] Preferably, the first and second racks are engaged with a pinion gear that is rotated by the single motor provided in the driving portion.

[0024] Preferably, the outlet doors are rotatably connected to the door transfer unit.

[0025] The outlet doors are rotatably connected to the door transfer unit by hooks.

[0026] Preferably, the door driving gear further includes a guide that guides the door transfer unit.

[0027] The guide includes guide bosses formed at any one of the cabinet and the door transfer unit and guide slots formed at the other of the cabinet and the door transfer unit, the guide slots being longitudinally formed in a transfer direction of the door transfer unit to insert the guide bosses therein.

[0028] Preferably, the guide includes a support that guides the door transfer unit and at the same time prevents the door transfer unit from being detached.

[0029] The indoor unit of the air-conditioning system further includes a friction damper that minimizes friction between the door transfer unit and the cabinet.

[0030] The friction damper includes slip ribs projected at any one of the door transfer unit and the cabinet and linearly in contact with the other of the door transfer unit and the cabinet.

[0031] The friction damper includes a roller that is provided at any one of the door transfer unit and the cabinet.

[0032] The door transfer unit transfers the outlet doors to open any one of the air outlets and close the other of the air outlets.

[0033] The door transfer unit includes a transfer body of which one side is connected to any one of the outlet doors and the other side is connected to the other of the outlet doors.

[0034] The outlet doors are rotatably connected to the transfer body.

[0035] The indoor unit of the air-conditioning system further includes a position sensor that senses opening and closing of the outlet doors.

[0036] The position sensor includes a photo sensor that senses at least one sensed portion provided at a predetermined portion of any one of the door transfer unit and the outlet doors.

[0037] The cabinet further includes a front cover that covers the door driving gear and at least one outlet door fully opened.

[0038] The indoor unit of an air-conditioning system further includes a door guide that guides each outlet door.

[0039] The door guide includes door guide grooves formed at any one of each outlet door and the cabinet, and door guide bosses at formed at the other of each outlet door and the cabinet and inserted into the door guide grooves, the door guide bosses being transferred relatively with respect to the door guide grooves when the outlet door is transferred.

[0040] Preferably, the air outlets are formed at left and right side portions of the cabinet.

[0041] The cabinet further includes an upper air outlet formed at an upper side thereof.

[0042] Preferably, the air outlets are spaced apart from each other toward the rear to form a predetermined angle from a front surface of the cabinet.

[0043] The indoor unit of the air-conditioning system further includes a wind controller provided at the air outlets to control the wind of the air discharged through the air outlets.

[0044] The wind controller changes the wind of the air discharged through the air outlets in left and right directions or up and down directions.

[0045] It is to be understood that both the foregoing general description and the following detailed description of the present invention are exemplary and explanatory and are intended to provide further explanation of the invention as claimed.

BRIEF DESCRIPTION OF THE DRAWINGS

[0046] The accompanying drawings, which are included to provide a further understanding of the invention and are incorporated in and constitute a part of this application, illustrate embodiment(s) of the invention and together with the description serve to explain the principle of the invention. In the drawings:

FIG. 1 is a front view illustrating a related art indoor unit of an air-conditioning system;

FIG. 2 is a perspective view illustrating an indoor unit of an air-conditioning system according to the first embodiment of the present invention;

FIG. 3 is a perspective view illustrating the state that the indoor unit of FIG. 2 is operating;

FIG. 4 is a front view illustrating the state that indoor unit of FIG. 2 is operating;

FIG. 5 is an exploded perspective view illustrating the indoor unit of the air-conditioning system according to the first embodiment of the present invention;

FIG. 6 is a sectional view illustrating the indoor unit of the air-conditioning system according to the first embodiment of the present invention;

FIG. 7 is an exploded perspective view illustrating a door driving gear of the indoor unit of the air-conditioning system according to the first embodiment of the present invention;

FIG. 8 is a perspective view illustrating the state that left and right outlet doors are opened by the door driving gear of FIG. 7;

FIG. 9 is a perspective view illustrating the state that the left and right outlet doors are closed by the door driving gear of FIG. 7;

FIG. 10 is an exploded perspective view illustrating a door driving gear of an indoor unit of the air-conditioning system according to the second embodiment of the present invention;

FIG. 11 is a perspective view illustrating the door driving gear of FIG. 10;

FIG. 12 is a perspective view illustrating the state that the left outlet door is opened by the door driving gear of FIG. 11;

FIG. 13 is a perspective view illustrating the state that the right outlet door is opened by the door driving gear of FIG. 11;

FIG. 14 is a front view illustrating the state that the indoor unit of the air-conditioning system according to the second embodiment of the present invention is operated in an opening mode of a left air outlet; FIG. 15 is a perspective view illustrating the state that the indoor unit of the air-conditioning system according to the second embodiment of the present invention is operated in an opening mode of a right air outlet;

FIG. 16 is a perspective view illustrating an indoor unit of an air-conditioning system according to the third embodiment of the present invention;

FIG. 17 is a front view illustrating the indoor unit of FIG. 16;

FIG. 18 is a perspective view illustrating an indoor unit of an air-conditioning system according to the fourth embodiment of the present invention; and

FIG. 19 is a perspective view illustrating an indoor unit of an air-conditioning system according to the fifth embodiment of the present invention.

DETAILED DESCRIPTION OF THE INVENTION

[0047] Reference will now be made in detail to the preferred embodiments of the present invention, examples of which are illustrated in the accompanying drawings. Wherever possible, the same reference numbers will be used throughout the drawings to refer to the same or like parts.

[0048] Referring to FIG. 2 to FIG. 4, an indoor unit of an air-conditioning system according to the first embodiment of the present invention includes a cabinet 100 provided with various elements of the indoor unit.

[0049] Air outlets 101 and 102 are formed at one side and the other side of the cabinet 100 to discharge the air. The air outlets 101 and 102 are opened and closed by outlet doors 210 and 220 that are movably provided in the cabinet 100.

[0050] In more detail, the outlet doors 210 and 220 are preferably formed at left and right side portions of the cabinet 100.

[0051] Hereinafter, for convenience of description, the air outlet formed at the left side portion of the cabinet 100 is referred to as the left air outlet 101, and the air outlet formed at the right side portion of the cabinet 100 is referred to as the right air outlet 102.

[0052] The outlet door that opens and closes the left air outlet 101 is referred to as the left outlet door 210, and the outlet door that opens and closes the right air outlet 102 is referred to as the right outlet door 220.

[0053] The left and right air outlets 101 and 102 are formed at both edge portions of the front surface of the

cabinet 100 so that they are to be flush with the front surface of the cabinet 100. Alternatively, the left and right air outlets 101 and 102 may be formed at both side portions of the front surface of the cabinet 100.

5 [0054] Further, the left and right air outlets 101 and 102 are preferably formed above the left and right side portions of the cabinet 100. More specifically, the left and right air outlets 101 and 102 are longitudinally formed above the left and right side portions of the cabinet 100 in up and down directions.

10 [0055] In addition, an upper air outlet 103 is preferably formed at an upper side of the cabinet 100.

[0056] Meanwhile, at least one air inlet is preferably formed at a lower portion of the cabinet 100, so that the indoor air is sucked to the air inlet.

15 [0057] In the first embodiment of the present invention, a left air inlet 105 and a right air inlet 106 are longitudinally formed below the left and right side portions of the cabinet 100 in a vertical direction.

20 [0058] A front air inlet 104 is formed at a lower end of the front surface of the cabinet 100.

[0059] However, it is noted that the number of the air inlets and their positions are not limited to above cases.

25 [0060] The front air inlet 104, the left air inlet 105, and the right air inlet 106 are formed at the lower portion of the cabinet 100.

[0061] Next, the indoor unit of the air-conditioning system will be described in more detail with reference to FIG. 5 and FIG. 6.

30 [0062] Referring to FIG. 5 and FIG. 6, a heat exchanger 300 and a blower 400 are received in the cabinet 100. The heat exchanger 300 serves to cool and heat the air while the blower 400 serves to forcibly flow the air.

35 [0063] The blower 400 is provided at a lower portion inside the cabinet 100 and the heat exchanger 300 is slantingly provided above the blower 400 to perform heat exchange with the air discharged from the blower 400.

[0064] The cabinet 100 includes a front cabinet 110, a rear cabinet 120, and a base 130. The base 130 supports lower portions of the front and rear cabinets 110 and 120.

40 [0065] The front cabinet 110 is fixed to the front end of the rear cabinet 120 to form a space that receives the blower 400 and the heat exchanger 300.

45 [0066] The front cabinet 110 has a rear side and a bottom that are opened. The front cabinet 110 includes a front surface, left side portions 111 and 112, and right side portions 113 and 114. The left and right side portions are provided at both sides of the front surface.

50 [0067] Thus, the cabinet 100 provided with the left and right air outlets 101 and 102 include the left and right side portions 111 to 114.

55 [0068] The left and right side portions of the front cabinet 110 may be extended toward the rear in a vertical direction from the front surface of the front cabinet 110. However, it is preferable that the left and right side portions of the front cabinet 110 include a left slant surface 111a and a right slant surface 113a that are spaced apart from each other toward the rear at a predetermined angle

from the front surface of the front cabinet 110.

[0069] A slant angle between the front surface of the front cabinet 110 and the left slant surface 111a and a slant angle between the front surface of the front cabinet 110 and the right slant surface 113a are preferably within the range of 15° to 25°, more specifically, 20°. However, the slant angles are not limited to the above range.

[0070] The left slant surface 111a and the right slant surface 113a may be replaced with a left plane portion (not shown) and a right plane portion (not shown) that are substantially flush with the front surface of the front cabinet. The left air outlet 101 and the right air outlet 102 may respectively be formed at the left plane portion and the right plane portion.

[0071] In addition, the front cabinet further include left and right side portions 112 and 114 extended from the rear ends of the left and right slant surfaces 111a and 113a to their rear directions at a predetermined angle from the left and right slant surfaces 111a and 113a.

[0072] The left and right side portions 112 and 114 may be substantially vertical to the front surface of the front cabinet 110.

[0073] The upper half of the front cabinet 110 provided with the air outlets 101, 102 and 103 and the lower half of the front cabinet 110 provided with the left and right air inlets 105 and 106 may separately provided to be detached from each other.

[0074] Preferably, the lower front surface of the front cabinet 110 may be opened to easily repair or clean various elements received in the cabinet 100.

[0075] In this embodiment, the left lower half provided with the left air inlet 105 is made of a left lower panel separately provided. The right lower half provided with the right air inlet 106 is also made of a right lower panel separately provided.

[0076] Therefore, if the left lower panel and the right lower panel are fixed to the upper half of the front cabinet, an opening is formed between the left lower panel and the right lower panel.

[0077] Meanwhile, the left air outlet 101 and the right air outlet 102 are respectively formed at the left side portions 111 and 112 and the right side portions 113 and 114 corresponding to the upper half of the front cabinet.

[0078] More specifically, the left and right air outlets 101 and 102 are respectively formed at the left slant surface 111a and the right slant surface 113a of the upper half of the front cabinet 110.

[0079] The left air inlet 105 and the right air inlet 106 are respectively formed at both sides 112b and 114b of the lower half of the front cabinet 110, i.e., at the left and right sides of the lower half.

[0080] However, the left air outlet 101 and the right air outlet 102 may respectively be formed at both sides 112a and 114a of the upper half of the front cabinet 110. Alternatively, the left air outlet 101 and the right air outlet 102 may respectively be formed at a left slant surface 111b and a right slant surface 113b of the lower half of the front cabinet.

[0081] In addition, it is preferable that a wind controller that controls the wind of the discharged air is respectively provided at the left air outlet 101 and the right air outlet 102.

5 **[0082]** In this embodiment, a plate shaped left wind vane 141 is provided at the left air outlet 101 and a plate shaped right wind vane 142 is provided at the right air outlet 102.

10 **[0083]** Upper and lower ends of the left and right wind vanes 141 and 142 are rotatably connected with upper and lower ends of the left and right air outlets 101 and 102, and driving motors 141a and 142a are connected to any one of the upper and lower ends of the left and right wind vanes 141 and 142 to change the wind of the discharged air to left and right directions.

15 **[0084]** A door driving gear 600 is provided at the upper portion of the front surface of the front cabinet 110 to drive the left and right outlet doors 210 and 220.

20 **[0085]** The door driving gear is covered with a front cover 150 constituting the front surface of the upper half of the front cabinet 110, and a fitting plate 160 is provided at the rear of the front cover 150 to fit the door driving gear. The door driving gear will be described later in detail with reference to FIG. 7 to FIG. 9.

25 **[0086]** The upper air outlet 103 is formed at an upper side 115 substantially vertical to the front surface of the front cabinet 110.

30 **[0087]** The upper air outlet 103 is provided with an upper door 230 rotated by a separate driving motor 231. The upper door 230 opens and closes the upper air outlet 103 and at the same time controls the wind of the discharged air.

35 **[0088]** Next, left and right inlet vanes 143 and 144 are rotatably provided at the left and right air inlets 105 and 106, respectively. The left and right inlet vanes 143 and 144 open and close the left and right air inlets 105 and 106 and at the same time guide the sucked air.

40 **[0089]** Upper and lower ends of the left and right inlet vanes 143 and 144 are rotatably connected with upper and lower ends of the left and right air inlets 105 and 106, and separate driving motors 143a and 144a are connected to any one of the upper and lower ends of the left and right inlet vanes 143 and 144.

45 **[0090]** Further, filter setting portions 161 and 162 are provided inside the left and right air inlets 105 and 106 so that left and right air filters 161a and 162a are set therein. The air filters 161a and 162a are drawn out through the opened front surface of the lower half of the front cabinet 110.

50 **[0091]** The front cabinet 110 constructed as above is fixed to the upper portion of the base 130, and the front air inlet 104 is formed at the base 130.

55 **[0092]** A filter assembly 163 is preferably provided at the upper surface of the base 130, particularly, the upper side of the front air inlet 104. The filter assembly 163 purges the air sucked through the front air inlet 104.

[0093] The filter assembly 163 includes a plurality of filters 163a, 163b and 163c arranged up and down. Pref-

erably, the filters are comprised of hepa-filters and high performance filters such as nano-filters that remove odor particles or bacilli.

[0094] Meanwhile, the rear cabinet 120 has an opened front surface and an opened bottom, and its horizontal section has a trapezoidal shape enlarged toward the front to improve space utility if the indoor unit is provided at a corner of a room.

[0095] An upper panel 121 downwardly slanted toward the rear to form a ceiling of the rear cabinet 120 is fixed to the upper portion of the rear cabinet 120.

[0096] A front door 170 is provided at the front of the aforementioned cabinet 100 to cover the front surface of the front cabinet 110.

[0097] One side at the lower end of the front door 170 is rotatably connected with the base 130 and one side at the upper end of the front door 170 is rotatably connected with the upper end of the front cabinet 110.

[0098] The front door 170 includes a glass 171, a door plate 172 provided at the rear of the glass 171, and a door frame 173. The door frame 173 is rotatably connected with the base 130 and the front cabinet 110 to support the glass 171 and the door plate 172.

[0099] The door plate 172 is provided with an opening hole 172a, and a display 174 is provided at the rear side of the door plate 172 to display various information such as driving information through the opening hole 172a and the glass 171.

[0100] Meanwhile, the blower 400 sucks the indoor air through the air inlets 104, 105 and 106 and forcibly urges air flow to allow the sucked air to be discharged out through the heat exchanger 300 and the air outlets 101, 102 and 103.

[0101] The blower 400 includes a blower housing 410 provided at the lower portion inside the cabinet 100 and a blower fan 420 provided inside the blower housing 410.

[0102] The blower housing 410 has an opened front surface to communicate with an orifice 430 that guides the air sucked through the air inlets. An air outlet hole 411 is formed at the upper surface of the blower housing 410 to discharge the air toward an upward direction where the heat exchanger 300 is positioned.

[0103] As an example of the blower fan 420, there is provided a turbo fan that axially sucks the air by means of driving of a blower motor 421 and radially discharges the air.

[0104] In addition, an electric dust collector 500 is preferably provided at the front of the orifice 430.

[0105] The electric dust collector 500 includes a high voltage generator 510, an ionizing portion 520, and a collecting portion 530.

[0106] The high voltage generator 510 applies a high voltage to the ionizing portion 520 to induce discharge. The ionizing portion 520 ionizes dust in the air using energy generated during discharge and irradiates light energy. The collecting portion 530 collects the ionized dust.

[0107] The heat exchanger 300 is provided at the upper side of the blower fan 420 slantingly from the front to

the rear, and is comprised of a refrigerant pipe that passes through refrigerant and a plurality of fins provided in the refrigerant pipe. The heat exchanger 300 is connected with a refrigerant pipe (not shown) that guides to the outdoor unit the refrigerant evaporated or condensed by heat exchange with the air.

[0108] A fan 310 is arranged below the heat exchanger 300 to store condensed water therein. The condensed water is generated on the surface of the heat exchanger 300 and dropped. A drain hose (not shown) is connected to one side of the fan 310 to drain the condensed water outside the indoor unit.

[0109] Hereinafter, the left and right outlet doors 210 and 220 and the door driving gear 600 will be described with reference to FIG. 7 to FIG. 9.

[0110] Referring to FIG. 7 to FIG. 9, the door driving gear 600 includes a door transfer unit transferring the left and right outlet doors 210 and 220, and a driving portion driving the door transfer unit.

[0111] The door transfer unit transfers the left and right outlet doors 210 and 220 in a horizontal direction so that the left and right air outlets 101 and 102 are opened and closed.

[0112] To reciprocate the left and right outlet doors 210 and 220 in a horizontal direction, the door transfer unit in this embodiment is constructed in such a manner that it switches a rotational motion generated by the driving portion to a rectilinear motion and transfers the rectilinear motion to the air outlet doors 210 and 220. However, the door transfer unit is not limited to such construction.

[0113] In detail, the door transfer unit includes a first transfer body 610 provided at the left outlet door 210 and a second transfer body 620 provided at the right outlet door 220.

[0114] Preferably, the first transfer body 610 and the second transfer body 620 are rotatably connected to the left outlet door 210 and the right outlet door 220, respectively. However, the first and second transfer bodies are not limited to such case.

[0115] The first and second transfer bodies may be formed in a single body in the same manner as those of the second embodiment that will be described later. In this embodiment, the first transfer body 610 and the second transfer body 620 are separately provided to respectively transfer the left outlet door 210 and the right outlet door 220.

[0116] To this end, at least one or more hooks 611 and 621 are provided at any one of the left outlet door 210 and the first transfer body 610. At least one or more shafts 210a and 220a are provided at the other of the left outlet door 210 and the first transfer body 610 and caught in the hooks 611 and 621 to form rotational shafts, so that the left outlet door 210 is rotatably connected with the first transfer body 610 and at the same time the left outlet door 210 is detachably connected with the first transfer body 610.

[0117] In this embodiment, a plurality of the shafts 210a are provided at the right side end of the left outlet

door 210, and a plurality of the hooks 611 respectively connected to the shafts 210a are provided at the left end of the first transfer body 610.

[0118] Preferably, the right outlet door 220 and the second transfer body 620 are connected with each other in the same manner as the left outlet door 210 and the first transfer body 610.

[0119] In other words, the plurality of shafts 220a are provided at the left end of the right outlet door 220, and the plurality of hooks 621 respectively connected to the shafts 220a are provided at the right end of the second transfer body 220.

[0120] In this way, the first transfer body 610 and the second transfer body 620 respectively connected to the left and right outlet doors 210 and 220 are preferably driven by a single motor 183.

[0121] To this end, the first transfer body 610 includes a first door link portion 612 and a first rack bar 613. The first door link portion 612 is provided with the hooks 611 connected to the shafts 210a of the left outlet door. The first rack bar 613 is extended from the right side of the first door link portion 612 to the second transfer body 620 at a predetermined length.

[0122] The second transfer body 620 includes a second door link portion 622 and a second rack bar 623. The second door link portion 622 is provided with the hooks 621 connected to the shafts 220a of the right outlet door. The second rack bar 623 is extended from the left side of the second door link portion 622 to the first transfer body 610 at a predetermined length.

[0123] The first rack bar 613 and the second rack bar 623 are respectively provided with a first rack 613a and a second rack 623a. The first rack 613a and the second rack 623a are preferably engaged with a pinion gear 631 rotated by a motor 630. The motor 630 is provided in the driving portion. The pinion gear 631 may directly be fixed to a shaft of the motor 630 to simplify its structure. Therefore, the door transfer unit can be driven by the single motor 630.

[0124] In this embodiment, the driving portion including the motor 630 is provided at a middle portion of the fitting plate 160 provided with the door driving gear. The first rack bar 613 is provided below the pinion gear 631, and the second rack bar 623 is provided above the pinion gear 631 in parallel with the first rack bar 613.

[0125] In such case, the first rack 613a is formed along the upper side of the first rack bar 613 to be engaged with the lower end of the pinion gear 631, and the second rack 632a is formed along the lower side of the second rack bar 623 to be engaged with the upper end of the pinion gear 631.

[0126] Meanwhile, the door driving gear is provided with a guide that guides the door transfer unit.

[0127] An example of the guide includes guide bosses 641 and 642 and guide slots 651 and 652. The guide bosses 641 and 642 are formed at any one of the cabinet 100 and the door transfer unit. The guide slots 651 and 652 are longitudinally formed at the other of the cabinet

100 and the door transfer unit in a transfer direction of the door transfer unit.

[0128] Referring to FIG. 7 to FIG. 9, the guide slots 651 and 652 are formed at a part of the first transfer body 610 and the second transfer body 620, particularly, the door link portions 612 and 622.

[0129] The guide bosses 641 and 642 corresponding to the guide slots 651 and 652 are projected from the fitting plate 160 of the cabinet to the front and respectively inserted into the guide slots 651 and 652.

[0130] Therefore, the guide bosses 641 and 642 and the guide slots 651 and 652 guide the first transfer body 610 and the second transfer body 620 when the first transfer body 610 and the second transfer body 620 are transferred in a horizontal direction by rotation of the pinion gear 631.

[0131] In addition, it is preferable that the guide further includes a support that guides the door transfer unit, i.e., the first transfer body 610 and the second transfer body 620 and at the same time prevents the first and second transfer bodies 610 and 620 from being detached from the door transfer unit.

[0132] As an example of the support, a first support rib 653a and a second support rib 653b are provided in the indoor unit of the air-conditioning system according to the present invention. The first support rib 653a supports one side of the first transfer body 610 while the second support rib 653b supports the second transfer body 620.

[0133] In more detail, the first support rib 653a is projected from the fitting plate 160 to the front to adjoin the lower side of the first rack bar 613 while the second support rib 653b is projected from the fitting plate 160 to the front to adjoin the upper side of the second rack bar 623.

[0134] Preferably, the first support rib 653a has a '∩' shaped vertical section to improve its strength and minimize friction. The second support rib 653b has a '□' shaped vertical section.

[0135] The first support rib 653a and the second support rib 653b constructed as above may be provided separately from the fitting plate 160 to be assembled into the fitting plate 160.

[0136] The support may be formed in a rotatable roller type, particularly a train wheel shaped roller type.

[0137] Meanwhile, the indoor unit of the air-conditioning system according to the present invention is preferably provided with a friction damper that minimizes friction between the door transfer unit and the cabinet 100.

[0138] The friction damper includes first and second slip ribs 661 and 662 projected at one side of the door transfer units 610 and 620 and the cabinet.

[0139] In this embodiment, the first slip rib 661 is formed at the rear side of the first transfer body 610, and the second slip rib 662 is formed at the rear side of the second transfer body 620.

[0140] More specifically, the slip ribs 661 and 662 are respectively formed at the rear side of the first door link portion 612 and the second door link portion 622.

[0141] Further, the first door link portion 612 and the

second door link portion 622 may respectively have bent portions 612a and 622a at a portion where the slip ribs 661 and 662 are formed. The bent portions 612a and 622a have a "□" shaped vertical section and are projected toward the rear.

[0142] Preferably, the slip ribs 661 and 662 are linearly in contact with the fitting plate 160 to minimize friction between the slip ribs 661 and 662 and the cabinet 100, particularly, between the slip ribs 661 and 662 and the front surface of the fitting plate 160.

[0143] The friction damper may be comprised of a roller (not shown) provided at least one side of the fitting plate 160 of the cabinet and the door transfer unit.

[0144] Meanwhile, the first transfer body 610 is preferably flush with the second transfer body 620 to minimize a space occupied by the door transfer unit.

[0145] Preferably, the door transfer unit further includes an interference preventing portion that prevents interference between the first transfer body 610 and the second transfer body 620 when the left and right outlet doors 210 and 220 are opened.

[0146] The interference preventing portion includes a first interference preventing groove 614 and a second interference preventing groove 624. The first interference preventing groove 614 is formed in the first transfer body 610 to prevent interference with the second rack bar 623. The second interference preventing groove 624 is formed in the second transfer body 620 to prevent interference with the first rack bar 613.

[0147] In more detail, the first interference preventing groove 614 is formed in the first door link portion 612 while the second interference preventing groove 624 is formed in the second door link portion 622.

[0148] In addition to the above construction, it is preferable that the indoor unit of the air-conditioning system according to the present invention further includes a door guide that guides the left and right outlet doors 210 and 220.

[0149] The door guide includes door guide grooves 671a and 671b and door guide bosses 672a and 672b. The door guide grooves 671a and 671b are formed at any one side of the left and right outlet doors 210 and 220 and the cabinet while the door guide bosses 672a and 672b are formed at the other side of the left and right outlet doors 210 and 220 and the cabinet.

[0150] In this embodiment, the first door guide groove 671a is formed at the left air outlet 101, and the second door guide groove 671b is formed at the right air outlet 102. The left outlet door 210 is provided with the first door guide boss 672a that moves along the first door guide groove 671a while the right outlet door 220 is provided with the second door guide boss 672b that moves along the second door guide groove 671b.

[0151] In more detail, the respective door guide grooves 671a and 671b are longitudinally formed at the upper edges of the left and right air outlets 101 and 102 in left and right directions. The respective door guide bosses 672a and 672b are provided at the upper portions

of the left and right outlet doors 210 and 220.

[0152] Meanwhile, the front cabinet 110 is preferably provided with a position sensor 680 that senses opening and closing of the left and right outlet doors 210 and 220.

5 **[0153]** The position sensor 680 senses the position of any one of the first transfer body 610, the second transfer body 620, the left outlet door 210 and the right outlet door 220 so that the positions of the left and right outlet doors 210 and 220 are sensed.

10 **[0154]** To this end, the position sensor 680 includes a photo sensor that senses at least one sensed portion provided at a predetermined portion of any one of the door transfer bodies 610 and 620 and the left and right outlet doors 210 and 220.

15 **[0155]** In this embodiment, the position sensor 680 senses the position of the second transfer body 620 to sense the positions of the left and right outlet doors 210 and 220. As a result, the position sensor 680 senses opening and closing of the left and right outlet doors 210 and 220.

20 **[0156]** In more detail, the photo sensor is provided at a predetermined portion of the fitting plate 160, and the sensed portion includes a first sensed body 691 and a second sensed body 692 spaced apart from the second transfer body 620 at a predetermined interval.

25 **[0157]** The photo sensor includes a light-emitting portion 681 and a light-receiving portion 682 that faces the light-emitting portion and receives light emitted from the light-emitting portion 681.

30 **[0158]** The first sensed body 691 and the second sensed body 692 are provided at the rear side of the second transfer body to pass through a space between the light-emitting portion 681 and the light-receiving portion 682 when the left and right outlet doors are opened and closed.

35 **[0159]** The first sensed body 691 is positioned between the light-emitting portion 681 and the light-receiving portion 682 when the left and right outlet doors 210 and 220 are fully closed. The second sensed body 692 is positioned between the light-emitting portion 681 and the light-receiving portion 682 when the left and right outlet doors 210 and 220 are fully opened.

40 **[0160]** Therefore, if the second transfer body 620 moves to the right to fully close the right outlet door 220, the first sensed body 691 is sensed by the position sensor 680 so that the motor 630 is stopped by a controller.

45 **[0161]** Further, if the second transfer body 620 moves to the left to fully open the right outlet door 220, the second sensed body 692 is sensed by the position sensor 680 so that the motor 630 is stopped by the controller.

50 **[0162]** The operation of the aforementioned indoor unit of the air-conditioning system according to the present invention will now be described.

55 **[0163]** First, if the power is applied to the air-conditioning system and a cooling or heating driving mode is input, the door driving gear is driven so that the left and right outlet doors 210 and 220 are simultaneously opened by horizontal movement, and the upper door 230 is also

opened.

[0164] More specifically, the left and right outlet doors 210 and 220 are transferred by the first and second transfer bodies 610 and 620, which are simultaneously transferred by rotation of the pinion gear 631, to respectively open the left and right air outlets.

[0165] At the same time, the left inlet vanes 143 and 144 are respectively opened by rotation to open the left and right air inlets 105 and 106.

[0166] The indoor air is sucked into the cabinet through the respective air inlets 104, 105 and 106 as the blower 400 is driven.

[0167] The sucked air is purged while passing through the air filters 161a and 162a and the filter assembly 163 constituting an air purging system.

[0168] In more detail, the air sucked through the front air inlet 104 of the base 130 is purged while passing through the filters 163a, 163b and 163c provided in the filter assembly 163. The air sucked through the left and right air inlets 105 and 106 is purged while passing through the air filters 161a and 162a.

[0169] Next, the air that has passed through the air filters 161a and 162a and the filter assembly 163 passes through the electric dust collector 500 positioned at the front of the blower 400. The electric dust collector 500 ionizes dust in the air and odor particles and then collects the ionized dust and the ionized odor particles.

[0170] The air purged as above is blown toward the heat exchanger 300 by the blower 400 and is discharged into the indoor through the air outlets 101, 102 and 103 in a state that it is cooled or heated by heat exchange with the refrigerant flowing inside the heat exchanger, thereby carrying out room cooling or room heating.

[0171] At this time, the left and right wind vanes 141 and 142 control the discharged air.

[0172] If the operation of the air-conditioning system is stopped, the left and right outlet doors 210 and 220 are transferred in a horizontal direction by the first and second transfer bodies 610 and 620 transferred by rotation of the pinion gear 631 and at the same time are closed.

[0173] Furthermore, the upper door 230 and the left and right inlet vanes 143 and 144 are closed by the respective driving motors to prevent foreign matters from being flown into the cabinet 100.

[0174] Meanwhile, since the left and right outlet doors 210 and 220 are opened and closed by a single motor and the upper door 230 and the inlet vanes 143 and 144 are separately driven, whether to open and close the left and right outlet doors, the upper door and the inlet vanes depends on room cooling, room heating, and the air blowing amount for air purging.

[0175] Meanwhile, if the indoor unit is mainly driven for air purging, the left and right air inlets 105 and 106 are sealed and the air is sucked through the front air inlet 104 only.

[0176] Although an air purging mode may be carried out in a state that the air outlets 101, 102 and 103 are all

opened, the left and right air outlets 101 and 102 are sealed by the left and right outlet doors 210 and 220 and the upper air outlet 103 is only opened considering balance with air suction.

[0177] Therefore, the air flown into the cabinet 100 through the front air inlet 104 is purged so that fine dust and odor particles are removed from the air while passing through the filter assembly 163 and the electric dust collector 500. Then, the air is discharged to the indoor place through the upper air outlet 103.

[0178] Now, the indoor unit of the air-conditioning system according to the second embodiment of the present invention will be described with reference to FIG. 10 to FIG. 15.

[0179] In the indoor unit of the air-conditioning system according to the second embodiment of the present invention, the other construction of the indoor unit according to the second embodiment are the same as that of the indoor unit according to the first embodiment except for the door driving gear that drives the left and right outlet doors. Therefore, the same reference numbers will be used throughout the drawings to refer to the same or like parts and their repeated description will be omitted.

[0180] Referring to FIG. 10 to FIG. 13, a door driving gear 700 provided in the indoor unit according to the second embodiment is constructed in such a manner that one of the left and right air outlets 101 and 102 is opened while the other is closed.

[0181] To this end, the door driving gear 700 includes a door transfer unit that transfers the left and right air outlets 101 and 102 in a horizontal direction.

[0182] The door transfer unit includes a transfer body 710 of which one side is connected to the left outlet door 210 and the other side is connected to the right outlet door 220.

[0183] To reciprocate the left and right outlet doors 210 and 220, the transfer body 710 is constructed in such a manner that it switches a rotational motion generated by the motor 630 provided in the driving portion to a rectilinear motion and transfers the rectilinear motion to the air outlet doors 210 and 220. However, the door transfer unit is not limited to such construction.

[0184] In detail, it is preferable that the one side and the other side of the transfer body 710, i.e., the left side and the right side of the transfer body 710 are rotatably connected to the left and right outlet doors 210 and 220, respectively. However, the transfer body 710 is not limited to such case.

[0185] To this end, at least one or more hooks 710a are provided at any one of the left outlet door 210 and the left side of the transfer body 710. At least one or more shafts 210a are provided at the other of the left outlet door 210 and the left side of the transfer body 710 and caught in the hooks 710a to form rotational shafts, so that the left outlet door 210 is rotatably connected with the transfer body 710 and at the same time the left outlet door 210 is detachably connected with the transfer body 710.

[0186] In this embodiment, a plurality of the shafts 210a are provided at the right side end of the left outlet door 210, and a plurality of the hooks 710a respectively connected to the shafts 210a are provided at the left end of the transfer body 710.

[0187] Preferably, the right outlet door 220 and the right side of the transfer body 710 are connected with each other in the same manner as the left outlet door 210 and the left side of the transfer body 710.

[0188] In other words, a plurality of shafts 220a are provided at the left end of the right outlet door 220, and a plurality of hooks 710b respectively connected to the shafts 220a are provided at the right end of the transfer body 710.

[0189] In this way, the transfer body 710 respectively connected to the left and right outlet doors 210 and 220 is preferably driven by a single motor 630.

[0190] To this end, the transfer body 710 includes a first door link portion 711, a second door link portion 712, and a rack bar 713. The first door link portion 711 is provided with the hooks 710a connected to the shafts of the left outlet door 210. The second door link portion 712 is provided with the hooks 710b connected to the shafts of the right outlet door 220. The rack bar 713 is provided between a right side of the first door link portion 711 and a left side of the second door link portion 712 to connect the first door link portion 711 with the second door link portion 712.

[0191] The rack bar 713 is provided with a rack 713a at one side. The rack 713a is preferably engaged with a pinion gear 631 rotated by the motor 630. The motor 630 is provided in the driving portion. The pinion gear 631 may directly be fixed to a shaft of the motor 630 to simplify its structure.

[0192] The door driving gear is provided with a guide that guides the door transfer unit.

[0193] An example of the guide includes guide bosses 641 and 642 and guide slots 651 and 652. The guide bosses 641 and 642 are formed at any one of the cabinet 100 and the transfer body 710. The guide slots 651 and 652 are longitudinally formed at the other of the cabinet 100 and the transfer body 710 in a transfer direction of the transfer body 710.

[0194] Referring to FIG. 11 to FIG. 13, the guide slots 651 and 652 are formed at a predetermined portion of the transfer body 710, and the guide bosses 641 and 642 are provided in the fitting plate 160.

[0195] Preferably, the guide slot 651 is respectively formed at the first door link portion 711 and the second door link portion 712 in a transfer direction of the transfer body 710.

[0196] The guide bosses 641 and 642 corresponding to the guide slots 651 and 652 are projected from the fitting plate 160 of the cabinet to the front and respectively inserted into the guide slots 651 and 652.

[0197] Therefore, the guide bosses 641 and 642 and the guide slots 651 and 652 guide the transfer body 710 in left and right directions when the transfer body 710 is

transferred in a horizontal direction.

[0198] In addition, it is preferable that the guide further includes a support that guides the door transfer unit, i.e., the transfer body 710 and at the same time prevents the transfer body 710 from being detached from the door transfer unit.

[0199] As an example of the support, there is provided a support rib 720 that supports the transfer body 710 in this embodiment.

[0200] In more detail, if the rack of the rack bar 713 is engaged with the lower side of the pinion gear, the support rib 720 is projected from the fitting plate 160 to the front to adjoin the lower side of the rack bar 713.

[0201] Preferably, the support rib 720 has a '∩' shaped vertical section to improve its strength and minimize friction.

[0202] The support rib 720 is provided to adjoin the upper side of the rack bar 713 if the rack bar 713 is provided above the pinion gear.

[0203] Meanwhile, the indoor unit of the air-conditioning system according to the present invention is preferably provided with a friction damper that minimizes friction between the door transfer unit and the cabinet 100.

[0204] The friction damper includes at least one slip rib 730 projected at one side of the transfer body 710 and the cabinet 100.

[0205] In this embodiment, the slip rib 730 is formed at the rear side of the transfer body 710.

[0206] More specifically, the slip rib 730 is respectively formed at the rear sides of the first door link portion 711 and the second door link portion 712.

[0207] Further, the first door link portion 711 and the second door link portion 712 may respectively have bent portions 711a and 712a at a portion where the slip rib 730 is formed. The bent portions 711a and 712a have a "□" shaped vertical section and are projected toward the rear.

[0208] Preferably, the slip rib 730 is linearly in contact with the fitting plate 160 to minimize friction between the slip rib 730 and the cabinet 100, particularly, between the slip rib 730 and the front surface of the fitting plate 160.

[0209] The friction damper may be comprised of a roller (not shown) provided at least one side of the fitting plate 160 of the cabinet and the door transfer unit.

[0210] Since the other construction of the second embodiment is the same as that of the first embodiment, its description will be omitted.

[0211] The indoor unit of the air-conditioning system according to the second embodiment can be operated in an opening mode of the left air outlet and an opening mode of the right air outlet.

[0212] In other words, to intensively carry out room cooling or room heating in a left place in the indoor unit, the left air outlet is opened while the right air outlet is closed.

[0213] By contrast, to intensively carry out room cooling or room heating in a right place in the indoor unit, the right air outlet is opened while the left air outlet is closed.

[0214] First, if the air-conditioning system is operated in the opening mode of the left air outlet (see FIG. 14), the pinion gear 631 is rotated in one direction to transfer the transfer body 710 to the right.

[0215] Thus, the left outlet door 210 is opened and at the same time the right outlet door 220 is closed.

[0216] The upper door 230 can selectively be opened depending on operation conditions.

[0217] The left and right inlet vanes 143 and 144 are respectively opened so that the indoor air is flown into the cabinet 100 through the air inlets 104, 105 and 106 as the blower 400 is driven.

[0218] The indoor air is purged by the air filters 161a and 162a and the filter assembly 163 while flowing into the cabinet 100 through the air inlets 104, 105 and 106 and then is again purged by the electric dust collector 500.

[0219] The purged air is cooled or heated by the heat exchanger 300, and the cooled or heated air is then discharged into the room through the left air outlet 101. If the upper air outlet 103 is opened, the cooled or heated air is also discharged through the upper air outlet 103.

[0220] Next, if the air-conditioning system is operated in the opening mode of the right air outlet (see FIG. 15), the pinion gear 631 is rotated in the other direction to transfer the transfer body 710 to the left.

[0221] Thus, the right outlet door 220 is opened and at the same time the left outlet door 210 is closed.

[0222] The upper door 230 can selectively be opened depending on operation conditions.

[0223] The left and right inlet vanes 143 and 144 are respectively opened so that the indoor air is flown into the cabinet 100 through the air inlets 104, 105 and 106 as the blower 400 is driven.

[0224] The indoor air is purged by the air filters 161a and 162a and the filter assembly 163 while flowing into the cabinet 100 through the air inlets 104, 105 and 106 and then is again purged by the electric dust collector 500.

[0225] The purged air is cooled or heated by the heat exchanger 300, and the cooled or heated air is then discharged into the room through the right air outlet 102. If the upper air outlet 103 is opened, the cooled or heated air is also discharged through the upper air outlet 103.

[0226] The indoor unit of the air-conditioning system can be operated in a state that both the left air outlet 101 and the right air outlet 102 are partially opened. In such case, the indoor unit is preferably provided with a sensor such as the aforementioned position sensor 680.

[0227] Next, the indoor unit of the air-conditioning system according to the third embodiment of the present invention will be described with reference to FIG. 16 and FIG. 17.

[0228] In the indoor unit of the air-conditioning system according to the third embodiment of the present invention, the other construction of the indoor unit according to the second embodiment are the same as that of the indoor unit according to the first embodiment except for

the wind controller that controls the wind of the air discharged through the left and right air outlets. Therefore, the same reference numbers will be used throughout the drawings to refer to the same or like parts and their repeated description will be omitted.

[0229] The wind controller provided in the indoor unit of the air-conditioning system according to the third embodiment of the present invention is constructed to change the wind of the air discharged from the left and right air outlets in up and down directions.

[0230] In more detail, the wind controller includes a plurality of left and right outlet vanes 145 and 146 respectively arranged up and down in the left and right air outlets 101 and 102.

[0231] Each of the left outlet vanes 145 provided in the left air outlet 101 is rotatably provided up and down around a rotational shaft line parallel with the base 130.

[0232] The wind controller further includes a left interlocking member 145a that interlocks the left outlet vanes 145 provided in the left air outlet 101.

[0233] The left outlet vanes 145 are interlocked by the left interlocking member 145a driven by a left vane driving motor 145b. The left vane driving motor 145b ascends the left interlocking member 145a or rotates the left outlet vane 145.

[0234] Each of the right outlet vanes 146 provided in the right air outlet 102 is rotatably provided up and down around the rotational shaft line parallel with the base 130.

[0235] The right outlet vanes 146 are interlocked by a right interlocking member 146a.

[0236] Next, the indoor unit of the air-conditioning system according to the fourth embodiment of the present invention will be described with reference to FIG. 18.

[0237] In the indoor unit of the air-conditioning system according to the fourth embodiment of the present invention, the left and right inlet vanes 143 and 144 in the first embodiment are replaced with left and right inlet grills 147 and 148. The left and right inlet grills 147 and 148 are respectively provided in the left and right air outlets 105 and 106.

[0238] Preferably, the left and right inlet grills 147 and 148 are detachably provided.

[0239] The other construction and operation principles of the indoor unit according to the fourth embodiment are the same as those of the indoor unit according to the first embodiment. Therefore, their repeated description will be omitted.

[0240] Subsequently, the indoor unit of the air-conditioning system according to the fifth embodiment of the present invention will be described with reference to FIG. 19.

[0241] Referring to FIG. 19, the indoor unit of the air-conditioning system according to the fifth embodiment of the present invention includes a left air inlet 107 and a right air inlet 108 respectively formed at the left and right slant surfaces 111b and 112b corresponding to the lower half of the front cabinet.

[0242] The left air inlet 107 and the right air inlet 108

are respectively provided with a left inlet vane (not shown) and a right inlet vane 144 that are rotatable.

[0243] Since the other construction and operation principles of the indoor unit according to the fifth embodiment are the same as those of the indoor unit according to the first embodiment, their repeated description will be omitted.

[0244] As described above, the indoor unit of the air-conditioning system according to the present invention has the following advantages.

[0245] First, in the indoor unit of the air-conditioning system according to the present invention, since the left and right air outlets are opened and closed by the movable left and right outlet doors, it is possible to prevent the left and right air outlets from being opened and closed in error due to foreign matters.

[0246] Second, in the indoor unit of the air-conditioning system according to the present invention, since the door driving gear that drives the left and right outlet doors has a simple structure, its manufacturing work is easy and the manufacturing cost is reduced.

[0247] Third, in the indoor unit of the air-conditioning system according to the present invention, since the left and right air outlets are simultaneously opened and closed, it is possible to obtain reliability of the operation.

[0248] Fourth, in the indoor unit of the air-conditioning system according to the present invention, since friction between the transfer body that transfers the left and right outlet doors and the cabinet is minimized, it is possible to desirably open and close the left and right outlet doors.

[0249] Fifth, in the indoor unit of the air-conditioning system according to the present invention, since the left and right air outlets are formed at a portion different from that of the left and right air inlets, it is possible to prevent the air discharged from the cabinet from being mixed with the air sucked into the cabinet, thereby preventing the discharged air from again flowing into the cabinet.

[0250] Sixth, in the indoor unit of the air-conditioning system according to the present invention, since the cooled or heated air is discharged from the respective air outlets in different directions, it is possible to improve indoor conditioning performance.

[0251] Finally, in the indoor unit of the air-conditioning system according to the second embodiment of the present invention, it is possible to intensively cool or heat one side of the room.

[0252] It will be apparent to those skilled in the art that various modifications and variations can be made in the present invention without departing the scope of the inventions. Thus, it is intended that the present invention covers the modifications and variations of this invention provided they come within the scope of the appended claims and their equivalents.

Claims

1. An indoor unit of an air-conditioning system compris-

ing:

a cabinet having at least one or more air inlets and air outlets and receiving a blower and a heat exchanger therein, the blower forcibly urging air flow and the air outlets being respectively formed at one side and the other side; and outlet doors movably provided in the cabinet to open and close the air outlets.

5

10

15

20

25

30

35

40

45

50

55

2. The indoor unit of an air-conditioning system according to claim 1, wherein the cabinet is provided with a door driving gear that drives the outlet doors.

3. The indoor unit of an air-conditioning system according to claim 2, wherein the door driving gear includes a door transfer unit that transfers the outlet doors, and a driving portion that drives the door transfer unit.

4. The indoor unit of an air-conditioning system according to claim 3, wherein the door transfer unit is driven by a single motor provided in the driving portion to simultaneously open and close the outlet doors.

5. The indoor unit of an air-conditioning system according to claim 2, wherein the door transfer unit switches a rotational motion generated by the driving portion to a rectilinear motion to reciprocate the outlet doors.

6. The indoor unit of an air-conditioning system according to claim 5, wherein the door transfer unit includes a first transfer body provided in the outlet door that opens and closes the air outlet formed at one side of the cabinet, and a second transfer body provided in the outlet door that opens and closes the air outlet formed at the other side of the cabinet.

7. The indoor unit of an air-conditioning system according to claim 6, wherein the first transfer body includes a first rack, and the second transfer body includes a second rack.

8. The indoor unit of an air-conditioning system according to claim 7, wherein the first and second racks are engaged with a pinion gear that is rotated by the single motor provided in the driving portion.

9. The indoor unit of an air-conditioning system according to claim 3, wherein the outlet doors are rotatably connected to the door transfer unit.

10. The indoor unit of an air-conditioning system according to claim 9, wherein the outlet doors are rotatably connected to the door transfer unit by hooks.

11. The indoor unit of an air-conditioning system according to claim 3, wherein the door driving gear further includes a guide that guides the door transfer unit.

12. The indoor unit of an air-conditioning system according to claim 11, wherein the guide includes guide bosses formed at any one of the cabinet and the door transfer unit and guide slots formed at the other of the cabinet and the door transfer unit, the guide slots being longitudinally formed in a transfer direction of the door transfer unit to insert the guide bosses therein. 5
13. The indoor unit of an air-conditioning system according to claim 11, wherein the guide includes a support that guides the door transfer unit and at the same time prevents the door transfer unit from being detached. 10
14. The indoor unit of an air-conditioning system according to claim 3, further comprising a friction damper that minimizes friction between the door transfer unit and the cabinet. 15
15. The indoor unit of an air-conditioning system according to claim 14, wherein the friction damper includes slip ribs projected at any one of the door transfer unit and the cabinet and linearly in contact with the other of the door transfer unit and the cabinet. 20
16. The indoor unit of an air-conditioning system according to claim 14, wherein the friction damper includes a roller that is provided at any one of the door transfer unit and the cabinet. 25
17. The indoor unit of an air-conditioning system according to claim 3, wherein the door transfer unit transfers the outlet doors to open any one of the air outlets and close the other of the air outlets. 30
18. The indoor unit of an air-conditioning system according to claim 17, wherein the door transfer unit includes a transfer body of which one side is connected to any one of the outlet doors and the other side is connected to the other of the outlet doors. 35
19. The indoor unit of an air-conditioning system according to claim 18, wherein the outlet doors are rotatably connected to the transfer body. 40
20. The indoor unit of an air-conditioning system according to claim 3, further comprising a position sensor that senses opening and closing of the outlet doors. 45
21. The indoor unit of an air-conditioning system according to claim 20, wherein the position sensor includes a photo sensor that senses at least one sensed portion provided at a predetermined portion of any one of the door transfer unit and the outlet doors. 50
22. The indoor unit of an air-conditioning system according to claim 2, wherein the cabinet further includes a front cover that covers the door driving gear and at least one outlet door fully opened. 55
23. The indoor unit of an air-conditioning system according to claim 1, further comprising a door guide that guides each outlet door.
24. The indoor unit of an air-conditioning system according to claim 23, wherein the door guide includes door guide grooves formed at any one of each outlet door and the cabinet, and door guide bosses at formed at the other of each outlet door and the cabinet and inserted into the door guide grooves, the door guide bosses being transferred relatively with respect to the door guide grooves when the outlet door is transferred.
25. The indoor unit of an air-conditioning system according to claim 1, wherein the air outlets are formed at left and right side portions of the cabinet.
26. The indoor unit of an air-conditioning system according to claim 25, wherein the cabinet further includes an upper air outlet formed at an upper side thereof.
27. The indoor unit of an air-conditioning system according to claim 25, wherein the air outlets are spaced apart from each other toward the rear to form a predetermined angle from a front surface of the cabinet.
28. The indoor unit of an air-conditioning system according to claim 1, further comprising a wind controller provided at the air outlets to control the wind of the air discharged through the air outlets.
29. The indoor unit of an air-conditioning system according to claim 28, wherein the wind controller changes the wind of the air discharged through the air outlets in left and right directions.
30. The indoor unit of an air-conditioning system according to claim 28, wherein the wind controller changes the wind of the air discharged through the air outlets in up and down directions.

FIG. 1

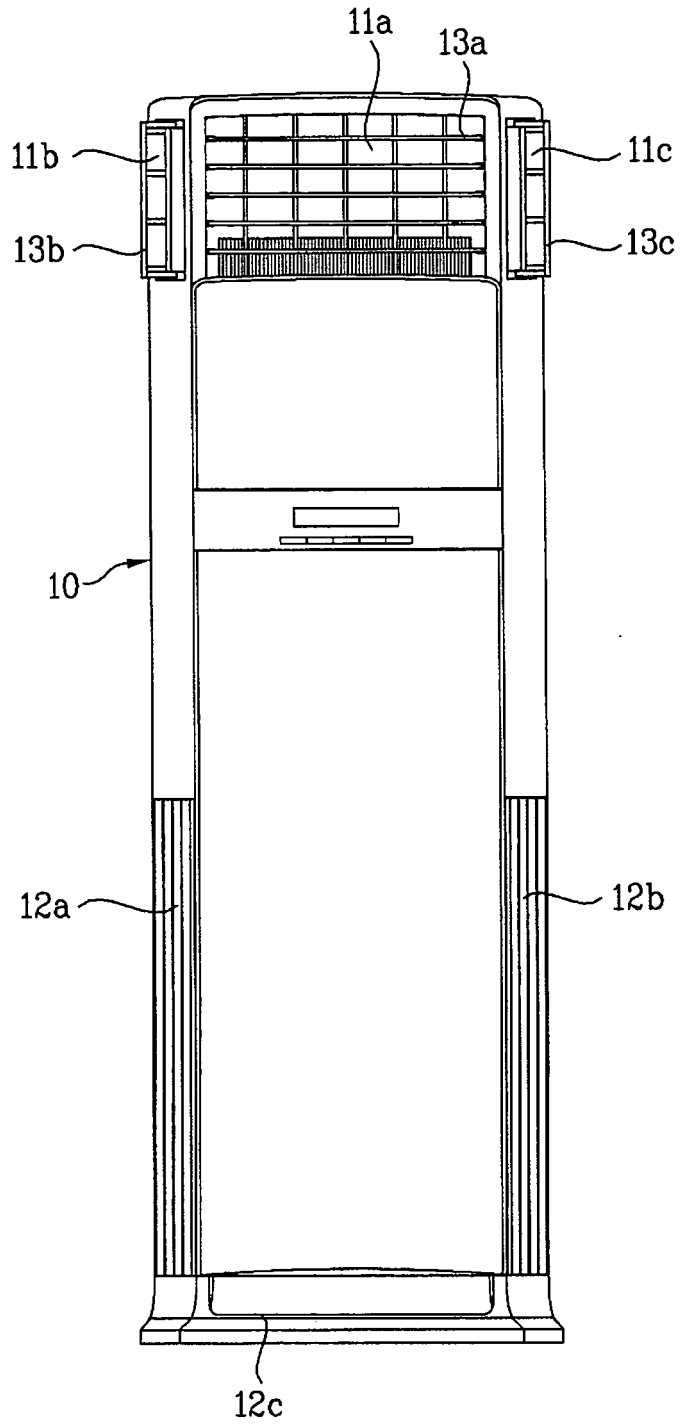

FIG. 2

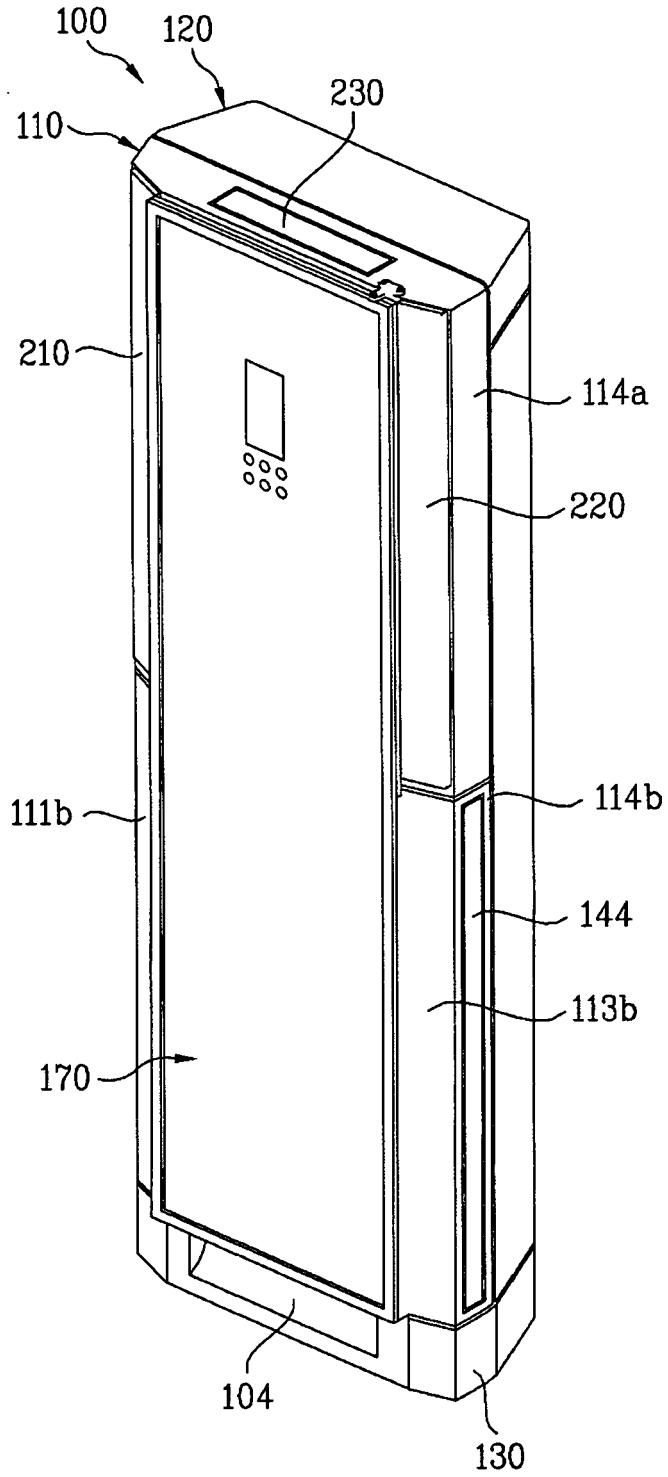

FIG. 3

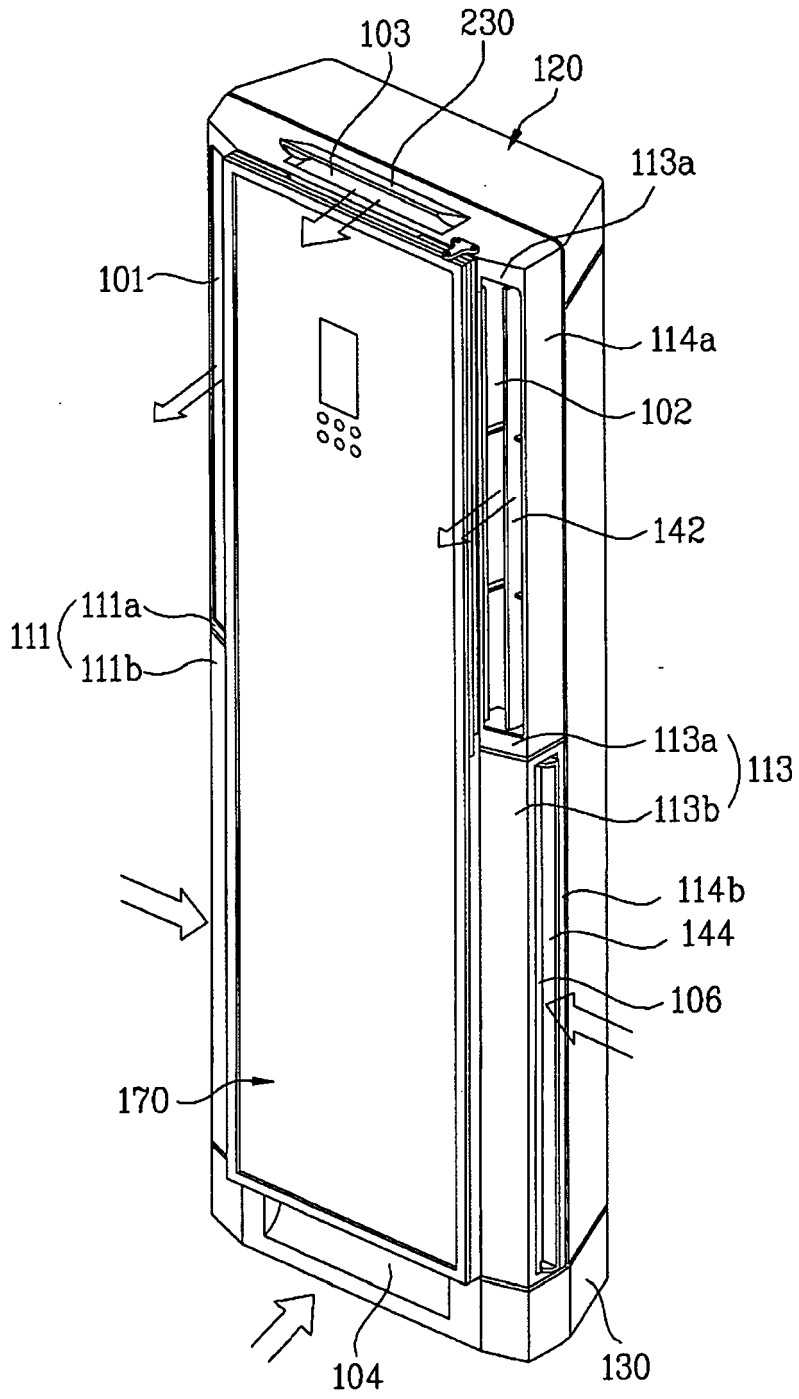

FIG. 4

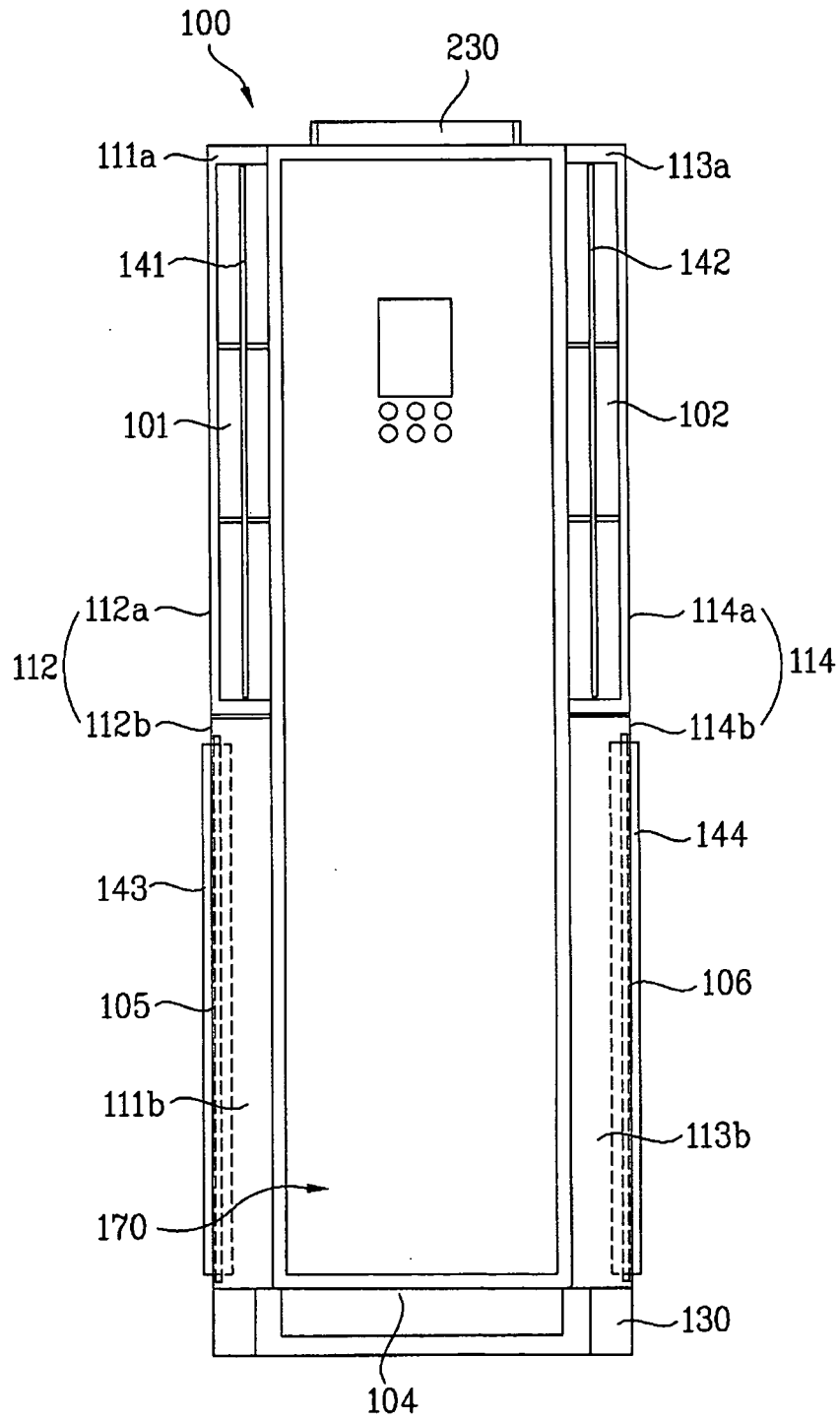

FIG. 6

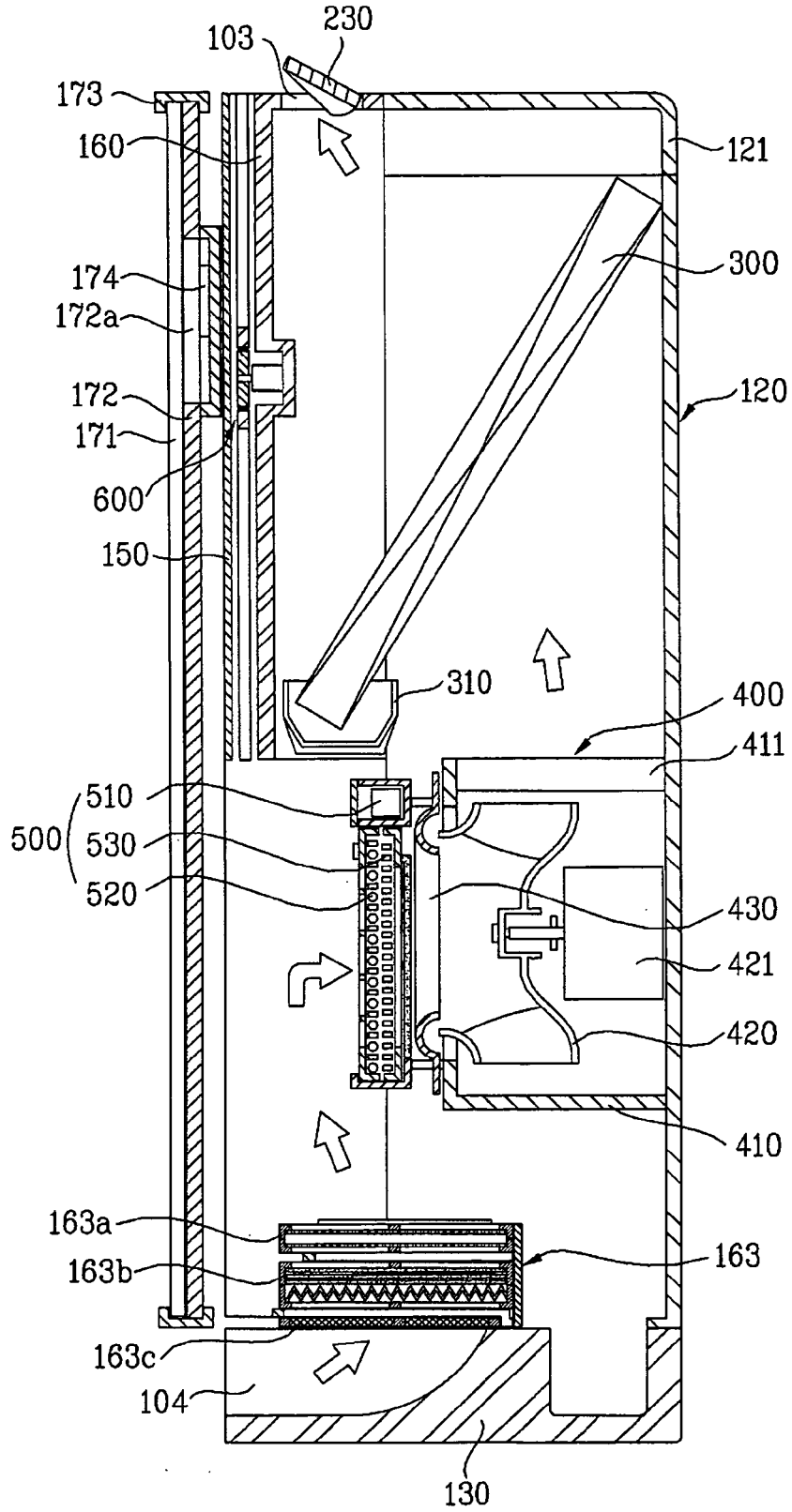

FIG. 7

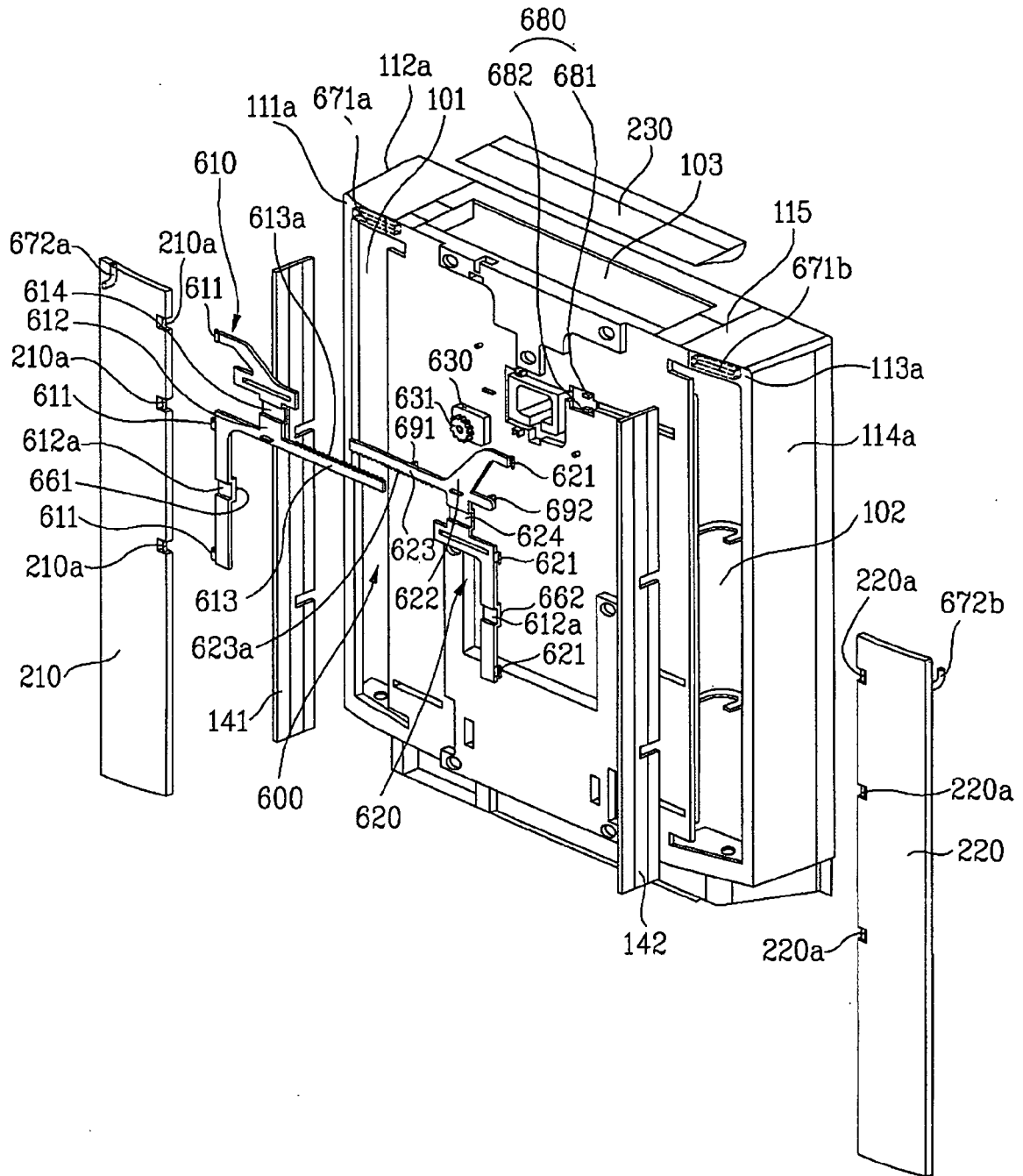

FIG. 9

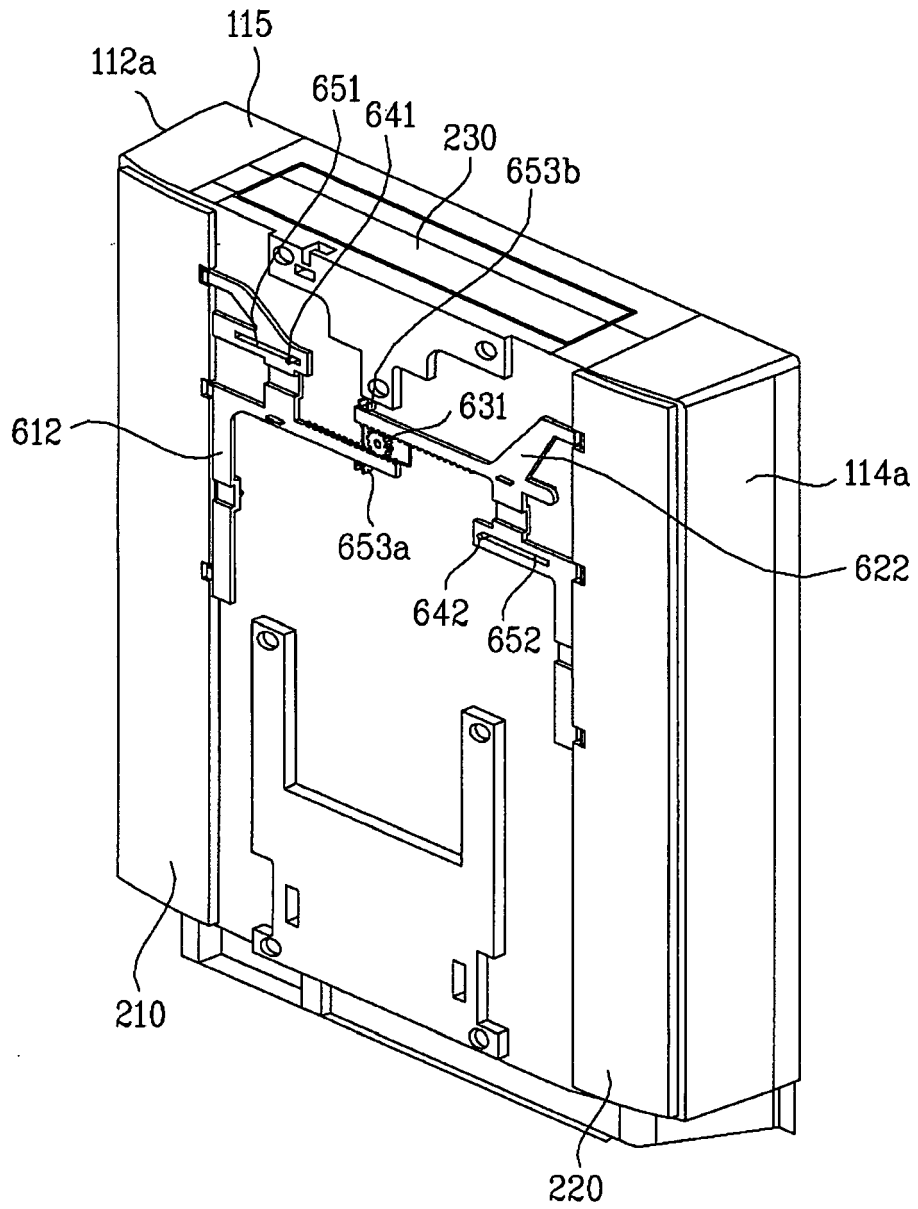

FIG. 12

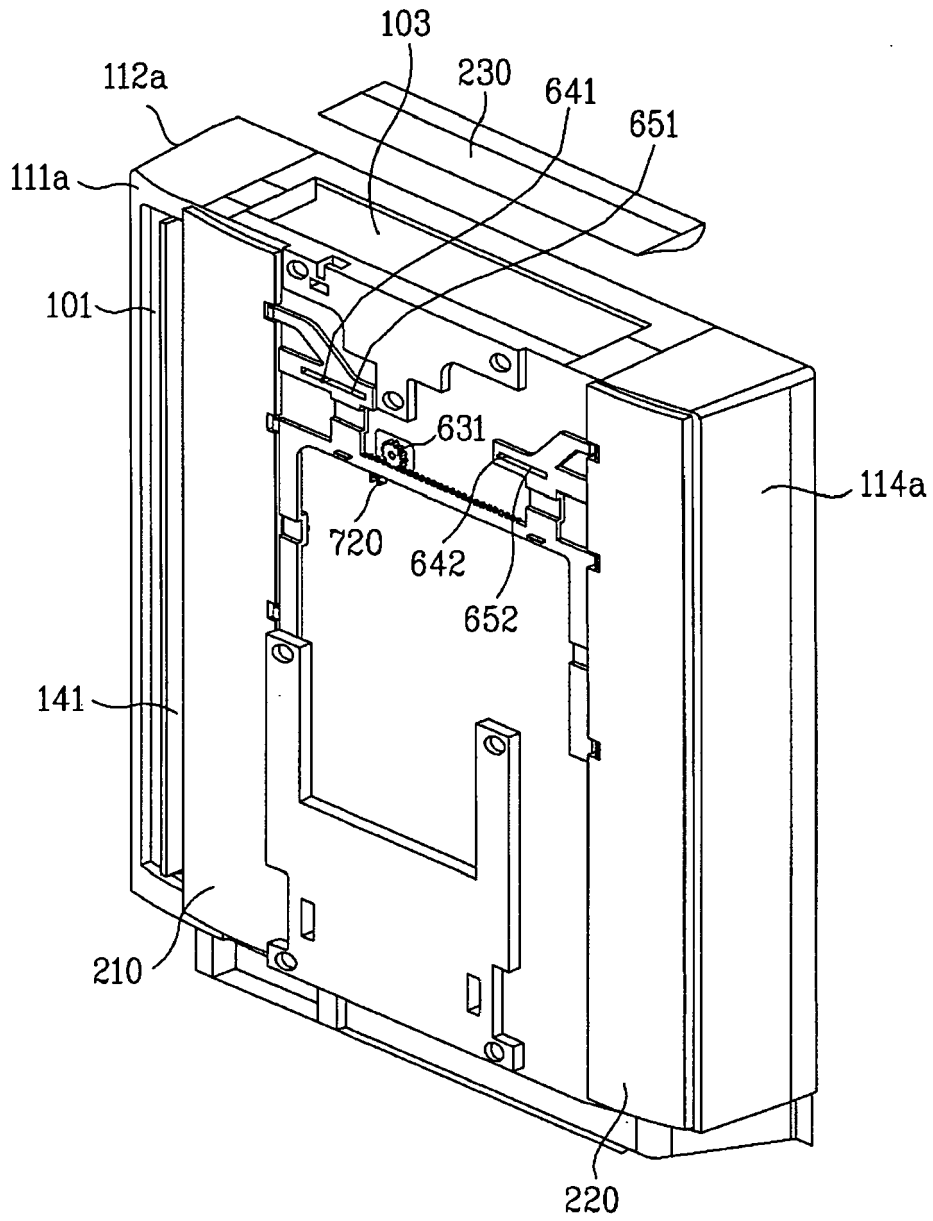

FIG. 13

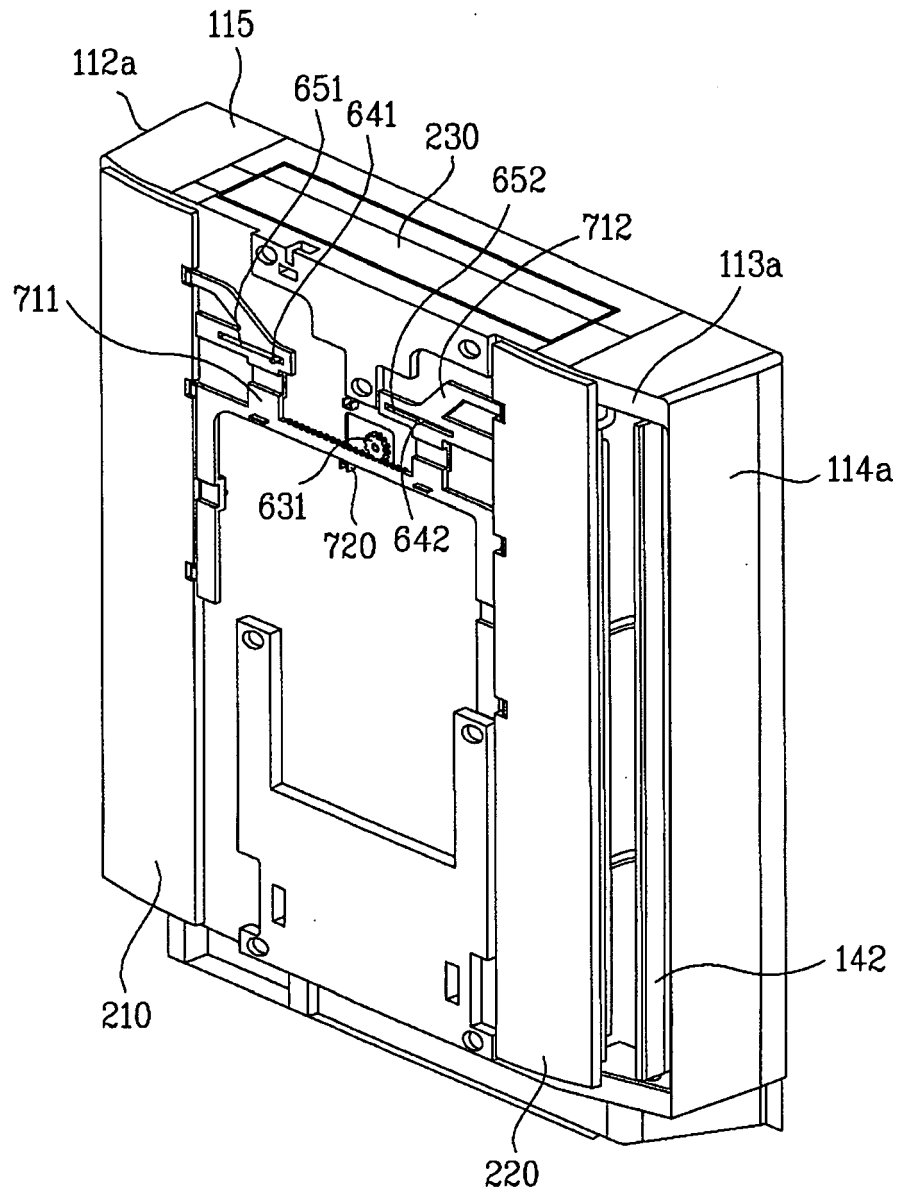

FIG. 14

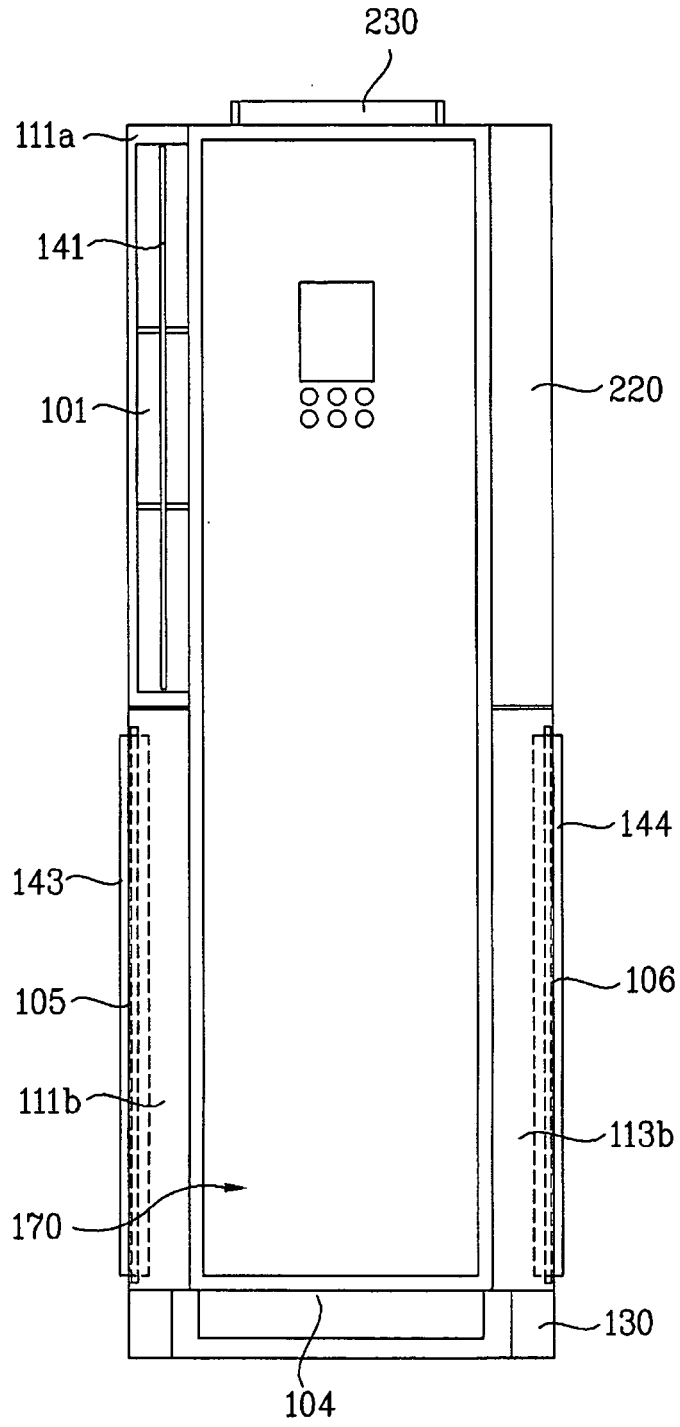

FIG. 16

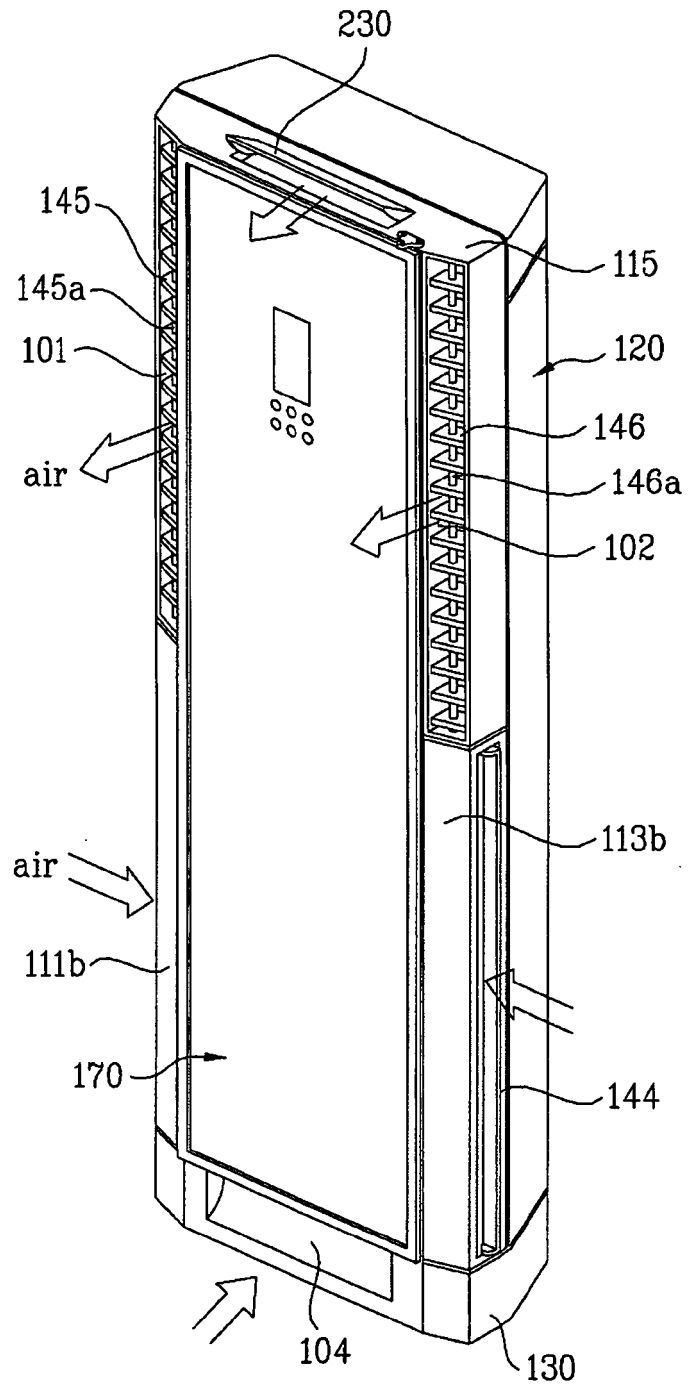

FIG. 17

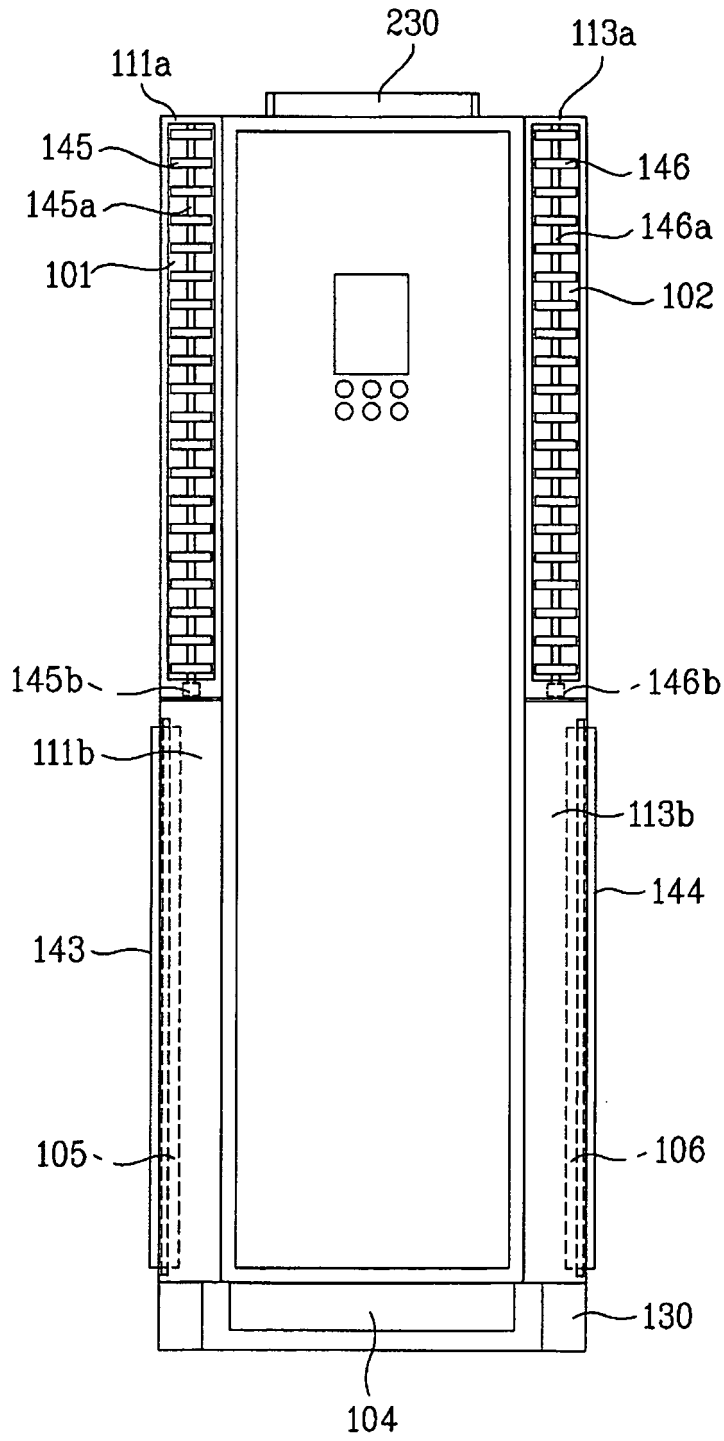

FIG. 18

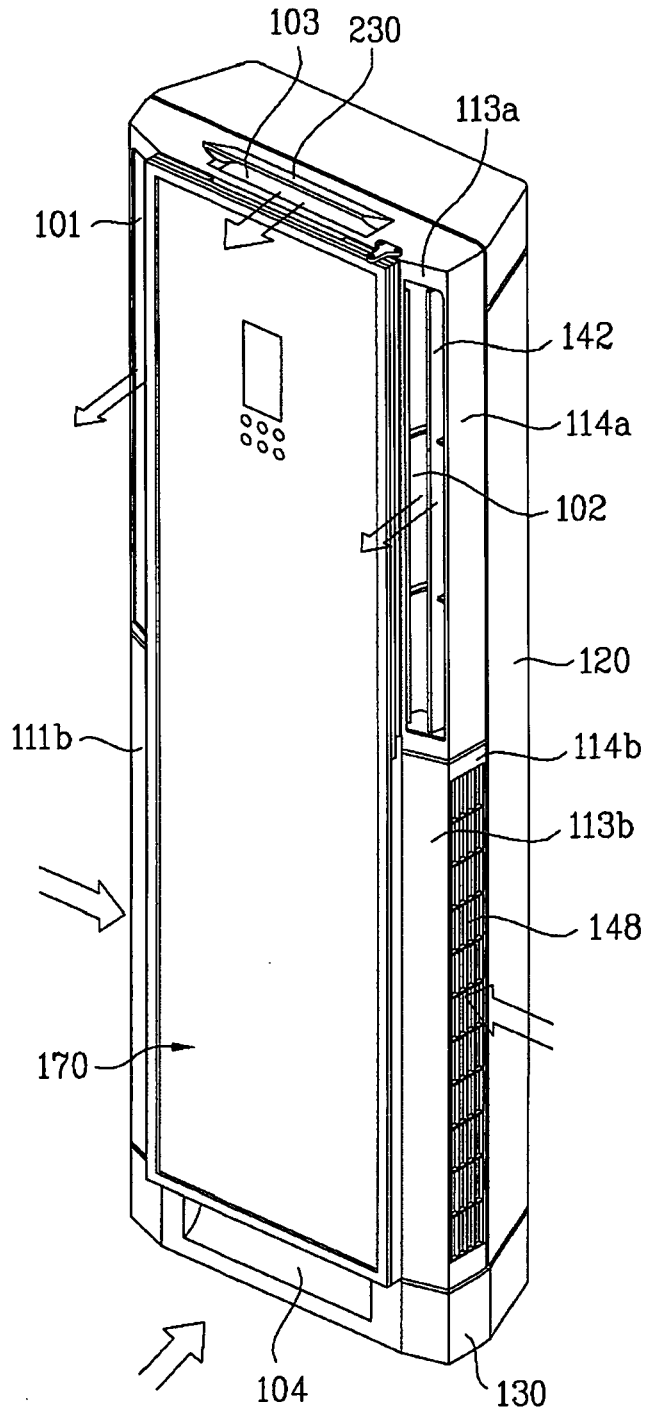
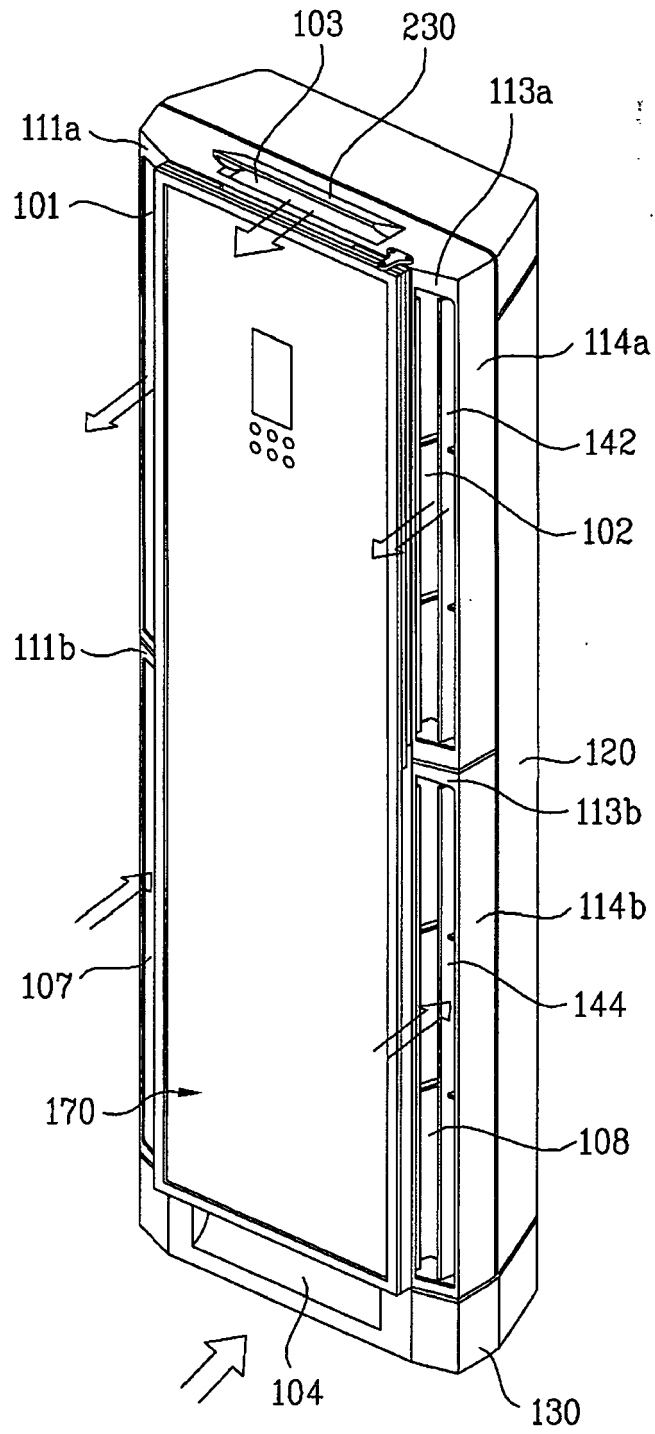

FIG. 19





DOCUMENTS CONSIDERED TO BE RELEVANT			
Category	Citation of document with indication, where appropriate, of relevant passages	Relevant to claim	CLASSIFICATION OF THE APPLICATION (IPC)
X	PATENT ABSTRACTS OF JAPAN vol. 2003, no. 12, 5 December 2003 (2003-12-05) -& JP 2003 343871 A (DAIKIN IND LTD), 3 December 2003 (2003-12-03) * abstract *	1-3, 25-28,30	F24F13/12
Y	----- US 2001/052240 A1 (KIM JONG-WHAL ET AL) 20 December 2001 (2001-12-20) * paragraphs [0032] - [0056]; figures 3,4 *	1-13, 22-28,30	
Y	----- PATENT ABSTRACTS OF JAPAN vol. 2000, no. 12, 3 January 2001 (2001-01-03) -& JP 2000 249360 A (LG ELECTRONICS INC), 12 September 2000 (2000-09-12) * abstract *	1-13, 22-28,30	
X	----- PATENT ABSTRACTS OF JAPAN vol. 1996, no. 11, 29 November 1996 (1996-11-29) & JP 08 178344 A (TOSHIBA CORP), 12 July 1996 (1996-07-12) * abstract *	1	TECHNICAL FIELDS SEARCHED (IPC) F24F
X	----- PATENT ABSTRACTS OF JAPAN vol. 004, no. 128 (M-031), 9 September 1980 (1980-09-09) & JP 55 085827 A (FUJI ELECTRIC CO LTD), 28 June 1980 (1980-06-28) * abstract *	1	
A	----- US 5 782 688 A (BAEK ET AL) 21 July 1998 (1998-07-21) * the whole document *	1	
The present search report has been drawn up for all claims			
Place of search Munich		Date of completion of the search 6 April 2006	Examiner Lienhard, D
CATEGORY OF CITED DOCUMENTS X : particularly relevant if taken alone Y : particularly relevant if combined with another document of the same category A : technological background O : non-written disclosure P : intermediate document		T : theory or principle underlying the invention E : earlier patent document, but published on, or after the filing date D : document cited in the application L : document cited for other reasons ----- & : member of the same patent family, corresponding document	

2
EPO FORM 1503 03.82 (F04C01)

**ANNEX TO THE EUROPEAN SEARCH REPORT
ON EUROPEAN PATENT APPLICATION NO.**

EP 05 25 8105

This annex lists the patent family members relating to the patent documents cited in the above-mentioned European search report. The members are as contained in the European Patent Office EDP file on
The European Patent Office is in no way liable for these particulars which are merely given for the purpose of information.

06-04-2006

Patent document cited in search report		Publication date	Patent family member(s)	Publication date
JP 2003343871	A	03-12-2003	NONE	

US 2001052240	A1	20-12-2001	CN 1329229 A	02-01-2002

JP 2000249360	A	12-09-2000	CN 1264815 A	30-08-2000
			CN 1661283 A	31-08-2005
			JP 2003156226 A	30-05-2003
			JP 2003156227 A	30-05-2003
			JP 2003114036 A	18-04-2003
			KR 2000056954 A	15-09-2000

JP 08178344	A	12-07-1996	NONE	

JP 55085827	A	28-06-1980	NONE	

US 5782688	A	21-07-1998	CN 1162725 A	22-10-1997
			ID 16276 A	18-09-1997
			JP 3011673 B2	21-02-2000
			JP 10047746 A	20-02-1998
			KR 215048 B1	16-08-1999
