



Europäisches Patentamt
European Patent Office
Office européen des brevets



(11)

EP 1 690 991 A1

(12)

EUROPEAN PATENT APPLICATION

(43) Date of publication:

16.08.2006 Bulletin 2006/33

(51) Int Cl.:

E04B 1/41 (2006.01)

E04C 2/52 (2006.01)

(21) Application number: **05075065.2**

(22) Date of filing: **13.01.2005**

(84) Designated Contracting States:

**AT BE BG CH CY CZ DE DK EE ES FI FR GB GR
HU IE IS IT LI LT LU MC NL PL PT RO SE SI SK TR**

Designated Extension States:

AL BA HR LV MK YU

(71) Applicant: **Rockwool International A/S**

2640 Hedehusene (DK)

(72) Inventor: **Pedersen, Kurt Munk**

4140 Borup (DK)

(74) Representative: **Elmeros, Claus et al**

Hoiberg A/S

St. Kongensgade 59A

1264 Copenhagen K (DK)

(54) A concrete product for a building structure

(57) The present invention concerns a concrete product (1) for a building structure, wherein at least one steel attachment rail (2) is provided at the exterior surface of the concrete product for attachment of at least one building element to the concrete product by welding. By providing attachment rails on the exterior surface of the concrete product, it becomes possible to attach building elements, such as fire insulation panels (4), anchoring

means for ventilation ducts, suspended ceilings and the like, to the concrete elements. In particular, it is found advantageous to attach a fire-retarding insulation layer without penetrating anchoring screws or the like into the concrete floors thereby risking a reduction of the strength of the concrete element, e.g. exposing the steel reinforcement to humidity, providing cracks in the hollow core structure, etc.

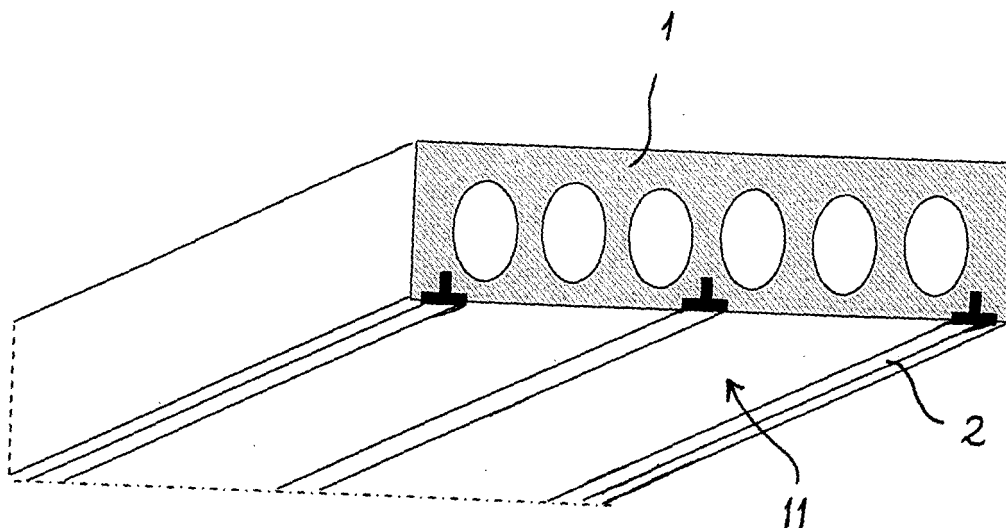

Fig. 1

EP 1 690 991 A1

Description

[0001] The present invention relates to a concrete product for a building structure, such as a reinforced concrete floor deck separating storeys in a building.

[0002] It is known to construct building structures in pre-cast concrete elements. The concrete products are typically provided with reinforcement steel bars embedded in the concrete during the casting of the concrete product. An advantage of using pre-cast concrete building elements is that they may be tailored in shape and size to the specific building construction at a relatively low production cost. On the building site, the concrete elements are assembled as the building is raised. All or some of the concrete elements may also be cast on the building site if the circumstances favour this solution. The concrete elements are constructed according to building requirements and shaped and sized to absorb the required loads. Besides saving production costs, the pre-casting of the concrete elements, floors, walls, girders, etc., e.g. off-site, may also result in a reduction of the weight of the concrete products.

[0003] In particular concrete decks may be made in hollow core concrete elements in order to reduce the weight and thereby the stress in the assemblies. The concrete floor decks are typically subjected to different loads during use of the building. In order to absorb these loads, the decks are mounted with pre-stressed reinforcement steel bars.

[0004] In many building constructions, the concrete decks must be designed for carrying various building elements, such as suspended ceilings, ventilation systems and the like, which may be mounted suspended from the concrete floor by screwing anchors into the concrete decks. This may require extra thickness of the concrete decks in order to carry the suspended load.

[0005] The concrete elements, in particular load-bearing concrete products such as concrete decks and girders, may lose the required strength if subjected to fire for a longer period of time. When exposed to fire, shearing stresses may be increased as the pre-stressed reinforcement bars expand. This may lead to a collapse of the concrete floor deck after a fire exposure of approx. 20 to 30 minutes. New building requirements concerning fire-retarding constructions are being introduced. In order to meet these requirements, the thickness of the concrete elements could be increased. However, this results in heavier concrete elements, which increased transport costs, material costs, etc. Differently sized walls, floors, etc. also requires other building construction calculations and dimensioning rules in order to satisfy the building requirements.

[0006] A way of improving the fire-retarding properties could be providing fire insulation underneath the concrete floor. However, this is uncomfortable, difficult and time consuming to mount fire insulation slabs, just as the fixation by fastening screws imposes a risk of reducing the strength of the concrete element, e.g. exposing the steel

reinforcement to damp, providing cracks in the hollow core structure, etc.

[0007] Therefore, it is an object by the present invention to provide a concrete product which can be provided with sufficient fire retarding protection whilst being relatively similar in use as the well known type of concrete products so that well-established building construction principles and experiences can be continued.

[0008] The invention consists of a concrete product for a building structure, wherein at least one steel attachment rail is provided at the exterior surface of the concrete product for attachment of at least one building element to the concrete product by welding.

[0009] The rail is a profile embedded in the surface of the product in such a manner that at least one exterior surface profile portion is exposed. By providing attachment rails on the exterior surface of the concrete product, it becomes possible to attach building elements such as fire, heat or sound insulation panels, anchoring means for ventilation ducts, suspended ceilings and the like, to the concrete elements. In particular, it is found advantageous to attach a fire-retarding insulation layer without penetrating anchoring screws or the like into the concrete floors thereby risking reducing the strength of the concrete element, e.g. exposing the steel reinforcement to damp, providing cracks in the hollow core structure, etc. Insulation panels may preferably be welded to the steel rails of the concrete product by a stud-welding technique such as described in e.g. WO 03/086697 or PCT/DK2004/000563 (not yet published).

[0010] The steel rail profiles may easily be provided during the fabrication of the concrete products. The steel rails are laid out in the bottom of the concrete cast mould, before the wet concrete is poured into the mould. Since concrete slurry may flow in underneath the rail profiles during the casting of the concrete product, the above-mentioned stud-welding techniques are particularly suitable, as these welding techniques provide a cleaning by either rotation or tapping of the metallic surface in order to establish sufficient electrical contact between the stud and the metal surface, i.e. the steel rail.

[0011] In a preferred embodiment of the invention, the insulation layer is rock wool insulation panels, preferably having a thickness of 15 - 100 mm, more preferably 20 - 75 mm, and most preferably 25 - 50 mm, and a density of preferably 30-200 kg/m³, more preferably 100 - 170 kg/m³. It is found that providing the underside of a hollow core concrete floor with 25 mm fire retarding insulation having a density of approx. 100 kg/m³, the concrete floor can withstand collapse when exposed to fire for at least one hour.

[0012] In a first embodiment, the product is a reinforced concrete deck. In particular the product may be a hollow core concrete deck, a reinforced massive concrete deck or a balloon deck. Alternatively, the concrete product according to the invention could be a reinforced concrete beam girder.

[0013] According to the preferred embodiment, a mul-

multiple of rails are provided, preferably with a substantially parallel orientation with a mutual distance of 300-600 mm. By this separation, the rails are provided with a mutual distance corresponding to the standard widths of the insulation panels. Moreover, the rails are provided at the underside of the concrete product.

[0014] Preferably, the rail profile is made of a sheet metal preferably having a thickness of 0.3 - 1.0 mm. The profile may be an inverted U-profile or inverted T-profile. The profile may be provided with retention means, such as perforations, barbed portions or the like, in order to prevent that the suspended load causes a dismounting of the profile from the concrete product.

[0015] In an embodiment, the profile may be provided with a groove rail portion, such as a dovetail groove for suspending building elements by receiving cooperating attachment means of said building elements. Hereby, building elements may be hung from the groove by suitable suspending means.

[0016] The rail profile is a galvanised steel sheet profile, or a stainless steel profile. Hereby, a corrosion resistant profile may be provided.

[0017] As an alternative to the partially embedded rail profiles in the surface of the concrete product during its casting, the rail profiles may be attached to the surface of the concrete product by attachment means, such as screws. Hereby, attachment rails may be subsequently mounted on existing building structures.

[0018] In the following the invention is described in more detail with reference to the accompanying drawings, in which:

- Fig. 1 is a schematic perspective view of a concrete slab according to an embodiment of the invention;
- Fig. 2 is a cross-section view of a concrete product according to the invention with an insulation layer mounted;
- Figs. 3 and 4 are a cross-section view of embodiments of a rail profile for a concrete product according to the invention; and
- Fig. 5 is a cross-section view of a second embodiment of the invention.

[0019] With reference to figure 1, a preferred embodiment of a concrete product according to the invention is shown. In the figure is shown a hollow core concrete slab 1, where a number of steel rail profiles 2 are provided in the surface of at the underside of the concrete deck 1.

[0020] The steel profiles 2 are provided on the exterior surface 11 of the concrete product 1, such as the underside 11 of the concrete deck 1 of figure 1. As shown in fig. 2, building elements, such as insulation panels 4 are attached to the surface-exposed steel profiles 2 of the concrete product 1 welding studs 3. The studs 3 are pinched through the insulation 4 and welded to the steel profiles 2 by a stud-welding gun (not shown) using a stud welding technique, such as described in WO 03/086697

or PCT/DK2004/000563 (not yet published).

[0021] In order to establish an electrical connection between the welding gun and the profile, the ground connection of the welding system could be provided by magnetic attachment members (not shown), which may be placed on the profile 2 during the welding process. It is also found that such magnetic grounding member could be placed on studs already attached to the profile by the welding process.

[0022] The profiles 2 are preferably embedded in the surface such that the strength of the concrete deck 1 is not affected and such that the steel reinforcement bars 5 in the concrete 1 is not brought into contact with the profiles 2. In particular in damp conditions this could otherwise cause corrosion in the reinforcement and seriously weaken the strength of the concrete product.

[0023] The steel rail profiles 2 are preferably galvanised steel or stainless steel profiles 2, which are formed by bending, extruding and/or otherwise machining a metal sheet into a T-shape, as shown in fig. 1 or a U-shape as shown in fig. 2 or other suitable shapes, for instance the profile shapes shown in figures 3 and 4.

[0024] The concrete product may be a hollow core concrete floor deck 1, as shown in figs. 1 and 2, with reinforcement steel bars 5, but may also be a massive concrete deck, a balloon deck or other concrete products, e.g. girders, etc. As shown in fig. 2, the profiles 2 are provided underneath the cavities in the hollow core concrete deck 1, so that the strength of the concrete deck is least effected as this is already the weak point in the deck design. The profiles 2 are preferably provided with a width of 30 to 70 mm and are preferably provided in the concrete product with mutual distances of e.g. 30 cm or 60 cm, so that the position of the profiles corresponds to the widths of fibrous insulation products.

[0025] It is found that a layer of fire-proof fibrous insulation 4, such as rock wool, provided on the underside of the concrete floor deck considerably improves the fire retarding properties. Moreover, it is found that insulation coating of the edge regions of the deck 2 is particularly important, e.g. around of approx. one meter of the edges of the deck, since the mounting areas of the concrete decks hereby are protected, so that the absorption of the shearing forces is not adversely affected and the floor deck remains in place. It is found that a thickness of the insulation layer of approx. 25-50 mm may provide a fire-resistance of approx. one hour, in particular if the edge regions are provided with extra thickness, e.g. of 50-100 mm insulation coating. It is of course realised that extra thickness, e.g. an insulation cover of 100 mm high density fibrous insulation may extend the fire-resistance of the concrete floor deck to more than four hours.

[0026] The required thickness of the insulation coating depends on the density of the insulation. The density may be chosen in dependence of the amount of space available underneath the deck, i.e. the ceiling height of the floor underneath. Preferably, relatively high densities of the fibrous insulation between 100 to 170 kg/m³ or even

up to 200 kg/m³ may be used. However, it is realised that fibrous insulation with densities as low as 60 kg/m³ or even as low as 30 kg/m³ could be used.

[0027] Since the insulation must be fire-proof, foam insulation materials as well as glass fibre wool is found unsuitable since these materials have melting points that are too low. The fire-resistance provided by the fibrous insulation prevents in particular the load bearing portions of the concrete deck from scaling or flaking bits of concrete when exposed to the heat of the fire for a period of time gradually reducing the strength of the deck. In order to resist the rapid loss of strength, the insulation coating proves to be an advantageous alternative to increasing the thickness of the concrete decks. By concrete decks according to the invention, a reduction of the thickness may actually be achieved without compromising the fire safety requirements of the building constructions. This is advantageous since a reduction of weight of the concrete elements in a building structure then may be achieved.

[0028] The steel profiles 2 may also be used for attaching other building elements than fibrous insulation to the concrete product. For instance, anchoring members could be welded to the profile e.g. for suspending ventilation ducts, ceilings, cables, pipes etc. from the underside of the concrete deck.

[0029] Besides welding anchoring members or the like onto the profiles 2 of the concrete products 1, the profile 2 could be provided with an integrally formed attachment groove 21, such as a profile with a dovetail groove 21 as shown in fig. 3.

[0030] The profiles 2 could be provided with retention means 22, 23 as shown in fig. 4 for preventing profiles of the underside of a concrete deck from being drawn out by the attached loads. This could be a concern if more heavy loads than insulation coatings are attached to the underside of a concrete deck. Examples of such retention means could be integrally formed edge flanges 22 and/or folded flaps 23 that are punched out in the vertical profile portions. A further way of providing retention could be to form the profile in a perforated sheet material so that the profiles are "locked" in the concrete as the wet concrete fills the perforations during the concrete product casting.

[0031] As an alternative to embedding the steel profiles in the concrete surface during the casting of the concrete product, it is realised that a steel rail profile 2 may be subsequently mounted on the concrete deck, as shown in fig. 5. Where the concrete deck elements 1' abut each other and are assembled, the flat steel profile 2 is fixed by a screw 10, which is penetrated into assembly region between the concrete slabs 1'. Hereby, it is ensured that the reinforcement bars are not damaged or exposed to the exterior.

[0032] Above, the invention has been described with reference to some preferred embodiments. However, it is realised that other embodiments such as specific concrete products may be provided and other type of steel profiles may be utilised without departing from the scope of the invention as it is defined in the accompanying

claims.

Claims

5

1. A concrete product for a building structure **characterised in that** at least one steel attachment rail is provided at the exterior surface of the concrete product for attachment of at least one building element to the concrete product by welding.

10

2. A concrete product according to claim 1, wherein the building element is a fire-retarding, heat or sound insulation layer.

15

3. A concrete product according to claim 2, wherein the insulation layer is rock wool insulation panels, preferably having a thickness of 15 - 100 mm, more preferably 20 - 75 mm, and most preferably 25 - 50 mm, and a density of preferably 30-200 kg/m³, more preferably 100 - 170 kg/m³.

20

4. A concrete product according to any of the preceding claims, wherein the product is a reinforced concrete deck.

25

5. A concrete product according to claim 4, wherein the product is a hollow core concrete deck.

30

6. A concrete product according to claim 4, wherein the product is a reinforced massive concrete deck.

35

7. A concrete product according to claim 4, wherein the product is a balloon deck.

40

8. A concrete product according to any of the claims 1 to 3, wherein the product is a reinforced concrete beam girder.

45

9. A concrete product according to any of the preceding claims, wherein a multiple of rails are provided, preferably with a substantially parallel orientation with a mutual distance of 300-600 mm.

50

10. A concrete product according to any of the preceding claims, wherein the rails are provided at the underside of the concrete product.

55

11. A concrete product according to any of the preceding claims, wherein the rails are profiles embedded in the surface of the product in such a manner that at least one exterior surface profile portion of each profile is exposed.

12. A concrete product according to any of the preceding claims, wherein the rail profile made of a sheet metal preferably having a thickness of 0.3 - 1.0 mm.

13. A concrete product according to claim 12, wherein the profile is a galvanised steel sheet profile.
14. A concrete product according to claim 12, wherein the profile is a stainless steel profile. 5
15. A concrete product according to any of the claims 12 to 14, wherein the profile is an inverted U-profile or an inverted T-profile. 10
16. A concrete product according to any of the claims 12 to 15, wherein the profile is provided with a groove rail portion, such as a dovetail groove for suspending building elements by receiving cooperating attachment means of said building elements. 15
17. A concrete product according to any of the preceding claims, wherein the at least one profile rail is attached to the surface of the concrete product by attachment means, such as screws. 20

25

30

35

40

45

50

55

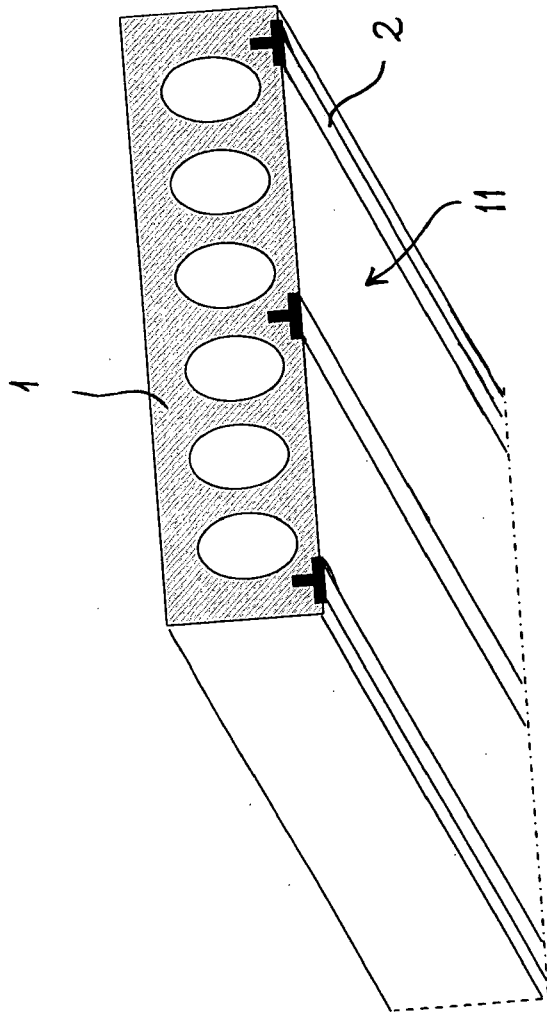

Fig. 1

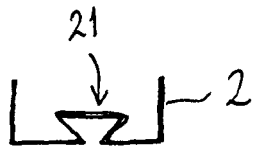
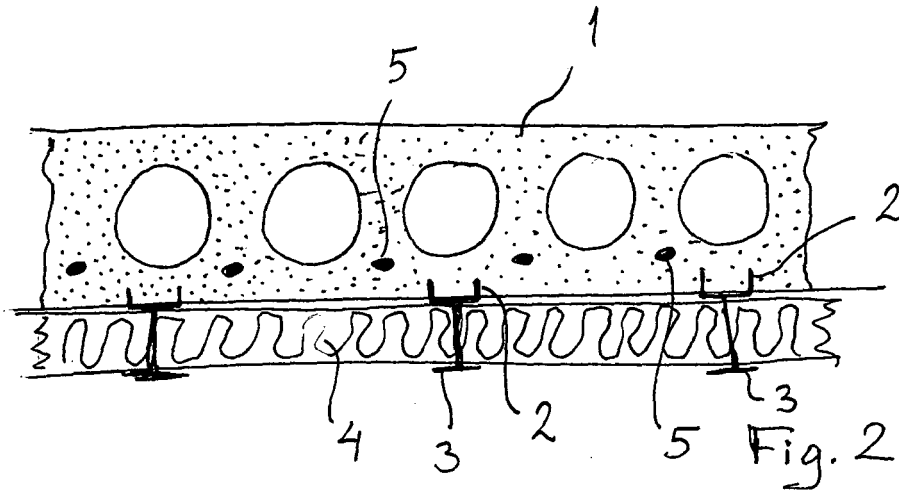

Fig. 3

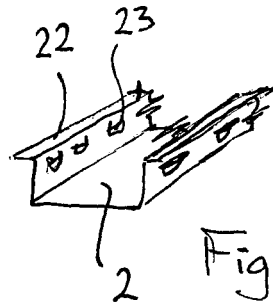

Fig. 4

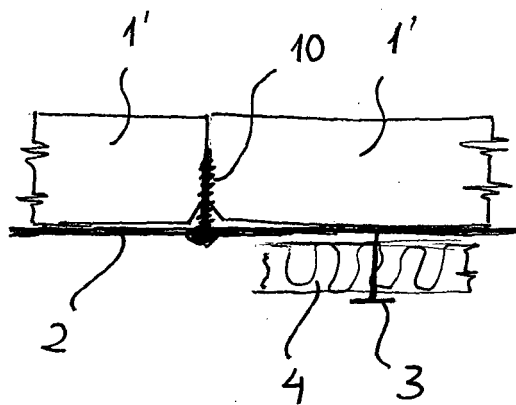

Fig. 5



DOCUMENTS CONSIDERED TO BE RELEVANT			
Category	Citation of document with indication, where appropriate, of relevant passages	Relevant to claim	CLASSIFICATION OF THE APPLICATION (Int.Cl.7)
X	DE 91 03 592 U1 (FRICKER, SIEGFRIED, 7258 HEIMSHEIM, DE) 27 June 1991 (1991-06-27)	1,10-12	E04B1/41 E04C2/52
Y	* claim 1; figure 1 *	2,3	
X	----- US 1 365 054 A (MATTHEWS WILLIAM J) 11 January 1921 (1921-01-11)	1,4,6, 9-12	
X	----- US 861 860 A (H.P.JONES) 30 July 1907 (1907-07-30)	1,8-12, 15,16	
X	----- CH 320 210 A (HOFER,OTTO) 31 March 1957 (1957-03-31)	1,16	
X	----- DE 78 17 813 U1 (SIEBAU SIEGENER STAHLBAUTEN GMBH, 5910 KREUZTAL) 25 January 1979 (1979-01-25)	1,17	
Y,D	----- WO 03/086697 A (ROCKWOOL INTERNATIONAL A/S; PEDERSEN, KURT, MUNK) 23 October 2003 (2003-10-23)	2,3	TECHNICAL FIELDS SEARCHED (Int.Cl.7) E04B E04C
The present search report has been drawn up for all claims			
Place of search Munich		Date of completion of the search 14 June 2005	Examiner Rosborough, J
CATEGORY OF CITED DOCUMENTS			
X : particularly relevant if taken alone Y : particularly relevant if combined with another document of the same category A : technological background O : non-written disclosure P : intermediate document		T : theory or principle underlying the invention E : earlier patent document, but published on, or after the filing date D : document cited in the application L : document cited for other reasons & : member of the same patent family, corresponding document	

**ANNEX TO THE EUROPEAN SEARCH REPORT
ON EUROPEAN PATENT APPLICATION NO.**

EP 05 07 5065

This annex lists the patent family members relating to the patent documents cited in the above-mentioned European search report. The members are as contained in the European Patent Office EDP file on
The European Patent Office is in no way liable for these particulars which are merely given for the purpose of information.

14-06-2005

Patent document cited in search report		Publication date	Patent family member(s)	Publication date
DE 9103592	U1	27-06-1991	NONE	

US 1365054	A	11-01-1921	NONE	

US 861860	A		NONE	

CH 320210	A	31-03-1957	NONE	

DE 7817813	U1	25-01-1979	NONE	

WO 03086697	A	23-10-2003	EP 1352699 A1	15-10-2003
			AU 2003226914 A1	27-10-2003
			WO 03086697 A1	23-10-2003
			EP 1494830 A1	12-01-2005
