



(11)

**EP 1 691 140 A1**

(12)

**EUROPEAN PATENT APPLICATION**

(43) Date of publication:  
**16.08.2006 Bulletin 2006/33**

(51) Int Cl.:  
**F24F 7/08<sup>(2006.01)</sup>** **F24F 3/044<sup>(2006.01)</sup>**  
**F24F 11/00<sup>(2006.01)</sup>** **F24F 11/02<sup>(2006.01)</sup>**

(21) Application number: **05010026.2**

(22) Date of filing: **09.05.2005**

(84) Designated Contracting States:  
**AT BE BG CH CY CZ DE DK EE ES FI FR GB GR  
HU IE IS IT LI LT LU MC NL PL PT RO SE SI SK TR**  
Designated Extension States:  
**AL BA HR LV MK YU**

- **Kim, Jeong Yong**  
**Guro-gu, Seoul (KR)**
- **Choi, Keun Hyoung**  
**Dongjak-gu, Seoul (KR)**
- **Chunk, Baik Young**  
**Yongjong-dong, Gyeyang-gu, Icheon-si (KR)**
- **Kim, Kyung Hwan**  
**Uiwang-si, Gyeonggi-do (KR)**

(30) Priority: **15.02.2005 KR 2005012319**

(71) Applicant: **LG ELECTRONICS INC.**  
**Seoul (KR)**

(74) Representative: **TER MEER - STEINMEISTER &  
PARTNER GbR**  
**Patentanwälte,**  
**Mauerkircherstrasse 45**  
**81679 München (DE)**

(72) Inventors:  
• **Choi, Ho Seon**  
**Dongjak-gu, Seoul (KR)**

(54) **Ventilation system and control method therefor**

(57) A ventilation system and a pressure intensifying apparatus can smoothly supply air to an indoor room by increasing required air volume and external static pressure. The ventilation system includes: a duct branched into at least rooms; a ventilator connected to the duct,

for selectively or simultaneously exhausting indoor air and supplying outdoor air; and a pressure intensifying apparatus including a case in which air supply unit/air exhaust unit connected to the duct are formed, and a fan for increasing static pressure of air supplied/exhausted through the duct.

**FIG. 1**

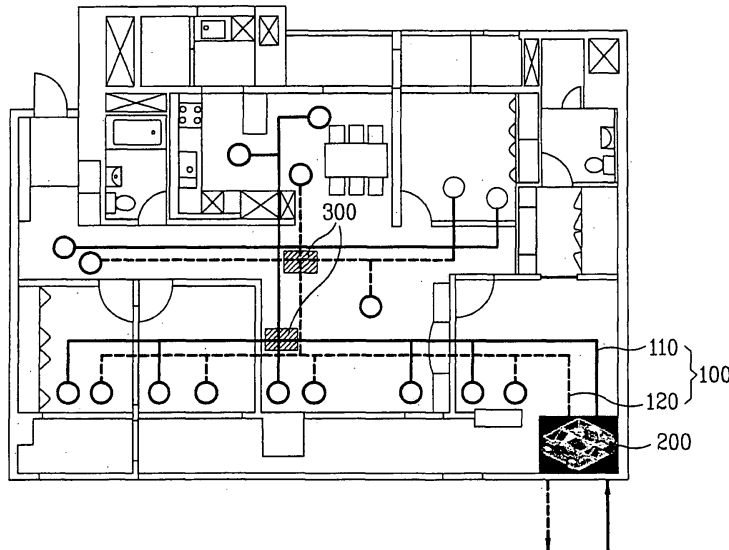

**EP 1 691 140 A1**

**Description****BACKGROUND OF THE INVENTION****Field of the Invention**

[0001] The present invention relates to a ventilation system, and more particularly, to a ventilation system, a pressure intensifying apparatus, and a method for controlling the same, in which air volume and external static pressure can be increased.

**Discussion of the Related Art**

[0002] Due to persons' breathes and the like, air in the closed room is gradually polluted with the lapse of time. A ventilation system is used to replace polluted indoor air with fresh outdoor air.

[0003] A general ventilation system includes an air supply fan for supplying an outdoor air into a room, an air supply duct for guiding an outdoor air into the room, an air exhaust fan for exhausting an indoor air out of the room, and an air exhaust duct for guiding the indoor air out of the room.

[0004] In order to supply air into the room through the duct, the ventilation system must have required air volume and external static pressure. For example, when air is supplied through a circular duct in an about 231-m<sup>2</sup> indoor space by ventilation of 350 CMH, an external static pressure of about 300 Pa is required. At this point, airflow resistance of a duct is an important factor in determining the required air volume and external static pressure. As the indoor space is wide, a length of the duct becomes longer. As the number of the partitioned spaces is increasing, the branches of the duct increase. Consequently, the airflow resistance increases and the required air volume and external static pressure increases. However, it is difficult to increase a capacity of the ventilation system so large as to form sufficient air volume and external static pressure. Thus, the ventilation is not performed smoothly.

[0005] Also, the general ventilation system is installed in a ceiling. However, since the ventilation system is designed considering spatial efficiency and economic efficiency, there is a limit in a distance between a bottom of a lower floor and a bottom of an upper floor. Thus, it is difficult to secure sufficient space for installing the ventilation system. Accordingly, in order to solve the problem, the ventilation system needs to be designed to be small-sized.

**SUMMARY OF THE INVENTION**

[0006] Accordingly, the present invention is directed to a ventilation system and a pressure intensifying apparatus that substantially obviate one or more problems due to limitations and disadvantages of the related art.

[0007] An object of the present invention is to provide

a ventilation system, a pressure intensifying apparatus, and a method for controlling the same, in which external static pressure is formed so high that a wide indoor space can be ventilated.

5 [0008] Another object of the present invention is to provide a small-sized ventilation system and a pressure intensifying apparatus, which can be installed in a narrow space.

10 [0009] Additional advantages, objects, and features of the invention will be set forth in part in the description which follows and in part will become apparent to those having ordinary skill in the art upon examination of the following or may be learned from practice of the invention. The objectives and other advantages of the invention may be realized and attained by the structure particularly pointed out in the written description and claims hereof as well as the appended drawings.

15 [0010] To achieve these objects and other advantages and in accordance with the purpose of the invention, as embodied and broadly described herein, there is provided a ventilation system including: a duct branched into at least rooms; a ventilator connected to the duct, for selectively or simultaneously exhausting indoor air and supplying outdoor air; and a pressure intensifying apparatus including: a case in which air supply unit/air exhaust unit connected to the duct are formed; and a fan for intensifying static pressure of air supplied/exhausted through the duct.

20 [0011] The pressure intensifying apparatus may include: at least two air supply units and at least two air exhaust units connected to the duct; a fan disposed inside the case, for supply/exhaust air by rotation thereof; and a drive motor disposed inside the case, for rotating the fan. The pressure intensifying apparatus may further include a damper for opening/closing the air supply unit and the air exhaust unit.

25 [0012] The case may be formed evenly, and the air supply unit and the air exhaust unit may be arranged at a periphery of the case. The case may have top and bottom surfaces formed in a circular shape. Also, the case may be installed in a ceiling.

30 [0013] The air supply unit and the air exhaust unit may be inclined with respect to a rotational radius of the fan. The air supply unit may further include a damper for opening/closing to guide air sucked inside the case in an axial direction of the fan.

35 [0014] The pressure intensifying apparatus may be arranged in a position where the duct is branched. The duct may include an air supply duct and an air discharge duct. The pressure intensifying apparatus may be installed in each of the air supply duct and the air exhaust duct.

40 [0015] The ventilation system may further include a controller for controlling the ventilator and/or the pressure intensifying apparatus according to user's input information.

45 [0016] In another aspect of the present invention, there is provided a pressure intensifying apparatus including: at least two branched ducts; a case divided into an upper

space and a lower space; an air supply unit and an air exhaust unit for communicating the upper and lower spaces of the case with the duct; a fan disposed inside the case, for sucking air through the air supply unit and exhausting air through the air exhaust unit, or for sucking air through the air exhaust unit and exhausting air through the air supply unit; and a drive motor, disposed inside the case, for rotating the fan.

[0017] The case may be formed evenly, and at least two air supply units and at least two air exhaust units may be arranged at a periphery of the case.

[0018] The fan may be configured to suck air in an axial direction and exhaust air in a radial direction. The fan may be a double suction fan having an air supply fan and an air exhaust fan arranged up and down, the air supply fan being configured to suck air toward in an inside of the case through the air supply unit and exhaust the sucked air to the air exhaust unit, the air exhaust fan being configured to suck air through the air exhaust unit and exhaust the sucked air to the air supply unit.

[0019] The air supply unit may further include: an air supply damper for opening/closing to guide air sucked inside the case in an axial direction; and an air exhaust damper for opening/closing to guide air exhausted from the fan toward the duct. The air supply damper may include a first air supply damper for guiding air sucked in the air supply unit in an axial direction of the fan, and a second air supply damper for preventing air from being exhausted to the air supply unit when the first air supply damper, and the air exhaust damper includes a first air exhaust damper for guiding air exhausted from the fan to the air exhaust unit, and a second air exhaust damper for preventing air from being sucked into the fan. The air exhaust damper and the air supply damper may alternately open the air supply unit and the air exhaust unit.

[0020] The case may be separated into a space where the air supply fan is received and a space where the air exhaust fan is received.

[0021] In a further another aspect of the present invention, there is provided a method for controlling a ventilation system, including the steps of: selecting a predetermined input information; driving a ventilator; driving a pressure intensifying apparatus so as to increase an inner pressure of a duct connected to the ventilator; and increasing a static pressure of the duct by opening a damper, the damper being openable/closable according to the input information and provided at a position where the pressure intensifying apparatus and the duct are connected.

[0022] In a still further another aspect of the present invention, there is provided a method for controlling a pressure intensifying apparatus, including the steps of: selecting a predetermined input information; rotating a fan of a pressure intensifying apparatus, the fan being provided to increase an inner pressure of a duct; and increasing a static pressure of the duct by opening a damper, the damper being openable/closable according to the input information and provided at a position where

the pressure intensifying apparatus and the duct are connected.

[0023] It is to be understood that both the foregoing general description and the following detailed description of the present invention are exemplary and explanatory and are intended to provide further explanation of the invention as claimed.

### **BRIEF DESCRIPTION OF THE DRAWINGS**

[0024] The accompanying drawings, which are included to provide a further understanding of the invention and are incorporated in and constitute a part of this application, illustrate embodiment(s) of the invention and together with the description serve to explain the principle of the invention. In the drawings:

[0025] FIG. 1 is a schematic view for explaining a ventilation system according to an embodiment of the present invention;

[0026] FIG. 2 is a view of a pressure intensifying apparatus shown in FIG. 1;

[0027] FIG. 3 is a perspective view of the pressure intensifying apparatus shown in FIG. 2;

[0028] FIG. 4 is a side view illustrating an operation of the pressure intensifying apparatus shown in FIG. 2;

[0029] FIG. 5 is a graph of a relationship between an air volume and an external static pressure in the ventilation system shown in FIG. 1;

[0030] FIG. 6 is a perspective view of a pressure intensifying apparatus according to a second embodiment of the present invention;

[0031] FIG. 7 is a side view illustrating an operation of the pressure intensifying apparatus shown in FIG. 6 when air is guided from an air supply unit to an air exhaust unit; and

[0032] FIG. 8 is a side view illustrating an operation of the pressure intensifying apparatus shown in FIG. 6 when air is guided from an air exhaust unit to an air supply unit.

### **DETAILED DESCRIPTION OF THE INVENTION**

[0033] Reference will now be made in detail to the preferred embodiments of the present invention, examples of which are illustrated in the accompanying drawings. Wherever possible, the same reference numbers will be used throughout the drawings to refer to the same or like parts.

[0034] FIG. 1 is a view for explaining a ventilation system according to an embodiment of the present invention.

[0035] Referring to FIG. 1, the ventilation system includes a duct 100 spatially branched into at least two indoor spaces, a ventilator 200 connected to the duct 100 to selectively or simultaneously exchange indoor air with outdoor air through the duct 100, and a pressure intensifying apparatus 300 having a fan (320 in FIG. 2) for increasing a static pressure of air supplied/exhausted through the duct 100.

[0036] The duct 100 is branched such that the indoor

air is exchanged with outdoor air in the partitioned indoor spaces. The duct 100 includes an air supply duct 110 for supplying the outdoor air into the indoor spaces, and an air exhaust duct 120 for exhausting the indoor air to an exterior. The ventilation system installed in a wide indoor space is exemplarily shown in FIG. 1. The air supply duct 110 is indicated by a solid line and the exhaust duct 120 is indicated by a dotted line. An air supply diffuser and an air exhaust diffuser are connected to indoor end portions of the air supply duct 110 and the air exhaust duct 120, respectively. In FIG. 1, the diffusers are indicated by circles. Meanwhile, the duct may be configured with only one of the air supply duct and the air exhaust duct.

**[0037]** Also, the ducts 110 and 120 can be circular or polygonal. Because the pressure intensifying apparatus 300 increases a static pressure in the duct 100, the polygonal duct having a relatively large airflow resistance can be used. It is apparent that the circular duct is advantageous to reduce airflow resistance. Such a duct is buried in a ceiling.

**[0038]** The ventilator 200 includes a total heat exchanger (not shown) for exchanging heat between the indoor air and the outdoor air, and a blower fan (not shown) for blowing the indoor air and the outdoor air. The total heat exchanger may not be installed in the ventilator 200. Also, it is preferable to install a filter (not shown) that filters out foreign particles contained in the supplied outdoor air.

**[0039]** In addition, it is preferable to install the pressure intensifying apparatus 300 in the air supply duct 110 and the air exhaust duct. It is apparent that the pressure intensifying apparatus 300 can be installed in only one of the air supply duct and the air exhaust duct. Further, it is preferable that the pressure intensifying apparatus 300 is buried in a ceiling. It is also apparent that two or more pressure intensifying apparatuses can be respectively installed in the air supply duct and the air exhaust duct.

**[0040]** The pressure intensifying apparatus will now be described with reference to FIGs. 2 to 4.

**[0041]** The pressure intensifying apparatus 300 includes a case 310 installed in the ducts 110 and 120, air supply units 311 connected to the ducts 110 and 120 to guide air of at least the ducts 110 and 120 into the case 310, air exhaust units 312 for guiding an inside air of the case 310 to the ducts 110 and 120, a fan 320 installed inside the case 310 to rotate to supply/exhaust air, and a drive motor 330 for rotating the fan 320.

**[0042]** It is preferable that the case 310 is formed evenly. Also, it is preferable that at least two air supply units 311 and at least two air exhaust units 312 are provided at a periphery of the case 310. The case 310 is formed evenly for the purpose of enabling it to be buried. Also, the air supply unit 311 and the air exhaust unit 312 are provided at the periphery of the case for the purpose of enabling the branched ducts 110 and 120 to be connected from all directions.

**[0043]** For example, the case 310 has top and bottom surfaces formed in a circular shape. On the periphery of

the case 310, the air supply unit 311 and the air exhaust duct 312 are formed spaced apart from each other at predetermined intervals. It is apparent that the case 310 can be made in a polygonal shape. The case 310 having the top and bottom surfaces formed in the circular shape is advantageous to reduce airflow resistance.

**[0044]** As shown in FIG. 4, the fan 320 may be a turbo fan 320 that sucks air in an axial direction and discharges air in a radial direction. The turbo fan 320 includes a plurality of blades 321 radially arranged and a donut-shaped shroud 322 fixed to one side (an upper side in FIG. 3) of the blade 321. Accordingly, the sucked air passes through the central portion of the shroud 322 and is then discharged in the radial direction as the blades 321 are rotating. A high static pressure is formed inside the case 310, such that air is discharged.

**[0045]** Because the turbo fan 320 is advantageous to increase the static pressure, the turbo fan 320 is installed so as to increase the static pressure in the duct 100. If the turbo fan 320 is used, the height of the case 310 is lowered, such that the pressure intensifying apparatus can be easily buried in the ceiling.

**[0046]** As shown in FIG. 2, it is preferable that the air supply unit 311 and the air exhaust unit 312 are inclined by a predetermined angle ( $\theta$ ) with respect to a rotational radius of the turbo fan 320. It aims to reduce airflow resistance because the supplied/exhausted air flows obliquely with respect to the rotational radius of the fan 320.

**[0047]** The pressure intensifying apparatus 300 may further include dampers 340 and 350 for opening/closing the air supply unit 311 and the air exhaust unit 312. When the damper 340 disposed at the air supply unit 311 is opened, air sucked inside the case 310 is guided in an axial direction (toward an upper portion) of the turbo fan 320. As shown in FIG. 4, the damper 340 is installed to be rotatable about a lower end thereof. Accordingly, in the case of the damper 340, a separate guide for guiding air in the axial direction of the turbo fan 320 need not be installed.

**[0048]** The ventilator 200 and/or the pressure intensifying apparatus 300 may further include a controller (not shown) for controlling it depending on user's input information. The controller (not shown) for the pressure intensifying apparatus 300 controls the static pressure of air passing through the intensifying apparatus 300 by selectively opening/closing the damper 340 depending on the input information.

**[0049]** The pressure intensifying apparatus 300 can be applied to gas circulating devices, such as a ventilation system and an air conditioner.

**[0050]** An operation of the ventilation system and the pressure intensifying apparatus according to the present invention will now be described.

**[0051]** A ventilation mode is started according to a user's selection. At this point, an air supply stroke and an air exhaust stroke can be done at the same time, or only one stroke of them can be done. The former case will be described below.

**[0052]** When the ventilator 200 operates, an outdoor air flows along the air supply duct 110 and a polluted indoor air flows along the air exhaust duct 120 due to pressure of the ventilator 200. The static pressure in the duct is greatly reduced due to airflow resistance generated while the indoor and outdoor air flows through the ducts 110 and 120.

**[0053]** In such a state, as shown in FIG. 4, the pressure intensifying apparatus 300 opens the dampers 340 and 350 such that air flowing through the ducts 110 and 120 is distributed to the branched ducts. At this point, the damper 340 disposed at the air supply unit 311 is opened in an inclined manner such that an upper portion of the air supply unit 311 is opened.

Accordingly, air introduced in the air supply unit 311 is guided toward the central portion of the turbo fan 320 by the damper 340.

**[0054]** As the turbo fan 320 rotates, the guided air flows in a radial direction. This operation of the turbo fan 320 causes airflow pressure to increase greatly in the inner periphery of the case 310. Accordingly, air discharged through the air exhaust unit 312 is in a state of very high pressure and is exhausted to the ducts 110 and 120 connected to the air exhaust unit 312. Consequently, the static pressure in the ducts 110 and 120 can increase greatly.

**[0055]** FIG. 5 is a graph of a test result when the pressure intensifying apparatus 300 is installed in an about 231-m<sup>2</sup> indoor space. When the pressure intensifying apparatus 300 is not installed, the static pressure in the ducts 110 and 120 is about 170 Pa (L<sub>1</sub>). On the contrary, when the pressure intensifying apparatus 300 is installed, the static pressure in the ducts 110 and 120 is about 300 Pa (L<sub>2</sub>), which is two times as high as the former case. Accordingly, the pressure intensifying apparatus 300 can supply/exhaust sufficient air to/from the indoor space.

**[0056]** FIGs. 6 to 8 are views of a pressure intensifying apparatus 400 according to a second embodiment of the present invention.

**[0057]** The pressure intensifying apparatus 400 includes a case 410, an air supply unit 411, an air exhaust unit 412, an air supply fan 420, and an air exhaust fan 430. The case 410 is installed in at least two branched ducts 110 and 120 and is divided into an upper space and a lower space. The air supply unit 411 and the air exhaust unit 412 communicate the upper and lower spaces of the case 410 with the ducts 110 and 120. The air supply fan 420 and the air exhaust fan 430 are installed inside the case 410 and are coaxially connected with a drive motor 440.

**[0058]** The case 410 has top and bottom surfaces formed in a circular shape. On the periphery of the case 410, the air supply unit 411 and the air exhaust unit 412 are formed spaced apart from each other at predetermined intervals. The case 310 having the top and bottom surfaces formed in the circular shape is advantageous to reduce the airflow resistance. Also, an entire height of the case 410 can be reduced.

**[0059]** The air supply fan 420 sucks air through the air supply unit 411 and exhausts it to the air exhaust unit 412. The air exhaust fan 412 sucks air through the air exhaust unit 412 and exhausts it to the air supply unit 411. It is preferable that the fans 420 and 430 are a double suction fan in which the air supply fan 420 and the air exhaust fan 430 are coaxially connected to the drive motor 440.

**[0060]** The case 410 is partitioned to separate the spaces where the air supply fan 420 and the air exhaust fan 430 are installed.

**[0061]** The air supply unit 411 includes a first air supply damper 451 for guiding the sucked air in an axial direction of the air supply fan 420, and a second air supply damper 461 for preventing the air from being exhausted from the air exhaust fan 430 to the air supply unit 411 when the first air supply damper 451 is opened. The air exhaust unit 412 includes a first air exhaust damper 452 for guiding the air exhausted from the air supply fan 420 to the air exhaust unit 412 toward the air exhaust duct 120, and a second air exhaust damper 462 for preventing air from being sucked to the air exhaust fan 430 when the first air exhaust damper 452.

**[0062]** As shown in FIGs. 6 or 7, the air supply dampers 451 and 461 and the air exhaust dampers 452 and 462 are installed up and down such that they are rotatable about a partition plate that separates the air supply fan 420 and the air exhaust fan 430. Also, the first air supply damper 451 is opened in an inclined manner such that an upper surface of the air supply fan 420 is opened. The second air supply damper 462 is opened in an inclined manner such that a lower portion of the air exhaust fan 430 is opened. Accordingly, if the dampers 451 and 462 are applied, a separate guide for guiding air in an axial direction of the fan need not be installed.

**[0063]** In the operation of the air supply dampers 451 and 461 and the air exhaust dampers 452 and 462, when the first air supply damper 451 and the first air exhaust damper 452 are opened, the air supply fan 420 operates to increase the static pressure of air supplied from the air supply unit 411 to the air exhaust unit 412. When the second air exhaust damper 462 and the second air supply damper 461 are opened, the air exhaust fan 430 operates to increase the static pressure of air supplied from the air exhaust unit 412 to the air supply unit 411. At this point, the dampers can be selectively opened/closed.

**[0064]** As described above, in the case of the double suction fan, the static pressure of the ducts 110 and 120 can be increased at the same time by installing the pressure intensifying apparatus 400 in the intersection between the air supply duct 110 and the air exhaust duct 120, not in each of the air supply duct and the air exhaust duct 120.

**[0065]** Also, the air supply dampers 451 and 461 and the air exhaust dampers 452 and 462 are selectively opened and closed, such that the connection between the air supply unit 411 and the duct 110 and between the air exhaust unit 412 and the duct 120 can be modified.

Also, air volume provided to the ducts 110 and 120 can be changed.

**[0066]** It will be apparent to those skilled in the art that various modifications and variations can be made in the present invention. Thus, it is intended that the present invention covers the modifications and variations of this invention provided they come within the scope of the appended claims and their equivalents.

## Claims

### 1. A ventilation system comprising:

a duct branched into at least rooms;  
 a ventilator connected to the duct, for selectively or simultaneously exhausting indoor air and supplying outdoor air; and  
 a pressure intensifying apparatus including:  
 a case in which air supply unit/air exhaust unit connected to the duct are formed; and  
 a fan for increasing static pressure of air supplied/exhausted through the duct.

### 2. The ventilation system of claim 1, wherein the pressure intensifying apparatus includes:

at least two air supply units and at least two air exhaust units connected to the duct;  
 a fan disposed inside the case, for supply/exhaust air by rotation thereof; and  
 a drive motor disposed inside the case, for rotating the fan.

### 3. The ventilation system of claim 1, wherein the pressure intensifying apparatus further includes a damper for opening/closing the air supply unit and the air exhaust unit.

### 4. The ventilation system of claim 1, wherein the case is formed evenly, and the air supply unit and the air exhaust unit are arranged at a periphery of the case.

### 5. The ventilation system of claim 1, wherein the case has top and bottom surfaces formed in a circular shape.

### 6. The ventilation system of claim 1, wherein the case is installed in a ceiling.

### 7. The ventilation system of claim 1, wherein the fan is a turbo fan that sucks air in an axial direction and exhausts air in a radial direction.

### 8. The ventilation system of claim 1, wherein the air supply unit and the air exhaust unit are inclined with respect to a rotational radius of the fan.

### 9. The ventilation system of claim 8, wherein the air supply unit further includes a damper for opening/closing to guide air sucked inside the case in an axial direction of the fan.

### 10. The ventilation system of claim 1, wherein the pressure intensifying apparatus is arranged in a position where the duct is branched.

### 11. The ventilation system of claim 1, wherein the duct includes an air supply duct and an air discharge duct.

### 12. The ventilation system of claim 11, wherein the pressure intensifying apparatus is installed in each of the air supply duct and the air exhaust duct.

### 13. The ventilation system of claim 1, further comprising a controller for controlling the ventilator and/or the pressure intensifying apparatus according to user's input information.

### 14. A pressure intensifying apparatus comprising:

at least two branched ducts;  
 a case divided into an upper space and a lower space;  
 an air supply unit and an air exhaust unit for communicating the upper and lower spaces of the case with the duct;  
 a fan disposed inside the case, for sucking air through the air supply unit and exhausting air through the air exhaust unit, or for sucking air through the air exhaust unit and exhausting air through the air supply unit; and  
 a drive motor, disposed inside the case, for rotating the fan.

### 15. The pressure intensifying apparatus of claim 14, wherein the case is formed evenly, and at least two air supply units and at least two air exhaust units are arranged at a periphery of the case.

### 16. The pressure intensifying apparatus of claim 14, wherein the fan is configured to suck air in an axial direction and exhaust air in a radial direction.

### 17. The pressure intensifying apparatus of claim 14, wherein the fan is a double suction fan having an air supply fan and an air exhaust fan arranged up and down, the air supply fan being configured to suck air toward in an inside of the case through the air supply unit and exhaust the sucked air to the air exhaust unit, the air exhaust fan being configured to suck air through the air exhaust unit and exhaust the sucked air to the air supply unit.

### 18. The pressure intensifying apparatus of claim 14, wherein the air supply unit further includes:

an air supply damper for opening/closing to guide air sucked inside the case in an axial direction; and  
 an air exhaust damper for opening/closing to guide air exhausted from the fan toward the duct. 5

**19.** The pressure intensifying apparatus of claim 18, wherein the air supply damper includes a first air supply damper for guiding air sucked in the air supply unit in an axial direction of the fan, and a second air supply damper for preventing air from being exhausted to the air supply unit when the first air supply damper, and  
 the air exhaust damper includes a first air exhaust damper for guiding air exhausted from the fan to the air exhaust unit, and a second air exhaust damper for preventing air from being sucked into the fan. 10  
 15

**20.** The pressure intensifying apparatus of claim 19, wherein the air exhaust damper and the air supply damper alternately open the air supply unit and the air exhaust unit. 20

**21.** The pressure intensifying apparatus of claim 14, wherein the case is separated into a space where the air supply fan is received and a space where the air exhaust fan is received. 25

**22.** A method for controlling a ventilation system, comprising the steps of: 30

selecting a predetermined input information;  
 driving a ventilator;  
 driving a pressure intensifying apparatus so as to increase an inner pressure of a duct connected to the ventilator; and 35  
 increasing a static pressure of the duct by opening a damper, the damper being openable/closable according to the input information and provided at a position where the pressure intensifying apparatus and the duct are connected. 40

**23.** A method for controlling a pressure intensifying apparatus, comprising the steps of: 45

selecting a predetermined input information;  
 rotating a fan of a pressure intensifying apparatus, the fan being provided to increase an inner pressure of a duct; and  
 increasing a static pressure of the duct by opening a damper, the damper being openable/closable according to the input information and provided at a position where the pressure intensifying apparatus and the duct are connected. 50  
 55

FIG. 1

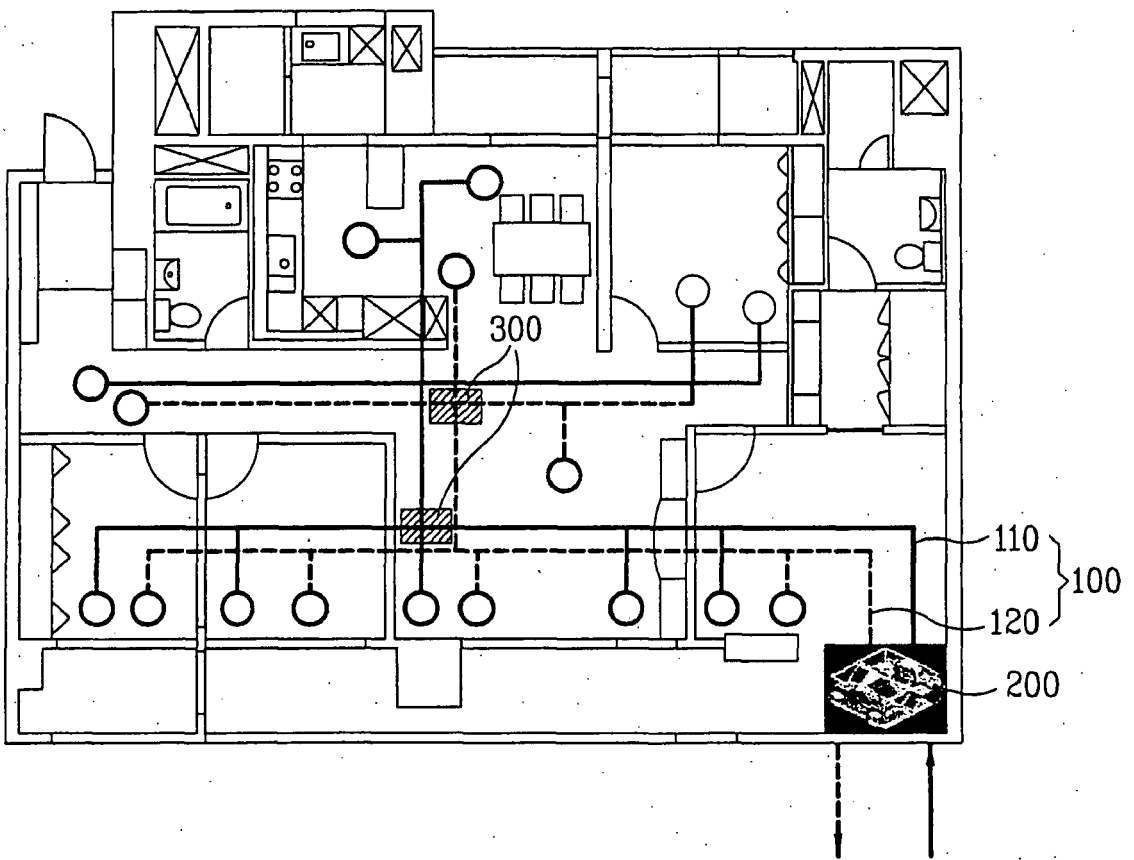

FIG. 2

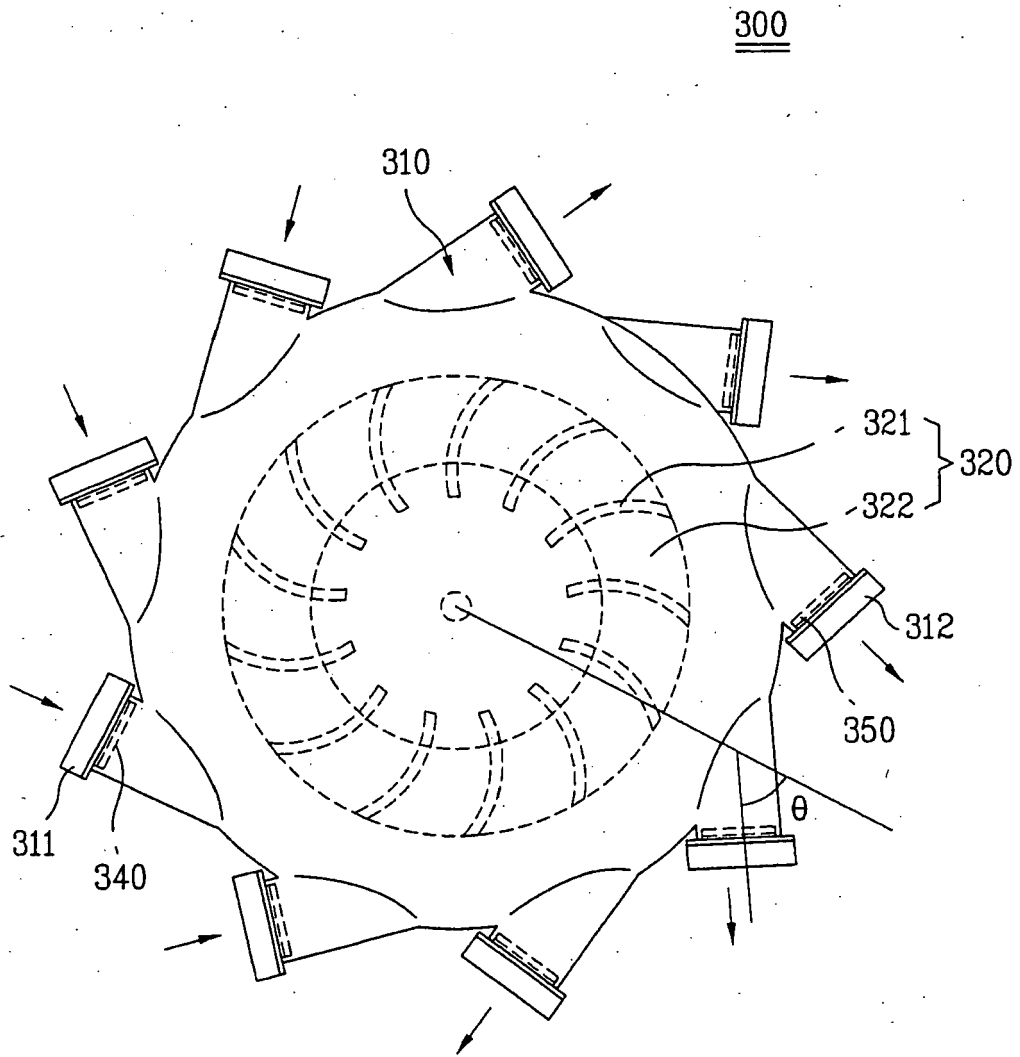

FIG. 3

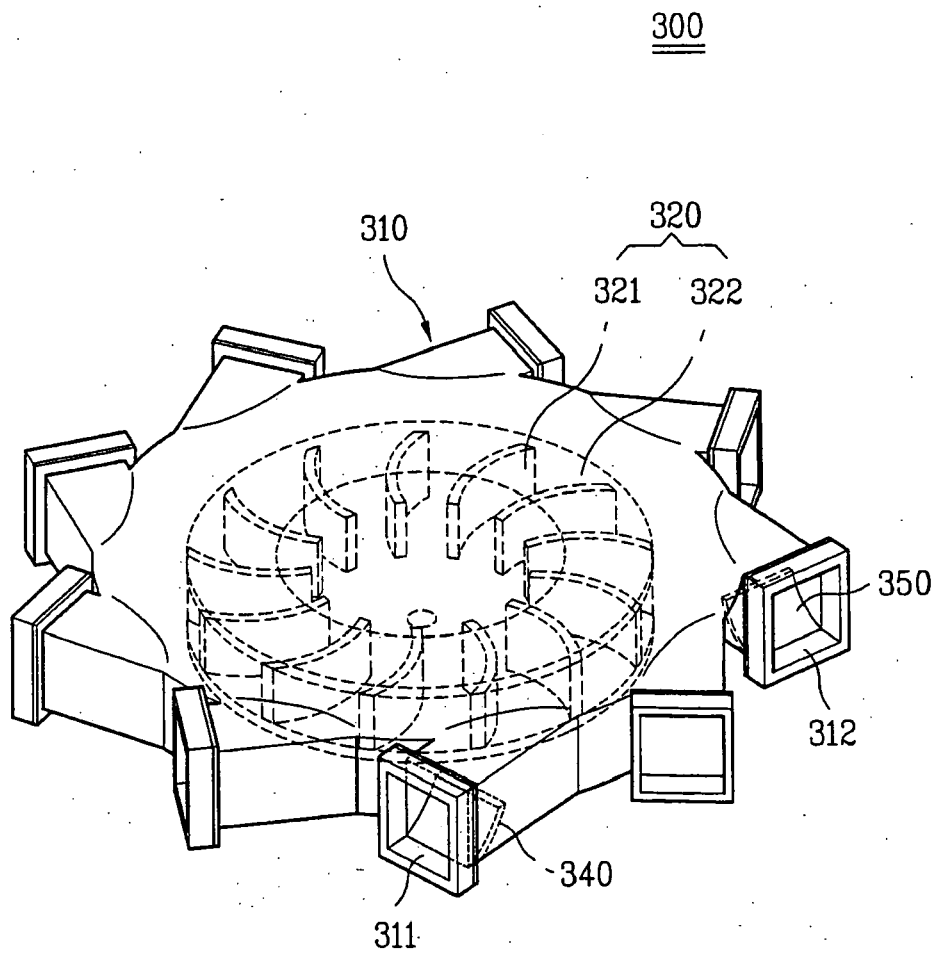

FIG. 4

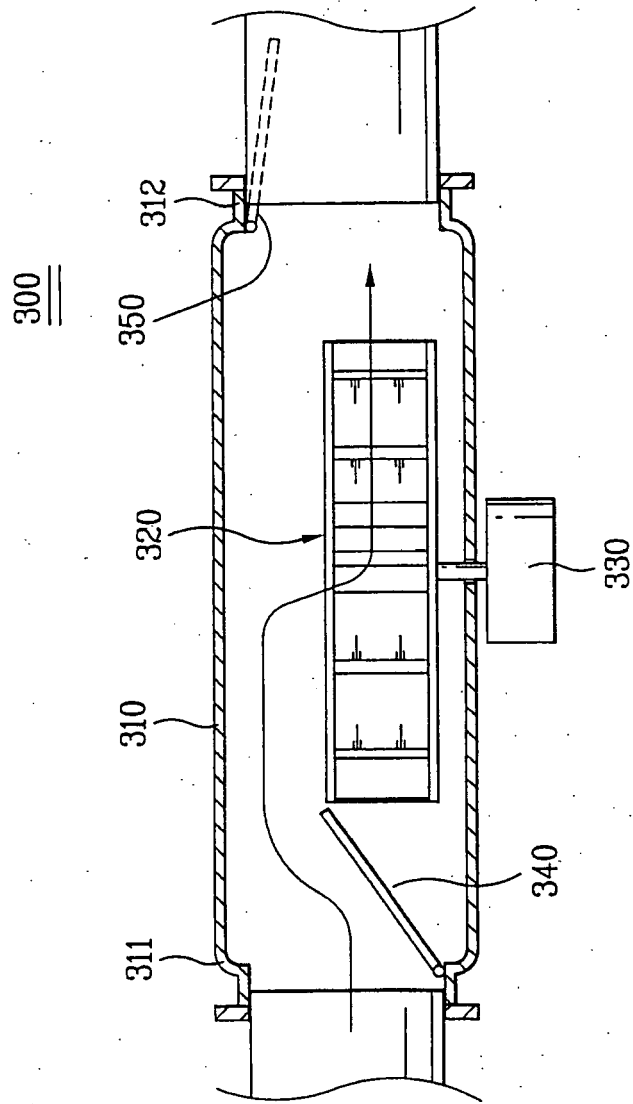

FIG. 5

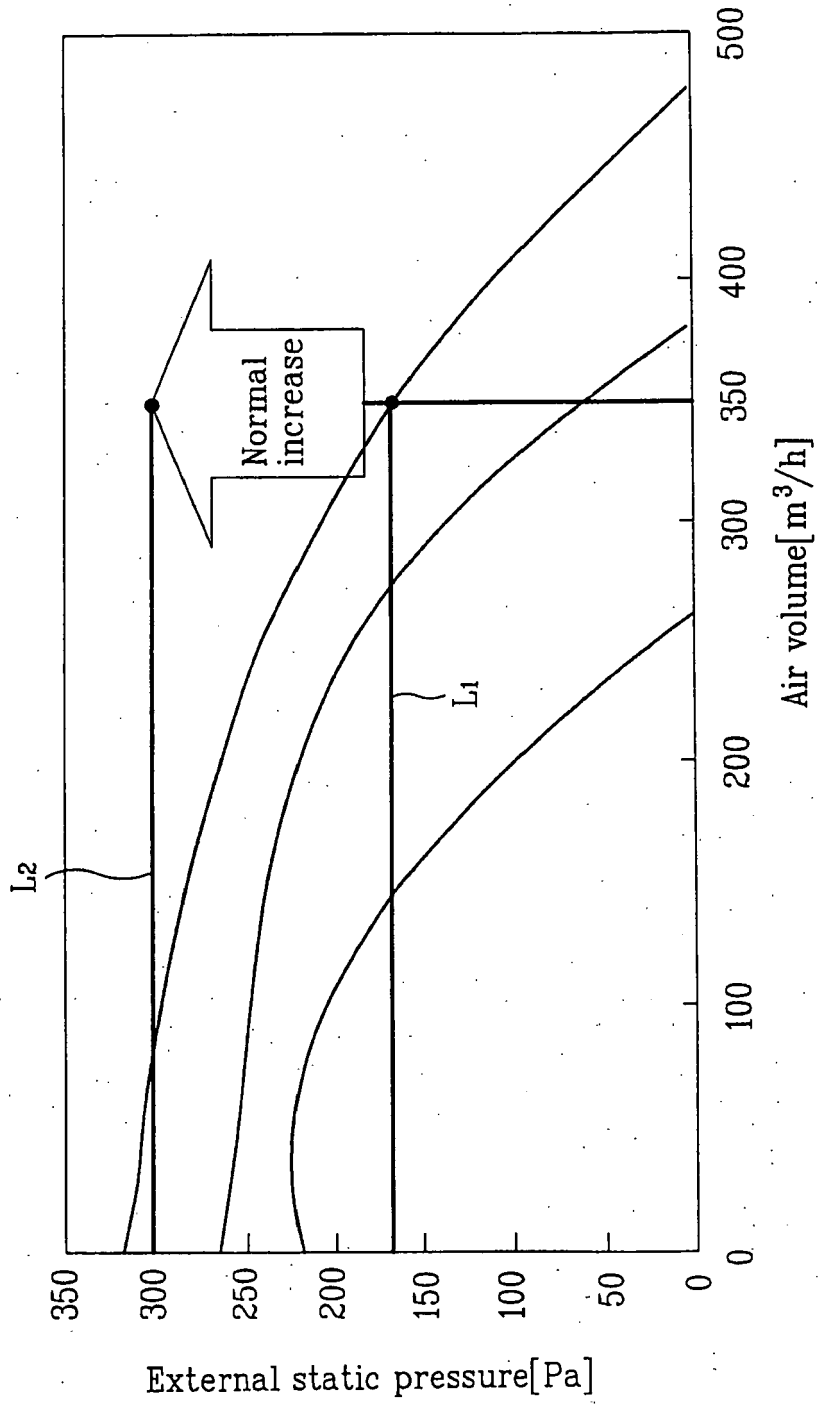

FIG. 6

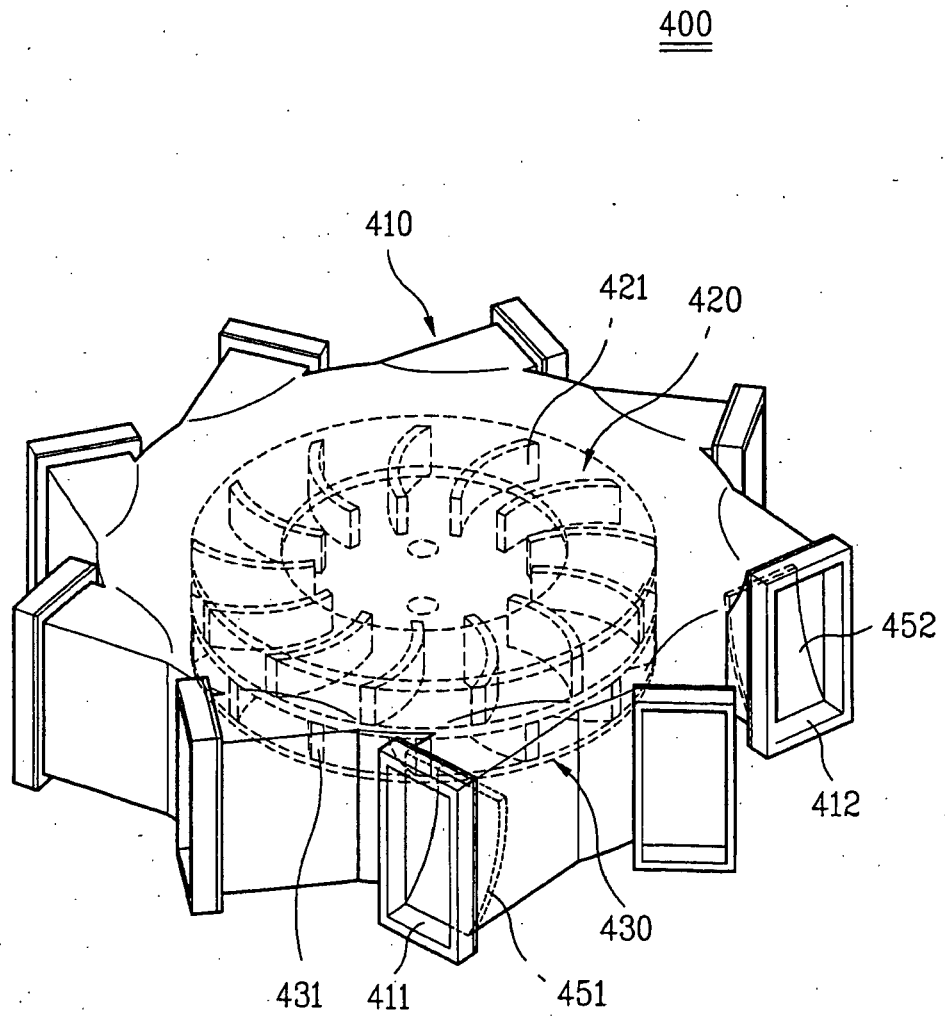

FIG. 7

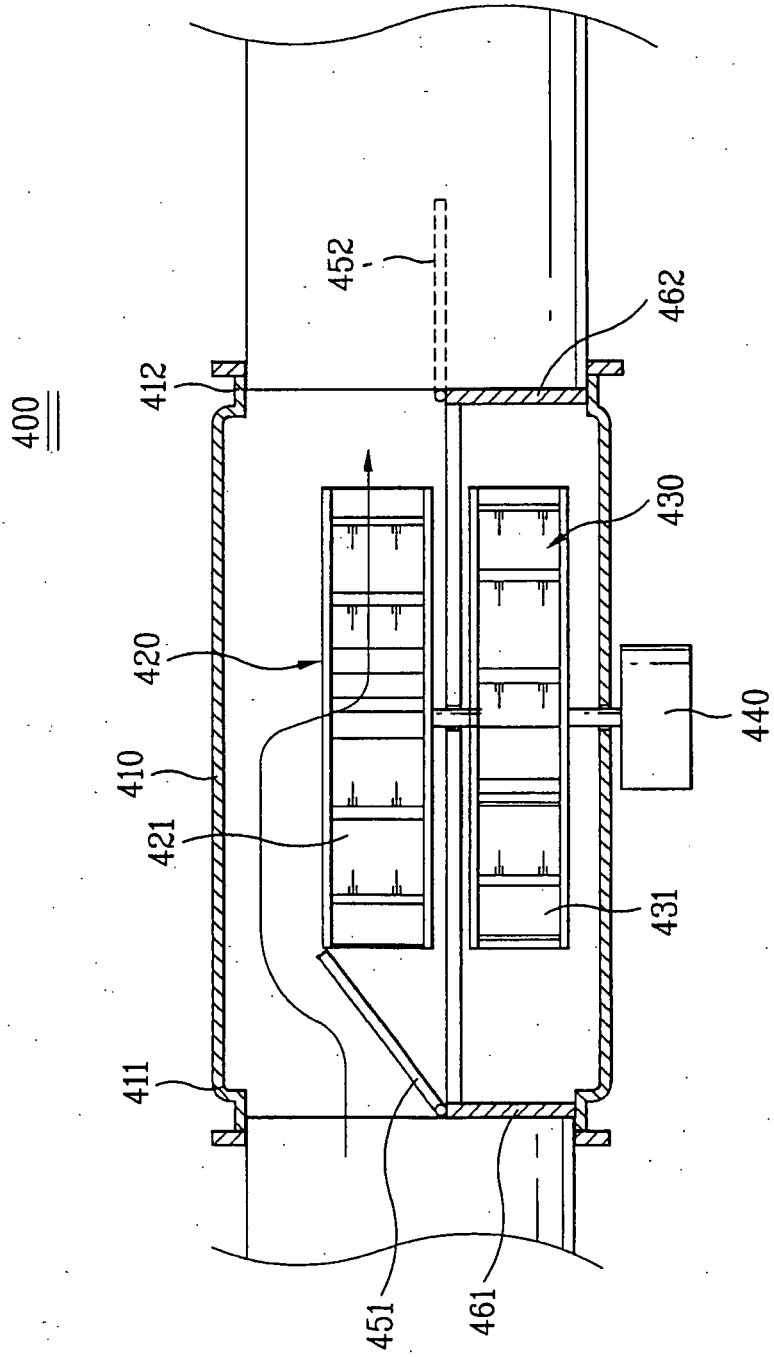
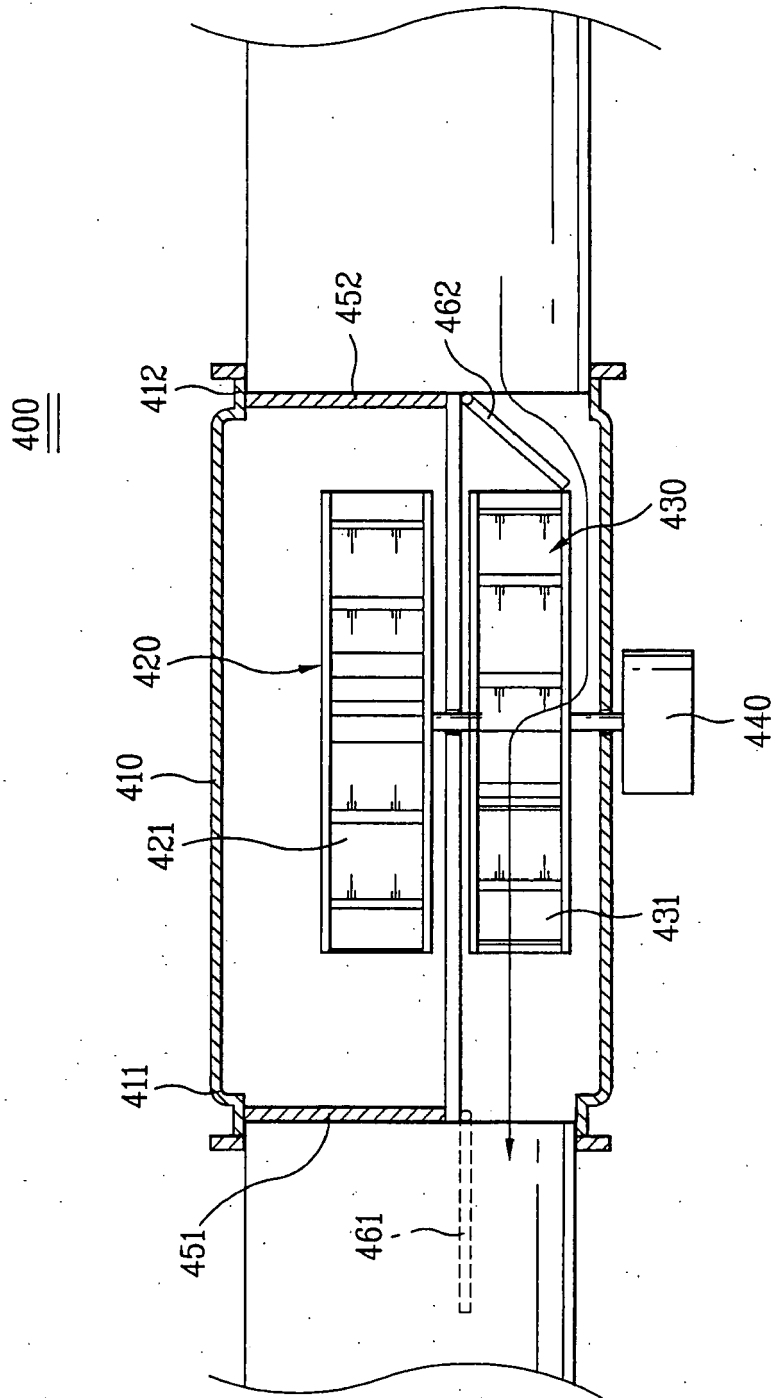

FIG. 8





DOCUMENTS CONSIDERED TO BE RELEVANT			
Category	Citation of document with indication, where appropriate, of relevant passages	Relevant to claim	CLASSIFICATION OF THE APPLICATION (IPC)
X	US 5 236 393 A (MILEWSKI ET AL) 17 August 1993 (1993-08-17)  * the whole document * -----	1,3,4,6, 7,10,13, 14,16, 22,23	INV. F24F7/08 F24F3/044 F24F11/00 F24F11/02
X	US 3 951 205 A (ZILBERMANN ET AL) 20 April 1976 (1976-04-20)  * the whole document * -----	1,3,4,6, 7,10,13, 14,16, 22,23	
X	US 5 976 010 A (REESE ET AL) 2 November 1999 (1999-11-02)  * column 5, line 57 - column 8, line 19 * * column 10, line 54 - column 11, line 28; figures 1,4-6 * -----	1,3,4,6, 7,10,13, 14,16, 22,23	
X	US 5 119 987 A (KOBAYASHI ET AL) 9 June 1992 (1992-06-09) * abstract; figures 1-4,10 * -----	14,16, 21,23	TECHNICAL FIELDS SEARCHED (IPC)  F24F
A	EP 0 819 895 A (LANDIS & STAefa, INC) 21 January 1998 (1998-01-21) * abstract * -----	1,14,22, 23	
A	US 4 942 921 A (HAESSIG ET AL) 24 July 1990 (1990-07-24) * abstract * -----	1,14,22, 23	
The present search report has been drawn up for all claims			
Place of search <b>Munich</b>		Date of completion of the search <b>8 June 2006</b>	Examiner <b>Valenza, D</b>
<p>CATEGORY OF CITED DOCUMENTS</p> <p>X : particularly relevant if taken alone                      Y : particularly relevant if combined with another document of the same category                      A : technological background                      O : non-written disclosure                      P : intermediate document</p> <p>T : theory or principle underlying the invention                      E : earlier patent document, but published on, or after the filing date                      D : document cited in the application                      L : document cited for other reasons                      .....                      &amp; : member of the same patent family, corresponding document</p>			

2  
EPO FORM 1503 03.02 (P04/C01)

**CLAIMS INCURRING FEES**

The present European patent application comprised at the time of filing more than ten claims.

- Only part of the claims have been paid within the prescribed time limit. The present European search report has been drawn up for the first ten claims and for those claims for which claims fees have been paid, namely claim(s):
- No claims fees have been paid within the prescribed time limit. The present European search report has been drawn up for the first ten claims.

**LACK OF UNITY OF INVENTION**

The Search Division considers that the present European patent application does not comply with the requirements of unity of invention and relates to several inventions or groups of inventions, namely:

see sheet B

- All further search fees have been paid within the fixed time limit. The present European search report has been drawn up for all claims.
- As all searchable claims could be searched without effort justifying an additional fee, the Search Division did not invite payment of any additional fee.
- Only part of the further search fees have been paid within the fixed time limit. The present European search report has been drawn up for those parts of the European patent application which relate to the inventions in respect of which search fees have been paid, namely claims:
- None of the further search fees have been paid within the fixed time limit. The present European search report has been drawn up for those parts of the European patent application which relate to the invention first mentioned in the claims, namely claims:



The Search Division considers that the present European patent application does not comply with the requirements of unity of invention and relates to several inventions or groups of inventions, namely:

1. claims: 1-13,22

Ventilation system

---

2. claims: 14-21,23

Pressure intensifying apparatus

---

ANNEX TO THE EUROPEAN SEARCH REPORT  
ON EUROPEAN PATENT APPLICATION NO.

EP 05 01 0026

This annex lists the patent family members relating to the patent documents cited in the above-mentioned European search report. The members are as contained in the European Patent Office EDP file on  
The European Patent Office is in no way liable for these particulars which are merely given for the purpose of information.

08-06-2006

Patent document cited in search report		Publication date	Patent family member(s)	Publication date
US 5236393	A	17-08-1993	NONE	
US 3951205	A	20-04-1976	NONE	
US 5976010	A	02-11-1999	NONE	
US 5119987	A	09-06-1992	GB 2242515 A	02-10-1991
			JP 2714220 B2	16-02-1998
			JP 3286942 A	17-12-1991
			KR 9506160 B1	09-06-1995
EP 0819895	A	21-01-1998	AU 717196 B2	23-03-2000
			AU 1507797 A	29-01-1998
			CA 2198053 A1	18-01-1998
			CN 1174965 A	04-03-1998
			JP 10063341 A	06-03-1998
			NZ 314273 A	27-07-1997
			SG 50807 A1	20-07-1998
			US 5705734 A	06-01-1998
US 4942921	A	24-07-1990	AT 109881 T	15-08-1994
			AU 608697 B2	11-04-1991
			AU 3183689 A	25-08-1989
			DE 68917391 D1	15-09-1994
			EP 0357728 A1	14-03-1990
			WO 8907226 A1	10-08-1989

EPO FORM P0459

For more details about this annex : see Official Journal of the European Patent Office, No. 12/82