



(12) **EUROPEAN PATENT APPLICATION**

(43) Date of publication: **30.08.2006 Bulletin 2006/35** (51) Int Cl.: **A41D 13/12 (2006.01)**

(21) Application number: **06011593.8**

(22) Date of filing: **21.01.2002**

(84) Designated Contracting States:
**AT BE CH CY DE DK ES FI FR GB GR IE IT LI LU
MC NL PT SE TR**

(30) Priority: **19.01.2001 JP 2001011892**

(62) Document number(s) of the earlier application(s) in
accordance with Art. 76 EPC:
02250412.0 / 1 224 876

(71) Applicant: **UNI-CHARM CORPORATION
Shikokuchuo-shi,
Ehime 799-0111 (JP)**

(72) Inventors:
• **Fujikawa, Michiyo
c/o Technical Center
Mitoyo-gun
Kagawa-ken 769-1602 (JP)**

• **Saito, Akiko
c/o Technical Center
Mitoyo-gun
Kagawa-ken 769-1602 (JP)**
• **Hanajiri, Takeshi
c/o Technical Center
Mitoyo-gun
Kagawa-ken 769-1602 (JP)**

(74) Representative: **Eke, Philippa Dianne
Saunders & Dolleymore,
9 Rickmansworth Road
Watford,
Hertfordshire WD18 0JU (GB)**

Remarks:

This application was filed on 06 - 06 - 2006 as a
divisional application to the application mentioned
under INID code 62.

(54) **Disposable surgical gown**

(57) A disposable surgical gown includes a main body including a front body 4 and a back body 5A, 5B; sleeves 3A, 3B extending from both sides of upper ends of the main body; and a pair of auxiliary member 20A, 20B which are provided at inner upper ends of the back body. The auxiliary members are usable to spread the gown. The main body comprises a plurality of assembled sheets having air permeability and liquid non-permeability. The assembled sheets are bonded to each other along a continuous bonding line extending along edges of the sheets.

FIG. 4

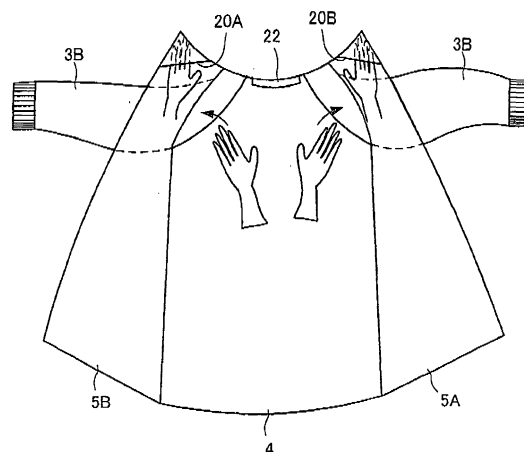

Description

CROSS REFERENCE TO RELATED APPLICATION

5 [0001] This application claims the priority of Application No. 2001-011892, filed January 19, 2001 in Japan, the subject matter of which is incorporated herein by reference.

TECHNICAL FIELD OF THE INVENTION

10 [0002] The present invention relates to a protective gown that is worn by a doctor and a nurse when performing surgical operation, and more particularly, to a gown having an improved barrier or sealing property.

BACKGROUND OF THE INVENTION

15 [0003] Conventionally, a disposable surgical gown includes a main body and sleeves, which are sewed to each other by a sewing machine using threads.

[0004] Japanese Laying Open Publication Kokai No. H04-50304 discloses to employ ultrasonic thermal fusion bonding as a means for bonding a main body to sleeves and to thermal fusion bond them at the same time so as to cover the bonding portion with a different member. Airtightness is improved by covering the bonding portion with the different member.

20 [0005] However, it is difficult for conventional methods to sufficiently prevent infection of disease between patients and wearers (doctors and nurses) of the gown. Further, the method disclosed in Japanese Laying-Open Publication Kokai No. H04-50304 makes a manufacturing process complex and is also disadvantageous in cost because it uses the extra member.

25 OBJECTS OF THE INVENTION

[0006] Accordingly, it is an object of the present invention, which was made in view of the above circumstances, to provide a disposable surgical gown capable of contributing to the improvement of a blocking effect for blocking an infection route between patients and wearers of the gown by preventing the exudation of blood and the like during surgical operation regardless of that the gown is arranged simply.

30 [0007] Additional objects, advantages and novel features of the present invention will be set forth in part in the description that follows, and in part will become apparent to those skilled in the art upon examination of the following or may be learned by practice of the invention. The objects and advantages of the invention may be realized and attained by means of the instrumentalities and combinations particularly pointed out in the appended claims.

35 SUMMARY OF THE INVENTION

[0008] According to a first aspect of the present invention, a disposable surgical gown, includes a main body including a front body and a back body; and sleeves extending from both sides of upper ends of the main body. The main body comprises a plurality of assembly sheets having air permeability and liquid non permeability. The assembly sheets are bonded to each other along a continuous bonding line extending along edges of the sheets.

[0009] According to the above-described invention, the continuously formed bonding line can prevent the exudation of substances such as blood from the bonding portion of the sheets. As a result, it is possible to improve the effect of preventing infection between a patient and a wearer (doctor or nurse) of the gown.

45 [0010] It is preferable that a plurality of discontinuous bonding portions be formed in the vicinity of the continuous bonding line (both of them are disposed together). With this device, when the sheets constituting the gown are bonded to each other by, for example, an ultrasonic sewing machine, and the like, a pressure can be dispersed in the direction perpendicular to the flow direction of the sheets, and the breakage of the gown, which would be caused by the concentration of the pressure to a local area of the continuous bonding line, can be prevented.

[0011] According to a second aspect of the present invention, a disposable surgical gown includes a main body including a front body and a back body; sleeves extending from both sides of upper ends of the main body; and an auxiliary member, which is provided at an inner upper end of the back body. The auxiliary member is folded by an assistant when the gown is worn by a wearer.

50 [0012] Preferably, the auxiliary member comprises two parts which are arranged at upper corners of the back body. The two parts of the auxiliary member may be shaped to be triangle pockets.

[0013] According to a third aspect of the present invention, a disposable surgical gown includes a main body including a front body and a back body; sleeves extending from both sides of upper ends of the main body; and an water-absorbent

sheet provided around a neck portion of the front body for absorbing sweat of a wearer.

[0014] Preferably, the water absorbent sheet is shaped and arranged so as not to extend outwardly from an upper edge of the front body.

5 BRIEF DESCRIPTION OF THE DRAWINGS

[0015]

10 FIG. 1 is a front view showing the structure of a surgical gown of according to an embodiment of the present invention, in which the gown is spread right and left and viewed from a front body side.
 FIG. 2 is a rear view showing the surgical gown according to the embodiment, in which the gown is worn and viewed from a back body side;
 FIG. 3 is a plan view showing the surgical gown according to the embodiment in a disassembled state before component parts thereof are bonded to each other;
 15 FIG. 4 is a view explaining a manner when the surgical gown according to the present invention is spread and worn from a back side;
 FIG. 5 is a perspective view showing the structure of an absorbent sheet used in the surgical gown according to the embodiment and a state in which the absorbent sheet is used;
 FIG. 6 is a plan view showing an example of the bonding pattern of the surgical gown according to the embodiment.
 20 FIG. 7 is a plan view showing an example of the bonding pattern of the surgical gown according to the embodiment.
 FIG. 8 is a plan view showing an example of the bonding pattern of the surgical gown according to the embodiment.
 FIG. 9 is a plan view showing an example of the bonding pattern of the surgical gown according to the embodiment.
 FIG. 10 is a plan view showing an example of the bonding pattern of the surgical gown according to the embodiment.
 FIG. 11 is a plan view showing an example of the bonding pattern of the surgical gown according to the embodiment.
 25 FIG. 12 is a plan view showing an example of the bonding pattern of the surgical gown according to the embodiment.
 FIG. 13 is a plan view showing an example of the bonding pattern of the surgical gown according to the embodiment.
 FIG. 14 is a plan view showing an example of the bonding pattern of the surgical gown according to the embodiment;
 FIG. 15 is a plan view showing an example of the bonding pattern of the surgical gown according to the embodiment.

30 DETAILED DISCLOSURE OF THE INVENTION

[0016] In the following detailed description of the preferred embodiments, reference is made to the accompanying drawings which forma part hereof, and in which is shown by way of illustration specific preferred embodiments in which the inventions may be practiced. These embodiments are described in sufficient detail to enable those skilled in the art
 35 to practice the invention, and it is to be understood that other embodiments may be utilized and that logical, mechanical and electrical changes may be made without departing from the spirit and scope of the present inventions. The following detailed description is, therefore, not to be taken in a limiting sense, and scope of the present inventions is defined only by the appended claims.

[0017] An embodiment of the present invention will be described below. A gown according to this embodiment is used
 40 as a disposable gown that is worn by doctors, nurses, and the like in surgical operation. The gown of the present invention can be also applied to medical fields other than operation where it is necessary to block the infection route of disease causing germs and to fields other than the medical field where high liquid tightness, dust controllability, and the like are required.

[0018] FIG. 1 is a front view showing the arrangement of the surgical gown of the embodiment when it is spread and
 45 viewed from a front body side. FIG. 2 is a rear view showing the gown when it is worn and viewed from a back body side. Further, FIG. 3 is a plan view showing the gown in a disassembled state before the members thereof are bonded to each other (assembled).

[0019] The surgical gown according to the embodiment includes a front body 4, a left back body 5A, a right back body 5B, and both sleeves 3A and 3B. The front body 4 includes a single sheet. A back body includes two sheets 5A and 5B
 50 such that when the gown is worn, free side edges (5aL and 5aR) are put together on the back of a wearer. Waist belts 8A, 8B, 9A, and 9B are attached to the side edges of the back bodies 5A and 5B. Further, a hook portion 12 and a loop portion 13 that constitute a mechanical fastener are attached to neckline portions of the back bodies 5B and 5A, respectively. Elastic sleeve ribs 7A and 7B are provided at cuffs of both the sleeves 3A and 3B.

[0020] In the surgical gown according to the embodiment, fusion bonding by means of an ultrasonic sewing machine, or the like or bonding by means of an adhesive is carried out to bond the lower sleeve portions 3dL and 3dR of both the
 55 sleeves 3A and 3B to each other; to bond the sleeve attachment portion 3aL of the left sleeve 3A to the arm hole 4f of the front body 4; to bond the sleeve attachment portion 3aR of the right sleeve 3B to the arm hole 4f of the front body 4; to bond the sleeve attachment portion 3bL of the left sleeve 3A to the arm hole 5fL of the back body 5A; to bond the

sleeve attachment portion 3bR of the right sleeve 3B to the arm hole 5fR of the back body 5B; to bond the left side edge 4a of the front body 4 to the fixed side edge 5bL of the back body 5A; and to bond the right side edge 4b of the front body 4 to the fixed side edge 5bR of the back body 5B, respectively.

5 [0021] Thermal sealing, sonic sealing performed by ultrasonic waves, and the like are exemplified as a means for performing fusion bonding. Further, bonding performed by means of a hot-melt adhesive, and the like are exemplified as the bonding by means of the adhesive. Note that a material of a sheet and a method of bonding the sheet will be described below.

10 [0022] Triangular auxiliary pockets 20A and 20B are disposed to the upper back end corners of the free side edges 5aL and 5aR of the back bodies 5A and 5B, respectively. FIG. 4 is a view showing a method of spreading the gown according to the embodiment and wearing it from a back side. The auxiliary pockets 20A and 20B are used by an assistant such as a nurse, or the like who assists a doctor, or the like when he or she wears the gown. At that time, the assistant spreads the gown right and left with hands inserted into the auxiliary pockets 20A and 20B. With this operation, the doctor, or the like can wear the gown without being in contact with external unwanted bacteria. Note that members having a shape other than the pocket shape such as belt-like members may be employed in place of the auxiliary pockets 20A and 20B. In short, various types of members can be applied as long as they permit the assistant to spread the gown in the inside thereof and to hold it.

15 [0023] It is preferable that the auxiliary pockets 20A and 20B be located as near to the upper end corners as possible because the main body of the gown is composed a flexible and soft material. With this arrangement, it can be prevented that the upper end corners of the gown are bent downward when it is spread with hands inserted into the auxiliary pockets 20A and 20B and that the smooth wearing of the gown is disturbed thereby.

20 [0024] An absorbent sheet 22 for absorbing sweat of the wearer is attached to the inside of the neckline portion 4e of the front body 4. As shown by a dotted line in FIG. 5, when the absorbent sheet 22 is used, the portion thereof upper than a central portion is bonded to the inside surface of the neckline portion 4e of the front body 4. When the absorbent sheet 22 is attached, it is important that the upper end portion thereof does not project above the neckline portion 4e. In other words, the absorbent sheet 22 does not extend outwardly from the top edge of the front body 4. When the upper end portion of the absorbent sheet 22 projects above the neckline portion 4e, it is exposed to the outside of the gown, which is not preferable from a sanitary point of view. Further, it is important to secure the portion of the absorbent sheet 22 located upper than the central portion. This is because that when a structure, in which the portion of the absorbent sheet lower than the central portion is secured, is employed, the upper side portion of the absorption sheet 22 hangs down, and thereby the wearing property (fitting property) of the gown to the wearer is impaired.

25 [0025] Non-woven fabric such as spun lace, and thermal bond can be used as the material of the absorbent sheet 22. The non-woven fabric that constitutes the absorbent sheet 22 includes, for example, 30 to 90% of thermosetting resin fibers and 10 to 70% of absorbent fibers. The thermosetting fibers are selected from olefin fibers such as polyethylene fibers, polypropylene fibers, etc., polyester fibers, and polyamide fibers. The absorbent fibers can be selected from pulp, cotton, rayon, acetate, etc.

30 [0026] Next, the material and the bonding method of the sheet that constitutes the surgical gown according to the embodiment will be described in detail. Figs. 6 to 15 show the bonding patterns of the bonding portion of the surgical gown of the embodiment. When a sonic sewing machine is used, a fusion pattern (welding pattern) corresponding to any of these patterns is formed on the surface of a roll. Note that, the portions filled in with slanted lines in the respective figures show bonding regions, and further arrows show the direction in which the sheet flows.

35 [0027] The bonding pattern shown in FIG. 6 includes a linear portion (straight portion) 30 and a plurality of dot patterns 32 arranged on the both sides of the linear portion 30. The bonding line is formed while the sheets are flowing along an assembly line. For example, the width W of the linear portion 30 in the direction perpendicular to the flow direction of the sheets is set to 1 mm, the diameter of the respective dot patterns 32 is set to 1 mm the center distance between outer dot patterns 32 is set to about 6 mm, and the center line (pitch) of dot patterns 32 that are juxtaposed in the flow direction of the sheets is set to about 2.5 mm.

40 [0028] While the bonding pattern shown in FIG. 7 is similar to the bonding pattern shown in FIG. 6, the intervals between dot patterns 32 are somewhat narrowed. For example, the width W of a linear portion 30 in the direction perpendicular to the flow direction of the sheets is set to 1 mm, the diameter of respective dot patterns 32 is set to 1 mm, the center distance between outer dot patterns 32 is set to about 4.6 mm, and the center distance between dot patterns 32 that are juxtaposed in the flow direction of the sheets is set to about 2.0 mm.

45 [0029] The bonding pattern shown in FIG. 8 includes a continuous wave-shaped portion 34 and two lanes of rectangular patterns 36 arranged inwardly of the sheet. For example, the maximum width (amplitude) W1 of the wave-shaped portion 34 in the direction perpendicular to the flow direction of the sheets is set to of 2 mm, the lateral width (length in the flow direction of the sheets) of the respective rectangular patterns 36 is set to 3 mm, and the interval between the respective rectangular patterns 36 that are juxtaposed in the flow direction of the sheets is set to about 0.8 mm.

50 [0030] The bonding pattern shown in FIG. 9 includes a lattice-shaped pattern 38 that intersects at an angle of 45°. For example, the total width W of the lattice-shaped pattern 38 in the direction perpendicular to the flow direction of the

sheets is set to 5 mm, the width of the respective stripes that constitutes a lattice is set to 1 mm, and the pitch of parallel stripes is set to about 2.5 mm.

[0031] The bonding pattern shown in FIG. 10 includes a single linear portion 30 and a plurality of rectangular (square) patterns 40 arranged on both the sides of the linear portion 30. For example, the width W of the linear portion 30 in the direction perpendicular to the flow direction of the sheets is set to 1 mm, the length of one side of the respective rectangular patterns 40 is set to 1 mm, the center distance between outer rectangular patterns 40 is set to about 4.6 mm, and the center distance between rectangular patterns 40 that are juxtaposed in the flow direction of the sheets is set to about 2.0 mm.

[0032] While the bonding pattern shown in FIG. 11 is similar to the bonding pattern shown in FIG. 10, the intervals between rectangular patterns 40 are somewhat widened. For example, the width W of a linear portion 30 in the direction perpendicular to the flow direction of the sheets is set to 1 mm, the length of one side of respective rectangular patterns 40 is set to 1 mm, the center distance between outer rectangular patterns 40 is set to about 6 mm, and the center distance between rectangular patterns 40 that are juxtaposed in the direction perpendicular to the flow direction of the sheets is set to about 2.5 mm.

[0033] The bonding pattern shown in FIG. 12 includes a thick linear bonding line 42 and a multiplicity of dot-shaped non-bonding portions 44 defined in the bonding line 42. For example, the width W of the bonding line 42 in the direction perpendicular to the flow direction of the sheets is set to 7 mm, the center distance (pitch) between the respective dot patterns 44 is set to 1.2 mm.

[0034] The bonding pattern shown in FIG. 13 includes a combination of ellipse portions 46 that are long in a width direction and small circle portions 48, and the ellipse portions 46 and the small circle portions 48 are alternately combined in the flow direction of the sheets. Each of the ellipse portions 46 and the small circle portions 48 is formed in a donut shape having a non-bonding portion therein. For example, the width W in the direction perpendicular to the flow direction of the sheets is set to 6 mm, the pitch of the ellipse portions 46 is set to 3.9 mm, and the inside diameter and the pitch of the circular portions 48 are set to 1. mm and 3.9 mm.

[0035] The bonding pattern shown in FIG. 14 includes a spiral pattern 50. For example, the width W of the pattern 50 in the direction perpendicular to the flow direction of the sheets is set to 6 mm, the pitch of spirals is set to 2.5 mm, and the width of non-bonding region in the flow direction of the sheets is set to 1.5 mm.

[0036] The bonding pattern shown in FIG. 15 includes a lattice-shaped pattern 52 that intersects at 45°. For example, the width W of the pattern 52 in the direction perpendicular to the flow direction of the sheets is set to 7 mm, the width of the stripes that constitute a lattice is set to 0.7 mm, and the pitch of parallel stripes is set to about 1.7 mm.

[0037] As shown in FIGS. 6 to 15, a plurality of discontinuous bonding portions are arranged adjacent a continuous bonding line (both of them are formed at the same time), so that a pressure to disperse in the direction perpendicular to the flow direction of the sheets is dispersed. Accordingly, when sheets constituting the gown are bonded to each other by, for example, an ultrasonic sewing machine, and the like, the breakage of the gown, which would be caused by the concentration of the pressure to a local area of the continuous bonding line, can be prevented.

[0038] When the sheets that constitute the gown are sealed by fusion bonding, the width of the bonding line is preferably set to within the range of 0.1 to 15 mm and more preferably to within the range 0.5 to 10 mm. When the width of the bonding line is 0.1 mm or less, a line pressure in the direction perpendicular to the flow direction of the sheets increases, and thereby there is a possibility that a fusion bonded portion is broken. In contrast, when the width of the bonding line is 15 mm or more, the wearer has uncomfortable feeling and workability is lowered because the rigidity of the bonding portion itself is higher than that of the non-bonding portion.

[0039] As described above, the linear shape, the wave shape, the zigzag shape, the lattice shape, and the like can be employed as the pattern of the seal line, and it is also possible to combine these shapes with the dot-shaped (discontinuous) pattern to regulate the line pressure in the direction perpendicular to the flow direction of the sheets.

[0040] When the bonding line is formed by the adhesive, it is preferable to use the hot-melt adhesive. Exemplified as patterns, which are formed when the hot-melt adhesive is applied, are an all-over-applied pattern and a stripe pattern formed by a coater die, a net-shaped pattern formed by a gravure coater, a linear pattern formed by bead coating, and a spiral pattern, a wave-shaped pattern, a zigzag pattern, and the like regulated by air (not shown).

[0041] When the bonding portion of the sheets is formed by the adhesive, it is preferable to set the width of the bonding portion to 1 to 15 mm. When the width of the bonding portion is 1 mm or less, bonding strength for bonding the sheets is lowered, and there is a possibility that the sheets are exfoliated while they are used. It is preferable that the bonding strength is 980 mN/25 mm or more in terms of exfoliation strength,

[0042] A spunbonded fabric formed of thermoplastic fibers, non-woven fabric such as spun lace, needle punch, melt-blown, thermal bond, chemical bond, a laminate sheet including non-woven fabric laminated to a thermoplastic resin sheet, and a three-layer structure including non-woven fabric, a thermoplastic resin sheet, and non-woven fabric can be used as the sheets used for the front and back bodies 4, 5A, and 5B and for both the sleeves 3A and 3B. Exemplified as a means for laminating the non-woven fabric to the thermoplastic resin sheet are direct laminating for extruding the thermoplastic resin sheet and fusing it, wet laminating performed using an adhesive, dry laminating, laminating performed

using a hot-melt adhesive, heat embossing performed using heat or ultrasonic waves, and the like.

[0043] Polyolefine fibers, polyester fibers, polyamide fibers, and thick and thin type or side by side type composite fibers including polyethylene fibers and polypropylene fibers or polyester fibers can be used as the fibers constituting the non-woven fabric.

[0044] It is possible to form predetermined apertures to the non-woven fabric used as the sheets for constituting the surgical gown of the present invention in order to improve the air permeability thereof. Further, it is also possible to form concave and convex portions to the sheets by embossing them in order to improve the cushioning property of the sheets or to provide the sheets with an expanding/contracting property. A plastic sheet including polyethylene, polypropylene, polyester, polyurethane, or the like can be used as the thermoplastic resin sheet. Further, a composite non-woven fabric (SMS, SMMS non-woven fabric) including melt-blown non-woven fabric, which has high water resistance and both the surfaces of which are sandwiched between the sheet surfaces of spunbonded non-woven fabric having high strength and abounding with flexibility also can be used.

[0045] It is preferable that the entire strength of these sheets be at least 2500 mN/25 mm and that the vapor permeability thereof be at least 800g/m² · 24 hours. When the strength of the sheets is less than 2500 mN/25 mm, there is a possibility that the sheets are broken when the wearer moves. Further, when the vapor permeability is less than 800 g/m² · 24 hours, the wearer gets stuffy and has uncomfortable feeling.

[0046] When the surgical gown according to the embodiment arranged as described above is to be worn, an assistant such as a nurse, or the like inserts hands into the auxiliary pockets 20A and 20B and spreads the gown both right and left. Next, a doctor, who wears operating gloves, wears the gown by inserting hands through the cuffs without coming into contact with the outside surface of the gown. Sweat coming from the vicinity of the face of the doctor during a surgical operation is absorbed by the absorbent sheet 22 located at his or her neck.

[0047] While the embodiment of the present invention has been described above, the present invention is by no means limited thereto, and it is needless to say that the design of the surgical gown may be appropriately varied within the range of the spirit disclosed in the appended claims. In particular, the sheets constituting the surgical gown need not be always different in the front body and the back bodies, and further any type of sheet cutting (patterning) method may be employed.

[0048] As described above in detail, since the bonding portions of the sheets constituting the surgical gown are continuously bonded in the present invention, the bonding portions are neither exfoliated nor broken even if the wearer moves intensely. Further, the exudation of substances such as blood from the bonding portions of the sheets can be prevented because no clearance is formed in the bonding portions due to the continuously formed bonding line. As a result, the effect of preventing infection between a patient and a wearer (doctor or nurse) of the surgical gown can be improved.

[0049] The following clauses define features of the invention:

Clauses

Clause 1. A disposable surgical gown, comprising:

a main body including a front body and a back body; and sleeves extending from both sides of upper ends of the main body, wherein

the main body comprises a plurality of assembly sheets having air permeability and liquid non-permeability, the assembly sheets being bonded to each other along a continuous bonding line extending along edges of the sheets.

Clause 2. A disposable surgical gown according to Clause 1, wherein

the bonding line is any one of a fusion-bonded seal line and a seal line using an adhesive.

Clause 3. A disposable surgical gown according to Clause 1, wherein

the bonding line is formed to be any one selected from a linear or straight bonding line, a wave-shaped bonding line, a zigzag bonding line, a lattice-shaped bonding line, a spiral bonding line, or a combination thereof.

Clause 4. A disposable surgical gown according to Clause 1, wherein

a plurality of discontinuous bonding portions are arranged adjacent the continuous bonding line.

EP 1 695 638 A1

Clause 5. A disposable surgical gown according to Clause 1, wherein

5 the bonding line is formed while the sheets are flowing along an assembly line; and
the width of the bonding line in a direction perpendicular to the flowing direction of the sheets is set to 0.1
mm to 15 mm.

Clause 6. A disposable surgical gown according to Clause 1, further comprising:

10 an auxiliary member, which is provided at an inner upper end of the back body, wherein
the auxiliary member is folded by an assistant when the gown is worn by a wearer.

Clause 7. A disposable surgical gown according to Clause 6, wherein

15 the auxiliary member comprises two parts which are arranged at upper corners of the back body.

Clause 8. A disposable surgical gown according to Clause 7, wherein

20 the two parts of the auxiliary member are shaped to be triangle pockets.

Clause 9. A disposable surgical gown according to Clause 1, further comprising:

25 a water-absorbent sheet provided around a neck portion of the front body for absorbing sweat of a wearer.

Clause 10. A disposable surgical gown according to Clause 9, wherein

30 the water-absorbent sheet is shaped and arranged so as not to extend outwardly from an upper edge of
the front body.

Clause 11. A disposable surgical gown according to Clause 6, further comprising:

35 a water-absorbent sheet provided around a neck portion of the front body for absorbing sweat of a wearer.

Clause 12. A disposable surgical gown, comprising:

40 a main body including a front body and a a back body;
sleeves extending from both sides of upper ends of the main body; and
an auxiliary member, which is provided at an inner upper end of the back body, wherein
the auxiliary member is folded by an assistant when the gown is worn by a wearer.

Clause 13. A disposable surgical gown according to Clause 12, wherein

45 the auxiliary member comprises two parts which are arranged at upper corners of the back body.

Clause 14. A disposable surgical gown according to Clause 13, wherein

50 the two parts of the auxiliary member are shaped to be triangle pockets.

Clause 15. A disposable surgical gown according to Clause 12, further comprising:

55 a water-absorbent sheet provided around a neck portion of the front body for absorbing sweat of a wearer.

Clause 16. A disposable surgical gown, comprising:

a main body including a front body and a back body;
sleeves extending from both sides of upper ends of the main body; and
a water-absorbent sheet provided around a neck portion of the front body for absorbing sweat of a wearer.

Clause 17. A disposable surgical gown according to Clause 16, wherein

the water-absorbent sheet is shaped and arranged so as not to extend outwardly from an upper edge of the front body.

5 **Claims**

1. A disposable surgical gown, comprising;

10 a main body including a front body (4) and a back body (5A, 5B);
sleeves (3A, 3B) extending from both sides of upper ends of the main body; and
an auxiliary member (20A, 20B), which is provided at an inner upper end of the back body (5A, 5B);
wherein the auxiliary member (20A, 20B) is folded by an assistant when the gown is worn by a wearer.

15 2. A disposable surgical gown according to Claim 1, wherein
the auxiliary member (20A, 20B) comprises two parts which are arranged at upper corners of the back body (5A, 5B).

3. A disposable surgical gown according to Claim 2, wherein
the two parts of the auxiliary member (20A, 20B) are shaped to be triangle pockets.

20 4. A disposable surgical gown as claimed in any preceding claim, wherein
the main body comprises a plurality of assembly sheets having air permeability and liquid non-permeability, the
assembly sheets being bonded to each other along a continuous bonding line (30) extending along edges of the
sheets.

25 5. A disposable surgical gown according to Claim 4, wherein
the bonding line (30) is any one of a fusion-bonded seal line and a seal line using an adhesive.

30 6. A disposable surgical gown according to Claim 4 or Claim 5, wherein
the bonding line (30) is formed to be any one selected from a linear or straight bonding line, a wave-shaped bonding
line (34), a zigzag bonding line, a lattice-shaped bonding line (38, 52), a spiral bonding line (50), or a combination
thereof.

35 7. A disposable surgical gown according to any one of Claims 4 to 6, wherein
a plurality of discontinuous bonding portions (32, 40) are arranged adjacent the continuous bonding line.

8. A disposable surgical gown according to any one of Claims 4 to 7, wherein
the width of the bonding line (30) is set to 0.1 mm to 15 mm.

40 9. A disposable surgical gown according to any preceding claim, further comprising:

a water-absorbent sheet (22) provided around a neck portion (4e) of the front body (4) for absorbing sweat of
a wearer.

45 10. A disposable surgical gown according to Claim 9, wherein
the water-absorbent sheet (22) does not extend outwardly from an upper edge of the front body (4).

50

55

FIG. 1

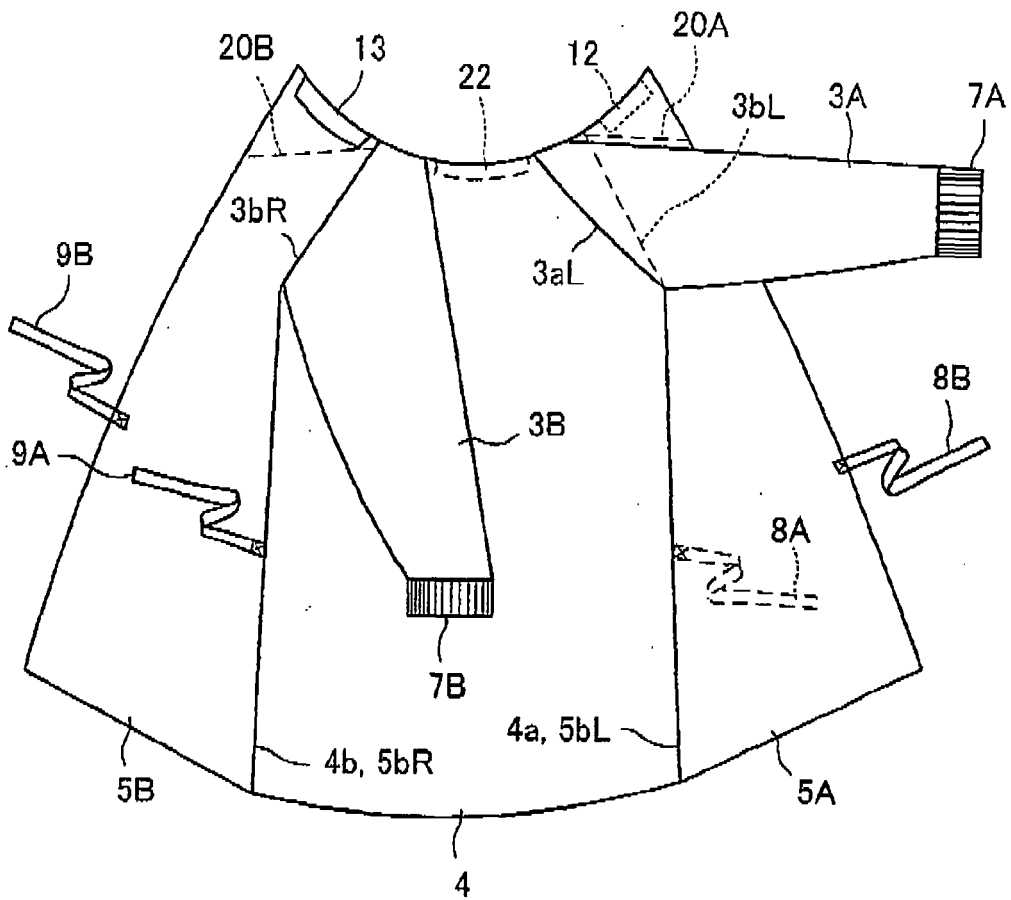

FIG. 2

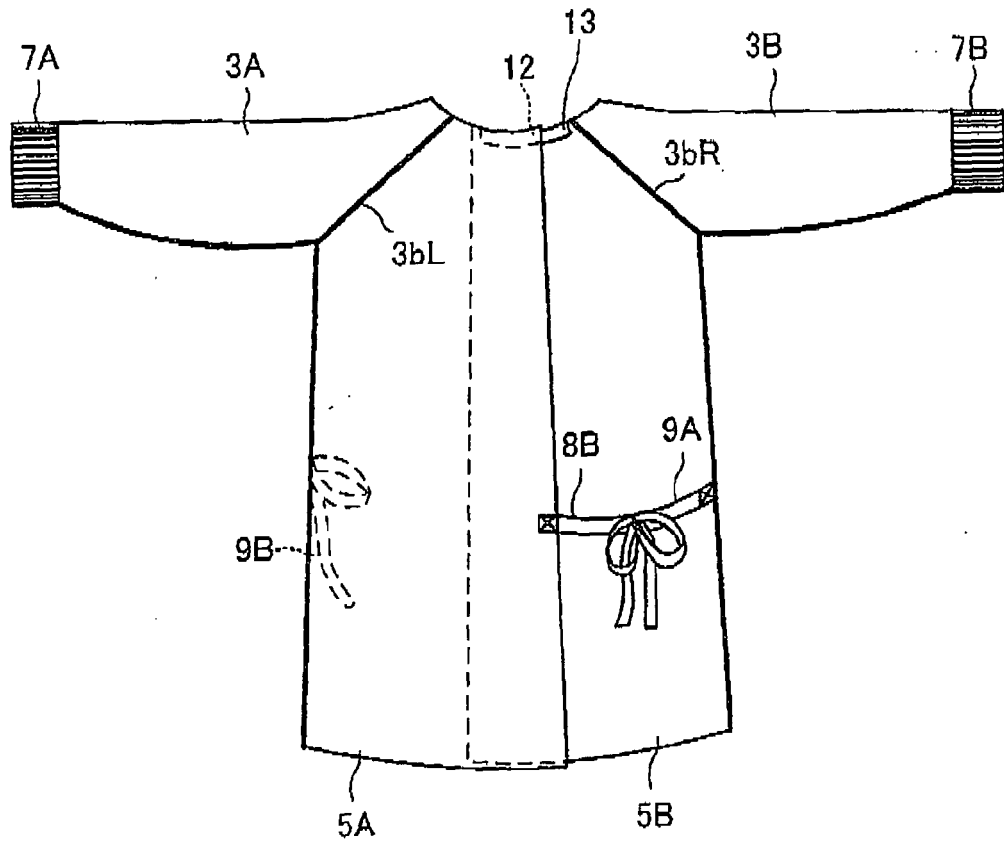

FIG. 3

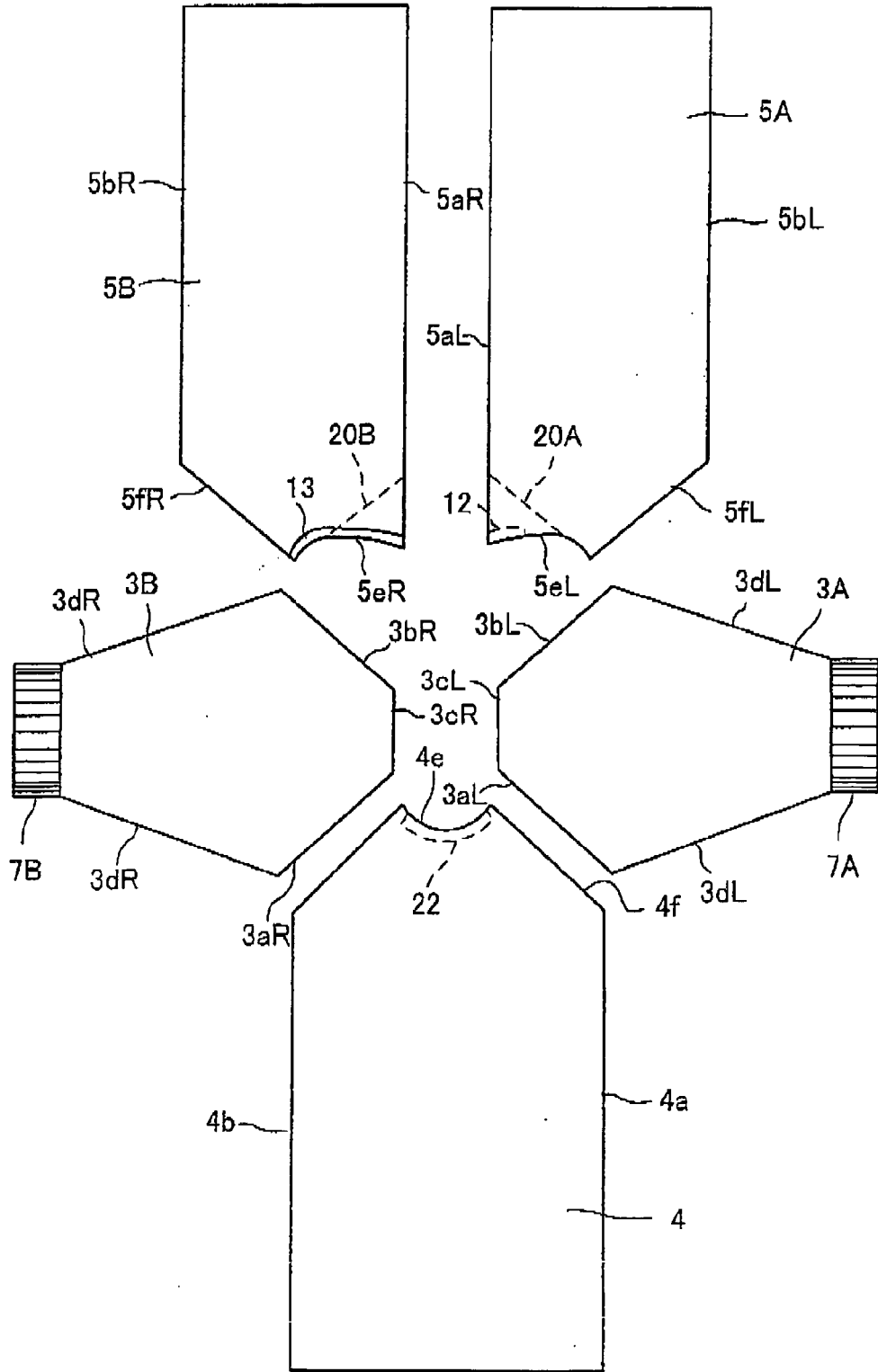

FIG. 4

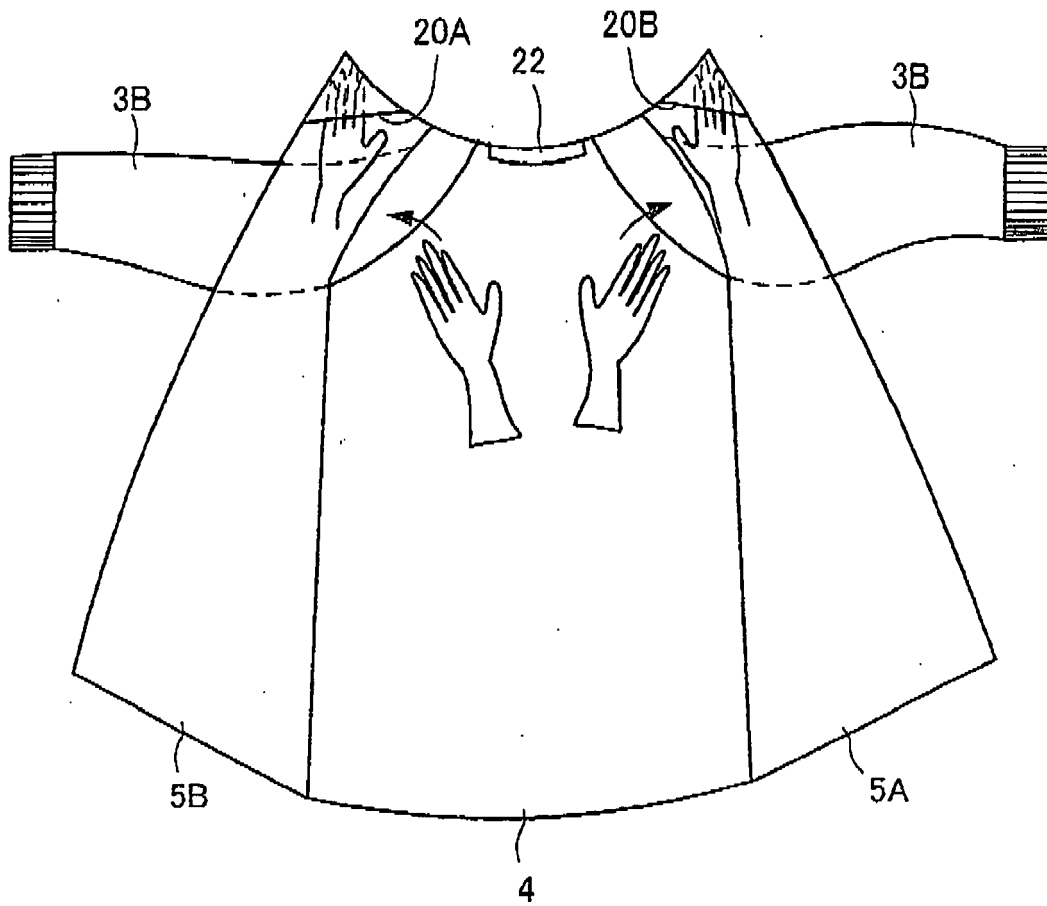

FIG. 5

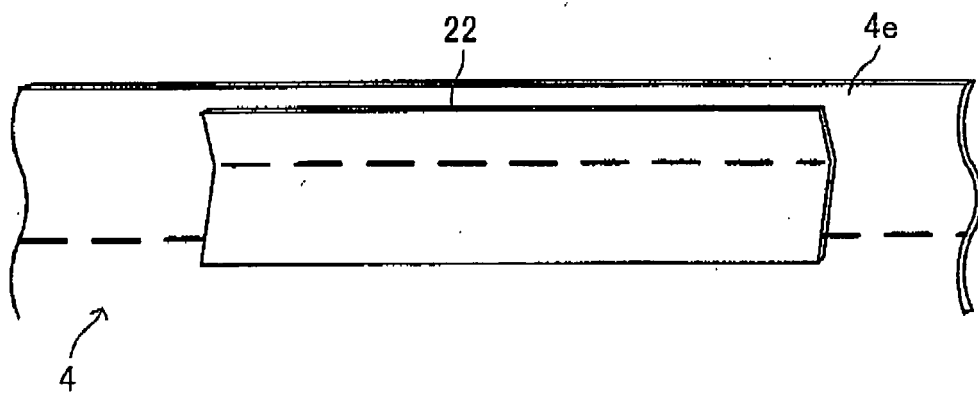

FIG. 6

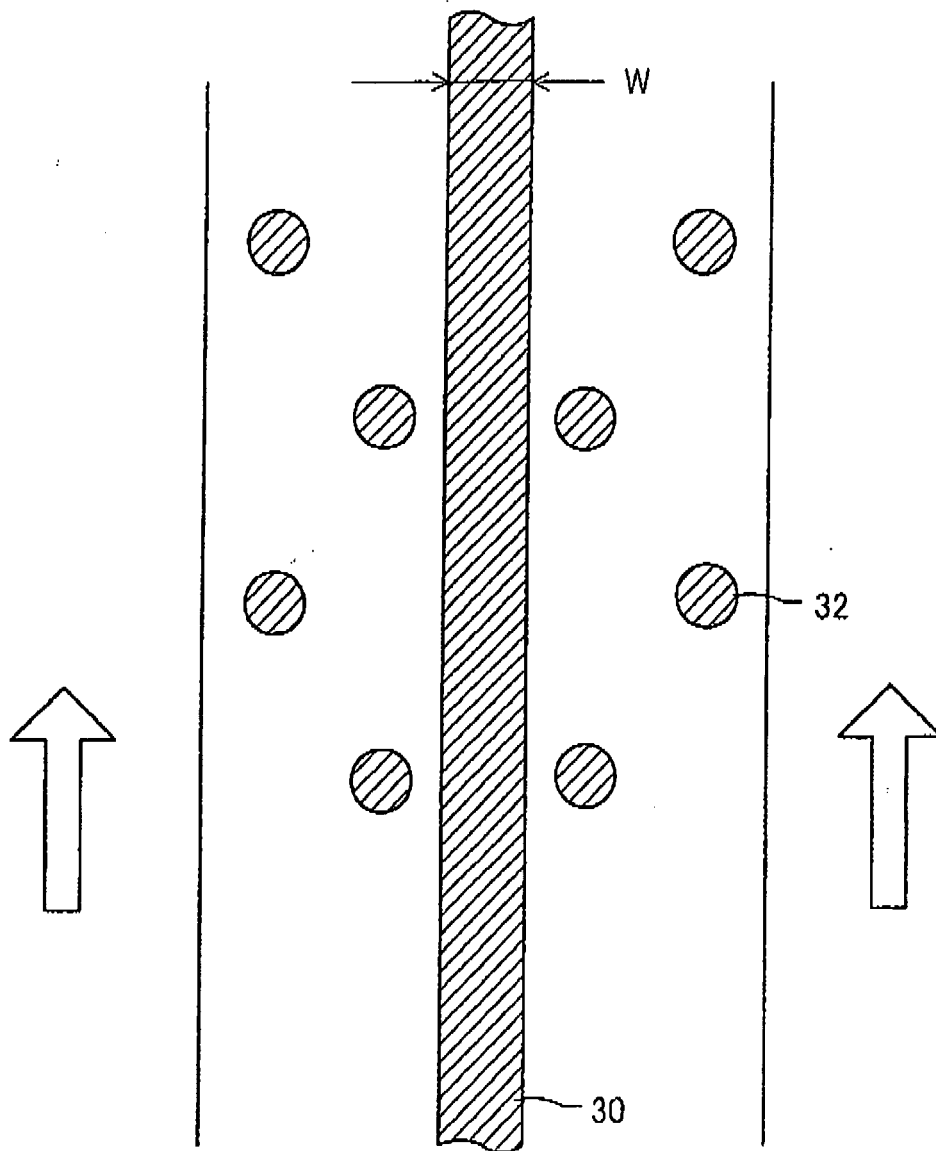

FIG. 7

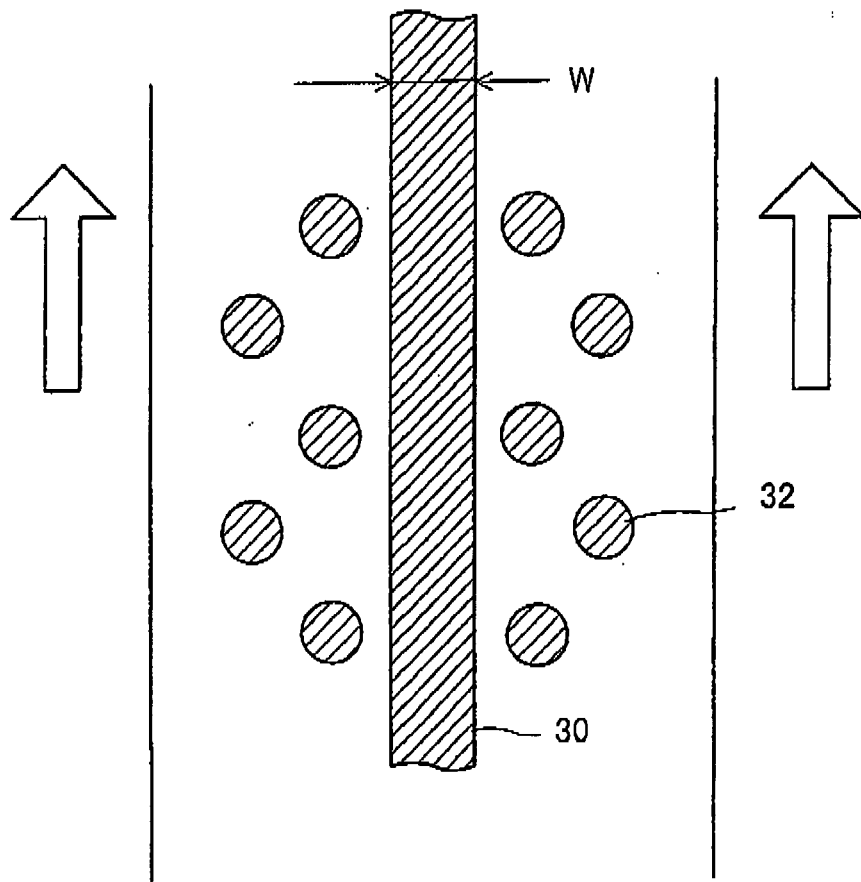

FIG. 8

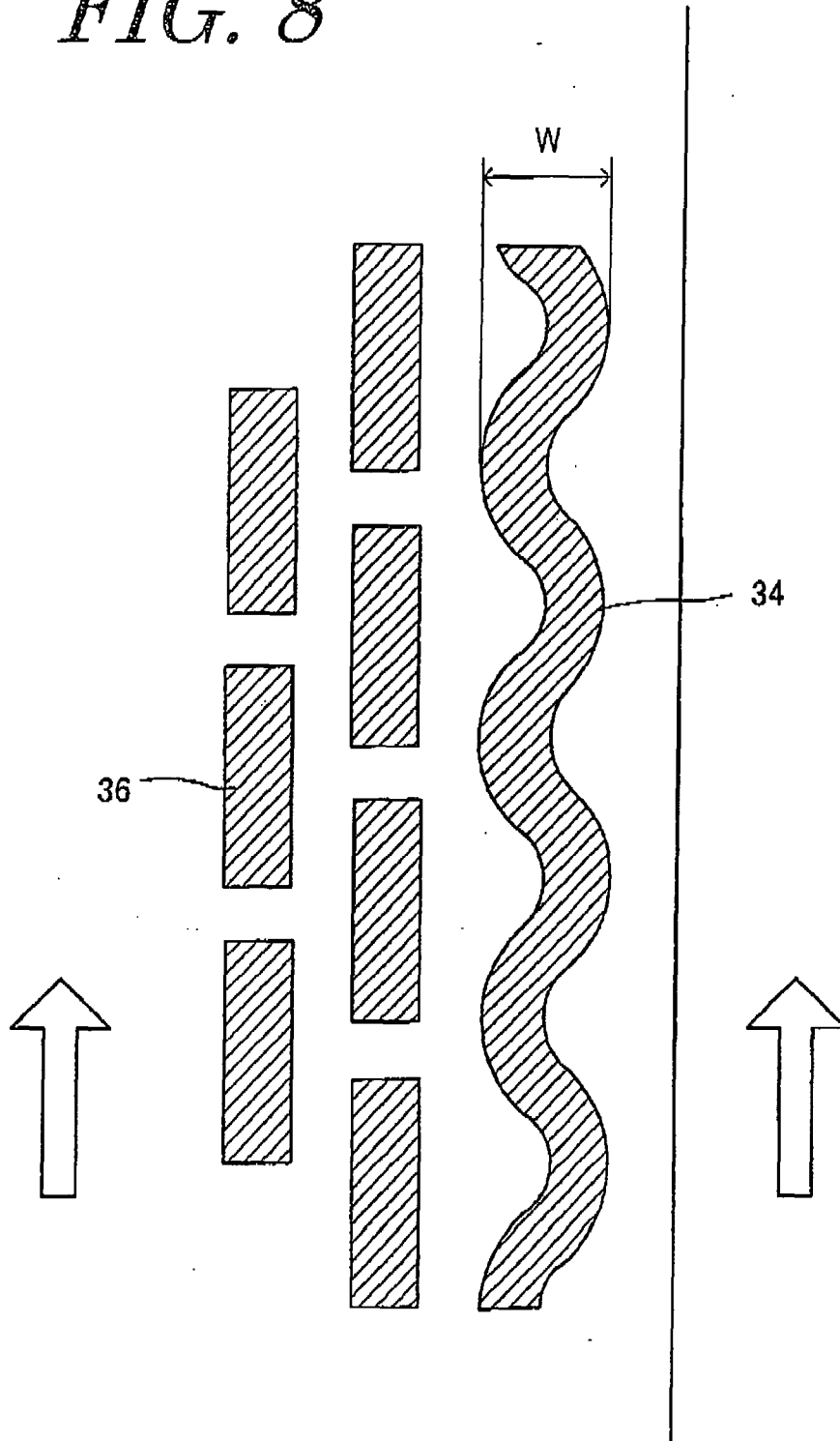

FIG. 9

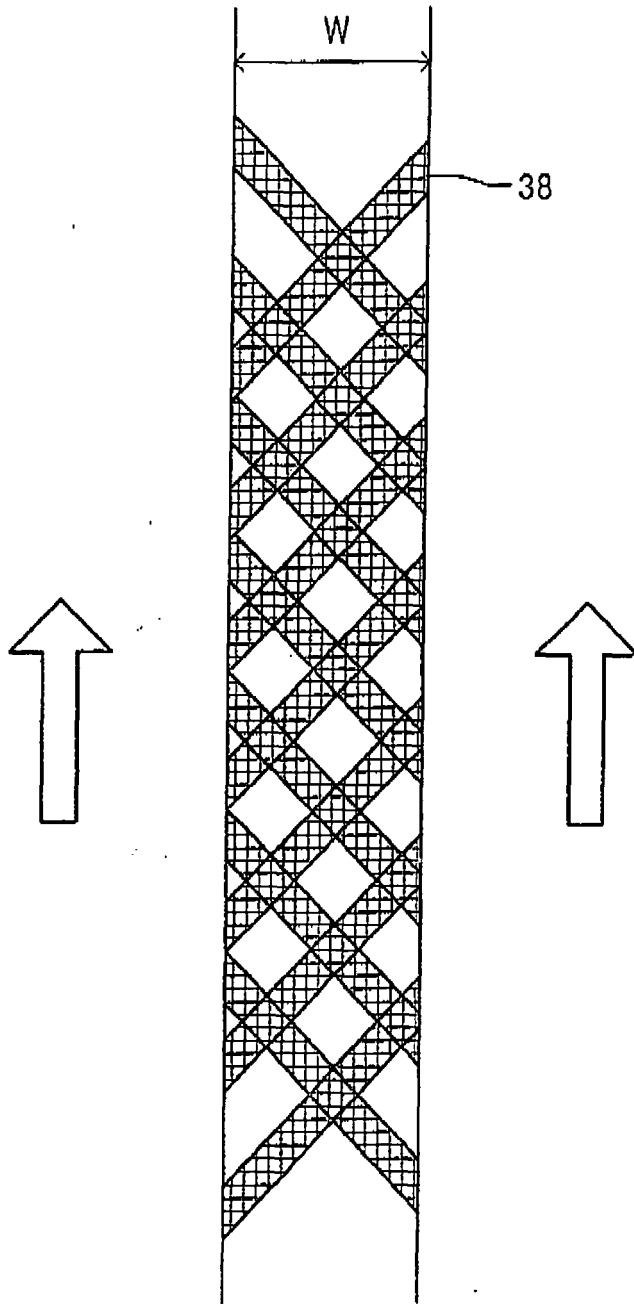

FIG. 10

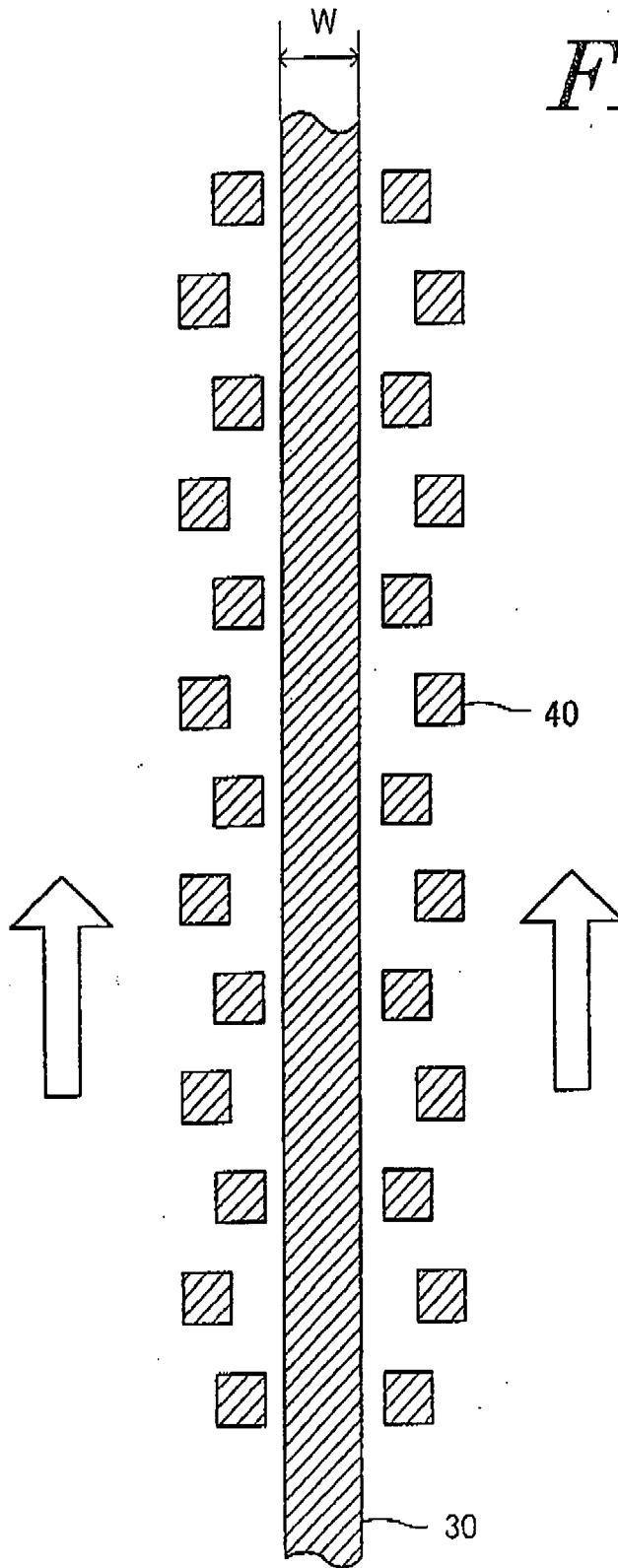

FIG. 11

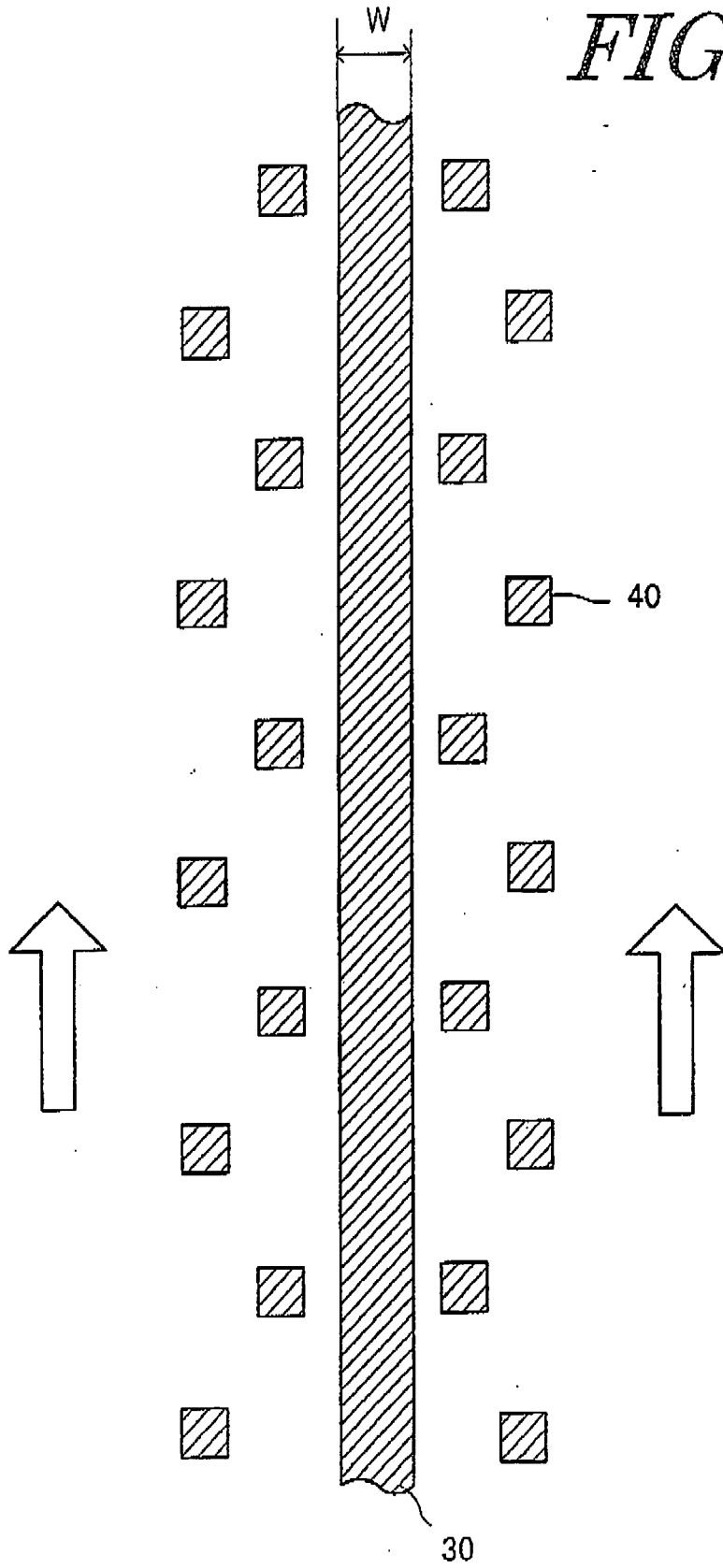

FIG. 12

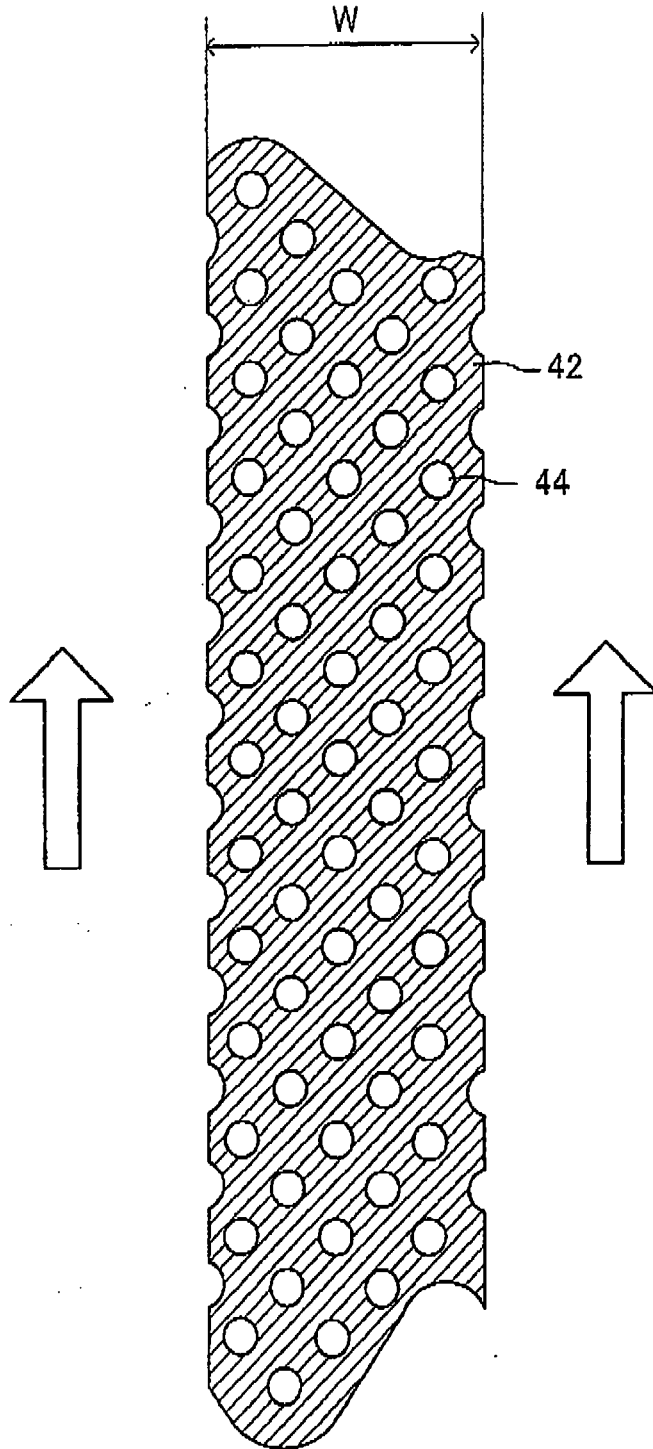

FIG. 13

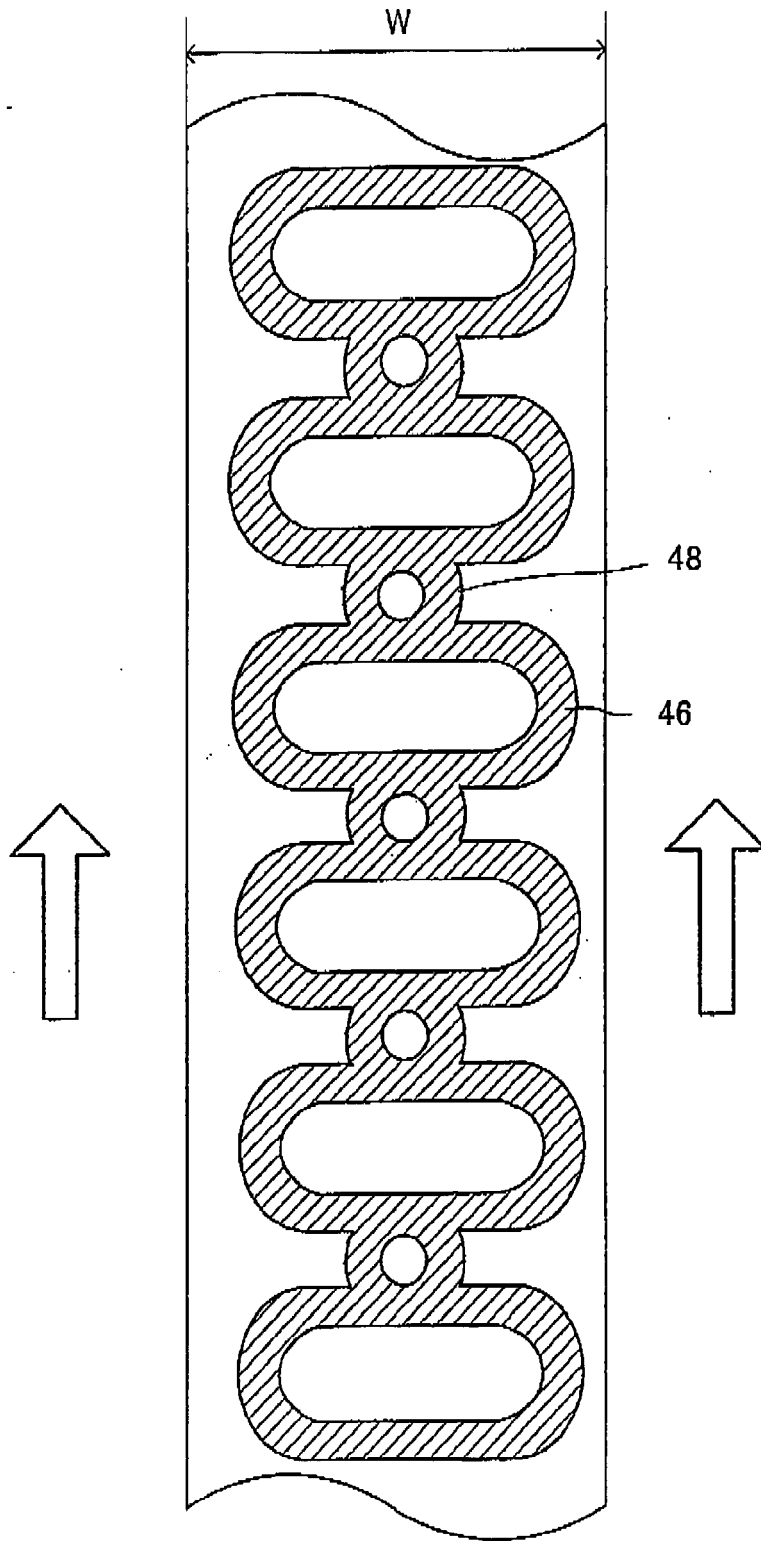

FIG. 14

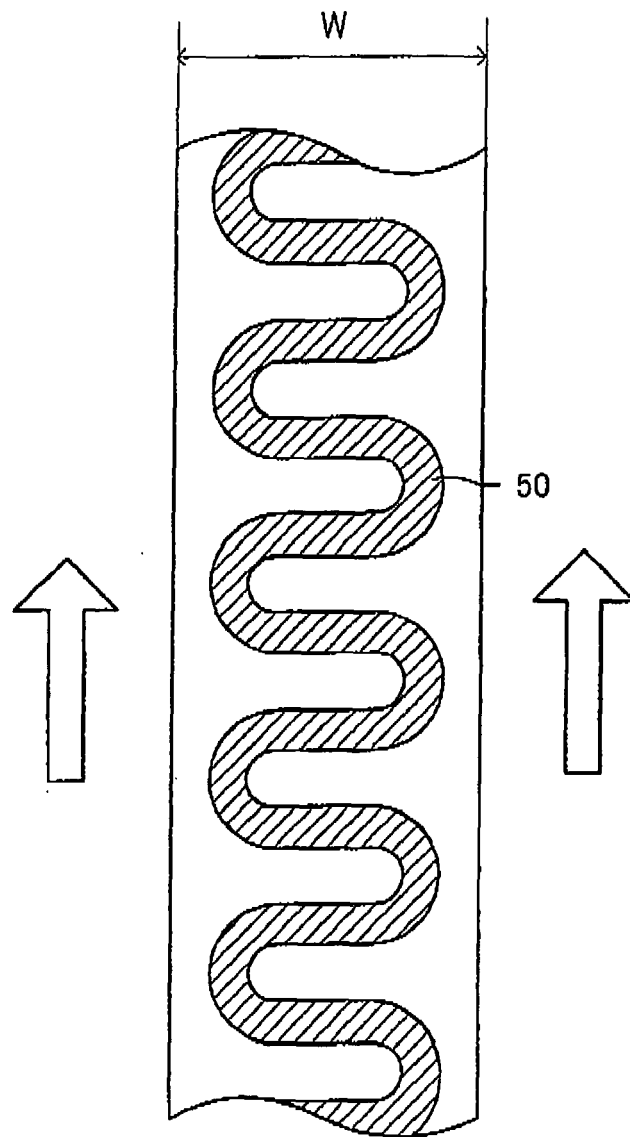
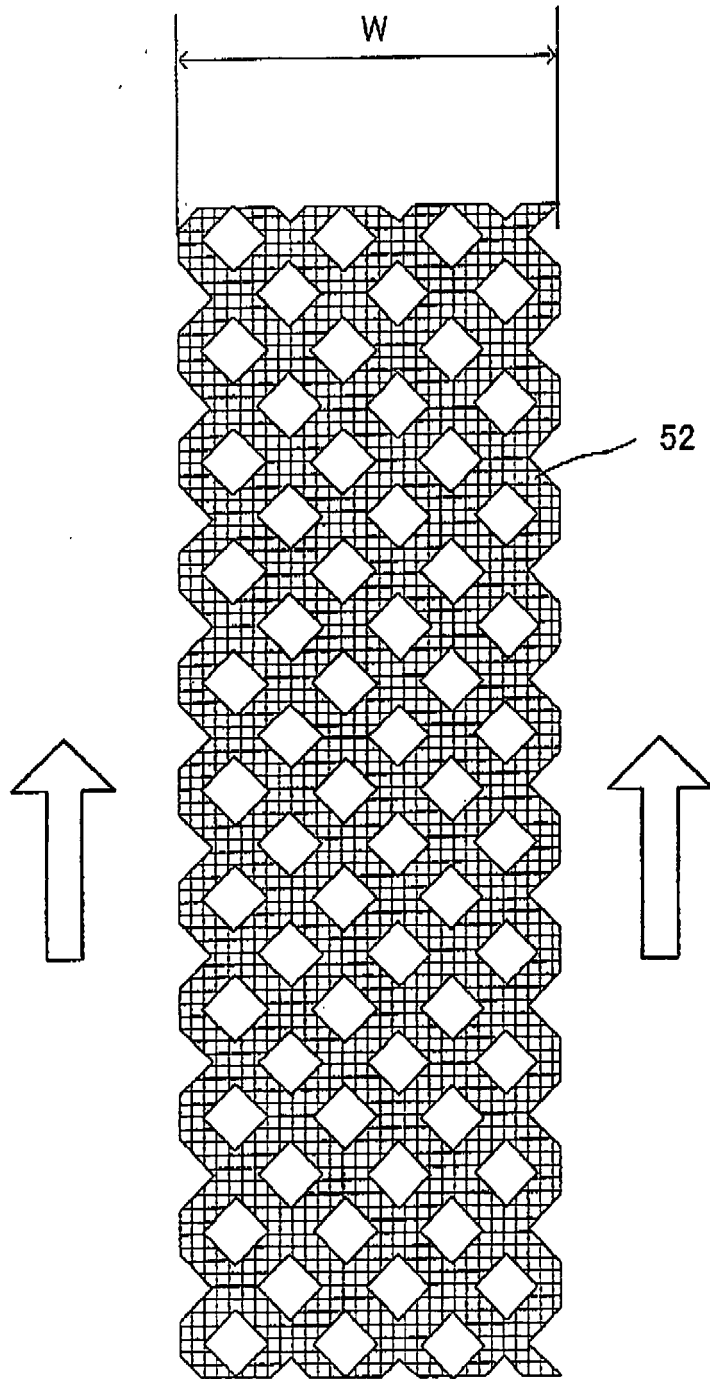

FIG. 15





DOCUMENTS CONSIDERED TO BE RELEVANT			
Category	Citation of document with indication, where appropriate, of relevant passages	Relevant to claim	CLASSIFICATION OF THE APPLICATION (IPC)
A	US 3 359 569 A (ROTANZ ROBERT J ET AL) 26 December 1967 (1967-12-26) * column 2, line 8 - line 16 * * column 3, lines 3-10,28-41; figures 1,5 * * column 4, lines 5-17,45-57 * -----	1-3	INV. A41D13/12
A	US 5 862 525 A (TANKERSLEY ET AL) 26 January 1999 (1999-01-26) * column 5, line 44 - line 50; figures 1,2 * -----	1-3	
A	US 3 570 012 A (TERRY L. WINTERS) 16 March 1971 (1971-03-16) * column 4, line 29 - line 41; figures 4-7 * -----	1-3	
T	MAY-PLUMLEE T.; PITTMAN A.: "Surgical Gown Requirements Capture: A Design Analysis Case Study" JOURNAL OF TEXTILES AND APPAREL, TECHNOLOGY AND MANAGEMENT, [Online] vol. 2, no. 2, April 2002 (2002-04), pages 1-10, XP002390375 Retrieved from the Internet: URL:www.tx.ncsu.edu/jtatm/volume2issue2/articles/mayplumlee/plumlee_full.pdf> [retrieved on 2005-01-14] * page 2, paragraph 3 * * page 4, left-hand column, last paragraph - page 5, left-hand column, paragraph 2 * * page 5, right-hand column, paragraph 1 * ----- -/--	1-8	TECHNICAL FIELDS SEARCHED (IPC) A41D
The present search report has been drawn up for all claims			
Place of search Munich		Date of completion of the search 14 July 2006	Examiner Uhlig, R
CATEGORY OF CITED DOCUMENTS X : particularly relevant if taken alone Y : particularly relevant if combined with another document of the same category A : technological background O : non-written disclosure P : intermediate document		T : theory or principle underlying the invention E : earlier patent document, but published on, or after the filing date D : document cited in the application L : document cited for other reasons & : member of the same patent family, corresponding document	

6
EPO FORM 1503 03.02 (P04C01)



DOCUMENTS CONSIDERED TO BE RELEVANT			
Category	Citation of document with indication, where appropriate, of relevant passages	Relevant to claim	CLASSIFICATION OF THE APPLICATION (IPC)
A	US 5 919 539 A (BISBIS BENYOUSSEF Y ET AL) 6 July 1999 (1999-07-06) * column 1, line 11 - line 20 * * column 3, line 54 * * column 4, line 13 - line 24; figures 3-6 *	4-7	
A	----- EP 1 060 679 A (UNI CHARM COMPANY LTD) 20 December 2000 (2000-12-20) * paragraph [0026] - paragraph [0035]; claims *	5	
A	----- US 5 879 493 A (JOHNSON ET AL) 9 March 1999 (1999-03-09) * column 2, line 50 - line 59; figures 2,9A,9B,10 * * column 11, line 28 - line 59 * * column 16, line 28 - line 37 *	7	
A	----- WO 01/03527 A (SAITO AKIKO ;UNI CHARM CORP (JP); MATSUSHITA MICHIO (JP)) 18 January 2001 (2001-01-18) * figures 2,3 *	9,10	
The present search report has been drawn up for all claims			TECHNICAL FIELDS SEARCHED (IPC)
Place of search		Date of completion of the search	Examiner
Munich		14 July 2006	Uhlig, R
CATEGORY OF CITED DOCUMENTS		T : theory or principle underlying the invention E : earlier patent document, but published on, or after the filing date D : document cited in the application L : document cited for other reasons & : member of the same patent family, corresponding document	
X : particularly relevant if taken alone Y : particularly relevant if combined with another document of the same category A : technological background O : non-written disclosure P : intermediate document			

6
EPO FORM 1503 03.02 (P04C01)

**CLAIMS INCURRING FEES**

The present European patent application comprised at the time of filing more than ten claims.

- Only part of the claims have been paid within the prescribed time limit. The present European search report has been drawn up for the first ten claims and for those claims for which claims fees have been paid, namely claim(s):
- No claims fees have been paid within the prescribed time limit. The present European search report has been drawn up for the first ten claims.

LACK OF UNITY OF INVENTION

The Search Division considers that the present European patent application does not comply with the requirements of unity of invention and relates to several inventions or groups of inventions, namely:

see sheet B

- All further search fees have been paid within the fixed time limit. The present European search report has been drawn up for all claims.
- As all searchable claims could be searched without effort justifying an additional fee, the Search Division did not invite payment of any additional fee.
- Only part of the further search fees have been paid within the fixed time limit. The present European search report has been drawn up for those parts of the European patent application which relate to the inventions in respect of which search fees have been paid, namely claims:
- None of the further search fees have been paid within the fixed time limit. The present European search report has been drawn up for those parts of the European patent application which relate to the invention first mentioned in the claims, namely claims:



The Search Division considers that the present European patent application does not comply with the requirements of unity of invention and relates to several inventions or groups of inventions, namely:

1. claims: 1-10

1.1. claims: 1-3

Surgical gown with donning means

1.2. claims: 4-8

Surgical gown with donning means and sealed seams

1.3. claims: 9,10

Surgical gown with donning means and absorbent sheet around the neck

Please note that all inventions mentioned under item 1, although not necessarily linked by a common inventive concept, could be searched without effort justifying an additional fee.

**ANNEX TO THE EUROPEAN SEARCH REPORT
ON EUROPEAN PATENT APPLICATION NO.**

EP 06 01 1593

This annex lists the patent family members relating to the patent documents cited in the above-mentioned European search report. The members are as contained in the European Patent Office EDP file on
The European Patent Office is in no way liable for these particulars which are merely given for the purpose of information.

14-07-2006

Patent document cited in search report		Publication date	Patent family member(s)	Publication date
US 3359569	A	26-12-1967	GB 1188141 A	15-04-1970
			GB 1188142 A	15-04-1970

US 5862525	A	26-01-1999	AU 6792498 A	30-10-1998
			DE 69832287 D1	15-12-2005
			EP 1007778 A1	14-06-2000
			SK 134599 A3	16-05-2000
			TW 419548 B	21-01-2001
			WO 9845522 A1	15-10-1998
			US 6062444 A	16-05-2000
			ZA 9802995 A	21-10-1998

US 3570012	A	16-03-1971	NONE	

US 5919539	A	06-07-1999	NONE	

EP 1060679	A	20-12-2000	AU 1684000 A	26-06-2000
			BR 9907983 A	07-05-2002
			CA 2320310 A1	15-06-2000
			CN 1290135 A	04-04-2001
			ID 26344 A	14-12-2000
			WO 0033687 A1	15-06-2000
			JP 3662434 B2	22-06-2005
			JP 2000170011 A	20-06-2000

US 5879493	A	09-03-1999	JP 9031834 A	04-02-1997
			US 5682618 A	04-11-1997

WO 0103527	A	18-01-2001	AU 6014200 A	30-01-2001
			JP 2001032107 A	06-02-2001
