



(11) **EP 1 702 133 B1**

(12) **EUROPEAN PATENT SPECIFICATION**

(45) Date of publication and mention of the grant of the patent:
07.11.2007 Bulletin 2007/45

(51) Int Cl.:
E21B 4/04 (2006.01) E21B 4/18 (2006.01)
E21B 43/10 (2006.01)

(21) Application number: **04798682.3**

(86) International application number:
PCT/GB2004/004986

(22) Date of filing: **25.11.2004**

(87) International publication number:
WO 2005/061835 (07.07.2005 Gazette 2005/27)

(54) **METHOD FOR DRILLING AND LINING A WELLBORE**

VERFAHREN ZUM BOHREN UND VERROHREN EINES BOHRLOCHS

PROCEDE DE FORAGE D'UN Puits ET DE MISE EN PLACE D'UN CUVELAGE

(84) Designated Contracting States:
AT BE BG CH CY CZ DE DK EE ES FI FR GB GR HU IE IS IT LI LU MC NL PL PT RO SE SI SK TR

(30) Priority: **22.12.2003 GB 0329712**

(43) Date of publication of application:
20.09.2006 Bulletin 2006/38

(73) Proprietors:
• **BP EXPLORATION OPERATING COMPANY LIMITED**
Sunbury-on-Thames TW16 7BP (GB)
• **XL Technology, Ltd**
Ascot,
Berks SL5 7NT (GB)

(72) Inventors:
• **HEAD, Philip**
Springwoods,
Virginia Water,
Surrey GU25 (GB)
• **LURIE, Paul George**
East Horsley,
Surrey KT24 6AF (GB)

(74) Representative: **Hymers, Ronald Robson**
BP INTERNATIONAL LIMITED
Patents Division
Chertsey Road
Sunbury-on-Thames
Middlesex, TW16 7LN (GB)

(56) References cited:
US-A1- 2001 052 427 US-A1- 2003 034 177

EP 1 702 133 B1

Note: Within nine months from the publication of the mention of the grant of the European patent, any person may give notice to the European Patent Office of opposition to the European patent granted. Notice of opposition shall be filed in a written reasoned statement. It shall not be deemed to have been filed until the opposition fee has been paid. (Art. 99(1) European Patent Convention).

Description

[0001] The present invention relates to drilling a wellbore and to lining the wellbore without having to remove the drilling assembly from the wellbore. More particularly, the invention relates to a system of drilling a wellbore and of completing the well through the expansion of tubulars. More particularly still, the invention relates to the drilling of a wellbore and of lining the wellbore by expansion of one tubular into another to provide a sealed connection therebetween without having to pull the drilling assembly from the wellbore.

[0002] Wellbores are typically formed by drilling and thereafter lining a borehole with steel pipe called casing. The casing provides support to the wellbore and facilitates the isolation of certain sections of the wellbore adjacent hydrocarbon bearing formations. The casing typically extends down the wellbore from the surface of the well and the annulus between the outside of the casing and the borehole wall is filled with cement to permanently set the casing in the wellbore.

[0003] As the wellbore is drilled to a new depth, additional strings of pipe are run into the well to that depth whereby the upper portion of the string of pipe (hereinafter referred to as "liner"), is overlapping the lower portion of the casing. The liner is then fixed or hung in the wellbore, usually by some mechanical slip means well known in the art.

[0004] Emerging technology permits wellbore tubulars to be expanded *in situ*. In addition to simply enlarging a tubular, the technology permits the physical attachment of a smaller tubular to a larger tubular by increasing the outer diameter of a smaller tubular by means of a radial force applied from within the smaller tubular. The expansion can be accomplished by a mandrel or a cone-shaped member urged through the tubular that is to be expanded or by any other known expander tool.

[0005] By utilizing an expander tool, the upper end of a liner can be expanded into the surrounding casing. In this manner, the conventional slip assembly and its related setting tools are eliminated. In one example, the liner is run into the wellbore on a run-in string with the expander tool disposed in the liner and connected thereto by a temporary connection. As the assembly reaches a predetermined depth whereby the top of the liner is adjacent a lower section of the casing, the expander tool is actuated and then, through rotational and/or axial movement of the actuated expander tool within the liner, the liner wall is expanded past its elastic limits and into contact with the wall of the casing. Rotation of the expander tool is performed by rotating the run-in string or by utilizing a mud motor in the run-in string to transfer hydraulic power to rotational movement.

[0006] Published US Patent Application US 2003/0034177 discloses a method of providing in excess of 60 kilowatts of electrical power to the electrical motor of a subterranean electric drilling machine through a substantially neutrally buoyant composite umbilical contain-

ing electrical conductors to reduce the frictional drag on the neutrally buoyant umbilical. The method facilitates the extended reach drilling of boreholes up to 20 miles. The umbilical is preferably divided into several lengths. A method is disclosed for drilling a new borehole from an existing borehole lined with casing using the subterranean electric drilling machine. The subterranean electric drilling machine may carry with it into the borehole being drilled a length of expandable casing attached to a casing hanger. Within the casing hanger is a casing hanger setting tool to expand the casing hanger so that it can make positive hydraulic and mechanical contact to the interior of the previously installed casing. Once the expandable casing is locked in place by the casing hanger setting tool, the subterranean electric drilling machine releases from the casing and is recovered from the well, leaving the casing hanger and expandable casing in its unexpanded state in the well. Thereafter, another tool, called a subterranean liner expansion tool is conveyed into the wellbore to expand the expandable casing, optionally with prior cementing of the casing. The drilling and casing operation in the preferred embodiment is a two-trip process. The application also describes a tractor conveyance means which can be powered by electrical energy delivered via the umbilical. The tractor means can be used to move equipment within the well.

[0007] Published US Patent Application US 2001/0052427 relates to a steering assembly with electric power from the surface and communication to and from the surface which can change the bend angle and the direction of a drill bit while drilling a borehole. The bottom hole assembly is connected to a workstring, such as coiled tubing, composite coiled tubing or drill pipe and may also be used with wireline.

[0008] The present invention relates to a method of drilling a second wellbore section from a first wellbore section that is lined with a tubular liner using a remotely controlled electrically powered drilling assembly that is suspended from a cable and of periodically interrupting the drilling operation to extend the tubular liner into the second wellbore section without having to pull the assembly from the wellbore.

[0009] Thus, according to the present invention there is provided a method of drilling a second wellbore section from a first wellbore section that is lined with a tubular liner and of extending the tubular liner into the second wellbore section, the method comprising:

- (a) drilling the second wellbore section from the first wellbore section using a remotely controlled electrically powered drilling assembly that is suspended from a cable that extends from the surface wherein the cable comprises an upper and a lower length of cable connected by a cable connection means and the drilling assembly comprises an expansion means, a traction means, and an electrically actuated drill bit and wherein electricity is transmitted to the assembly via at least one electrical wire and/or

segmented electrical conductor that extends from the surface to the assembly;

(b) introducing an expandable liner pipe into the wellbore by disconnecting the cable connection means at the surface to separate the upper and lower lengths of cable, arranging the expandable liner pipe concentrically about the upper or lower length of cable, reconnecting the cable connection means to rejoin the upper and lower lengths of cable and running the expandable liner pipe into the wellbore supported on a traction means that is moveable along the cable (hereinafter "cable traction means"); and

(c) actuating the expansion means of the assembly to expand the upper portion of the expandable liner pipe into the lower portion of the tubular liner to form a sealed connection therebetween and to expand the lower portion of the expandable liner pipe to extend the tubular liner; and

(d) optionally repeated steps (a) to (c).

[0010] Although the method of the present invention is described in relation to a substantially vertical wellbore, it will be apparent to the person skilled in the art that the method of the present invention may also be used to drill and to line a side-track wellbore or a lateral wellbore that is drilled from an existing wellbore. By "side-track wellbore" is meant a branch of an existing wellbore where the existing wellbore no longer produces hydrocarbon fluid. Thus, the existing wellbore is sealed below the selected location from which the side-track wellbore is to be drilled, for example, with cement. By "lateral wellbore" is meant a branch of an existing wellbore where the existing wellbore continues to produce hydrocarbon fluid. The side-track or lateral well may be drilled at any angle from the existing wellbore. Even in such wells, the wellbore is generally drilled to increasing depth and the terms "upper" and "lower" or "above" and "below" should be understood in this context. Similarly, a person skilled in the art would understand that although it would be preferable for the expandable liner pipe and cable to have the same axis, the term "concentric" is not used in its strict mathematical sense and a degree of eccentricity can be tolerated or even desired.

[0011] An advantage of the method of the present invention is that the cable traction means may be used to deliver expandable liner pipe to the second wellbore section without having to pull the assembly from the wellbore. A further advantage of the present invention is that the rock pore pressure is controlled by sealing the wellbore wall with the expandable liner pipe thereby allowing a simple single density mud to be employed during the drilling operation. Suitably, the pressure of the simple single density mud may be increased as the second wellbore section is drilled to greater depth by pressurising the mud at the surface. Yet a further advantage of the process of the present invention is the potential reduction in the non-production drilling time (NPT) by reducing or at least mitigating wellbore stability problems (including loss circu-

lation and stuck pipe) associated with prior art drilling and lining operations.

[0012] Where the second wellbore section is a continuation of a first wellbore section, which is the initial section of the wellbore, the tubular liner may be a conductor, i.e. a short string of large diameter pipe that is used to keep the upper part of a wellbore open or a casing, i.e. a string of pipe, in particular, steel pipe, that is run from the surface into the wellbore. Generally, a conductor is drilled or pushed into a wellbore to a depth of 100 to 1000 feet (30.5 to 305 m). It is envisaged that a conductor may be drilled or pushed to the bottom of the first wellbore section. Alternatively, a conductor may be pushed into the upper part of the first wellbore section and a casing may then be run from the surface to the bottom of the first wellbore section. Drilling of the second wellbore section is then commenced using the drilling assembly suspended from the cable. Drilling of the second wellbore section is then interrupted and the cable connection means is disconnected to disconnect the upper and lower lengths of cable. A first expandable liner pipe is then arranged concentrically about the upper or lower length of cable, preferably the latter, the upper and lower lengths of cable are reconnected and the first expandable liner pipe is run into the wellbore along the cable supported on the cable traction means. The upper portion of this first expandable liner pipe is then expanded into the tubular liner of the first wellbore section to form a sealed connection therebetween. In particular, the upper portion of the first expandable liner pipe may be expanded into either the lower portion of a conductor or into the lower portion of a casing that has been run into the first wellbore section through a conductor. The lower portion of the first expandable liner pipe is also expanded to extend the tubular liner into the second section of wellbore. Drilling of the second wellbore section is recommenced and is then interrupted to run a further expandable liner pipe into the wellbore along the cable supported on the cable traction means in a similar manner to the first expandable liner pipe. The upper portion of this further expandable liner pipe is expanded into the lower portion of the tubular liner to form a sealed connection therebetween while the lower portion of the further expandable liner pipe is expanded to further extend the tubular liner into the second wellbore section. This procedure may be repeated as desired until the drilling of the second wellbore section has been completed and the tubular liner extends to at or near the bottom of the second wellbore section.

[0013] The assembly that is lowered into the wellbore suspended from the cable must have a maximum external diameter that is less than the internal diameter, d_1 , of the tubular liner of the first wellbore section thereby allowing the drilling assembly to pass through the tubular liner to the bottom of the first wellbore section. Preferably, the tubular liner of the first wellbore section has an inner diameter, d_1 , of 5 to 10 inches (13 to 25 cm). Preferably, the maximum outer diameter of the drilling assembly is at least 0.5 inches (1.3 cm), more preferably, at least 1

inch (2.5 cm) less than the inner diameter of the casing. It is therefore envisaged that the assembly may drill a second section of wellbore having a diameter, d_2 , less than the internal diameter, d_1 , of the tubular liner of the first wellbore section such that the tubular liner of the second wellbore section is of reduced internal diameter compared with the tubular liner of first wellbore section. However, it is desirable for the tubular liner of the wellbore to have a substantially uniform internal diameter along the entire length thereof (hereinafter "monobore well"). Thus, in a preferred aspect of the present invention, the drill bit of the apparatus is provided with a "hole-opener". By "hole-opener" is meant a device used to enlarge the size of a borehole, having cutting surfaces, for example, teeth, arranged on its outside circumference to cut the formation as it rotates. Thus, the hole-opener may be used to increase the diameter of the second wellbore section. Suitably, the hole-opener may enlarge the second wellbore section during drilling of the second wellbore section, i.e. as the hole-opener is moved downwardly through the wellbore. Alternatively, the hole-opener may be actuated to enlarge the second wellbore section by interrupting the drilling step and moving the assembly upwardly through the open hole. Suitable hole-openers include conventional under reamers and eccentric drill bits. Preferably, an under reamer is located above the drill bit of the assembly, preferably, immediately above the drill bit. Suitably, the under reamer has radially extendible cutting surfaces that may be extended into contact with the wellbore wall to ream the wellbore.

[0014] It is envisaged that the diameter of the second wellbore section may be enlarged to substantially the same diameter, d_3 , as the first wellbore section (where d_3 is the diameter of the first wellbore section prior to it being lined with the tubular liner). Preferably, the tubular liner of the first wellbore section may be an expandable liner that is expanded against the wall of the first wellbore section using a conventional expansion tool. Likewise, the expandable liner pipe and sealed connections between the liner pipe and the tubular liner may be expanded against the wellbore wall. As the sealed connections between the liner pipes are formed by expanding an upper portion of liner pipe into the lower portion of the tubular liner, these connections are of double thickness. Accordingly, the internal diameter of the tubular liner is reduced at the connections. It is also envisaged that the tubular liner of the first wellbore section may be cemented into place in the wellbore with the thickness of the cement corresponding to the increased thickness of the sealed connections. Suitably, cement is omitted from the lower portion of the first wellbore section, for example, the bottom 0.5 to 20 feet (0.15 to 6 m) to allow for accommodation of the first sealed connection. For example, the lower portion of the first wellbore section may be provided with a crushable spacer, for example a spacer formed of expandable polystyrene. Accordingly, the sealed connections may be expanded against the wall of the second wellbore section with the portions of the liner pipe be-

tween the sealed connections being expanded to the same internal diameter as the sealed connections resulting in a true monobore well. As will be evident to the person skilled in the art, there will be an annular gap between the wellbore wall and the portions of liner pipe between the sealed connections. This annular gap may be filled by pumping a cement into the wellbore in a conventional manner prior to expanding the liner pipe. Thus, the cement flows through the interior of the liner pipe and into the annular gap between the liner pipe and the wall of the wellbore. The liner pipe is then expanded from the bottom upwards thereby applying pressure to the cement that is present in the annular gap and forcing excess cement to flow upwardly through the annular gap and out from the top of the liner pipe into the wellbore. Once the cement has set, a pressure seal is formed between the expanded liner pipe and the cement.

[0015] Alternatively, the second wellbore section may be reamed such that its diameter in the intervals where it is desired to form the sealed connections (d_4) is greater than the diameter in the intervals between the sealed connections (d_3) wherein the difference between the diameters d_4-d_3 is sufficient to accommodate the increased thickness of the sealed connections and wherein d_3 is as defined above. Preferably, the lower portion, for example, the bottom 0.5 to 20 feet (0.15 to 6 m) of the first wellbore section is also reamed to diameter d_4 . Accordingly, both the sealed connections and the portions of liner therebetween may be expanded against the wellbore wall without any restriction in the internal diameter of the wellbore in the vicinity of the sealed connections resulting in a true monobore well.

[0016] Preferably, the first wellbore section is drilled in a conventional manner using a drill string having a drill bit provided with a hole-opener on the lower end thereof. The hole-opener is used to increase the diameter of the lower portion of the first wellbore section to diameter d_4 . Suitable hole-openers are as described above. Preferably, a conductor is pushed or drilled into the upper part of the first wellbore section during the drilling of the first wellbore section. Once the drilling of the first wellbore section is complete, a casing is run from the surface to the bottom of the first wellbore section in a conventional manner such that the lower end of the casing lies in the reamed lower portion of the first wellbore section. Thus, the casing constitutes the tubular liner for the first wellbore section. Where the casing is cemented into place in the first wellbore section, the thickness of the layer of cement, preferably corresponds to the difference between the diameters d_4-d_3 . Suitably, the reamed lower portion of the first wellbore section is provided with a crushable spacer, for example, a spacer formed of expandable polystyrene. This crushable spacer allows the sealed connection that is formed between the first expandable liner pipe and the casing to be expanded against the wall of the reamed lower portion of the first wellbore section. Alternatively, the casing of the first wellbore section may be an expandable casing that is ex-

panded against the conductor and against the wall of the wellbore using a conventional expansion tool, for example an expandable mandrel in which case the crushable spacer may be omitted.

[0017] The drilling assembly is then lowered to the bottom of the first wellbore section suspended on a cable and drilling of the second wellbore section is commenced by rotating the drill bit. The drill bit may be configured to drill a hole of greater diameter than its initial diameter. For example, the bit may be a bi-centre bit or an expandable bit such that the bit may pass through the casing of the first wellbore section and then be utilised to drill a bore of larger diameter than the internal diameter of the casing of the first wellbore section. Suitably, the drill bit of the assembly is provided with a hole-opener, for example, an under reamer. Initially, the diameter of the second wellbore section is less than the internal diameter of the casing that constitutes the tubular liner of the first wellbore section. However, the second wellbore section is preferably reamed to a larger diameter by radially extending the cutters of the hole-opener into engagement with the wall of the second wellbore section. This may be achieved during drilling of the second wellbore section or by moving the assembly back through the open hole. Suitably, the second wellbore section may be enlarged until its diameter corresponds to that of the reamed lower portion of the first wellbore section. Thus, the diameter of the second wellbore section may be substantially uniform along the entire length thereof. Alternatively, the second wellbore section may be enlarged such that its diameter alternates between longer intervals having a diameter that corresponds to the diameter of the unreamed upper portion of the first wellbore section and shorter intervals having a diameter that corresponds to that of the reamed lower portion of the first wellbore section. Preferably, the difference between the diameters of the shorter and longer intervals is sufficient to accommodate the sealed connections. Suitably, the shorter intervals that are reamed to a larger diameter to accommodate the sealed joints have a length of from 0.5 to 20 feet (0.15 to 6 m) (i.e. the preferred length of the upper portion of the expandable liner pipe that is expanded into the tubular liner to form the sealed joint). Suitably, the longer intervals correspond to the length of the lower portion of the expandable liner pipe that is expanded to extend the tubular liner into the second wellbore section.

[0018] The length of the each liner pipe that is run into the wellbore along the cable is dependent upon parameters such as the geology of the formation, the pore pressure of the formation, wellbore stability and any loss of drilling fluid to the formation (lost circulation) and may be in the range 10 to 1000 feet (3 to 305 m). Thus, if the wellbore is of low geomechanical stability or if the wellbore is being drilled through a lost circulation zone, it will be necessary to frequently interrupt drilling of the second wellbore section to extend the tubular liner with relatively short expandable liner pipes. However, where the wellbore is geomechanically stable and no lost circulation

zone is encountered, it may be possible to drill a longer interval of the second wellbore section before it becomes necessary to extend the liner with relatively long expandable liner pipes.

[0019] It is envisaged that the expandable liner pipe may be formed of metal, for example, a low carbon steel or any other steel alloy, or from an expandable plastic material. When the expandable liner pipe is metal and is expanded against the wall of the second wellbore section, a metal to rock seal is obtained. Preferably, the expandable liner pipe is provided with a coating of a resilient material, preferably an elastomeric material, to provide an improved seal with the rock. Preferably, the elastomeric material is resistant to the well environment, i.e. temperature, pressure, well fluids, and the like. Suitably, the elastomeric material is selected from rubber (for example, silicone rubber), polymers of ethylene-propylene diene monomer (EPDM), polytetrafluoroethylene, polyphenylene sulfide, and perfluoroelastomers. Typically, the thickness of the coating of resilient material is in the range 0.05 to 2 inches (0.13 to 5 cm), for example, about 0.5 inch (1.3 cm).

[0020] The thickness of the wall of the expandable liner pipe decreases as it is expanded. Where the expandable liner pipe is comprised of metal, the required thickness of the wall after expansion is a function of the diameter of the wellbore and the yield and tensile strength of the metal forming the expandable liner pipe. In general, as the wellbore diameter increases it is necessary to increase the thickness of the wall of the expandable metal liner pipe in order for the expanded pipe to apply sufficient force to the wall of the wellbore to seal the open hole. Preferably, the thickness of the wall of the expanded metal liner pipe is in the range 0.25 to 1 inches (0.64 to 2.54 cm) for an expanded pipe having an internal diameter in the range 6 to 8 inches (15 to 20 cm).

[0021] It is envisaged that the expandable liner pipe may be capable of being deformed such that in its deformed state the liner pipe can pass through a restriction in a wellbore to the location where the liner pipe is to be expanded to extend the tubular liner of the wellbore. Once at the desired location in the wellbore, the liner pipe may be reformed into a substantially tubular shape having an outer diameter greater than the minimum restriction in the wellbore and the reformed pipe may then be expanded to extend the tubular liner without exceeding the maximum expansion ratio for the expandable liner pipe. The maximum expansion ratio for the reformed pipe is generally about 30%. The expansion ratio from the deformed to the expanded state may be in the range 30 to 100%.

[0022] Preferably, the liner pipe is deformed into a longitudinally corrugated pipe. It is also envisaged that the liner pipe may be deformed into any other shape that is capable of passing through the minimum restriction in the wellbore. Suitably, the liner pipe may be deformed to a size smaller than the minimum restriction in the wellbore using a set of rollers located above the wellhead. Preferably, the reformable and expandable liner pipe is pro-

vided with a coating of a resilient material, as described above.

[0023] The liner pipe can comprise sections of pipe connected together by connections, such as, for example, screw connections. Generally, the whole of the liner pipe, including such screwed connections are expanded. However, expanding a screw connection in the liner string may cause the connection to be unmade. Therefore, in some cases, it may be preferable not to expand screw connections in the liner string.

[0024] The deformed metal liner pipe may be reformed and expanded using the expansion means of the assembly. When the expansion means of the assembly is used to reform and expand a deformed metal liner pipe, for example, a longitudinally corrugated metal liner pipe, the expansion means may reform the entire pipe prior to expanding the pipe to extend the tubular liner of the wellbore. However, it is preferred that the expansion means reforms and expands the deformed metal liner pipe in a single operation. If desired, and as suggested above, the liner pipe may be expanded only between any screw connections in which case it is preferred that the portions of the liner pipe that form any such screwed connections are substantially tubular having an outer diameter that allows the connections to pass through the tubular liner of the first wellbore section.

[0025] The drilling assembly is lowered into the wellbore suspended from a cable. Preferably, the cable is provided with a plurality of cable connection means spaced apart along the length thereof, for example, at 250 to 1000 feet (76 to 305 m) intervals. Accordingly, as the second wellbore section is drilled to a greater length, the upper and lower lengths of the cable may be disconnected using the closest connection means to the surface or a cable connection means that has yet to enter the wellbore.

[0026] Preferably, the cable is a reinforced cable, for example, a reinforced steel cable. The cable may be connected to the drilling assembly by means of a connector, preferably, a releasable connector. Preferably, the cable encases one or more wires and/or segmented conductors for transmitting electricity or electrical signals from the surface to the assembly (hereinafter "conventional cable"). However, the assembly may be suspended from a conventional reinforced cable with electricity and/or electrical signals being transmitted from the surface to the assembly via a separate electrical cable.

[0027] The cable from which the drilling assembly is suspended may also be a "hybrid cable" comprising tubing suitable for conveying a fluid wherein at least one electrical conductor wire and/or segmented electrical conductor is embedded in the wall of the tubing. Preferably, the hybrid cable comprises an inner tube, a layer of an insulation material having at least one electrical conductor wire and/or segmented conductor embedded therein, an intermediate fluid barrier layer and an outer flexible protective sheath. Suitably, the inner tube and outer intermediate fluid barrier layer are comprised of

steel. Suitably the insulation material is a flexible material, preferably a plastic or rubber material. Suitably, the outer protective sheath is steel braiding. Preferably, the electrical conductor wire(s) and/or segmented conductor(s) embedded in the layer of insulation material are coated with an electrical insulation material. Preferably, the internal diameter of the inner tube of the hybrid cable is in the range 0.2 to 5 inches (0.5 to 13 cm), preferably 0.3 to 1 inches (0.8 to 2.54 cm).

[0028] Preferably, the assembly that is suspended from the cable comprises an elongate housing, preferably, a tubular housing. Suitably, the tubular housing is connected to the cable via a releasable connection means. Preferably, an electric motor and a drive means for the drill bit are located within the housing of the assembly. The electric motor powers the drive means for the drill bit with electricity being transmitted to the electric motor from the surface via an electrical conductor wire and/or a segmented conductor that is either embedded in the cable from which the assembly is suspended or in a separate electric cable. Preferably, the means for driving the drill bit also drives the optional hole-opener. Typically, the means for driving the drill bit may be a rotor. The housing of the assembly may also be provided with an electrically actuated traction means for providing thrust to the drill bit.

[0029] Preferably, the housing of the assembly has a fluid passage that is in fluid communication with ports in the drill bit and with ports in the optional hole-opener. Suitably, the housing is provided with a pumping means, for example, a suction pump, that is used to pass a fluid through the passage in the housing to the ports in the drill bit (and the ports in optional hole-opener). The fluid cools the cutting surfaces of the drill bit (and optional hole-opener) and also transports drill cuttings away from the cutting surfaces entrained in the fluid. Preferably, the pumping means is electrically powered with electricity being transmitted to the pumping means via an electrical conductor wire and/or a segmented conductor.

[0030] Typically, a drilling mud is pumped through the passage of the drilling assembly and out over the cutting surfaces of the drill bit via the pumping means. Where the drilling assembly is suspended from a hybrid cable the drilling mud may be pumped from the surface through the inner tube of the hybrid cable and through the passage in the assembly to the ports in the drill bit and out over the cutting surfaces. Thus, the inner tube of the hybrid cable is in fluid communication with the passage in the housing of the assembly. The drilling mud having drill cuttings entrained therein then flows back to the surface over the outside of the assembly and through the annulus formed between the wellbore wall and the hybrid cable ("conventional circulation" mode). Alternatively, the drilling mud may be passed to the drilling assembly through the annulus formed between the hybrid cable and the wall of the wellbore and an entrained cuttings stream may be transported away from the drilling assembly through the inner tube of the hybrid cable ("reverse circulation"

mode). Thus, the assembly is provided with at least one inlet for the drilling mud that is in fluid communication with the ports in the drill bit (and optional hole-opener) and also with the inner tube of the hybrid cable. Accordingly, the passage in the housing of the assembly has a branch point with a first branch passage that is in fluid communication with the ports and a second branch passage that is in fluid communication with the inner tube of the hybrid cable.

[0031] Where the assembly is suspended from a conventional reinforced cable a drilling mud may be pumped from the surface to the bottom of the wellbore via a hydraulic line (coiled tubing or a jointed pipe string). This hydraulic line is preferably arranged in parallel with the conventional cable rather than concentrically about the conventional cable. Suitably, this hydraulic line is in fluid communication with a passage in the housing of the assembly with the drilling mud flowing through this passage and out through ports in the drill bit (and the optional hole-opener). The drilling mud then flows back to the surface over the outside of the assembly and through the interior of the tubular liner.

[0032] Where the drilling assembly is used to drill a second wellbore section through a producing formation, it is envisaged that the cutting surfaces on the drill bit may be cooled by the fluids that are produced from the formation into the wellbore and that drill cuttings may be transported away from the cutting surfaces entrained in the produced fluid. Accordingly, there is no requirement to pass a drilling mud from the surface to the drilling assembly. By "produced fluid" is meant produced liquid hydrocarbons and/or produced water, preferably produced liquid hydrocarbons. Where the produced fluid comprises produced liquid hydrocarbons, hydrocarbon fluid may be produced from the wellbore during drilling of the section wellbore section. The pressure of the hydrocarbon-bearing formation may be sufficiently high that the produced fluid having drill cuttings entrained therein flows to the surface by means of natural energy. If necessary, the wellbore may be provided with artificial lift. It is envisaged that pumping means and fluid passage through the assembly may be omitted. However, it is preferred that the assembly is provided with a pumping means for drawing produced fluids through an inlet in the housing and through a passage in the assembly that is in fluid communication with ports in the drill bit (and optional hole-opener).

[0033] The method of the present invention may be also be used to drill a new section of wellbore from a selected location in an existing cased wellbore that has a hydrocarbon fluid production conduit arranged in sealing relationship with the wall of the casing. The casing of the existing wellbore constitutes the tubular liner. The new wellbore section may be an extension of the existing wellbore or a side track wellbore or lateral wellbore. Accordingly, it is preferred that the drilling assembly and the expandable liner pipe are capable of passing into the wellbore through the production conduit. This is advan-

tageous in that there is no requirement to pull the production conduit from the wellbore.

[0034] Generally, a production conduit has an inner diameter of 2.5 to 8 inches (6.4 to 20.3 cm), preferably 3.5 to 6 inches (9 to 15 cm). Preferably, the maximum outer diameter of the drilling assembly and of the expandable liner pipe is at least 0.5 inches (1.3 cm), more preferably, at least 1 inch (2.5 cm) less than the inner diameter of the production conduit. Preferably, the drill bit of the assembly is provided with a hole-opener, thereby allowing the new wellbore section that is drilled from the selected location to be enlarged to a greater diameter than the inner diameter of the production conduit. Preferably, the new wellbore section is enlarged to substantially the same diameter as the diameter of the existing wellbore. Advantageously, the expandable liner pipe is a deformed expandable liner pipe of the type discussed above, thereby allowing the liner pipe to be expanded to extend the tubular liner without exceeding its maximum expansion ratio.

[0035] Preferably, the drilling assembly is provided with an electrically operated steering means, for example, a steerable joint, which is used to adjust the trajectory of the second wellbore section as it is being drilled. This steering means is electrically connected to equipment at the surface via an electrical conductor wire or a segmented conductor embedded in the cable from which the assembly is suspended or in a separate electrical cable.

[0036] Preferably, the drilling assembly may be provided with sensors which are electrically connected to recording equipment at the surface via an electrical conductor wire or segmented electrical conductor embedded in the cable from which the assembly is suspended or in a separate electrical cable. Suitably, the sensors are located in proximity to the cutting surfaces on the drilling assembly. If desired, sensors may also be located along the cable. Such sensors may, for example, include at least one location sensor.

[0037] Preferably, the drilling assembly additionally comprises an electrically powered traction means for displacing the drilling assembly within the wellbore. The traction means may be used to advance the drilling assembly through the second wellbore section as it is being drilled, to take up the reactive torque generated by the means for driving the drill bit (and the optional hole-opener), to move the assembly upwardly through the wellbore, and to move the assembly through the expandable liner pipe so that the expansion means expands the liner pipe. Electricity is transmitted to the traction means via an electrical conductor wire and/or segmented conductor encased in the cable from which the assembly is suspended or encased in a separate electrical cable. Suitably, the traction means of the assembly comprises a first (upper) slip and a second (lower) slip that are connected either directly or indirectly by a piston in such a way that operation of the piston can move the slips towards or away from each other. The piston of the traction means comprises a cylinder that fits within a tube in which it moves

up and down. This traction means may be operated to move the assembly upwardly through the wellbore by setting the upper slip to grip the inner wall of the tubular liner or open hole, unsetting the lower slip, moving the cylinder of the piston such that the second (lower) slip is moved upwardly towards the first (upper) slip, setting the second (lower) slip and unsetting the first (upper) slip. The cylinder is then moved back to its original position within the tube moving the first (upper) slip away from the second (lower) slip. The first (upper) slip is then set and the second (lower) slip unset. This operation may be repeated a plurality of times to move the assembly upwards in the wellbore. The traction means may also be operated to move the assembly downwardly through the wellbore by setting the lower slip and moving the cylinder of the piston to move the first (upper) slip towards the second (lower) slip, setting the upper slip, unsetting the lower slip and moving the cylinder to move the second (lower) slip away from the first (upper) slip and then the second (lower) slip is set and the first (upper) slip unset. This operation may be repeated a plurality of times to move the assembly downwards in the wellbore. Preferably, the movement of the piston and the setting of the upper and lower slips are electrically powered. Alternatively, the traction means of the assembly may comprise wheels or rollers which engage with and move the drilling assembly over the wall of the open hole or over the wall of the tubular liner.

[0038] The cable traction means of the drilling assembly that is used to run the expandable liner pipe into the wellbore supports the expandable liner pipe and moves it along the cable, i.e. through the wellbore relative to the cable. The cable traction means is preferably provided with wheels or rollers that run along the cable but may instead, or in addition, have wheels or rollers that run against the tubular liner of the wellbore. Where the wheels or rollers run against the tubular liner, the cable may pass through the traction means and the traction means extends beyond the upper end of the expandable liner pipe so that the wheels or rollers can run against the tubular liner. Preferably, the cable traction means is electrically powered. Suitably, the cable traction means is inductively coupled to the cable (where the cable has at least one electrical wire or segmented electrical cable). Alternatively, the cable traction means may be powered by a second electrical cable that extends to the surface. Suitably, the cable traction means is provided with a radially extendible gripping member, preferably, an electrically powered radially extendible gripping member, that may be actuated for gripping the internal wall of the expandable liner pipe. Suitably, the gripping member comprises at least one radially extendible "slip" that has teeth or other gripping elements. Preferably, the cable traction means is provided with a plurality of "slips", preferably 2 to 4 slips. Suitable "slips" for use with the liner pipe would be well known to the person skilled in the art. Preferably, the slips are moveable over the inner surface of the liner pipe. When the cable traction means has run a liner pipe

from the surface to the bottom of the cable, the slips may be used to move the liner pipe downwardly through the wellbore with respect to the cable traction means so that the liner pipe is disposed concentrically about the drilling assembly and held by slips or a stop on the drilling assembly. The slips of the cable traction means may then be unset and the cable traction means may be moved upwardly along the cable. Suitably, sensors are provided on the drilling assembly and optionally on the traction means. The sensors can be used to ensure that the liner is supported on the assembly at the desired location in the wellbore with the upper portion of the liner pipe overlapping the lower portion of the tubular liner and the lower portion of the liner pipe extending into the open hole.

[0039] Suitably the expansion means may be an expandable packer. Suitably, the length of the expandable packer may correspond to the length of the liner pipe so that the expandable packer is capable of simultaneously expanding the entire expandable liner pipe. However, the expandable packer may also have a length that is substantially less than the length of the expandable liner pipe. Preferably, the expandable packer may be moved downwardly through the liner pipe to expand the liner pipe in stages. Thus, the expandable packer is first inflated to expand the upper portion of the liner pipe into the tubular liner to form a sealed joint therebetween. The packer is then deflated and is moved downwardly through the expandable liner pipe until the packer is arranged immediately below the sealed joint. The packer is then inflated to expand a further portion of the liner pipe before being deflated and this procedure is repeated until the entire liner pipe has been expanded. It is envisaged that the traction means of the assembly may move the assembly and hence the expandable packer downwardly through the wellbore. However, it is preferred that the length of the open hole is controlled so that when the expandable packer is located in the upper portion of the expandable liner pipe, the drill bit is located at the bottom wellbore. Accordingly, the deflated packer may be moved through the liner pipe by actuating the drill bit to drill a further portion of the second wellbore and periodically interrupting the drilling operation to inflate the packer thereby expanding a portion of the liner pipe.

[0040] The expansion means may also be an expandable mandrel that is disposed about the tubular housing of the assembly and is moveable from an upper to a lower position with respect to the housing of the assembly. Suitably, the mandrel is initially located at its upper position with respect to the housing of the assembly, above the expandable liner pipe that is supported by the assembly. The mandrel is then expanded and is moved downwardly through the expandable liner pipe with respect to the housing of the assembly. It is envisaged that the mandrel may be moved downwardly through the expandable liner pipe with respect to the housing via an electrically driven screw mechanism. Typically the bottom of the expandable liner pipe is supported by the assembly. Alternatively, the mandrel may be in a fixed position with respect to the

assembly, with drilling of a further portion of the second wellbore section causing the mandrel to move downwardly through the expandable liner pipe. Thus, once the top of the liner pipe has been expanded to initiate the sealed joint that is formed between the upper portion of the liner pipe and the tubular liner, the radially expandable gripping means of the assembly is retracted to enable the mandrel to move downwardly through the liner pipe as the further portion of the second wellbore section is being drilled.

[0041] The expandable liner pipe may also be expanded using an electrically powered rotatable expansion means having at least one radially extendible member, for example, radially extendible rollers. Preferably, the radially extendible member is electrically actuated. Electricity may be transmitted to the rotatable expansion means via an electrical conductor wire or segmented conductor encased in the cable from which the assembly is suspended or via a separate electric cable. The rotatable expansion means expands the expandable liner pipe by extending the radially extendible member into engagement with the inner wall of the expandable liner pipe and applying pressure to the liner by gradually extending the extendible member whilst rotating the expansion means. Suitably, the expansion means is provided with an electrically powered mechanism for radially extending and retracting the extendible elements. It is envisaged that the expansion means may be rotatable with respect to the housing of the assembly. Alternatively, the entire assembly may be rotated to rotate the expansion means. Typically, it is necessary to move the rotatable expansion means downwardly through the expandable liner pipe. This may be achieved by actuating the traction means of the assembly to move the assembly and hence the expansion means through the expandable liner pipe. Alternatively, the length of the open hole may be controlled so that when the drill bit is located at the bottom of the wellbore, the rotatable expansion means is located at the top of the expandable liner pipe. Accordingly, the rotatable expansion means may be moved downwardly through the liner pipe as the drill bit drills a further portion of the second wellbore section.

[0042] Preferably, the assembly is provided with sensors for monitoring the expansion of the pipe and the position of the expansion means in the wellbore.

[0043] Preferably the cable traction means is actuated to collect a further section of liner pipe from the surface during the expansion operation so that the method of drilling and lining the wellbore becomes a seamless operation.

[0044] Preferably, the liner pipe may be introduced from the surface into the wellbore using a lubricator. The term "lubricator" is well known to the person skilled in the art, and means a specially fabricated length of casing or tubing that is arranged at the surface and is used to run tools into a wellbore. Typically, the lubricator is located immediately above a surface valve that is used to seal off the wellbore.

[0045] Accordingly, in a preferred embodiment of the method of the present invention there is provided a method of drilling a second wellbore section from a first wellbore section that is lined with a tubular liner and of extending the tubular liner into the second wellbore section, the method comprising:

(a) drilling the second wellbore section from the first wellbore section using a drilling assembly suspended from the lower end of a cable that encases at least one electrical wire or segmented electrical conductor wherein the assembly comprises an expansion means, an electric motor, a drive means and a drill bit, the cable extends from a surface hoist means through a lubricator and a surface valve into the wellbore and is provided with at least one releasable cable connection means and with a cable traction means that is moveable along the length of the cable, the method comprising:

(b) interrupting drilling of the second wellbore section, actuating the hoist means to pull the cable and hence the assembly upwardly through the wellbore until the cable connection means is positioned within the lubricator;

(c) moving the cable traction means upwardly along the cable into the lubricator to a position below the cable connection means;

(d) closing the surface valve to seal off the wellbore, disconnecting the lubricator, and disconnecting the cable connection means;

(e) arranging an expandable liner pipe concentrically about the cable supported on the traction means;

(f) reconnecting the cable connection means and reconnecting the lubricator;

(g) opening the surface valve and moving the cable traction means downwardly along the cable so that the expandable liner pipe that is supported on the cable traction means passes through the surface valve and into the wellbore to a position where the upper portion of the expandable liner pipe overlaps the lower portion of the tubular liner and the lower portion of the expandable liner pipe extends into the open hole of the second wellbore section;

(h) actuating the expansion means of the assembly to expand the upper portion of the expandable liner pipe into the lower portion of the tubular to form a sealed connection therebetween and to expand the lower portion of the expandable liner pipe to extend the tubular liner into the second wellbore section;

(i) optionally recommencing drilling of the second wellbore section and repeating steps (b) to (h).

[0046] Where the expandable liner pipe is introduced into the wellbore using a lubricator, the external diameter of the expandable liner pipe will be limited by the internal diameter respectively of the lubricator. It is envisaged that the length of the liner pipe may be limited by the length of the lubricator. However, it is also envisaged that

the wellbore may be provided with a downhole valve. This downhole valve is closed before disconnecting the lubricator and cable connection means. A string of liner pipe is then arranged concentrically about the lower end of the cable and is lowered into the wellbore in a conventional manner before actuating the cable traction means to grip the internal wall of the liner string. The cable connection means and lubricator are then reconnected, the downhole valve is re-opened and the liner string is moved downwardly with respect to the cable until the liner string is in the desired location in the wellbore.

[0047] It is also envisaged that the drilling assembly may be provided with a radially extendible cutter for cutting a section of liner from the liner pipe and that this cut section of liner pipe is then expanded to form a sealed joint with the tubular liner and to extend the tubular liner. Suitably, the cut section of liner is supported on the assembly prior to being expanded using the expansion means of the assembly. The drilling operation is then recommenced to drill a further section of liner before interrupting the drilling operation to cut a further section of liner from the liner pipe to further extend the tubular liner.

[0048] Where the cable is a hybrid cable, the cable connection means may be provided with a passage so that fluid, for example, drilling mud may flow through the cable connection means. Alternatively, the cable connection means may be provided with an outlet for the fluid.

[0049] In yet a further aspect of the present invention there is provided an apparatus for drilling and lining a wellbore the apparatus comprising a remotely controlled electrically powered drilling assembly suspended from a cable having at least one electrical wire and/or segmented electrical conductor embedded therein for transmitting electricity or electrical signals from the surface to the assembly wherein the assembly comprises an expansion means and an electrically driven drill bit and the cable is provided with a traction means that is moveable along the cable for delivering an expandable liner pipe from the surface to the assembly.

[0050] The invention will now be described with reference to Figures 1 to 14 in which;

Figure 1 is a schematic cross-section of apparatus for use in the method of the present invention,
 Figures 2 to 10 are schematic cross-sectional drawings illustrating the method of the present invention
 Figures 11 and 12 are schematic cross-sectional drawings illustrating the use of an expandable packer to expand the expandable liner pipe, and
 Figures 13 and 14 are schematic cross-sectional drawings illustrating the use of a radially expandable mandrel to expand the expandable pipe.

[0051] In Figure 1 is shown the apparatus of the present invention suspended from a hybrid cable 1. The apparatus comprises an expansion means 2, a traction means 3, a pumping means 4, an electric motor 5, a drive means (not shown) and a drill bit 6. The electric motor 5

powers the drive means that rotates the drill bit 6. The traction means 3 comprises a first slip 7 and a second slip 8 connected by a piston 9 and provides the necessary thrust to the drill bit.

[0052] In Figure 2 a first wellbore section 10 has been drilled through a subterranean formation and a casing (tubular liner) 11 has been run into the bottom thereof in a conventional manner. Drilling of a second wellbore section 12 from the first wellbore section 10 is commenced using the assembly of Figure 1 suspended from a hybrid cable. The hybrid cable comprises an upper length 13 and lower length 14 of cable joined via a releasable connection means 15. The hybrid cable passes from a surface winch means 16 through a lubricator 17 and valve 18 into the wellbore. Once the assembly has reached the bottom of the first wellbore section, the drive means is actuated such that the drill bit begins to drill the second wellbore section. Figure 3 shows the second wellbore section drilled to a greater depth.

[0053] In Figure 4, the hybrid cable has been partially pulled from the wellbore using the winch means 16 until the cable connection means 15 lies within the lubricator 17. The surface valve 18 is then closed.

[0054] In Figure 5, the lubricator 17 and cable connection means 15 have been disconnected and the lubricator 17 and the upper length 13 of the hybrid cable have been lifted away from the surface valve 18. An expandable liner pipe 19 has been arranged concentrically about the lower length 14 of the hybrid cable supported on a traction means 20 that is moveable along the cable ("cable traction means").

[0055] In Figure 6, the lubricator 17 has been lowered over the surface valve and the cable connection means 15 has been reconnected. The lubricator is then reconnected as shown in Figure 7. Thus, the cable traction means 20 is disposed in the annular space between the hybrid cable and the expandable liner pipe 19. The cable traction means 20 is provided with an external gripping member (not shown) that grips the inner wall of the liner pipe 19. The cable traction means 20 is also provided with tractor wheels (not shown) that are movable over the outer surface of the hybrid cable. The cable traction means 20 is electrically powered and is preferably inductively coupled to the hybrid cable. As the cable traction means moves downwardly along the hybrid cable the liner pipe moves downwardly through the wellbore until the liner pipe lies immediately above the assembly, as shown in Figure 8. The expandable liner pipe 19 is then walked downwardly through the wellbore with respect to the cable traction means by moving the external gripping member over the internal surface of the liner pipe until the upper portion of the expandable liner pipe 19 overlaps the lower portion of the casing 11 of the first wellbore section 10 and the lower portion of the expandable liner pipe 19 extends into the open hole 12. The liner pipe is now arranged concentrically about the assembly. The expansion means of the assembly is radially expanded to expand the upper portion of the expandable liner pipe

19 into the lower portion of the casing 11 (the tubular liner for the first wellbore section) to form a sealed joint therebetween and to expand the lower portion of the expandable liner pipe to extend the tubular liner into the second wellbore section. The expansion means is then radially retracted as shown in Figure 9. During the drilling of a further portion of the second wellbore, the cable traction means 20 is moved upwardly along the cable 14 as shown in Figure 10. The procedure outlined above is then repeated such that a further expandable liner pipe is introduced into the wellbore along the cable and an upper portion of the further expandable liner pipe is expanded into the lower portion of the tubular liner to further extend the tubular liner into the second wellbore section.

[0056] Figures 11 and 12 illustrate an assembly according to the present invention comprising a radially expandable packer 21. Suitably, the packer 21 may be hydraulically expanded. Prior to expansion of the packer 21, the lower gripping member 8 of the traction means 3 is radially extended to grip the wall 22 of the wellbore. During this operation, the expandable liner pipe 19 is supported on the assembly. Typically, the expandable packer is initially located at the top of the liner pipe so that a sealed joint 23 is formed between the liner pipe 19 and the tubular wellbore liner 24 upon expansion of the packer 21. The packer is then retracted and the traction means actuated to move the assembly downwardly through the wellbore until the packer is located immediately below the expanded section of the liner pipe. The packer is then expanded to expand a further section of liner pipe and the above procedure is repeated until the entire liner pipe has been expanded.

[0057] Figures 13 and 14 illustrate an assembly according to the present invention comprising a radially expandable mandrel 25. Initially, the expandable mandrel is located above the expandable liner pipe 19 with the liner pipe supported on the assembly above the traction means 3. The mandrel 25 is expanded as shown in Figure 14 and is moved downwardly through the expandable liner pipe 19 as the drill bit 6 extends the wellbore. Simultaneously, the traction means 3 is operated to move the assembly through the wellbore. The traction means 3 also provides thrust to the drill bit 6.

Claims

1. A method of drilling a second wellbore section (12) from a first wellbore section (10) that is lined with a tubular liner (11) and of extending the tubular liner into the second wellbore section, the method comprising:

(a) drilling the second wellbore section (12) from the first wellbore section (10) using a remotely controlled electrically powered drilling assembly that is suspended from a cable (1) that extends from the surface wherein the cable comprises

an upper (13) and a lower (14) length of cable connected by a cable connection means (15) and the drilling assembly comprises an expansion means (2), a traction means (3), and an electrically actuated drill bit (6) and wherein electricity is transmitted to the assembly via at least one electrical wire and/or segmented electrical conductor that extends from the surface to the assembly;

(b) introducing an expandable liner pipe (19) into the wellbore and

(c) actuating the expansion means (2) of the assembly to expand the upper portion of the expandable liner pipe (19) into the lower portion of the tubular liner (11) to form a sealed connection therebetween

characterised in that

(d) the expandable liner pipe (19) is introduced into the wellbore by disconnecting the cable connection means (15) at the surface to separate the upper (13) and lower (14) lengths of cable, arranging the expandable liner pipe (19) concentrically about the upper (13) or lower (14) length of cable, reconnecting the cable connection means (15) to rejoin the upper (13) and lower (14) lengths of cable and running the expandable liner pipe (19) into the wellbore supported on a cable traction means (20) that is moveable along the cable; and

(e) actuating the expansion means (2) of the assembly to expand the lower portion of the expandable liner pipe (19) to extend the tubular liner; and

(f) optionally repeating the above-mentioned steps.

2. A method as claimed in claim 1 in which the cable is a hybrid cable comprising tubing suitable for conveying a fluid having at least one electrical conductor wire and/or segmented electrical conductor embedded in the wall of the tubing and drilling mud is passed through the cable.

3. A method as claimed in claim 1 or claim 2 in which the drilling assembly and expandable liner pipe are passed through a production conduit in the first wellbore section prior to drilling the second wellbore section.

4. A method of drilling a second wellbore section (12) from a first wellbore section (10) that is lined with a tubular liner (11) and of extending the tubular liner into the second wellbore section, the method comprising:

(a) drilling the second wellbore section (12) from the first wellbore section (10) using a drilling assembly suspended from the lower end of a cable

(1) that encases at least one electrical wire or segmented electrical conductor wherein the assembly comprises an expansion means (2), an electric motor (5), a drive means and a drill bit (6),

characterised in that

(b) the cable extends from a surface hoist means (16) through a lubricator (17) and a surface valve (18) into the wellbore and is provided with at least one releasable cable connection means (15) and with a cable traction means (20) that is moveable along the length of the cable, and further **characterised in that** the method comprises:

(c) interrupting drilling of the second wellbore section (12), actuating the hoist means (16) to pull the cable and hence the assembly upwardly through the wellbore until the cable connection means (15) is positioned within the lubricator (17);

(d) moving the cable traction means (20) upwardly along the cable into the lubricator (17) to a position below the cable connection means (15);

(e) closing the surface valve (18) to seal off the wellbore, disconnecting the lubricator (17), and disconnecting the cable connection means (15);

(f) arranging an expandable liner pipe (19) concentrically about the cable supported on the traction means (20);

(g) reconnecting the cable connection means (15) and reconnecting the lubricator (17);

(h) opening the surface valve (18) and moving the cable traction means (20) downwardly along the cable so that the expandable liner pipe (19) that is supported on the cable traction means passes through the surface valve (18) and into the wellbore to a position where the upper portion of the expandable liner pipe (19) overlaps the lower portion of the tubular liner (11) and the lower portion of the expandable liner pipe extends into the open hole of the second wellbore section (12);

(i) actuating the expansion means (2) of the assembly to expand the upper portion of the expandable liner pipe (19) into the lower portion of the tubular (11) to form a sealed connection therebetween and to expand the lower portion of the expandable liner pipe to extend the tubular liner into the second wellbore section;

(j) optionally recommencing drilling of the second wellbore section and repeating steps (b) to (i).

5. Apparatus for drilling and lining a wellbore the apparatus comprising a remotely controlled electrically powered drilling assembly suspended from a cable (1) having at least one electrical wire and/or seg-

mented electrical conductor embedded therein for transmitting electricity or electrical signals from the surface to the assembly wherein the assembly comprises an expansion means (2) and an electrically driven drill bit (6) **characterised in that** the cable is provided with a cable traction means (20) that is moveable along the cable for delivering an expandable liner pipe (19) from the surface to the assembly.

6. Apparatus as claimed in claim 5 in which the drilling assembly comprises an elongate housing which housing comprises (a) connection means for connecting the assembly to a suspension cable, (b) an electric motor, (c) a drive means for rotating a drill bit.
7. Apparatus as claimed in claim 6 wherein the drive means for rotating the drill bit also drives a hole-opener.
8. Apparatus as claimed in either of claims 6 or 7 further comprising an electrically operated steering means capable of adjusting the trajectory of the wellbore section as it is being drilled.
9. Apparatus as claimed in claim 6 further comprising an electrically powered traction means for displacing the drilling assembly within the wellbore.
10. Apparatus as claimed in claim 6 further comprising a radially extendible cutter for cutting a section of liner from the expandable liner pipe

Patentansprüche

1. Verfahren zum Bohren eines zweiten Bohrlochabschnitts (12) aus einem ersten Bohrlochabschnitt (10), der mit einer röhrenförmigen Auskleidung (11) ausgekleidet ist, und zum Verlängern der röhrenförmigen Auskleidung in den zweiten Bohrlochabschnitt, wobei das Verfahren umfaßt:

(a) Bohren des zweiten Bohrlochabschnitts (12) aus dem ersten Bohrlochabschnitt (10) unter Verwendung einer ferngesteuerten elektrisch angetriebenen Bohreinheit, die an einem Kabel (1) aufgehängt ist, das sich von der Oberfläche erstreckt, wobei das Kabel eine obere (13) und eine untere (14) Länge des Kabels umfaßt, die durch ein Kabelverbindungsstück (15) verbunden sind, und die Bohreinheit ein Expansionsmittel (2), ein Traktionsmittel (3) und einen elektrisch betätigten Bohrkopf (6) umfaßt, und wobei die Elektrizität zu der Einheit über mindestens eine elektrische Leitung und/oder einen segmentierten elektrischen Leiter übertragen wird, der sich von der Oberfläche zu der Anordnung erstreckt;

- (b) Einführen eines erweiterbaren Einsatzrohrs (19) in das Bohrloch und
- (c) Betätigen des Expansionsmittels (2) der Einheit, um den oberen Teil des erweiterbaren Einsatzrohrs (19) in den unteren Teil der röhrenförmigen Auskleidung (11) unter Bildung einer verschlossenen Verbindung dazwischen zu erweitern,
- dadurch gekennzeichnet, daß**
- (d) das erweiterbare Einsatzrohr (19) in das Bohrloch durch Trennen des Kabelverbindungsmittels (15) an der Oberfläche, um die obere (13) und untere (14) Länge des Kabels zu trennen, eingeführt wird, Anordnen des erweiterbaren Einsatzrohrs (19) konzentrisch über der oberen (13) oder unteren (14) Länge des Kabels, Wiederverbinden des Kabelverbindungsmittels (15), um die oberen (13) und unteren (14) Längen des Kabels wieder zu verbinden, und Einführen des erweiterbaren Einsatzrohrs (19) in das Bohrloch, das von einem Kabeltraktionsmittel (20) getragen wird, das entlang des Kabels beweglich ist; und
- (e) Betätigen des Expansionsmittels (2) der Einheit, um den unteren Teil des erweiterbaren Einsatzrohrs (19) zu erweitern, um die röhrenförmige Auskleidung zu verlängern; und
- (f) gegebenenfalls Wiederholen der obengenannten Schritte.
2. Verfahren nach Anspruch 1, wobei das Kabel ein Hybridkabel ist, umfassend Rohre, die zum Fördern einer Flüssigkeit geeignet sind, mit mindestens einer elektrischen Leitung und/oder einem segmentierten elektrischen Leiter, der in die Wand der Rohre eingebettet ist, wobei Bohrschlamm durch das Kabel geführt wird.
3. Verfahren nach Anspruch 1 oder Anspruch 2, wobei die Bohreinheit und das erweiterbare Einsatzrohr durch einen Produktionskanal in den ersten Bohrlochabschnitt vor dem Bohren des zweiten Bohrlochabschnitts geführt werden.
4. Verfahren zum Bohren eines zweiten Bohrlochabschnitts (12) aus einem ersten Bohrlochabschnitt (10), der mit einer röhrenförmigen Auskleidung (11) ausgekleidet ist, und zum Verlängern der röhrenförmigen Auskleidung in den zweiten Bohrlochabschnitt, wobei das Verfahren umfaßt:
- (a) Bohren des zweiten Bohrlochabschnitts (12) aus dem ersten Bohrlochabschnitt (10) unter Verwendung einer Bohreinheit, die an dem unteren Ende eines Kabels (1) aufgehängt ist, das mindestens eine elektrische Leitung oder einen segmentierten elektrischen Leiter einschließt, wobei die Einheit ein Expansionsmittel (2), einen elektrischen Motor (5), ein Antriebsmittel und einen Bohrkopf (6) umfaßt, **dadurch gekennzeichnet, daß**
- (b) sich das Kabel von einem Oberflächenhebemittel (16) durch eine Schmiervorrichtung (17) und ein Oberflächenventil (18) in das Bohrloch erstreckt, und mit mindestens einem lösbares Kabelverbindungsmittel (15) und mit einem Kabeltraktionsmittel (20), das entlang der Länge des Kabels beweglich ist, ausgestattet ist, und außerdem **dadurch gekennzeichnet ist, daß** das Verfahren umfaßt:
- (c) Unterbrechen der Bohrung des zweiten Bohrlochabschnitts (12), Betätigen des Hebemittels (16) zum Hochziehen des Kabels und daher der Einheit durch das Bohrloch, bis das Kabelverbindungsmittel (15) innerhalb der Schmiervorrichtung (17) positioniert ist;
- (d) Hochbewegen des Kabeltraktionsmittels (20) entlang des Kabels in die Schmiervorrichtung (17) zu einer Position unterhalb des Kabelverbindungsmittels (15);
- (e) Schließen des Oberflächenventils (18) zum Abriegeln des Bohrlochs, Trennen der Schmiervorrichtung (17) und Trennen des Kabelverbindungsmittels (15);
- (f) Anordnen eines erweiterbaren Einsatzrohrs (19) konzentrisch über dem Kabel, wobei es von dem Traktionsmittel (20) getragen wird;
- (g) Wiederverbinden des Kabelverbindungsmittels (15) und Wiederverbinden der Schmiervorrichtung (17);
- (h) Öffnen des Oberflächenventils (18) und Bewegen des Kabeltraktionsmittels (20) nach unten entlang des Kabels, so daß das erweiterbare Einsatzrohr (19), das von dem Kabeltraktionsmittel getragen wird, durch das Oberflächenventil (18) und in das Bohrloch zu einer Position geführt wird, wo der obere Teil des erweiterbaren Einsatzrohrs (19) den unteren Teil der röhrenförmigen Auskleidung (11) überlappt, und sich der untere Teil des erweiterbaren Einsatzrohrs in das offene Loch des zweiten Bohrlochabschnittes (12) erstreckt;
- (i) Betätigen des Expansionsmittels (2) der Einheit, damit sich der obere Teil des erweiterbaren Einsatzrohrs (19) in den unteren Teil der röhrenförmigen Auskleidung (11) erweitert, um dazwischen eine verschlossene Verbindung zu bilden, und damit sich der untere Teil des erweiterbaren Einsatzrohrs erweitert, um die röhrenförmige Auskleidung in den zweiten Bohrlochabschnitt zu erstrecken;
- (j) gegebenenfalls erneutes Beginnen der Bohrung des zweiten Bohrlochabschnitts und Wiederholen der Schritte (b) bis (i).
5. Vorrichtung zum Bohren und Auskleiden eines Bohr-

- lochs, wobei die Vorrichtung umfaßt eine ferngesteuerte elektrisch angetriebene Bohreinheit, die an einem Kabel (1) mit mindestens einer darin eingebetteten elektrischen Leitung und/oder einem segmentierten elektrischen Leiter aufgehängt ist, zum Übertragen von Elektrizität oder elektrischen Signalen von der Oberfläche zu der Einheit, wobei die Einheit ein Expansionsmittel (2) und einen elektrisch angetriebenen Bohrkopf (6) umfaßt, **dadurch gekennzeichnet, daß** das Kabel mit einem Kabeltraktionsmittel (20) ausgestattet ist, das entlang des Kabels beweglich ist zum Befördern eines erweiterbaren Einsatzrohrs (19) von der Oberfläche zu der Einheit.
6. Vorrichtung nach Anspruch 5, wobei die Bohreinheit ein verlängertes Gehäuse umfaßt, wobei das Gehäuse (a) Verbindungsmittel zum Verbinden der Einheit mit einem Aufhängekabel, (b) einen elektrischen Motor, (c) ein Antriebsmittel zum Rotieren eines Bohrkopfs umfaßt.
7. Vorrichtung nach Anspruch 6, wobei das Antriebsmittel zum Rotieren des Bohrkopfs ebenso einen Erweiterungsmeißel antreibt.
8. Vorrichtung nach einem der Ansprüche 6 oder 7, ferner umfassend ein elektrisch betriebenes Lenkungsmittel, das die Bahn des Bohrlochabschnitts, wenn er gebohrt wird, einstellen kann.
9. Vorrichtung nach Anspruch 6, ferner umfassend ein elektrisch angetriebenes Traktionsmittel zum Verschieben der Bohreinheit innerhalb des Bohrlochs.
10. Vorrichtung nach Anspruch 6, ferner umfassend eine radial erweiterungsfähige Schneidvorrichtung zum Schneiden eines Abschnitts der Auskleidung aus dem erweiterbaren Einsatzrohr.

Revendications

1. Procédé de forage d'une seconde section de puits (12) à partir d'une première section de puits (10) tubée avec un tubage tubulaire (11) et d'extension du tubage tubulaire dans la seconde section de puits, le procédé comprenant:
- (a) le forage de la seconde section de puits (12) à partir de la première section de puits (10) à l'aide d'un ensemble de forage électrique contrôlé à distance suspendu depuis un câble (1) qui s'étend depuis la surface, le câble comprenant une longueur de câble supérieure (13) et inférieure (14) connectées par un moyen de connexion de câble (15) et l'ensemble de forage comprenant un moyen d'expansion (2), un moyen de traction (3) et un trépan à actionnement électrique (6) et l'électricité étant transmise à l'ensemble via au moins un câble électrique et/ou conducteur électrique segmenté qui s'étend depuis la surface jusqu'à l'ensemble ;
- (b) l'introduction d'un tubage perdu expansible (19) dans le puits et
- (c) l'actionnement du moyen d'expansion (2) de l'ensemble pour dilater la partie supérieure du tubage perdu expansible (19) dans la partie inférieure du tubage tubulaire (11) afin de former une connexion scellée entre eux, **caractérisé en ce que**
- (d) le tubage perdu expansible (19) est introduit dans le puits en déconnectant le moyen de connexion de câble (15) à la surface pour séparer les longueurs supérieure (13) et inférieure (14) du câble, en disposant le tubage perdu expansible (19) de manière concentrique autour de la longueur supérieure (13) ou inférieure (14) du câble, en reconnectant le moyen de connexion de câble (15) pour joindre à nouveau les longueurs supérieure (13) et inférieure (14) du câble et en dirigeant le tubage perdu expansible (19) à l'intérieur du puits supporté sur un moyen de traction de câble (20) mobile le long du câble ; et
- (e) on actionne le moyen d'expansion (2) de l'ensemble pour dilater la partie inférieure du tubage perdu expansible (19) afin de dilater le tubage tubulaire ; et
- (f) en option, on répète les étapes susmentionnées.
2. Procédé selon la revendication 1, dans lequel le câble est un câble hybride comprenant un tubage approprié au convoyage d'un fluide, dans lequel au moins un câble conducteur d'électricité et/ou un conducteur électrique segmenté est intégré dans la paroi du tubage et la boue de forage passe à travers le câble.
3. Procédé selon la revendication 1 ou 2, dans lequel l'ensemble de forage et le tubage perdu expansible passent à travers un conduit de production dans la première section de puits avant de forer la seconde section de puits.
4. Procédé de forage d'une seconde section de puits (2) à partir d'une première section de puits (10) tubée avec un tubage tubulaire (11) et d'extension du tubage tubulaire dans la seconde section de puits, le procédé comprenant :
- (a) le forage de la seconde section de puits (12) à partir de la première section de puits (10) à l'aide d'un ensemble de forage suspendu depuis l'extrémité inférieure d'un câble (1) qui renferme

au moins un câble électrique ou un conducteur électrique segmenté, l'ensemble comprenant un moyen d'expansion (2), un moteur électrique (5), un moyen de commande et un trépan (6), **caractérisé en ce que**

(b) le câble s'étend d'un moyen de hissage de surface (16) à travers un lubrificateur (17) et une vanne de surface (18) à l'intérieur du puits et est doté d'au moins un moyen de connexion de câble amovible (15) et d'un moyen de traction de câble (20) mobile le long de la longueur du câble, et en outre **caractérisé en ce que** le procédé comprend:

(c) l'interruption du forage de la seconde section de puits (12), l'actionnement du moyen de hissage (16) pour tirer le câble et ainsi l'ensemble vers le haut à travers le puits jusqu'à ce que le moyen de connexion de câble (15) soit positionné à l'intérieur du lubrificateur (17) ;

(d) le déplacement du moyen de traction de câble (20) vers le haut le long du câble à l'intérieur du lubrificateur (17) jusqu'à une position en dessous du moyen de connexion de câble (15) ;

(e) la fermeture de la vanne de surface (18) pour sceller le puits, la déconnexion lubrificateur (17) et la déconnexion du moyen de connexion de câble (15) ;

(f) la disposition d'un tubage perdu expansible (19) de manière concentrique autour du câble supporté sur le moyen de traction (20) ;

(g) la reconnexion du moyen de connexion de câble (15) et la reconnexion du lubrificateur (17) ;

(h) l'ouverture de la vanne de surface (18) et le déplacement du moyen de traction de câble (20) vers le bas le long du câble de telle sorte que le tubage perdu expansible (19) supporté sur le moyen de traction de câble passe à travers la vanne de surface (18) et dans le puits jusqu'à une position dans laquelle la partie supérieure du tubage perdu expansible (19) chevauche la partie inférieure du tubage tubulaire (11) et la partie inférieure du tubage perdu expansible s'étend dans l'orifice ouvert de la seconde section de puits (12) ;

(i) l'actionnement du moyen d'expansion (2) de l'ensemble pour dilater la partie supérieure du tubage perdu expansible (19) à l'intérieur de la partie inférieure du tubage tubulaire (11) afin de former une connexion scellée entre eux et pour dilater la partie inférieure du tubage perdu expansible afin de dilater le tubage tubulaire dans la seconde section de puits ;

(j) en option, le recommencement du forage de la seconde section de puits et la répétition des étapes (b) à (i).

5. Appareil de forage et de tubage d'un puits, l'appareil

comprenant un ensemble de forage électrique contrôlé à distance suspendu depuis un câble (1) dans lequel est intégré au moins un câble électrique et/ou un conducteur électrique segmenté pour transmettre de l'électricité ou des signaux électriques depuis la surface jusqu'à l'ensemble, l'ensemble comprenant un moyen d'expansion (2) et un trépan à commande électrique (6), **caractérisé en ce que** le câble est doté d'un moyen de traction de câble (20) mobile le long du câble pour amener un tubage perdu expansible (19) depuis la surface jusqu'à l'ensemble.

6. Appareil selon la revendication 5, dans lequel l'ensemble de forage comprend un boîtier allongé, le boîtier comprenant (a) des moyens de connexion pour connecter l'ensemble à un câble de suspension, (b) un moteur électrique, (c) un moyen de commande pour faire tourner un trépan.

7. Appareil selon la revendication 6, dans lequel le moyen de commande pour faire tourner le trépan commande également un aléteur.

8. Appareil selon l'une des revendications 6 ou 7, comprenant en outre un moyen de direction à commande électrique capable de régler la trajectoire de la section de puits lorsque celui-ci est en cours de forage.

9. Appareil selon la revendication 6, comprenant en outre un moyen de traction électrique pour déplacer l'ensemble de forage à l'intérieur du puits.

10. Appareil selon la revendication 6, comprenant en outre une lame radialement extensible pour couper une section de tubage du tubage perdu expansible.

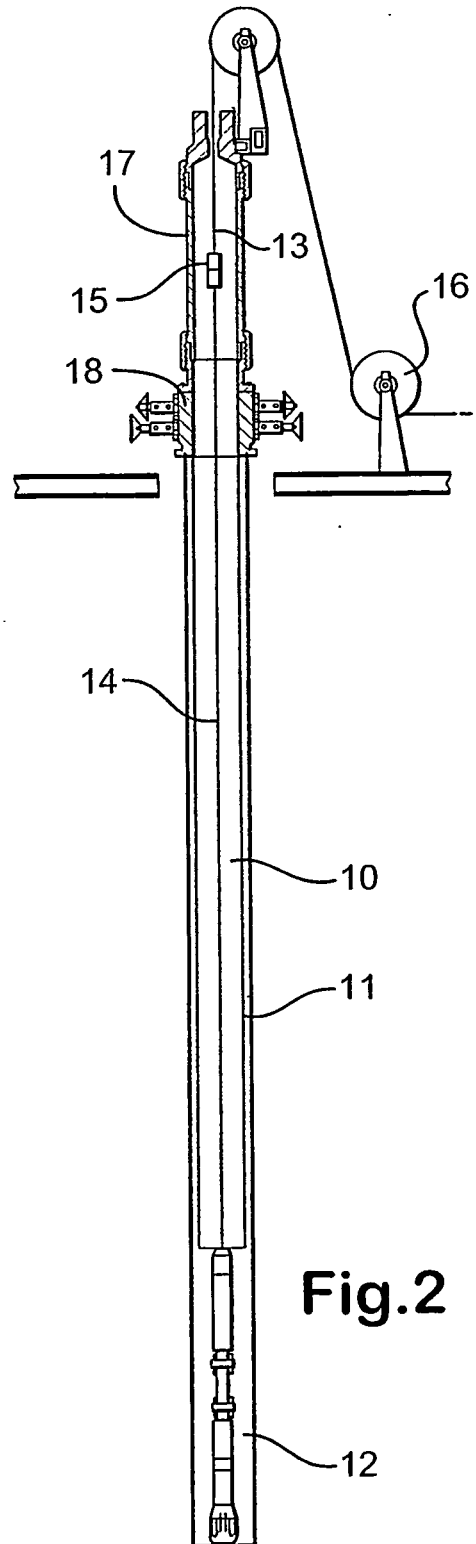
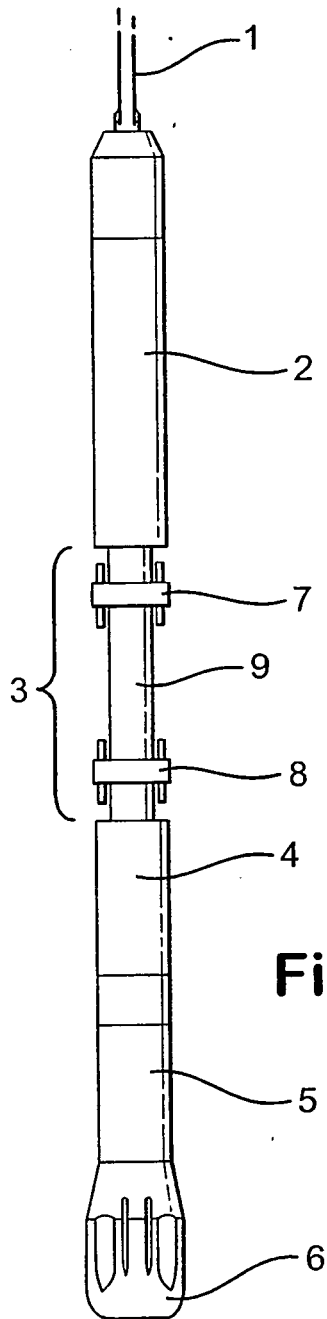

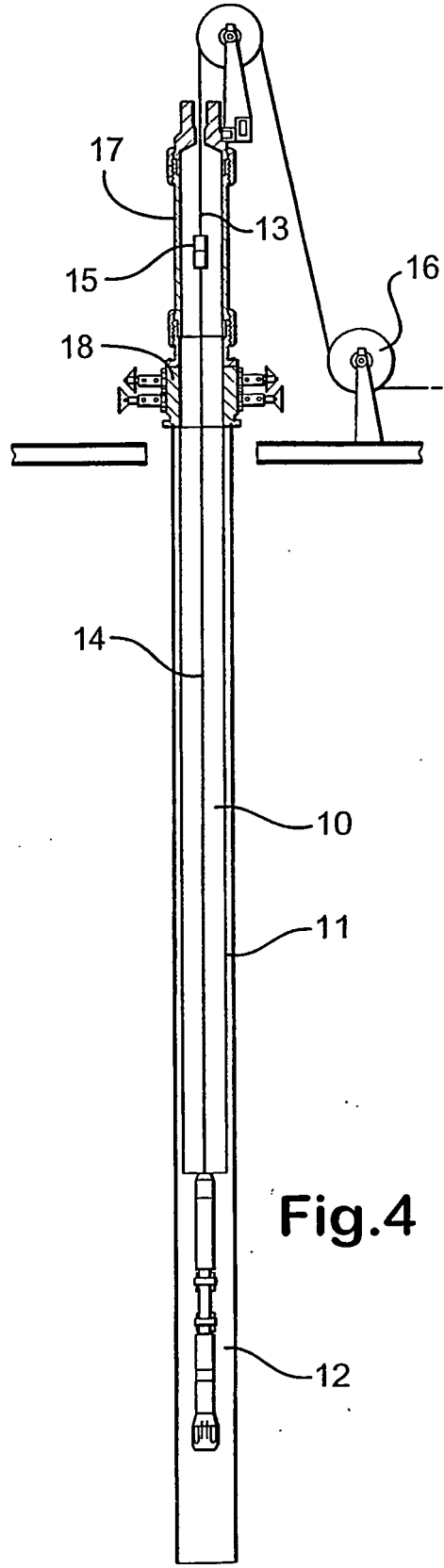
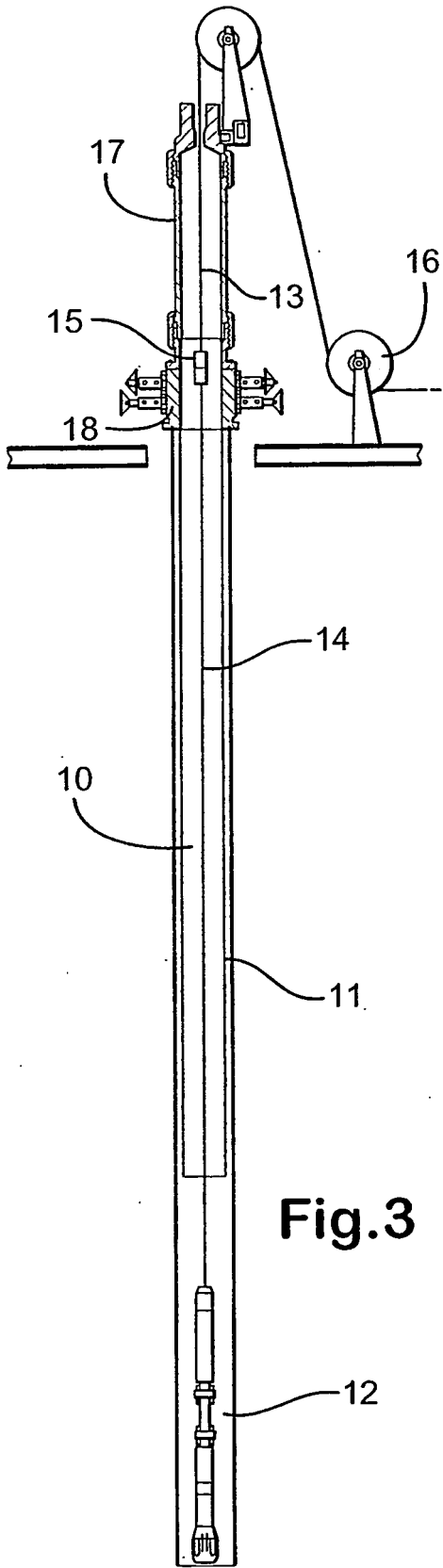

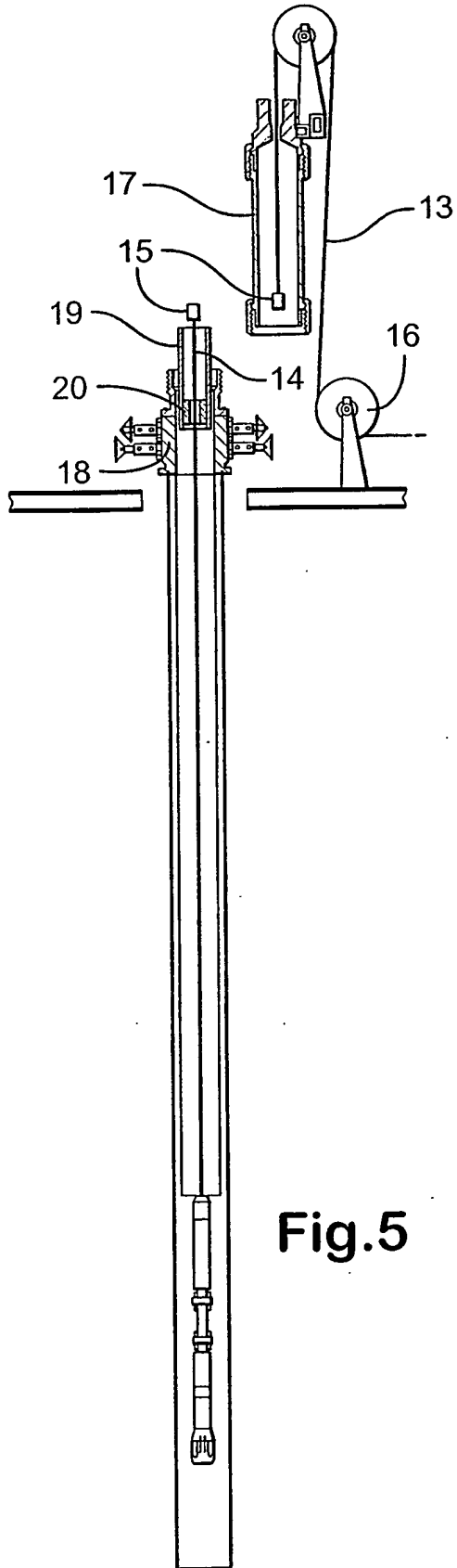

Fig.5

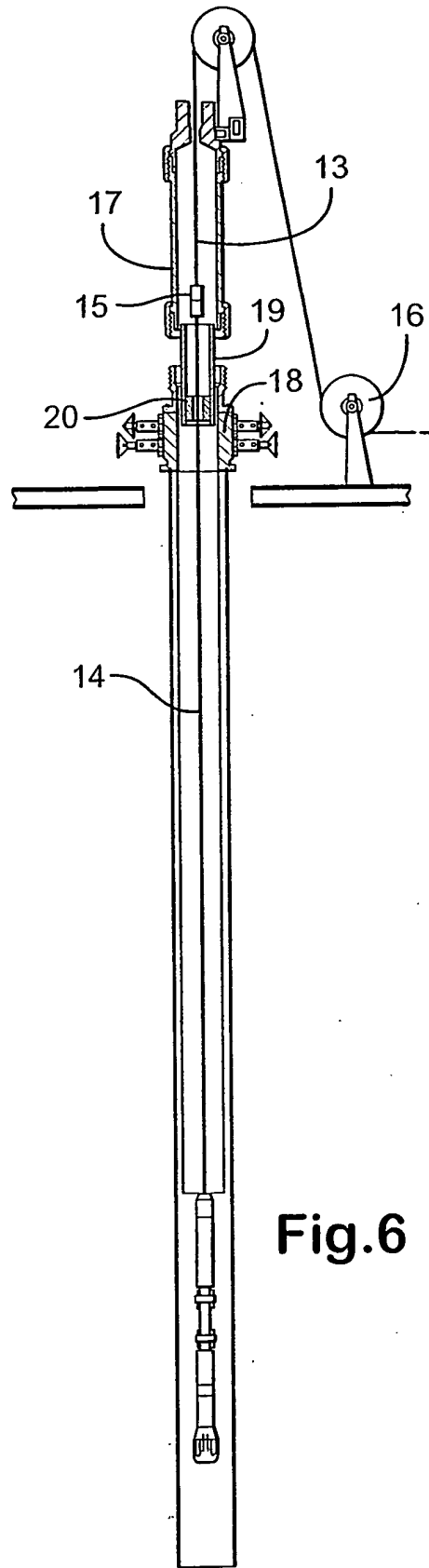

Fig.6

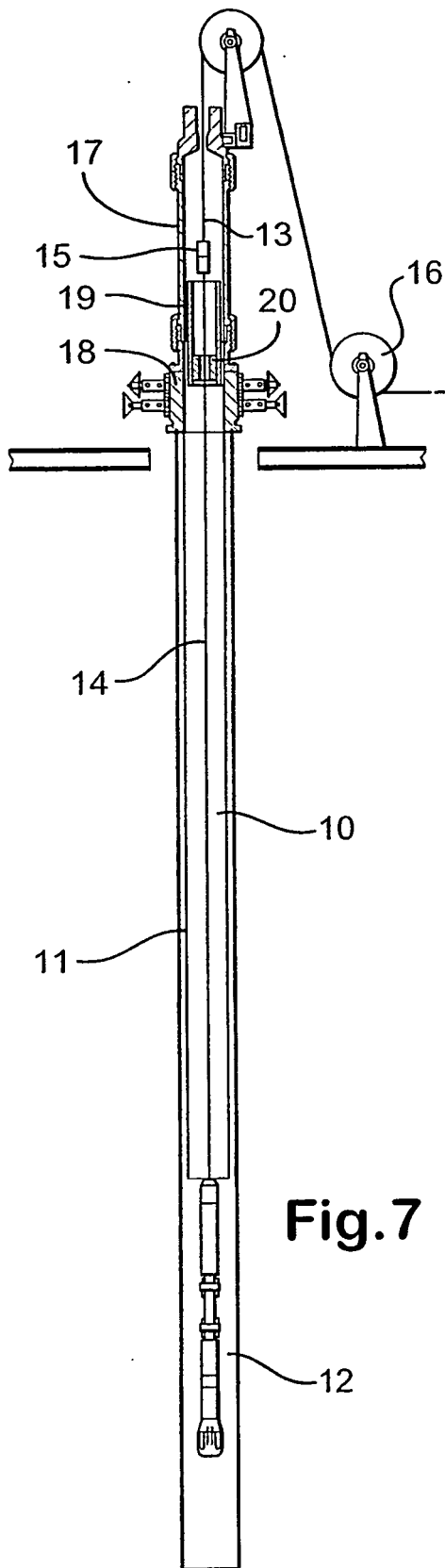

Fig. 7

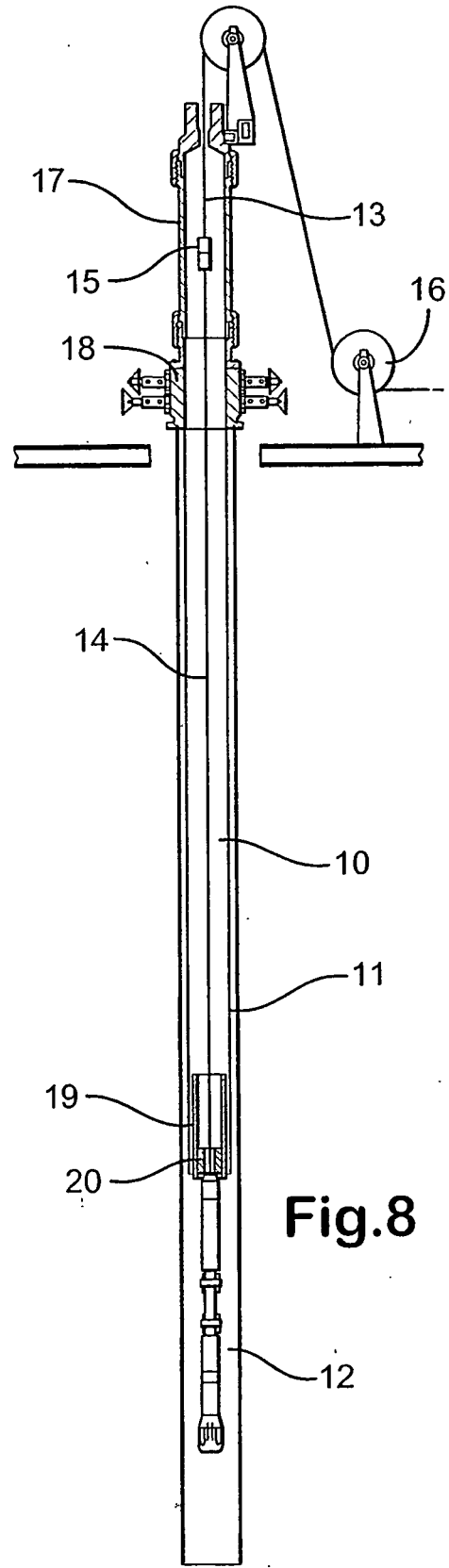

Fig. 8

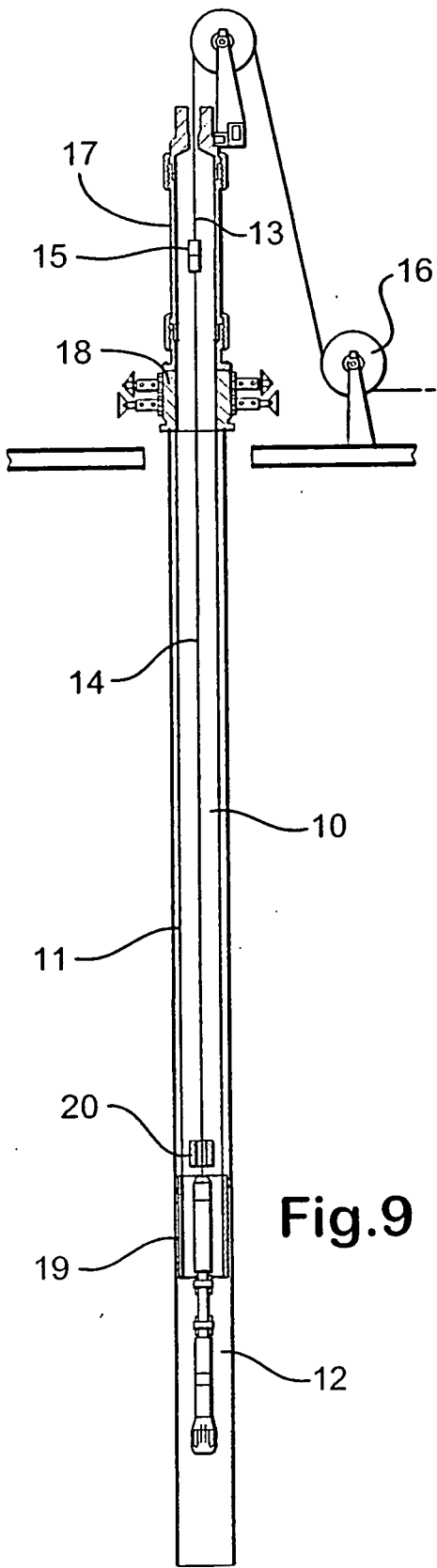

Fig.9

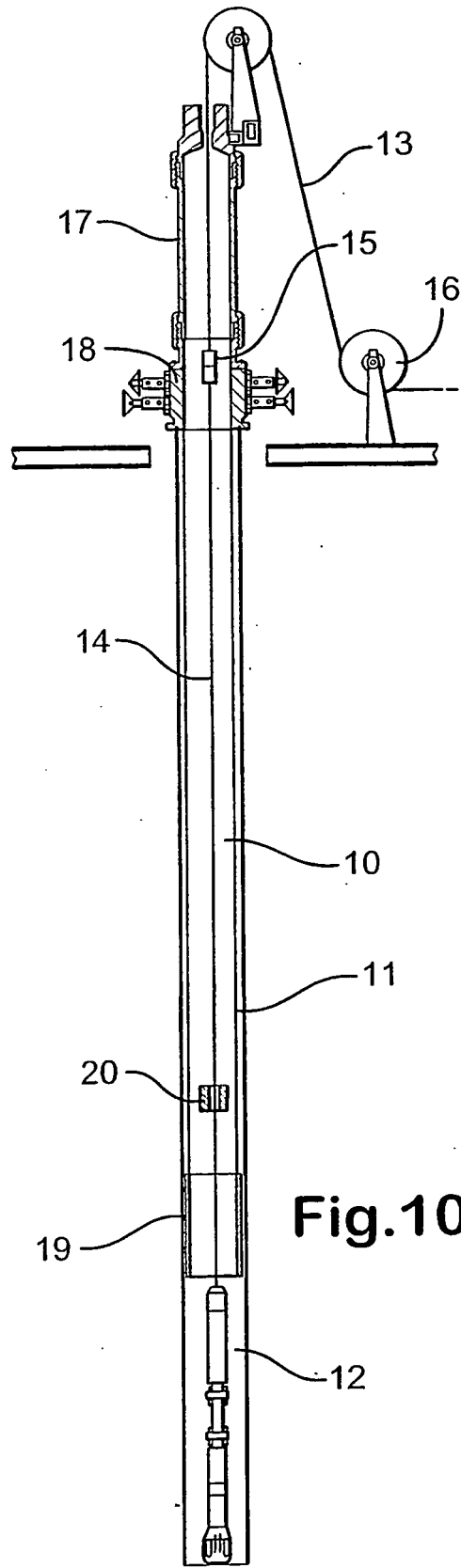

Fig.10

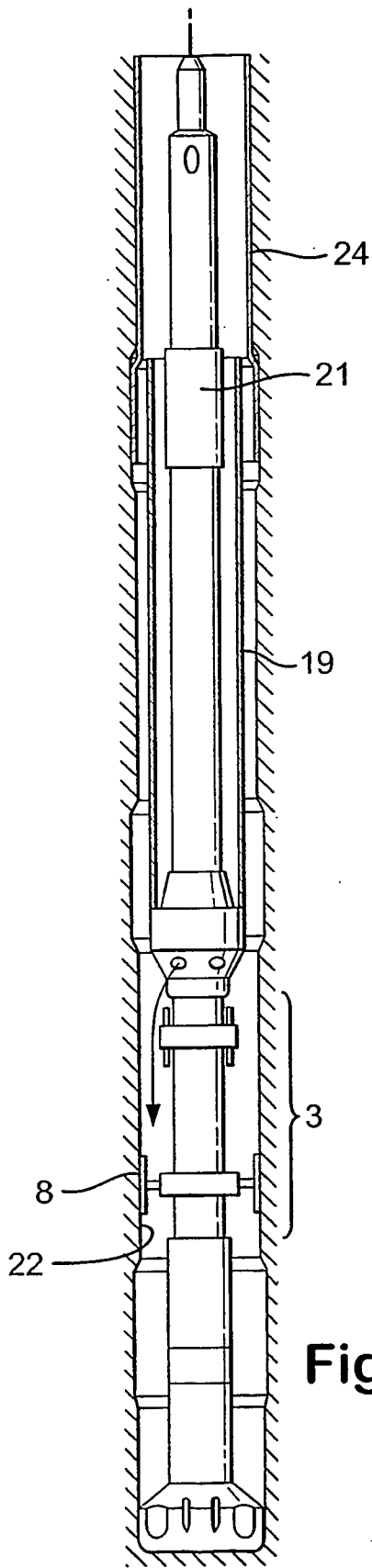

Fig.11

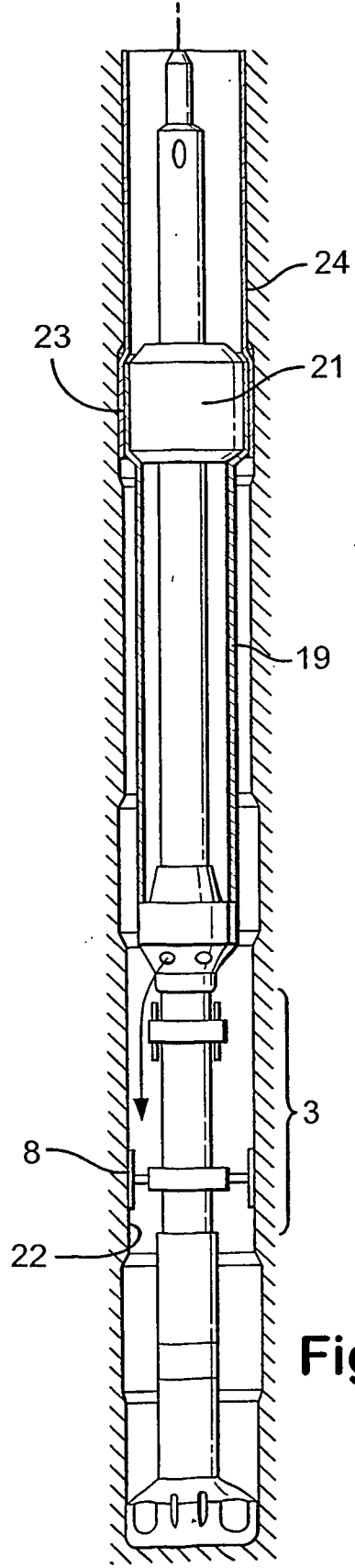
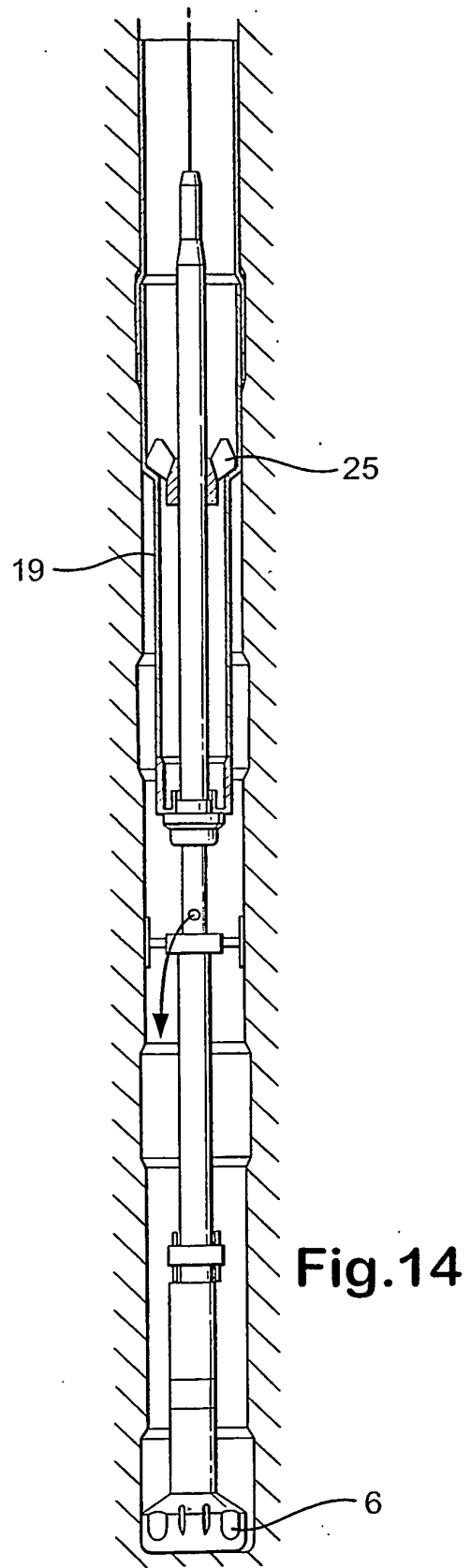
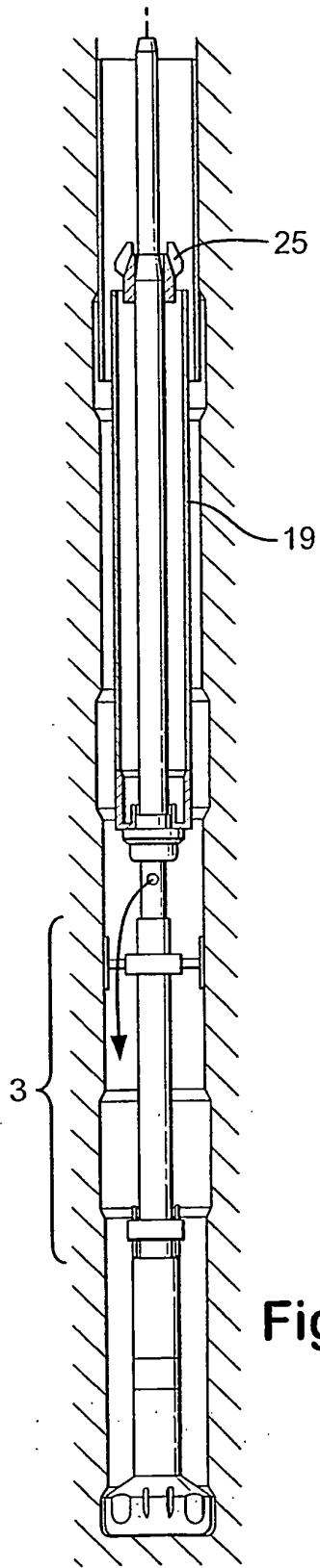

Fig.12



REFERENCES CITED IN THE DESCRIPTION

This list of references cited by the applicant is for the reader's convenience only. It does not form part of the European patent document. Even though great care has been taken in compiling the references, errors or omissions cannot be excluded and the EPO disclaims all liability in this regard.

Patent documents cited in the description

- US 20030034177 A [0006]
- US 20010052427 A [0007]