



(11) **EP 1 714 583 B1**

(12) **EUROPEAN PATENT SPECIFICATION**

(45) Date of publication and mention of the grant of the patent:
16.07.2008 Bulletin 2008/29

(51) Int Cl.:
A47C 7/02^(2006.01)

(21) Application number: **06252089.5**

(22) Date of filing: **18.04.2006**

(54) **A seat with an inflatable seat portion**

Sitz mit einem aufblasbaren Sitzteil

Siège avec assise gonflable

(84) Designated Contracting States:
AT BE BG CH CY CZ DE DK EE ES FI FR GB GR HU IE IS IT LI LT LU LV MC NL PL PT RO SE SI SK TR

(30) Priority: **22.04.2005 GB 0508207**

(43) Date of publication of application:
25.10.2006 Bulletin 2006/43

(73) Proprietor: **Seating Design & Development Limited Brentwood, Essex CM15 8AP (GB)**

(72) Inventors:
• **Marshall, Neal Solihull, West Midlands B91 1JX (GB)**

• **Moule, Terry Glyn deceased (GB)**

(74) Representative: **Jones, Graham Henry Graham Jones & Company Blackheath 77 Beaconsfield Road London SE3 7LG (GB)**

(56) References cited:
EP-A- 1 396 246 WO-A-00/03623
WO-A-95/33396 DE-A1- 10 353 596
US-A- 3 296 635 US-A- 6 086 151
US-A1- 2004 195 898

EP 1 714 583 B1

Note: Within nine months of the publication of the mention of the grant of the European patent in the European Patent Bulletin, any person may give notice to the European Patent Office of opposition to that patent, in accordance with the Implementing Regulations. Notice of opposition shall not be deemed to have been filed until the opposition fee has been paid. (Art. 99(1) European Patent Convention).

Description

[0001] This invention relates to a seat, and more especially, this invention relates to a seat with an inflatable seat portion.

[0002] There are many types of seats comprising a seat portion and a back rest portion, The seats are often such that the seat portion is not comfortable to sit on and does not give adequate support to the posterior of a person sitting on the seat portion. The seat portion may, for example, restrict the positioning of the person's pelvic girdle and it may apply undue pressure to the person's ischial tuberosities, in addition to restricting local blood flow and pinching local nerves in the region of the person's posterior.

[0003] In International Publication No. WO 00/03623 there is disclosed a seat comprising a seat portion and a backrest portion. The seat portion comprises a main portion and a plurality of insert portions. One of the insert portions is rectangular and is positioned so as to be underneath the posterior of a person sitting on the insert portion. Two of the insert portions are rectangular and are positioned so as to be underneath the thighs of the person sitting on the seat portion. The insert portions are able to be inflated and deflated. WO 00/03623 is concerned with an electronic control system for controlling the inflation and deflation of the insert portions.

[0004] In International Publication No. WO 2005/002914 there is disclosed a seat comprising a seat portion and a backrest portion, the seat portion comprising a main portion and an insert portion, the insert portion being such that it fits into a complementarity shaped recess in the main portion. The insert portion comprises a pair of pads which are positioned so as to be underneath the cheeks of the posterior of a person sitting on the insert portion. The insert portion also comprises a pair of legs which are positioned so as to be underneath the thighs of the person sitting on the seat portion. The insert portion and the main portion are made of a foam material. The foam material of the insert portion may be of a different density to the foam material of the main portion.

[0005] It is an aim of the present invention to retain the advantageous shape of the seat portion as set out in WO 2005/002914, whilst at the same time providing a completely different construction for the seat portion, and which seat construction gives varying control over the hardness/softness of the seat portion.

[0006] Accordingly, the present invention provides a seat comprising a seat portion and a backrest portion, the seat portion comprising a seat main portion and a seat insert portion, characterised in that the seat insert portion is softer than the seat main portion, the seat insert portion is positioned in a complementarily shaped recess in the seat main portion, the seat insert portion comprises a pair of pads which are positioned so as to be underneath the cheeks of the posterior of a person sitting on the seat portion with their legs extending over a front of the seat portion and not straddling the seat portion, the seat insert

portion comprises a pair of legs which are positioned so as to be underneath the thighs of the person sitting on the seat portion with their legs extending over a front of the seat portion and not straddling the seat portion, a part of the seat main portion is positioned between the pair of legs of the seat insert portion, the pair of pads of the seat insert portion and the pair of legs of the seat insert portion provide a continuous uninterrupted area which is softer than the seat main portion, and the seat insert portion is an inflatable seat insert portion which is able to be inflated and deflated by a user for maximum personal comfort of the user.

[0007] The ability of each user of a seat to control the amount of inflation and deflation in the seat insert portion means that each user of a seat is able to adjust the seat to their own requirements for their own maximum personal comfort.

[0008] The seat insert portion may be inflatable by a gas or a hydraulic liquid. The gas is preferably air.

[0009] The seat insert portion may be formed to have one single inflatable compartment. Alternatively, the seat insert portion may be formed to have a plurality of separate inflatable compartments.

[0010] The pads and the legs preferably have curved faces which engage complementarily curved faces in the recess. Other shapes may however be employed.

[0011] Preferably, the seat insert portion is softer than the seat main portion. If desired however the seat insert portion may be harder than the seat main portion. Advantageously, the degree of hardness of the seat insert portion can be controlled by each user to their own personal requirements.

[0012] The seat may include control means for inflating and deflating the seat insert portion.

[0013] The control means may include a manually-operated hand pump for pumping an inflating medium into the seat insert portion for inflating the seat insert portion, and an outlet valve to removing the inflating medium from the seat insert portion for deflating the seat insert portion. In the case of air, the removed inflating medium can be exhausted to the environment. In the case of a gas that needs saving or a hydraulic inflating medium, then the inflating medium can be taken from the seat portion and saved in a reservoir chamber. As an alternative to the use of a manually-operated hand pump, an electrically operated pump may be employed.

[0014] The seat may be one in which the seat main portion is an inflatable seat main portion.

[0015] The seat main portion may be inflatable by a gas or a hydraulic liquid. The gas is preferably air.

[0016] The seat main portion may be formed to have one single inflatable compartment. Alternatively, the seat main portion may be formed to have a plurality of separate inflatable compartments.

[0017] The seat main portion may include control means for inflating and deflating the seat main portion.

[0018] The seat may be one in which the control means includes a manually-operated hand pump for pumping

the inflating medium into the seat main portion for inflating the seat main portion, and an outlet valve for removing the inflating medium from the seat main portion for deflating the seat main portion.

[0019] Alternatively, if desired, the seat main portion may be made of a foam material.

[0020] The seat portion may include a heating element.

[0021] The seat may be one in which the backrest portion comprises a backrest main portion and a backrest insert portion, and the backrest insert portion being an inflatable backrest insert portion which is able to be inflated and deflated by a user for maximum personal comfort of the user. Thus, for example the inflatable backrest insert portion may provide optimum lumbar support for the back of the person irrespective of the height and weight of the person.

[0022] The backrest insert portion may be inflatable by a gas or a hydraulic liquid. The gas is preferably air. The backrest insert portion may be formed to have one single inflatable compartment. Alternatively, the backrest insert portion may be formed to have a plurality of separate inflatable compartments.

[0023] The backrest insert portion may include control means for inflating and deflating the backrest insert portion. The control means may include manually-operated hand pump for pumping the inflating medium into the backrest insert portion for inflating the backrest insert portion, and an outlet valve for removing the inflating medium from the backrest insert portion for deflating the backrest insert portion. If desired, the control means may include an electrically-operated pump instead of the manually-operated hand pump.

[0024] The seat may be one in which the backrest insert portion is such that it is softer than the backrest main portion. Alternatively, the backrest insert portion may be such that it is harder than the backrest main portion.

[0025] The backrest main portion may be an inflatable backrest main portion.

[0026] The backrest main portion may be inflatable by a gas or a hydraulic liquid. The gas is preferably air.

[0027] The backrest main portion may be formed to have one single inflatable compartment. Alternatively, the backrest main portion may be formed to have a plurality of separate inflatable compartments.

[0028] The backrest main portion may include control means for inflating and deflating the backrest main portion. The control means may include a manually-operated hand pump for pumping an inflating medium into the backrest main portion for inflating the backrest main portion, and an outlet valve for removing the inflating medium from the backrest main portion for deflating the backrest main portion. Alternatively, if desired, an electrically-operated pump may be employed instead of the manually-operated hand pump.

[0029] Alternatively, if desired, the backrest main portion may be made of a foam material.

[0030] Where the seat has more than one inflatable/deflatable seat part, then the same type of control means

will usually be employed for all of the inflatable/deflatable seat parts. One pump, for example one manually-operated hand pump or one electrically-operated pump may be employed for inflating parts of the seat, with the inflating medium being able to be directed to and removed from different parts of the seats by selection of appropriate valve means from a control panel.

[0031] The seat may include a headrest portion.

[0032] The seat may be any suitable and appropriate seat. Thus, for example, the seat may be a vehicle seat for a motor vehicle, an aircraft seat for an aircraft, a boat seat for a boat, a military seat for a military vehicle, a train seat for a train, a hovercraft for a hovercraft, a domestic seat for domestic use, an office seat for office use, or an industrial seat for use in industrial premises.

[0033] Where the seat is a vehicle seat for a motor vehicle, then the motor vehicle may be any suitable and appropriate motor vehicle including a car, van, bus, coach or lorry. Where the seat is a seat for a boat or a hovercraft, then the seat may be especially advantageous for ferries where passengers are generally required to sit together in their seats for the duration of their journey. Where the seat is a domestic seat, then the domestic seat may be a chair, armchair or settee.

[0034] Embodiments of the invention will now be described solely by way of example and with reference to the accompanying drawings in which:

Figure 1 is an exploded view of a seat portion of a seat; and

Figure 2 is an exploded view of a backrest portion of a seat.

[0035] Referring to Figure 1, there is shown a seat portion 2 of a seat. The entire seat is not shown but the seat comprises the seat portion 2 and a backrest portion.

[0036] The seat portion 2 comprises a seat main portion 4 and a seat insert portion 6. The seat insert portion 6 is such that it fits into a complementarily shaped recess 8 in the seat main portion 4. The seat insert portion 6 comprises a pair of pads 10, 12 which are positioned so as to be underneath the cheeks of the posterior of a person sitting on the seat portion 2 with their legs extending over the front of the seat portion 2 and not straddling the seat portion 2. The seat insert portion 6 also comprises a pair of legs 14, 16 which are positioned so as to be underneath the thighs of the person sitting on the seat portion 2 with their legs extending over a front of the seat portion 2 and not straddling the seat portion 2. A part 17 of the seat main portion 4 is positioned between the pair of legs 14, 16 of the seat insert portion 6. The pair of pads 10, 12 of the seat insert portion 6 and the pair of legs 14, 16 of the seat insert portion 6 provide a continuous uninterrupted area which is softer than the main seat portion 4.

[0037] The seat insert portion 6 is such that it is an inflatable seat insert portion 6. The seat insert portion 6 is such that it is able to be inflated and deflated by a user

for maximum personal comfort of the user. The seat insert portion 6 is able to be inflated by gas in the form of air. The seat insert portion 6 is formed to have one single inflatable compartment. The pads 10, 12 and the legs 14, 16 have curved faces which engage complementarily curved faces 18 in the recess 8. When inflated, the seat insert portion 6 will usually be softer than the seat main portion 4.

[0038] The seat insert portion 6 includes control means 20 for inflating and deflating the seat insert portion 6. The control means 20 comprises a manually-operated hand pump 22 which is connected to the body of the seat insert portion 6 by a tube 24. Repeated squeezing of the hand pump 22 is effected to inflate the seat insert portion 6. If the seat insert portion 6 is inflated too much, then air can be released via an outlet valve (not shown).

[0039] The seat main portion 4 is an inflatable seat main portion 4. The seat main portion 4 is also inflated by gas in the form of air. The seat main portion 4 is formed to have one single inflatable compartment. The seat main portion 4 is inflated by control means 26 which is basically the same as the control means 20 and which thus comprises a hand pump 28, a tube 30 and an outlet valve (not shown). When inflated, the seat main portion 4 will usually be inflated to be harder than the seat insert portion 6, but the reverse arrangement may be employed if desired. When the seat main portion 4 and the seat insert portion 6 are inflated, then relative movement between the two portions 4, 6 may occur if a person sitting on the seat portion 6 wishes to apply, for example, more weight on one side of the seat insert portion 6 than the other side of the seat insert portion 6. This relative movement may occur with all seat portions of the seat of the present invention.

[0040] Referring now to Figure 2, there is shown a backrest portion 32 of a seat. The backrest portion 32 may be used with the seat portion 2, or it may be used with another type of seat portion.

[0041] The backrest portion 32 comprises a backrest main portion 34 and a backrest insert portion 36. The backrest insert portion 36 is an inflatable backrest insert portion which is able to be inflated and deflated by a user for maximum personal comfort of the user. Thus, for example, the backrest insert portion 36 can be inflated to provide optimum lumbar support for the back of the user, irrespective of the height and weight of the user.

[0042] The backrest insert portion is inflatable by gas in the form of air. The backrest insert portion is formed to have one single inflatable compartment.

[0043] The backrest insert portion includes control means 38 for inflating and deflating the backrest insert portion 36. The control means 38 comprises a manually-operated hand pump 40 which is connected to the remainder of the backrest insert portion 36 by a tube 32. Control means 36 also includes a control valve (not shown) for removing air from the backrest insert portion 36 if it has been over inflated by operation of the hand pump 40. The backrest insert portion 36 has a curved

face 44 which fits a complementary curved face 46 of a recess 48 in the backrest main portion 34.

[0044] The backrest main portion 34 is an inflatable backrest main portion. The backrest main portion 34 is inflatable by gas in the form of air. The backrest main portion 34 is formed to have one single inflatable compartment.

[0045] The backrest main portion 34 has control means 50 for enabling the backrest main portion 34 to be inflated. The control means 50 comprises a manually-operated hand pump 52 which is connected to the main body of the backrest main portion 34 by a tube 54. An outlet valve (not shown) is provided for removing air from the backrest main portion 34 if this should be desired.

[0046] It is to be appreciated that the embodiments of the invention described above with reference to the accompanying drawings have been given by way of example only and that modifications may be effected within the scope of the appended claims. Thus, for example, the seat main portion 4 may be made of a foam material instead of being inflatable. If the backrest portion 32 is used with the seat portion 2, then the entire backrest portion 32 may be made of a foam material, or just the backrest main portion 34 or just the backrest insert portion 36 may be made of a foam material. The backrest portion 32 may be provided with a headrest portion (not shown). Gases other than air and also hydraulic fluids may be employed to inflate the chosen inflatable parts of the seat. A single pump and an appropriate control panel may be employed to inflate different parts of the seat. The pump may be an electrically-operated pump rather than a hand-operated manual pump if desired.

35 Claims

1. A seat comprising a seat portion (2) and a backrest portion, the seat portion (2) comprising a seat main portion (4) and a seat insert portion (6), **characterised in that** the seat insert portion (6) is softer than the seat main portion (4), the seat insert portion (6) is positioned in a complementarily shaped recess (8) in the seat main portion (4), the seat insert portion (6) comprises a pair of pads (10, 12) which are positioned so as to be underneath the cheeks of the posterior of a person sitting on the seat portion (2), the seat insert portion (6) comprises a pair of legs (14, 16) which are positioned so as to be underneath the thighs of the person sitting on the seat portion, a part (17) of the seat main portion (4) is positioned between the pair of legs (14, 16) of the seat insert portion (6), the pair of pads (10, 12) of the seat insert portion (6) and the pair of legs (14, 16) of the seat insert portion (6) provide a continuous uninterrupted area which is softer than the seat main portion (4), and the seat insert portion (6) is an Inflatable seat insert portion (6) which is able to be inflated and deflated by a user for maximum personal comfort of

- the user.
2. A seat according to claim 1 in which the seat insert portion (6) is inflatable by gas or a hydraulic liquid.
 3. A seat according to claim 1 or claim 2 in which the seat insert portion (6) is formed to have one single inflatable compartment or a plurality of separate inflatable compartments.
 4. A seat according to any one of the preceding claims in which the pads (10, 12) and the legs (14, 16) have curved faces which engage complementarily curved faces in the recess.
 5. A seat according to any one of the preceding claims and including control means for inflating and deflating the seat insert portion.
 6. A seat according to any one of the preceding claims in which the seat main portion (4) is an inflatable seat main portion (4).
 7. A seat according to claim 6 in which the seat main portion (4) is Inflatable by gas or a hydraulic liquid.
 8. A seat according to claim 6 or claim 7 in which the seat main portion (4) is formed to have one single inflatable compartment or a plurality of separate inflatable compartments.
 9. A seat according to any one of claims 6 - 8 and including control means for inflating and deflating the seat main portion (4).
 10. A seat according to any one of claims 1 - 5 in which the seat main portion (4) is made of a foam material.
 11. A seat according to any one of the preceding claims in which the backrest portion comprises a backrest main portion and a backrest insert portion, and the backrest insert portion being an inflatable backrest insert portion which is able to be inflated and deflated by a user for maximum personal comfort of the user.
 12. A seat according to claim 11 in which the backrest insert portion is inflatable by a gas or a hydraulic liquid.
 13. A seat according to claim 11 or claim 12 in which the backrest insert portion is formed to have one single inflatable compartment or a plurality of separate inflatable compartments.
 14. A seat according to any one of claims 11 - 13 and including control means for inflating and deflating the backrest insert portion.
 15. A seat according to any one of claims 11 - 14 in which the backrest insert portion is such that it is softer than the backrest main portion.
 16. A seat according to any one of claims 11 - 15 in which the backrest main portion is an inflatable backrest main portion.
 17. A seat according to claim 16 in which the backrest main portion is inflatable by a gas or a hydraulic liquid.
 18. A seat according to claim 16 or claim 17 in which the backrest main portion is formed to have one single inflatable compartment or a plurality of separate inflatable compartments.
 19. A seat according to any one of claims 15 - 18 and including control means for inflating and deflating the backrest main portion.
 20. A seat according to claim 11 in which the backrest main portion is made of a foam material.
 21. A seat according to any one of claims 11 - 20 and including a headrest portion.

Patentansprüche

1. Ein Sitz mit einem Sitzbereich (2) und einem Lehnenbereich, wobei der Sitzbereich (2) einen Sitz-Hauptbereich (4) und einen Sitzeinsatzbereich (6) hat, **gekennzeichnet dadurch, dass** der Sitzeinsatzbereich (6) weicher ist als der Sitzhauptbereich (4), dass der Sitzeinsatzbereich (6) in einer komplementär geformten Vertiefung (8) in dem Hauptsitzbereich (4) angeordnet ist, der Sitzeinsatzbereich (6) ein Paar von Kissen (10, 12) aufweist, die so angeordnet sind, dass sie unter den Hinterbacken einer Person, die auf dem Sitzbereich (2) sitzt, sind, wobei der Sitzeinsatzbereich (6) in Paar von Beinen (14, 16) aufweist, die so angeordnet sind, dass sie unterhalb der Schenkel der Person, die auf dem Sitzbereich sitzt, sind, wobei ein Teil (17) des Sitzhauptbereiches (4) zwischen dem Paar von Beinen (14, 16) des Sitzeinsatzbereiches (6) angeordnet ist, wobei das Paar von Kissen (10, 12) des Sitzeinsatzbereiches (6) und das Paar von Beinen (14, 16) des Sitzeinsatzbereiches (6) eine kontinuierliche, ununterbrochene Fläche schaffen, die weicher ist als der Hauptsitzbereich (4) und der Sitzeinsatzbereich (6) ein aufblasbarer Sitzeinsatzbereich (6) ist, der durch einen Benutzer aufgeblasen und abgelassen werden kann, für die höchstmögliche persönliche Bequemlichkeit des Benutzers.
2. Ein Sitz nach Anspruch 1, in dem der Sitzeinsatzbe-

- reich (6) durch Gas oder eine hydraulische Flüssigkeit aufblasbar ist.
3. Ein Sitz nach Anspruch 1 oder 2, in dem der Sitzeinsatzbereich (6) so gebildet ist, dass er ein einzelnes aufblasbares Abteil oder eine Mehrzahl von getrennten aufblasbaren Abteilen hat. 5
 4. Ein Sitz nach irgendeinem der vorhergehenden Ansprüche, in dem die Kissen (10, 12) und die Beine (14, 16) gewölbte Seiten haben, die mit entsprechend gewölbten Seiten in der Vertiefung in Eingriff gelangen. 10
 5. Ein Sitz nach irgendeinem der vorhergehenden Ansprüche, und aufweisend Steuereinrichtungen zum Aufblasen und Ablassen des Sitzeinsatzbereiches. 15
 6. Ein Sitz nach irgendeinem der vorhergehenden Ansprüche, in dem der Sitzhauptbereich (4) ein aufblasbarer Sitzhauptbereich (4) ist. 20
 7. Ein Sitz nach Anspruch 6, in dem der Sitzhauptbereich (4) durch Gas oder eine hydraulische Flüssigkeit aufblasbar ist. 25
 8. Ein Sitz nach Anspruch 6 oder Anspruch 7, in dem der Sitzhauptbereich (4) so gebildet ist, dass er ein einzelnes aufblasbares Abteil oder eine Mehrzahl von getrennten aufblasbaren Abteilen hat. 30
 9. Ein Sitz nach irgendeinem der Ansprüche 6 - 8, und aufweisend Steuereinrichtungen zum Aufblasen und Ablassen des Sitzhauptbereiches (4). 35
 10. Ein Sitz nach irgendeinem der Ansprüche 1 - 5, in dem der Sitzhauptbereich (4) aus Schaumstoff hergestellt ist. 40
 11. Ein Sitz nach irgendeinem der vorhergehenden Ansprüche, in dem der Lehnbereich einen Lehnhauptbereich und ein Lehneneinsatzbereich aufweist, und der Lehneneinsatzbereich ein aufblasbarer Lehneneinsatzbereich ist, der durch einen Benutzer aufgeblasen und abgelassen werden kann, für die maximale persönliche Bequemlichkeit des Benutzers. 45
 12. Ein Sitz nach Anspruch 11, in dem der Lehneneinsatzbereich durch ein Gas oder eine hydraulische Flüssigkeit aufblasbar ist. 50
 13. Ein Sitz nach Anspruch 11 oder Anspruch 12, in dem der Lehneneinsatzbereich so gebildet ist, dass er ein einzelnes aufblasbares Abteil oder eine Mehrzahl von getrennten aufblasbaren Abteilen hat. 55
 14. Ein Sitz nach irgendeinem der Ansprüche 11 - 13, und aufweisend Steuereinrichtungen zum Aufblasen und Ablassen des Lehneneinsatzbereiches.
 15. Ein Sitz nach irgendeinem der Ansprüche 11 - 14, in dem der Lehneneinsatzbereich derart ist, dass er weicher ist als der Lehnhauptbereich.
 16. Ein Sitz nach irgendeinem der Ansprüche 11 - 15, in dem der Lehnhauptbereich ein aufblasbarer Lehnhauptbereich ist.
 17. Ein Sitz nach Anspruch 16, in dem der Lehnhauptbereich durch ein Gas oder eine hydraulische Flüssigkeit aufblasbar ist.
 18. Ein Sitz nach Anspruch 16 oder Anspruch 17, in dem der Lehnhauptbereich so gebildet ist, dass er ein einzelnes aufblasbares Abteil oder eine Mehrzahl von getrennten aufblasbaren Abteilen hat.
 19. Ein Sitz nach irgendeinem der Ansprüche 15-18, und aufweisend Steuereinrichtungen zum Aufblasen und Ablassen des Lehnhauptbereiches.
 20. Ein Sitz nach Anspruch 11, in dem der Lehnhauptbereich aus Schaumstoff hergestellt ist.
 21. Ein Sitz nach irgendeinem der Ansprüche 11-20, aufweisend einen Kopfstützenbereich.

Revendications

1. siège comportant une partie d'assise (2) et une partie de dossier, la partie d'assise (2) comportant une partie principale d'assise (4) et une partie formant pièce rapportée d'assise (6), **caractérisé en ce que** la partie formant pièce rapportée d'assise (6) est plus molle que la partie principale d'assise (4), la partie formant pièce rapportée d'assise (6) est positionnée dans un évidement mis en forme de manière complémentaire (8) situé dans la partie principale d'assise (4), la partie formant pièce rapportée d'assise (6) comporte une paire de coussins (10, 12) qui sont positionnés de manière à être sous les fesses d'une personne assise sur la partie d'assise (2), la partie formant pièce rapportée d'assise (6) comportant une paire de jambes (14, 16) qui sont positionnées de manière à être sous les cuisses de la personne assise sur la partie d'assise (2), une partie (17) de la partie principale d'assise (4) est positionnée entre la paire de jambes (14, 16) de la partie formant pièce rapportée d'assise (6), la paire de coussins (10, 12) de la partie formant pièce rapportée d'assise (6) et la paire de jambes (14, 16) de la partie formant pièce rapportée d'assise (6) fournissent une surface ininterrompue continue qui est plus molle que la partie principale d'assise (4), et la partie formant pièce rap-

- portée d'assise (6) est une partie formant pièce rapportée d'assise gonflable (6) qui est susceptible d'être gonflée et dégonflée par un utilisateur pour un confort personnel maximum de l'utilisateur.
2. Sièges selon la revendication 1, dans lequel la partie formant pièce rapportée d'assise (6) peut être gonflée par un gaz ou un liquide hydraulique. 5
 3. Sièges selon la revendication 1 ou 2, dans lequel la partie formant pièce rapportée d'assise (6) est formée pour avoir un compartiment gonflable unique ou une pluralité de compartiments gonflables séparés. 10
 4. Sièges selon l'une quelconque des revendications précédentes, dans lequel les coussins (10, 12) et les jambes (14, 16) ont des faces incurvées qui viennent en prise avec des faces incurvées de manière complémentaire situées dans l'évidement. 15
 5. Sièges selon l'une quelconque des revendications précédentes, et comportant des moyens de commande pour gonfler et dégonfler la partie formant pièce rapportée d'assise. 20
 6. Sièges selon l'une quelconque des revendications précédentes, dans lequel la partie principale d'assise (4) est une partie principale d'assise gonflable (4). 25
 7. Sièges selon la revendication 6, dans lequel la partie principale d'assise (4) peut être gonflée par un gaz ou un liquide hydraulique. 30
 8. Sièges selon la revendication 6 ou 7, dans lequel la partie principale d'assise (4) est formée pour avoir un compartiment gonflable unique ou une pluralité de compartiments gonflables séparés. 35
 9. Sièges selon l'une quelconque des revendications 6 à 8, et comportant des moyens de commande pour gonfler et dégonfler la partie principale d'assise (4). 40
 10. Sièges selon l'une quelconque des revendications 1 à 5, dans lequel la partie principale d'assise (4) est constituée d'un matériau en mousse. 45
 11. Sièges selon l'une quelconque des revendications précédentes, dans lequel la partie de dossier comporte une partie principale de dossier et une partie formant pièce rapportée de dossier, la partie formant pièce rapportée de dossier étant une partie formant pièce rapportée de dossier gonflable qui est capable d'être gonflée et dégonflée par un utilisateur pour un confort personnel maximum de l'utilisateur. 50
 12. Sièges selon la revendication 11, dans lequel la partie formant pièce rapportée de dossier peut être gonflée par un gaz ou un liquide hydraulique. 55
 13. Sièges selon la revendication 11 ou 12, dans lequel la partie formant pièce rapportée de dossier est formée pour avoir un compartiment gonflable unique ou une pluralité de compartiments gonflables séparés.
 14. Sièges selon l'une quelconque des revendications 11 à 13, et comprenant des moyens de commande pour gonfler et dégonfler la partie formant pièce rapportée de dossier.
 15. Sièges selon l'une quelconque des revendications 11 à 14, dans lequel la partie formant pièce rapportée de dossier est telle qu'elle est plus molle que la partie principale de dossier.
 16. Sièges selon l'une quelconque des revendications 11 à 15, dans lequel la partie principale de dossier est une partie principale de dossier gonflable.
 17. Sièges selon la revendication 16, dans lequel la partie principale de dossier peut être gonflée par un gaz ou un liquide hydraulique.
 18. Sièges selon la revendication 16 ou 17, dans lequel la partie principale de dossier est formée pour avoir un composant gonflable unique ou une pluralité de composants gonflables séparés.
 19. Sièges selon l'une quelconque des revendications 15 à 18, et comprenant des moyens de commande pour gonfler et dégonfler la partie principale de dossier.
 20. Sièges selon la revendication 11, dans lequel la partie principale de dossier est constituée d'un matériau en mousse.
 21. Sièges selon l'une quelconque des revendications 11 à 20, et comprenant une partie d'appui-tête.

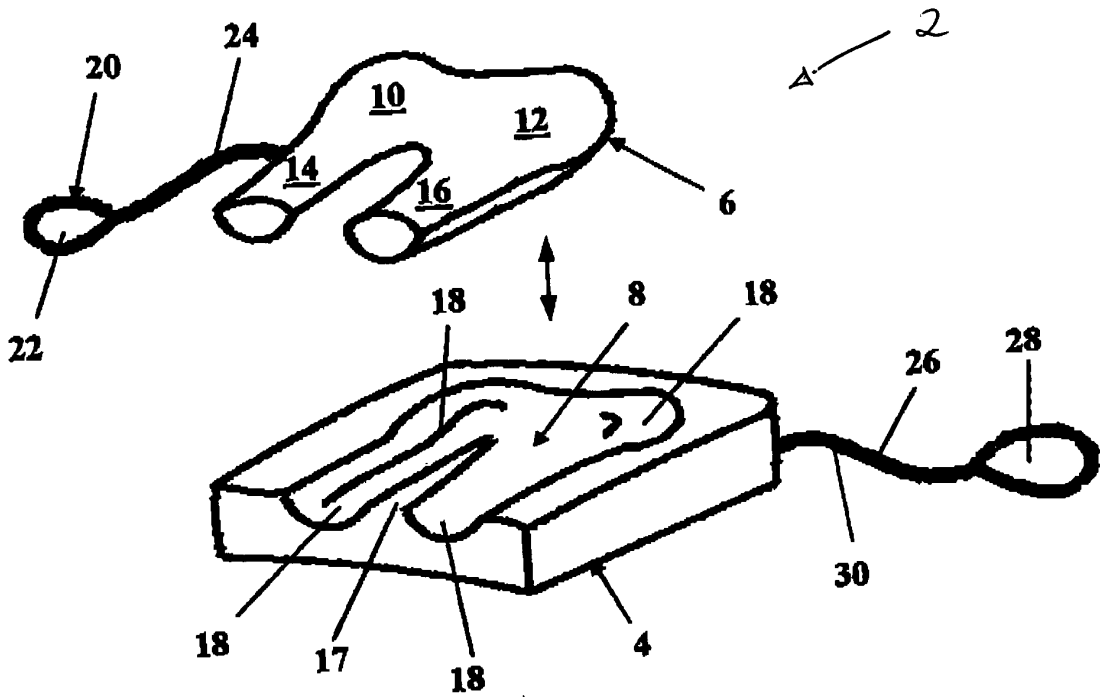

FIG 1

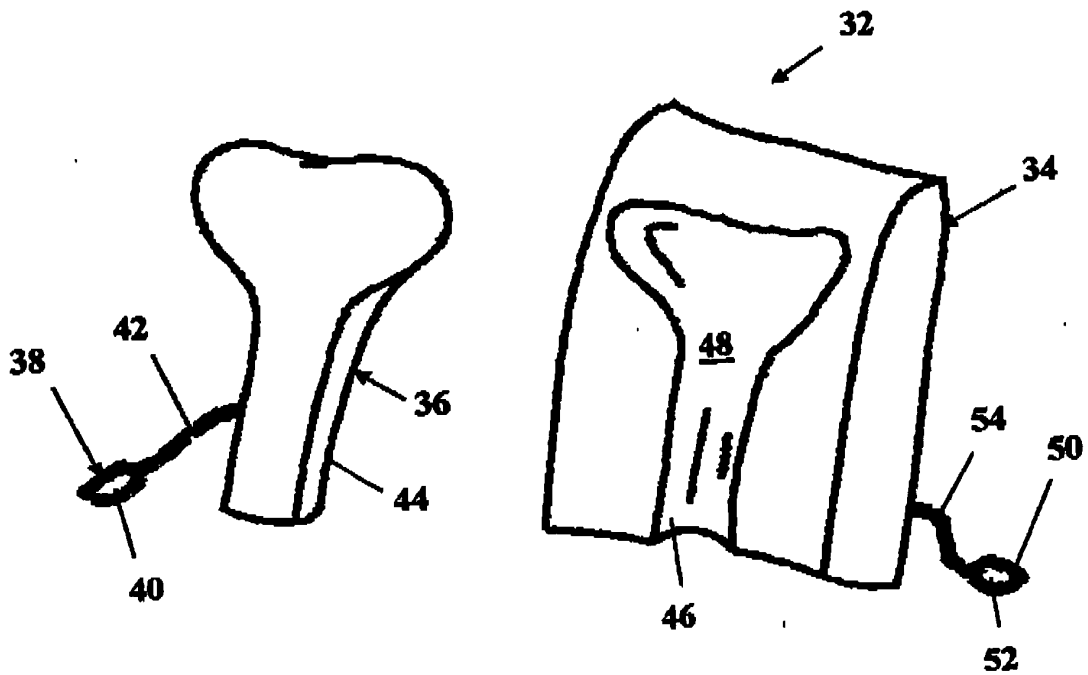

FIG 2

REFERENCES CITED IN THE DESCRIPTION

This list of references cited by the applicant is for the reader's convenience only. It does not form part of the European patent document. Even though great care has been taken in compiling the references, errors or omissions cannot be excluded and the EPO disclaims all liability in this regard.

Patent documents cited in the description

- WO 0003623 A [0003] [0003]
- WO 2005002914 A [0004] [0005]