



Europäisches Patentamt
 European Patent Office
 Office européen des brevets



(11) **EP 1 731 654 A1**

(12) **EUROPEAN PATENT APPLICATION**

(43) Date of publication:
13.12.2006 Bulletin 2006/50

(51) Int Cl.:
D06F 39/02 (2006.01)

(21) Application number: **06011370.1**

(22) Date of filing: **01.06.2006**

(84) Designated Contracting States:
**AT BE BG CH CY CZ DE DK EE ES FI FR GB GR
 HU IE IS IT LI LT LU LV MC NL PL PT RO SE SI
 SK TR**
 Designated Extension States:
AL BA HR MK YU

(71) Applicant: **LG Electronics Inc.
 Youngdungpo-Gu
 Seoul (KR)**

(72) Inventor: **Kang, Je Nam
 GwanAk-gu
 Seoul (KR)**

(30) Priority: **01.06.2005 KR 20050046717**

(74) Representative: **Vossius & Partner
 Siebertstrasse 4
 81675 München (DE)**

(54) **Detergent dispensing apparatus of washing machine**

(57) There is provided a detergent dispensing apparatus of a washing machine (100). The detergent dispensing apparatus includes a main body of the washing machine, a detergent cartridge (400) separately received

in the main body and storing a detergent therein, a detergent outlet formed on the detergent cartridge to define a detergent dispensing passage, and an opening/closing assembly for selectively opening and closing the detergent outlet.

【Figure 1】

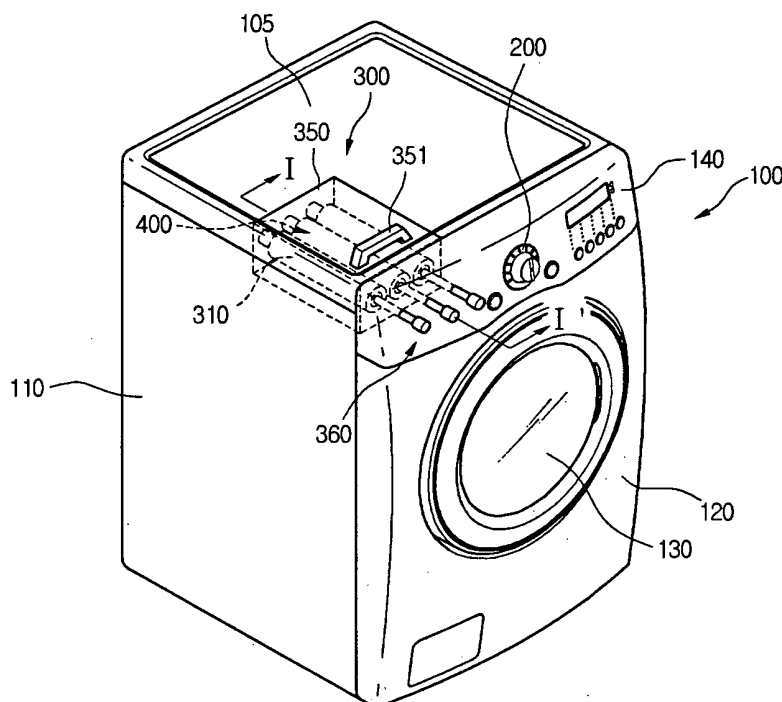

EP 1 731 654 A1

Description

[0001] The present invention relates to a washing machine, and more particularly, to a detergent dispensing apparatus of a washing machine, which can effectively dispense the detergent.

[0002] Generally, a drum-type washing machine performs its washing cycle by manipulating a control unit provided at a front portion. The drum-type washing machine includes a detergent dispensing container for dispensing a detergent and/or softener during the washing cycle. A door is formed on the front portion of the drum-type washing machine. A tub is installed inside of the washing machine and a drum is rotatably installed in the tub. The door is opened and the laundry is loaded in the drum, after which the water and detergent are supplied into the drum. The drum rotates by a driving motor to wash the laundry.

[0003] A typical drum-type washing machine includes a main body formed in a predetermined shape, a drum installed inside of the main body, a tub for enclosing the drum and reserving the washing water, a driving motor for rotating the drum, a detergent container for dispensing the detergent, a water supply pipe connected to the detergent container to supply the washing water or the washing water mixed with the detergent, a drain pipe for draining the used washing water in the washing cycle to an external side, and a pump and drain hose connected to the drain pipe to forcibly drain the washing water.

[0004] When the drum loaded with the laundry and washing water rotates, the laundry is lifted and falls repeatedly, in the course of which the dirt is removed from the laundry by the friction with the washing water. The drum-type washing machine has been improved in its function. For example, a heat-drying function is added to the drum-type washing machine.

[0005] In the conventional washing machine, the detergent dispensing container for dispensing the detergent and softener is formed on the front portion, i.e., the front left-upper portion thereof. The user withdraws the detergent container from the washing machine and fills the detergent container with a proper type and amount of the detergent. Since the laundry may be formed of a variety of materials, a proper detergent must be selected according to the materials of the laundry. Therefore, the user must select the proper amount or type of detergent according to an amount and material of the laundry and fill the same into the detergent dispensing container.

[0006] The filling of the detergent with the detergent dispensing container by himself/herself is troublesome for the user. That is, the user selects the proper type of the detergent, measures the proper amount using, for example, a measuring spoon, and dispenses the measured detergent to the detergent dispensing container by himself/herself. In this case, it is difficult to accurately dispense the detergent and the detergent. Thus, the detergent may pollute around the washing machine. The measuring spoon must be frequently cleaned. This is

troublesome for the user.

[0007] Accordingly, the present invention is directed to a detergent dispensing apparatus of a washing machine, which substantially obviate one or more problems due to limitations and disadvantages of the related art.

[0008] It is an object of the present invention to provide a detergent dispensing apparatus that can easily select a type and amount of the detergent and reliably dispense the detergent.

[0009] It is another object of the present invention to provide a detergent dispensing apparatus that can accurately control the dispensing of a detergent.

[0010] Additional advantages, objects, and features of the invention will be set forth in part in the description which follows and in part will become apparent to those having ordinary skill in the art upon examination of the following or may be learned from practice of the invention. The objectives and other advantages of the invention may be realized and attained by the structure particularly pointed out in the written description and claims hereof as well as the appended drawings.

[0011] To achieve these objects and other advantages and in accordance with the purpose of the invention, as embodied and broadly described herein, there is provided a detergent dispensing apparatus of a washing machine, including: a main body of the washing machine; a detergent cartridge separately received in the main body and storing a detergent therein; a detergent outlet formed on the detergent cartridge to define a detergent dispensing passage; and an opening/closing assembly for selectively opening and closing the detergent outlet.

[0012] In another aspect of the present invention, there is provided a detergent dispensing apparatus of a washing machine, including: a main body of the washing machine; a cartridge receiving body formed on the main body; a detergent cartridge separately received in the cartridge receiving body and storing a detergent therein; a detergent outlet form on the detergent cartridge to define a detergent dispensing passage; and a cap for opening/closing the detergent outlet.

[0013] In still another aspect of the present invention, there is provided a detergent dispensing apparatus of a washing machine, including: a main body of the washing machine; a drawer insertion portion formed on the main body; a cartridge receiving drawer separately inserted in the drawer insertion portion; and a detergent cartridge separately received the cartridge receiving drawer and storing a detergent therein.

[0014] According to the present invention, the dispensing of the detergent or softener can be effectively realized and the initial installed and replacement of the detergent cartridge can be easily realized.

[0015] In addition, when there is no need to dispense the detergent (i.e., in a rinsing or drying cycle), the dispensing of the detergent can be prevented. Furthermore, since the detergent outlet is selectively opened, the detergent hardening phenomenon by the moisture that may be introduced through the detergent outlet can be mini-

mized.

[0016] It is to be understood that both the foregoing general description and the following detailed description of the present invention are exemplary and explanatory and are intended to provide further explanation of the invention as claimed.

[0017] The accompanying drawings, which are included to provide a further understanding of the invention, are incorporated in and constitute a part of this application, illustrate embodiments of the invention and together with the description serve to explain the principle of the invention. In the drawings:

[0018] FIG. 1 is a perspective view of a drum-type washing machine having a detergent dispensing apparatus according to an embodiment of the present invention;

[0019] FIG. 2 is a sectional view taken along line I-I' of FIG. 1, illustrating a cartridge receiving module;

[0020] FIG. 3 is a sectional view of a detergent cartridge of the detergent dispensing apparatus of FIG. 1, before it is received in a cartridge receiving chamber;

[0021] FIG. 4 is a sectional view of the detergent cartridge of FIG. 3, when it is received in the cartridge receiving chamber;

[0022] FIG. 5 is a sectional view of a state where the detergent cartridge of FIG. 4 is pressed to dispense the detergent;

[0023] FIG. 6 is a sectional view of a state where the pressing of the detergent cartridge of FIG. 5 is stopped to complete the dispensing of the detergent;

[0024] FIG. 7 is a perspective view of a drum-type washing machine having a detergent dispensing apparatus according to another embodiment of the present invention;

[0025] FIG. 8 is a vertical sectional view of a cartridge receiving module of FIG. 7;

[0026] FIG. 9 is a sectional view of a detergent cartridge of the detergent dispensing apparatus of FIG. 7, before it is received in a cartridge receiving drawer;

[0027] FIG. 10 is a sectional view of the detergent cartridge of FIG. 9, when it is received in the cartridge receiving drawer;

[0028] FIG. 11 is a sectional view of a state where the cartridge receiving drawer is inserted in a drawer insertion portion of FIG. 10;

[0029] FIG. 12 is a sectional view of a state where the detergent cartridge of FIG. 11 is pressed to dispense the detergent; and

[0030] FIG. 13 is a sectional view of a state where the pressing of the detergent cartridge of FIG. 12 is stopped to complete the dispensing of the detergent.

[0031] Reference will now be made in detail to the preferred embodiments of the present invention, examples of which are illustrated in the accompanying drawings.

[0032] FIG. 1 is a perspective view of a drum-type washing machine having a detergent dispensing apparatus according to an embodiment of the present invention.

[0033] Referring to FIG. 1, a drum-type washing machine 100 comprises a cabinet 110 defining an appearance of the drum-type washing machine 100, a front cover 120 mounted on a front portion of the cabinet 110, and a top cover 105 for covering a top portion of the drum-type washing machine.

[0034] The drum-type washing machine 100 further includes a door 130 mounted on a center portion of the front cover 120, a dial knob mounted on the upper portion of the front cover 120 to input a washing mode, and a control panel 140 mounted on an upper portion of the front cover 120 and provided with a variety of display units.

[0035] A detergent dispensing apparatus according to an embodiment of the present invention is disposed on an upper portion of the drum-type washing machine 100. The detergent dispensing apparatus includes a detergent cartridge 400 and a cartridge receiving module 300 for receiving the detergent cartridge 400. The cartridge receiving module 300 includes a cartridge receiving chamber 311, a cover 350 for covering the cartridge receiving chamber 311, and a piston 360 for pressing the detergent cartridge 400 to dispense the detergent.

[0036] Meanwhile, the mounting location of the dial knob 200 and the control panel 140 are not limited to the upper portion of the front cover 120. For example, the dial knob 200 and the control panel 140 may be formed on a portion of the top cover 105.

[0037] The operation of the drum-type washing machine will be described hereinafter.

[0038] The door 130 is opened and the laundry is loaded in the drum. Then, the door 130 is closed and the washing mode is inputted using the dial knob 200. Then, the operation button is turned on and the detergent is dispensed by manipulating the detergent dispensing apparatus.

[0039] When the detergent is dispensed, the washing cycle is performed. After the washing cycle is finished, if required, a drying cycle may be further performed.

[0040] Meanwhile, according to this embodiment, the detergent dispensing apparatus is improved so that the user can easily dispense the detergent and an amount of the detergent dispensed can be accurately controlled. This will be described later.

[0041] FIG. 2 is a sectional view taken along line I-I' of FIG. 1, illustrating a cartridge receiving module.

[0042] Referring to FIG. 2, the cartridge receiving module 300 includes a detergent cartridge 400 for storing the detergent and/or the softener, a cartridge receiving body 310 provided with the cartridge receiving chamber 311 in which the detergent cartridge 400 is received, and the cover 350 for covering the cartridge receiving chamber 311. The cartridge receiving body 310 provided with the cartridge receiving chamber 311 and the cover 350 constitute the cartridge receiving unit.

[0043] That is, the detergent cartridge 400 includes the cartridge body 410, a detergent storage chamber 411 formed in the cartridge body 410 to store the detergent,

and a detergent outlet 412 formed in front of the detergent storage chamber 411 to exhaust the detergent. The detergent cartridge 400 further includes a detergent outlet forming portion 413 forming the detergent outlet 412, a press plate 414 inserted in a rear portion of the cartridge body 410 and pressurized by the piston 360.

[0044] The detergent cartridge 400 stores the detergent or softener in the detergent storage chamber 411. The detergent cartridge 400 is a monolithic body itself, which can be a unit for transportation and handling. This monolithic body of the detergent cartridge 400 is detachably attached in the cartridge receiving chamber 311. Therefore, when the detergent or softener stored in the detergent cartridge 400 is fully consumed, the detergent cartridge 400 is removed from the cartridge receiving chamber 311 so that it can be replaced with a new one. That is, since the detergent or softener can be handled by a unit of the detergent cartridge 400, it is easy to handle the same.

[0045] The cartridge receiving body 310 is further provided with a detergent inlet 213 through which the detergent is introduced in response to the detergent outlet 412 as well as the cartridge receiving chamber 311 in which the detergent cartridge 400 is disposed. The cartridge receiving body 310 is provided with a detergent inlet forming portion 313 for forming the detergent inlet 312 and a sealing member 314 for sealing a space between the detergent outlet forming portion 413 and the detergent outlet forming portion 313.

[0046] The cartridge receiving body 310 includes a first cartridge fixing portion 316 and a second cartridge fixing portion 318 for fixing the detergent cartridge 400 inserted in the cartridge receiving body 310.

[0047] As shown in FIG. 2, the cartridge fixing portions 316 and 318 may be formed by stepping a bottom of the cartridge receiving body 310. The first and/or second cartridge fixing portion 316 and/or 318 may be rounded and chamfered at their surfaces that face the detergent cartridge 400.

[0048] In addition, a detergent dispensing passage 331 and a detergent dispensing passage forming portion 330 are formed in front of the cartridge receiving body 310. The detergent dispensing passage 331 communicates with the detergent inlet 312 formed on a front portion of the cartridge receiving body 310 to allow the detergent to be dispensed into the tub. Between the detergent dispensing passage 331 and the detergent inlet 312, a cap 334 for opening and closing the detergent inlet 312, a cap support projection 333 for supporting the cap 334, and a guide portion 332 for guiding the cap support projection 333 are formed. The cap 334 is installed inside of the guide portion 332 such that it moves forward or rearward according to a pressure difference between an elastic force of a spring 335 and a pressure applied by a material introduced into the detergent inlet 312, thereby opening and closing the detergent inlet 312.

[0049] The cap 334, the cap support projection 333, the guide portion 332, and the spring 335 constitute an

opening/closing assembly for closing and opening the detergent outlet 412.

[0050] The cover 350 is connected to a side of the cartridge receiving body 310 to cover the cartridge receiving chamber 311. That is, the cover 350 is provided with a pivot portion 352 in which a hinge shaft 353 is inserted so that the cover 350 can pivot within a predetermined angle range. The cartridge receiving body 310 supports the pivot portion 352 and the hinge 353 is coupled to the cartridge receiving body 310.

[0051] The cover 350 pivots about the hinge shaft 353 within a predetermined angle to open and close the cartridge receiving chamber 311. Meanwhile, a handle 351 is formed on an upper portion of the cover 350 so that the user can easily open and close the cover 350 using the handle 351.

[0052] Meanwhile, the detergent cartridge 400 received in the cartridge receiving chamber 311 is pressurized by the piston 360 to dispense the detergent stored therein. That is, the piston 360 a rear end portion 363 to which an outer force is applied, a connecting portion 362 for transferring the outer force applied to the rear end portion 363, and a head portion 361 pressing the press plate 414 using the outer force transferred from the connecting portion 362.

[0053] The piston 360 is inserted into the rear portion of the cartridge receiving body 310 to reciprocally move and pressurize the detergent cartridge 400.

[0054] The piston 360 is exemplary only and thus the present invention is not limited to this. A variety of pressurizing structures may be used.

[0055] The detergent dispensing apparatus according to this embodiment will be described in more detail with reference to FIGs. 3 through 6.

[0056] FIGs. 3 through 6 are sectional views illustrating an operation of the detergent dispensing apparatus according to this embodiment.

[0057] That is, FIG. 3 is a sectional view of a detergent cartridge of the detergent dispensing apparatus of FIG. 1, before it is received in a cartridge receiving chamber, FIG. 4 is a sectional view of the detergent cartridge of FIG. 3, when it is received in the cartridge receiving chamber, FIG. 5 is a sectional view of a state where the detergent cartridge of FIG. 4 is pressed to dispense the detergent, and FIG. 6 is a sectional view of a state where the pressing of the detergent cartridge of FIG. 5 is stopped to complete the dispensing of the detergent.

[0058] Referring first to FIG. 3, the cover 350 pivots about the hinge shaft 353 by a predetermined angle to open the cartridge receiving chamber 311. Then, the detergent cartridge 400 that will be received in the cartridge receiving chamber 311 is prepared. The cartridge receiving chamber 311 stores a designed detergent or softener.

[0059] Then, as shown in FIG. 4, the detergent cartridge 400 is received in the cartridge receiving chamber 311. Then, the detergent outlet formed on the detergent cartridge 400 and the detergent inlet 312 formed on the cartridge receiving body 310 communicate with each oth-

er. At this point, the detergent outlet forming portion 413 and the detergent inlet forming portion 313 press the both sides of the sealing member 314 at a predetermined pressure to deform the sealing member 314, thereby sealing a space between the detergent outlet forming portion 413 and the detergent inlet forming portion 313.

[0060] In addition, the front lower and rear lower portions of the detergent cartridge 400 are respectively fitted on the first and second cartridge fixing portions 316 and the 318 so that the detergent cartridge 400 can be stably fixed in the cartridge receiving chamber 311. At this point, the corners of the first and second cartridge fixing portions 316 and 318 are rounded or chamfered so that the detergent cartridge 400 can be easily fitted.

[0061] In a state where the detergent cartridge 400 is fitted, the cover 350 pivots to cover the cartridge receiving chamber 311. Then, the infiltration of foreign objects into the cartridge receiving chamber 311 from the external side can be prevented by the cover 350 while the detergent cartridge 400 is protected from the external shock.

[0062] Then, as shown in FIG. 5, the piston 360 is pressed. That is, when an outer force is applied to a rear end portion 363 of the piston, it is transmitted to the head portion 361 through the connection portion 362 to press the press plate 414, thereby moving the press plate 414 forward. As a result, the material stored in the detergent storage chamber 411 is pressurized by the press plate 414 and the pressure is transmitted to the detergent outlet 412. The transmitted pressure presses the cap 334 closing the detergent inlet 312 connected to the detergent outlet 412. At this point, when the pressure applied to the cap 334 is greater than the elastic force of the spring 335, the cap 334 is pushed to open the detergent inlet 312 while compressing the spring 335. Then, the material stored in the detergent storage chamber 411 is dispensed along the detergent dispensing passage 331 into the tub via the detergent outlet 412 and the detergent inlet 312 communicating with the detergent outlet 412.

[0063] After the above, when a desired amount of the material stored in the detergent cartridge 400 is dispensed, as shown in FIG. 6, the pressuring by the piston 360 is stopped. Then, the pressure applied to the cap 334 is released such that the elastic force of the spring 335 becomes greater than the pressure applied to the cap 334. As a result, the cap 334 is pushed toward the detergent inlet 312. Then, the detergent inlet 312 is closed again by the cap 334, thereby completing the dispensing of the material contained in the detergent cartridge 400.

[0064] Through the above-described processes, the dispensing of the detergent or softener into the tub can be easily and accurately realized.

[0065] Meanwhile, when it is intended to dispense the material contained in the detergent cartridge 400 for other washing cycle, the detergent or softener can be dispensed by simply pressing the piston 360. That is, as far as the detergent or softener is remained in the detergent cartridge 400, the detergent or softener can be conven-

iently dispensed into the tub by simply pressing the piston 360 without replacing the detergent cartridge.

[0066] When the material contained in the detergent cartridge 400 is almost consumed, the cover 350 is opened and the detergent cartridge 400 is removed from the cartridge receiving chamber 311. Then, a new detergent cartridge 400 is received in the cartridge receiving chamber 311 so that the detergent and softener can be dispensed again. Therefore, there is no need to dip up and measure the detergent contained in a detergent container disposed near the washing machine to dispense the measured detergent or softener. That is, according to the present invention, by simply pressing the piston 360, a desired amount of the detergent or softener can be dispensed.

[0067] A detergent dispensing apparatus according to another embodiment of the present invention will now be described with reference to FIGs. 7 through 13. Throughout the drawings, the description of the elements identical to those of the foregoing embodiment will be omitted.

[0068] FIG. 7 is a perspective view of a drum-type washing machine having a detergent dispensing apparatus according to another embodiment of the present invention.

[0069] Referring to FIG. 7, a detergent dispensing apparatus according to this embodiment is disposed on an upper portion of the drum-type washing machine 100. The detergent dispensing apparatus includes a detergent cartridge 400 and a cartridge receiving module 300 for receiving the detergent cartridge 400. The cartridge receiving module 300 includes a drawer insertion portion 500, a cartridge receiving drawer 370 inserted in the drawer insertion portion 500, and the detergent cartridge 400 receiving in the cartridge receiving drawer 370. A handle 372 is formed on the cartridge receiving drawer for the user's convenience. The cartridge receiving drawer 370 and the drawer insertion portion 500 define the cartridge receiving portion. Meanwhile, the cartridge receiving module 300 includes a piston pressing the detergent cartridge 400 to dispense the detergent.

[0070] FIG. 8 is a vertical sectional view of the cartridge receiving module of FIG. 7.

[0071] Referring to FIG. 8, the cartridge receiving module 300 includes a detergent cartridge 400 for storing the detergent and/or the softener, a cartridge receiving drawer 370 in which a drawer body 371 for receiving the detergent cartridge 400 is formed, and the drawer insertion portion 500 in which the cartridge receiving drawer 370 is inserted.

[0072] As described above, the detergent cartridge 400 includes a cartridge body 410, a detergent storage chamber 411 formed in the cartridge body 410 to store the detergent, and a detergent outlet 412 formed in front of the detergent storage chamber 411 to exhaust the detergent. The detergent cartridge 400 further includes a detergent outlet forming portion 413 forming the detergent outlet 412, a press plate 414 inserted in a rear portion of the cartridge body 410 and pressurized by the piston

360.

[0073] The detergent cartridge 400 is a monolithic body itself, which can be a unit for transportation and handling. This monolithic body of the detergent cartridge 400 is detachably attached in the cartridge receiving drawer 370. That is, since the detergent or softener can be handled by a unit of the detergent cartridge 400, it is easy to handle the same.

[0074] The cartridge receiving drawer 370 includes the drawer body 371 defining a space for receiving the detergent cartridge 400, and a first cartridge fixing portion 372 and a second cartridge fixing portion 3373 for fixing the detergent cartridge 400 inserted in the cartridge receiving drawer 370. As shown in the drawing, the cartridge fixing portions 372 and 373 may be formed by stepping a bottom of the cartridge drawer body 371. The first and/or second cartridge fixing portion 372 and/or 373 may be rounded and chamfered at their surfaces that face the detergent cartridge 400.

[0075] The detergent cartridge 400 is inserted in the cartridge receiving drawer 370. This assembly can be separately inserted in the drawer insertion portion 500. Therefore, there is a need to replace the detergent cartridge 400, the cartridge receiving drawer 370 is withdrawn and the detergent cartridge 400 is replaced with a new one.

[0076] The drawer insertion portion 500 includes a drawer insertion body 510 and a drawer insertion chamber 511 formed on the drawer insertion body 510 to receive the cartridge receiving drawer 370. The drawer insertion portion 500 further includes a cap for selectively closing the detergent outlet 412 and a sealing member 514 for sealing a space between the drawer insertion body 510 and the detergent outlet forming portion 413. The drawer insertion portion 500 is provided with a detergent dispensing passage 531 formed on a front portion of the drawer insertion portion 500 to allow the detergent to be dispensed into the tub and the detergent dispensing passage forming portion 530 forming the detergent dispensing passage 531. The detergent dispensing passage 531 is provided at its inlet portion with a cap supporting projection 533 supporting the cap 534 and a guide portion 532 for guiding the cap support projection 533.

[0077] The cap 534 opens and closes the detergent dispensing passage 531 by moving frontward and rearward by a pressure difference between the elastic force of the spring 535 applying a predetermined pressure to the cap support projection 533 and the pressure of the material exhausted through the detergent outlet 412.

[0078] The detergent cartridge 400 is pressurized by the piston 360 to exhaust the detergent stored therein. That is, the piston 360 a rear end portion 363 to which an outer force is applied, a connecting portion 362 for transferring the outer force applied to the rear end portion 363, and a head portion 361 pressing the press plate 414 using the outer force transferred from the connecting portion 362. The piston 360 is inserted into the rear portion of the cartridge receiving body 310 to reciprocally move

and pressurize the detergent cartridge 400.

[0079] The detergent dispensing apparatus according to this embodiment will be described in more detail with reference to FIGs. 9 through 13.

[0080] FIGs. 9 through 13 are sectional views illustrating an operation of the detergent dispensing apparatus according to this embodiment.

[0081] That is, FIG. 9 is a sectional view of the detergent cartridge of the detergent dispensing apparatus of FIG. 7, before it is received in the cartridge receiving drawer, FIG. 10 is a sectional view of the detergent cartridge of FIG. 9, when it is received in the cartridge receiving drawer, FIG. 11 is a sectional view of a state where the cartridge receiving drawer is inserted in the drawer insertion portion of FIG. 10, FIG. 12 is a sectional view of a state where the detergent cartridge of FIG. 11 is pressed to dispense the detergent, and FIG. 13 is a sectional view of a state where the pressing of the detergent cartridge of FIG. 12 is stopped to complete the dispensing of the detergent.

[0082] Referring first to FIG. 9, the cartridge receiving drawer 370 is removed from the drawer insertion portion 500. At this point, the cartridge receiving drawer 370 may be completely separated from the drawer insertion portion 500 or a front portion thereof maintains its insertion state in the drawer insertion portion 500. The detergent cartridge 400 storing a desired detergent or softener is prepared.

[0083] Then, as shown in FIG. 10, the detergent cartridge 400 is received in the cartridge receiving drawer 370. The front lower and rear lower portions of the detergent cartridge 400 are respectively fitted on the first and second cartridge fixing portions 372 and the 3373 so that the detergent cartridge 400 can be stably fixed in the cartridge receiving drawer 370. At this point, the corners of the first and second cartridge fixing portions 372 and 373 are rounded or chamfered so that the detergent cartridge 400 can be easily fitted.

[0084] Next, as shown in FIG. 11, the cartridge receiving drawer 370 is inserted in the drawer insertion chamber 511 so that the detergent outlet 412 can communicate with the detergent inlet formed on the drawer insertion body 510. At this point, the detergent outlet forming portion 413 and the detergent inlet forming portion 413 press the both sides of the sealing member 514 at a predetermined pressure to deform the sealing member 514, thereby sealing a space between the detergent outlet forming portion 413 and the drawer insertion portion body 510.

[0085] In a state where the detergent cartridge 400 is inserted, the cap 534 is biased by the spring 535 to close the detergent dispensing passage 531. Therefore, even when the cartridge receiving drawer 370 in which the detergent cartridge 400 is inserted is completely installed in the drawer insertion chamber 511, the internal material of the detergent cartridge 400 does not leak.

[0086] Next, as shown in FIG. 12, the piston 360 is pressed. That is, when an outer force is applied to a rear

end portion 363 of the piston, it is transmitted to the head portion 361 through the connection portion 362 to press the press plate 414, thereby moving the press plate 414 forward. As a result, the material stored in the detergent storage chamber 411 is pressurized by the press plate 414 and the pressure is transmitted to the detergent outlet 412. The transmitted pressure presses the cap 534. At this point, when the pressure applied to the cap 534 is greater than the elastic force of the spring 535, the cap 334 is pushed to open the detergent dispensing passage 531 while compressing the spring 535. Then, the material stored in the detergent storage chamber 411, is dispensed through the detergent outlet 412 and the detergent dispensing passage 531 communicating with the detergent outlet 412 into the tub.

[0087] After the above, when a desired amount of the material stored in the detergent cartridge 400 is dispensed, as shown in FIG. 13, the pressuring by the piston 360 is stopped. Then, the pressure applied to the cap 534 is released such that the elastic force of the spring 535 becomes greater than the pressure applied to the cap 534. As a result, the cap 534 is pushed toward the detergent cartridge 400. Then, the detergent dispensing passage 531 is closed again by the cap 534, thereby completing the dispensing of the material contained in the detergent cartridge 400.

[0088] Through the above-described processes, the dispensing of the detergent or softener into the tub can be easily and accurately realized.

[0089] Meanwhile, when it is intended to dispense the material contained in the detergent cartridge 400 for other washing cycle, the detergent or softener can be dispensed by simply pressing the piston 360. That is, as far as the detergent or softener is remained in the detergent cartridge 400, the detergent or softener can be conveniently dispensed into the tub by simply pressing the piston 360 without replacing the detergent cartridge.

[0090] When the material contained in the detergent cartridge 400 is almost consumed, the cartridge receiving drawer 370 is withdrawn from the drawer insertion portion 500 and the detergent cartridge 400 is removed from the cartridge receiving drawer 370. Then, a new detergent cartridge 400 is received in the cartridge receiving drawer 370 and the cartridge receiving drawer 370 is inserted in the drawer insertion portion 500 so that the detergent and softener can be dispensed again. Therefore, there is no need to dip up and measure the detergent contained in a detergent container disposed near the washing machine to dispense the measured detergent or softener. That is, according to the present invention, by simply pressing the piston 360, a desired amount of the detergent or softener can be dispensed.

[0091] According to the present invention, since the detergent cartridge is received in the cartridge receiving portion, the dispensing of the detergent can be performed many times. When the material (detergent) is fully consumed, the detergent cartridge is removed from the cartridge receiving portion to be replaced with a new one.

Therefore, the detergent or softener can be repeatedly dispensed by a simple manipulation.

[0092] In addition, since the cartridge receiving portion is designed with a cartridge receiving chamber having a cover or a cartridge receiving drawer, the detergent cartridge can be easily replaced.

[0093] Furthermore, since the opening/closing assembly for opening and closing the detergent outlet of the detergent cartridge is provided, the detergent outlet can be opened only when it is intended to dispense the detergent or softener. Therefore, when there is no need to dispense the detergent (i.e., in a rinsing or drying cycle), the dispensing of the detergent can be prevented.

[0094] In addition, since the detergent outlet is selectively opened, the detergent hardening phenomenon by the moisture that may be introduced through the detergent outlet can be minimized.

[0095] It will be apparent to those skilled in the art that various modifications and variations can be made in the present invention. Thus, it is intended that the present invention covers the modifications and variations of this invention provided they come within the scope of the appended claims and their equivalents.

Claims

1. A detergent dispensing apparatus of a washing machine, **characterized in that**, the detergent dispensing apparatus comprises:
 - a main body of the washing machine;
 - a cartridge receiving body formed on the main body;
 - a detergent cartridge separately received in the cartridge receiving body and storing a detergent therein;
 - a detergent outlet form on the detergent cartridge to define a detergent dispensing passage; and
 - a cap for opening/closing the detergent outlet.
2. The detergent dispensing apparatus according to claim 1, **characterized in that** the cap is opened and closed by a pressure difference between pressures of interior and exterior sides of the detergent outlet.
3. The detergent dispensing apparatus according to any of the preceding claims, **characterized in that** the cap closes the detergent outlet using an elastic force generated by an elastic member.
4. The detergent dispensing apparatus according to any of the preceding claims, **characterized in that** the cartridge receiving body is provided with a guide portion for guiding the movement of the cap.

5. The detergent dispensing apparatus according to claim 4, **characterized in that** the guide portion is provided with a hole along which the cap is guided.
6. The detergent dispensing apparatus according to any of the preceding claims, **characterized in that** the opening/closing assembly- includes a press portion for pressing the cap to selectively open the detergent outlet.
7. The detergent dispensing apparatus according to any of the preceding claims, **characterized in that** the main body is provided with a drawer insertion portion in which the cartridge receiving drawer can be inserted and the detergent cartridge is separately received in the cartridge receiving drawer.
8. The detergent dispensing apparatus according to any of the preceding claims, **characterized in that** detergent dispensing apparatus further comprises a sealing member for sealing a space between the cartridge receiving body and the detergent outlet.
9. The detergent dispensing apparatus according to any of the preceding claims, **characterized in that** the cartridge receiving body is provided with a fixing portion for fixing the detergent cartridge therein.

5

10

15

20

25

30

35

40

45

50

55

【Figure 1】

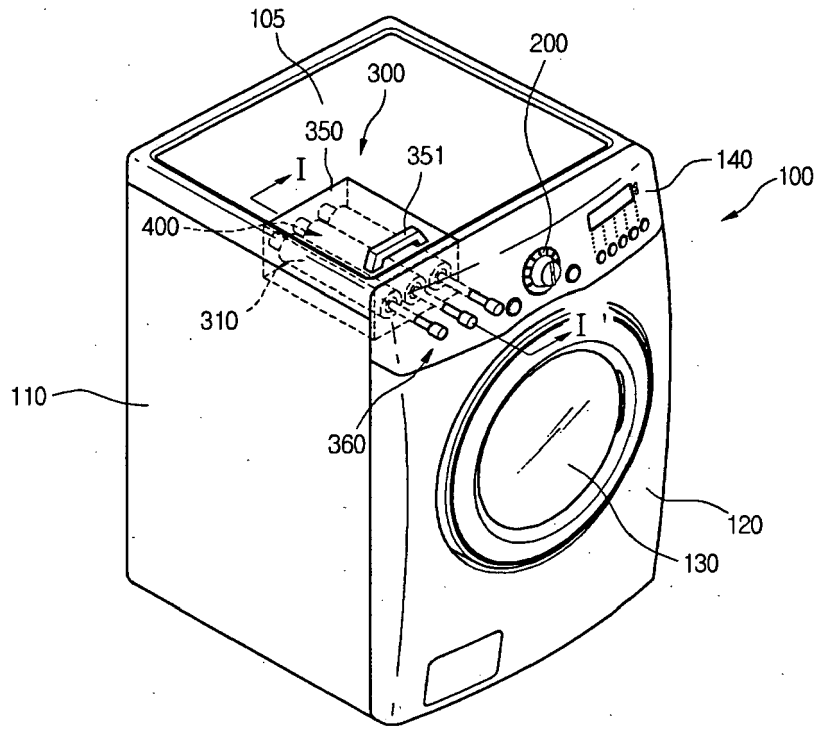

【 Figure 2】

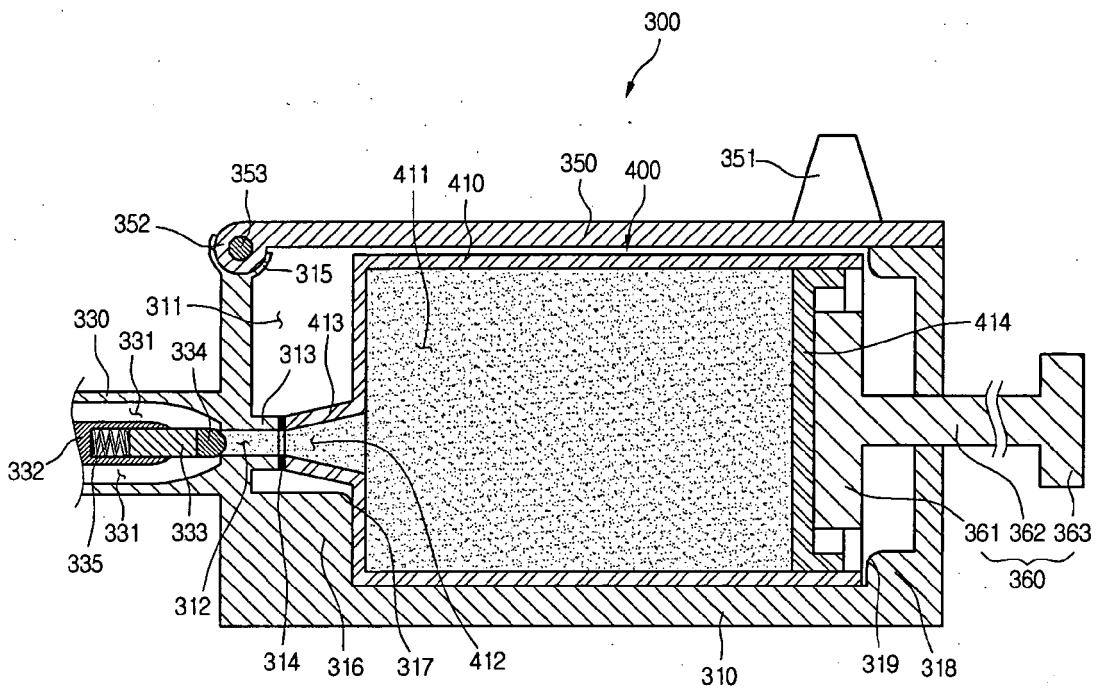

【 Figure 3】

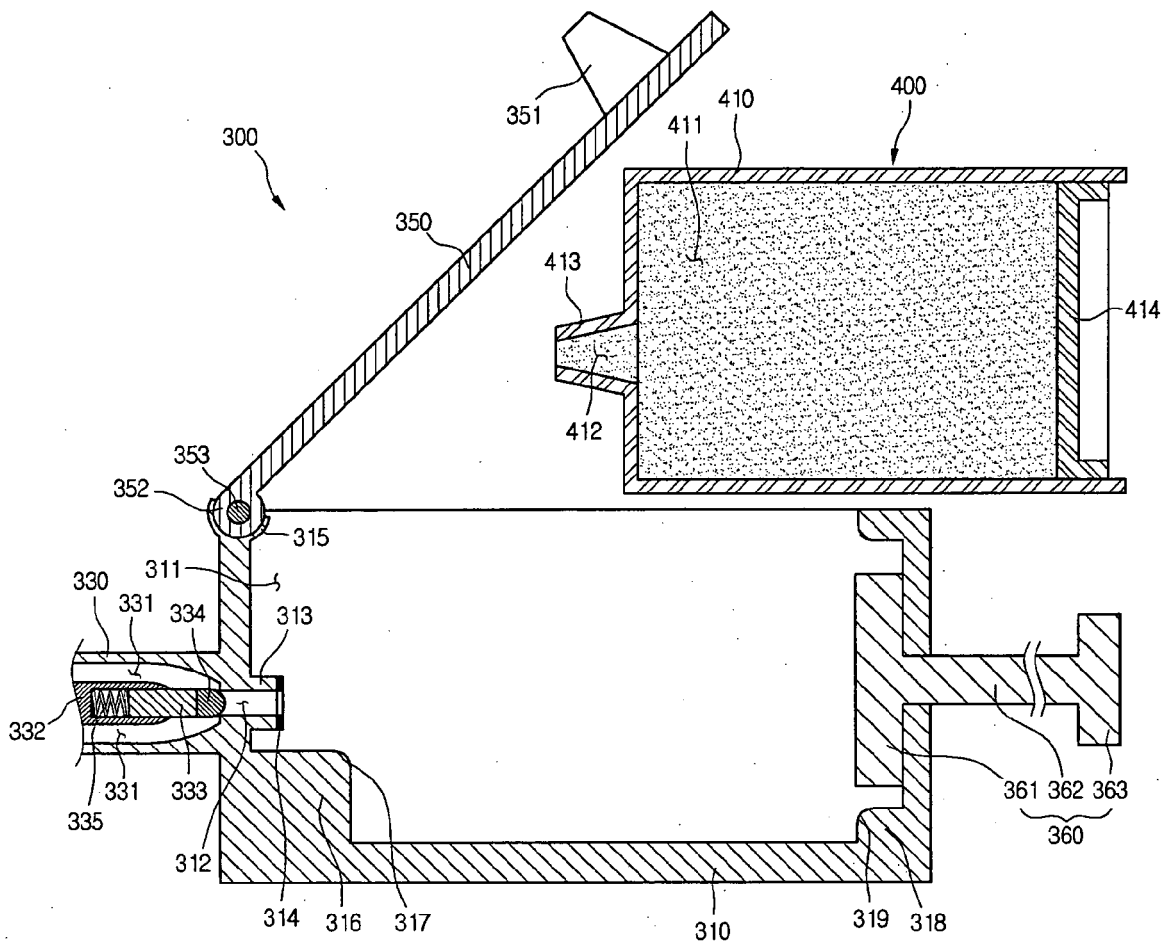

【 Figure 4】

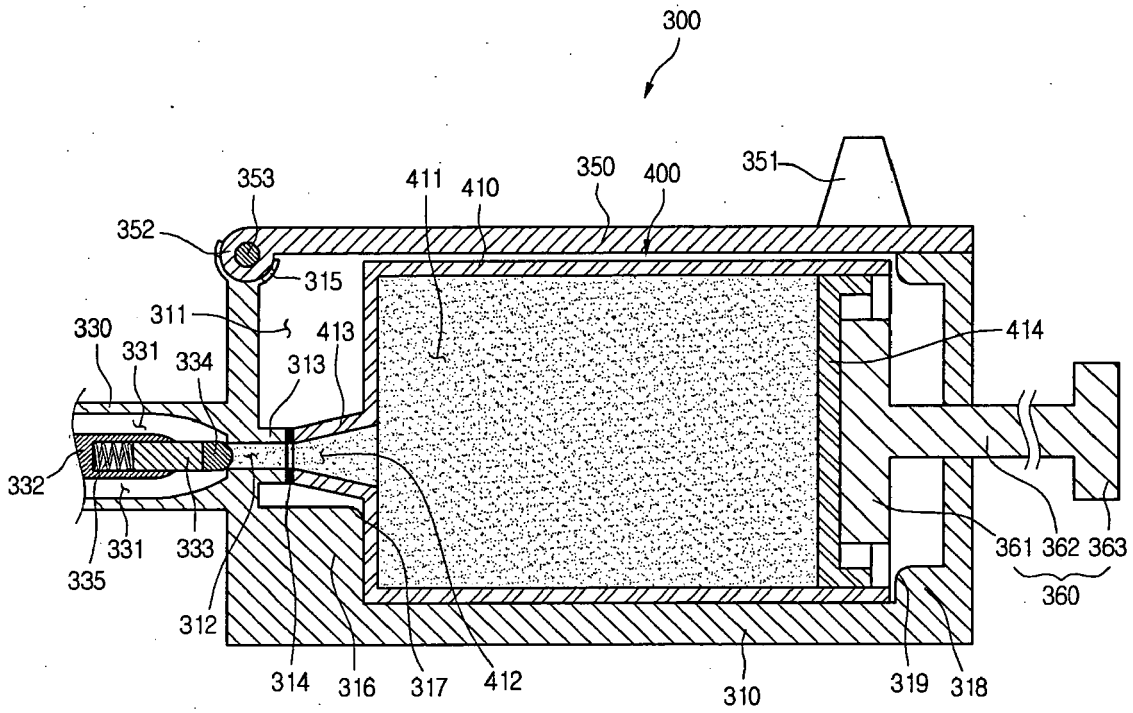

【 Figure 5】

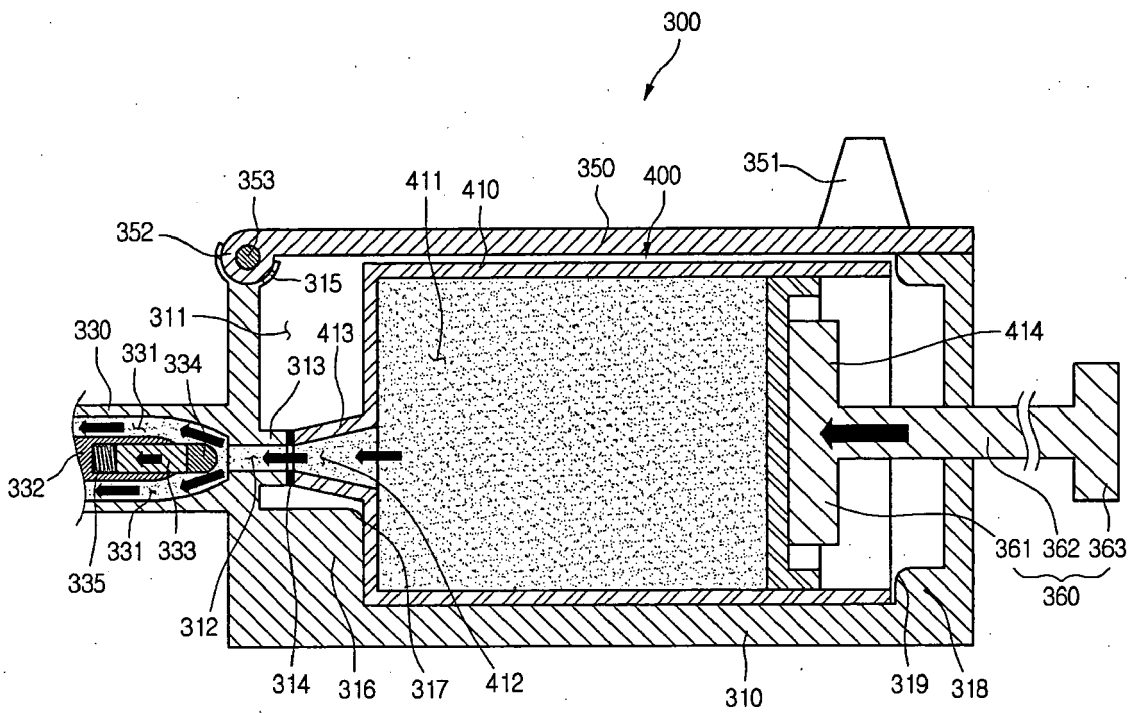

【 Figure 6】

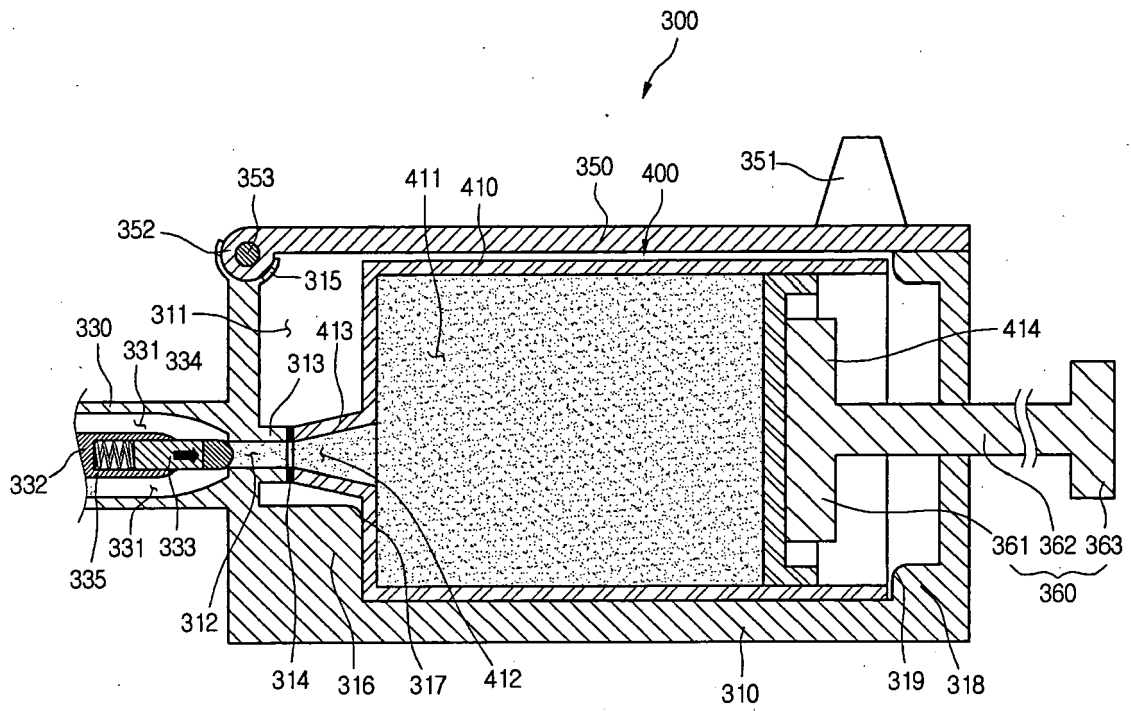

【 Figure 7】

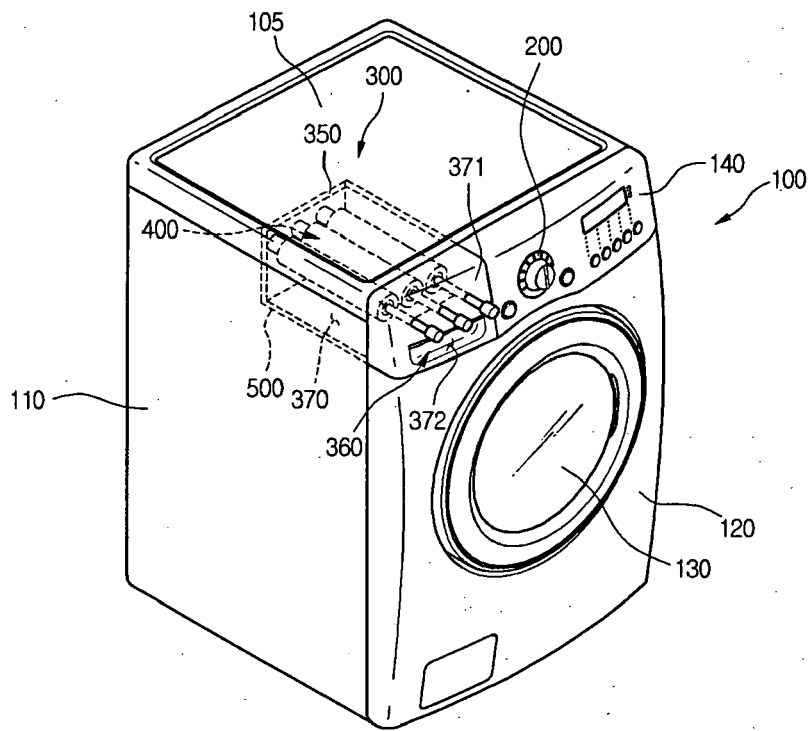

【 Figure 8】

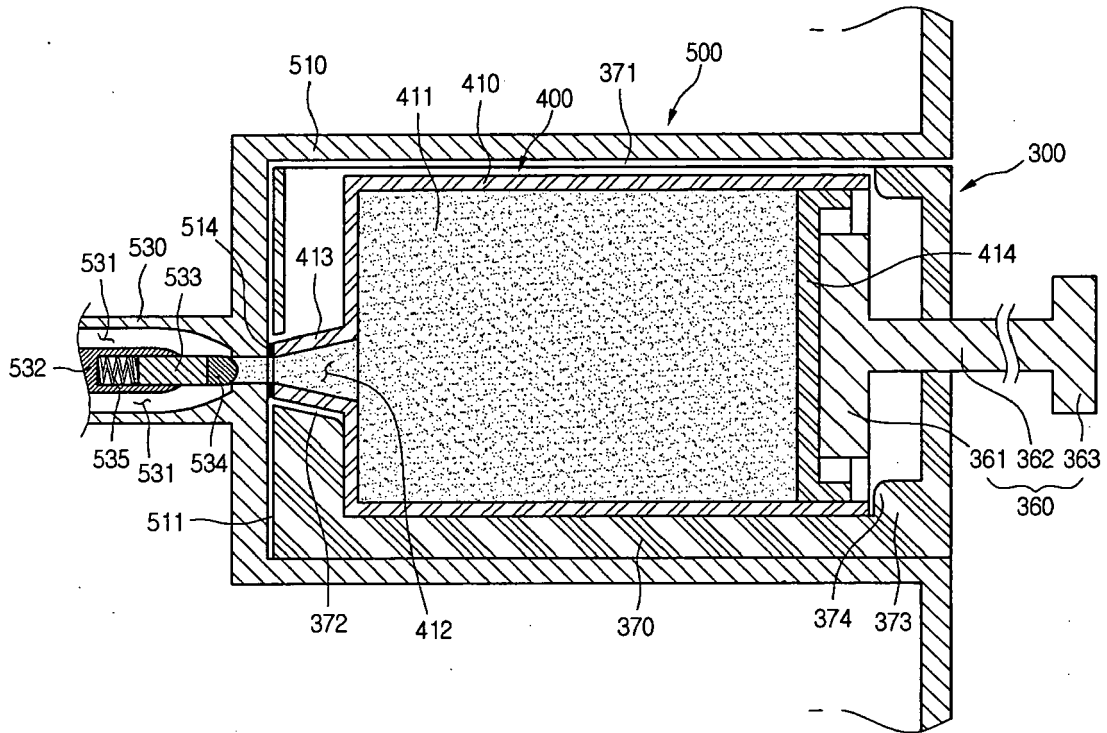

【 Figure 9】

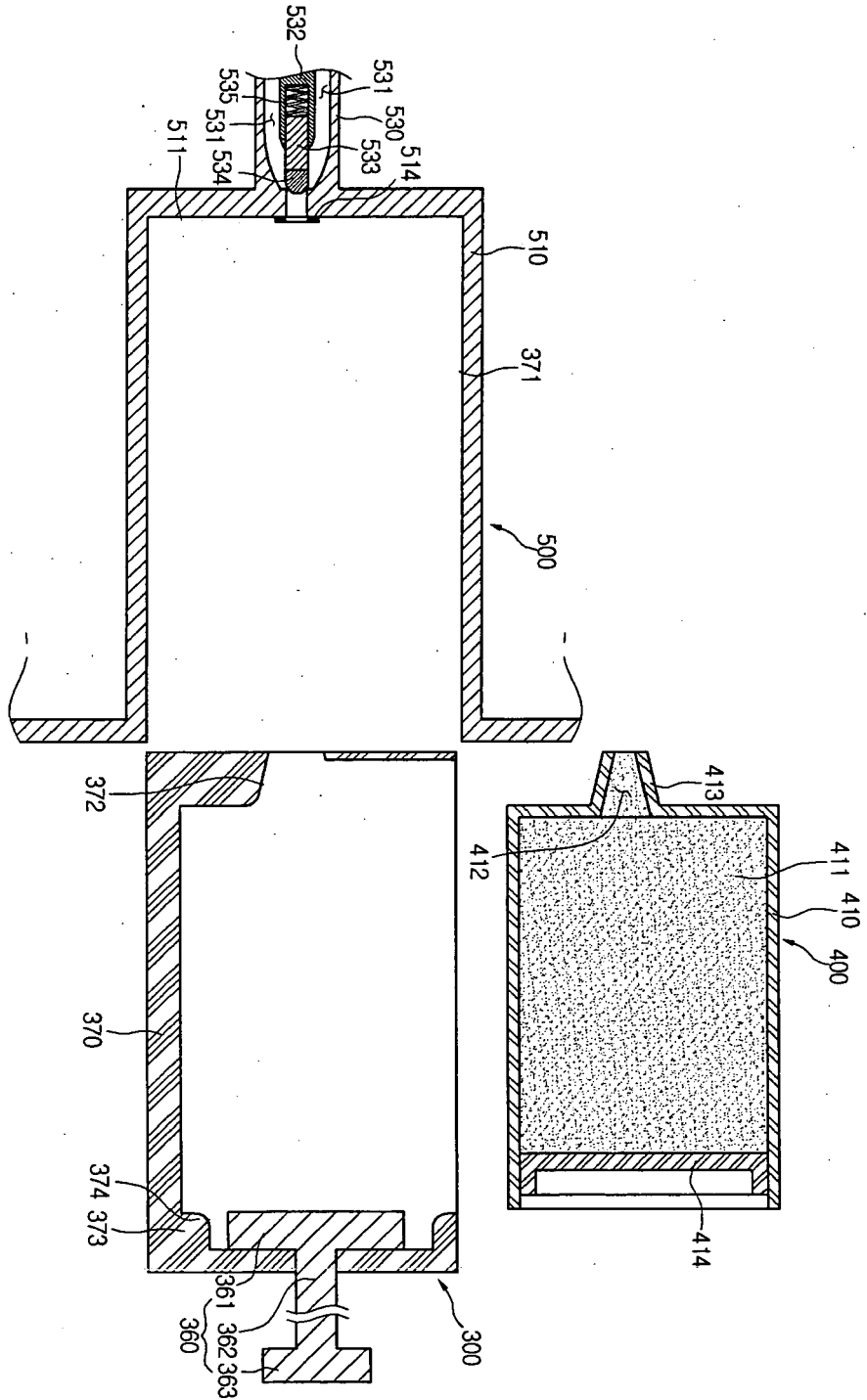

【 Figure 10】

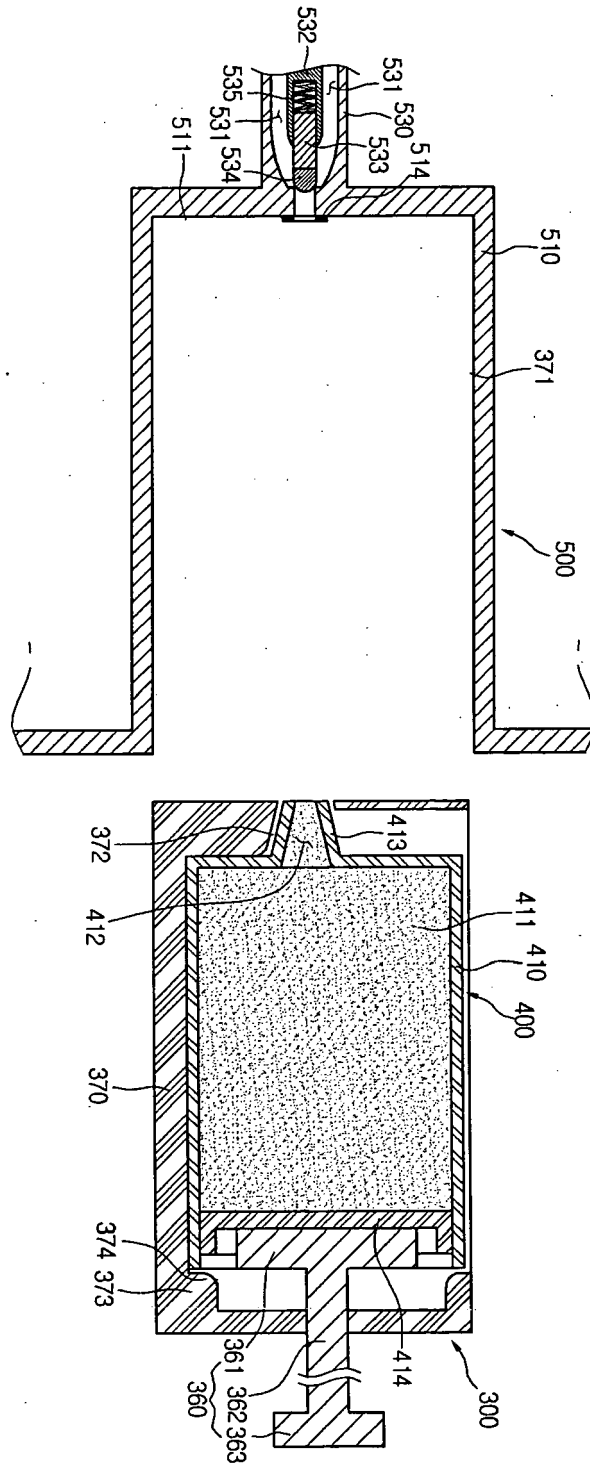

【 Figure 11】

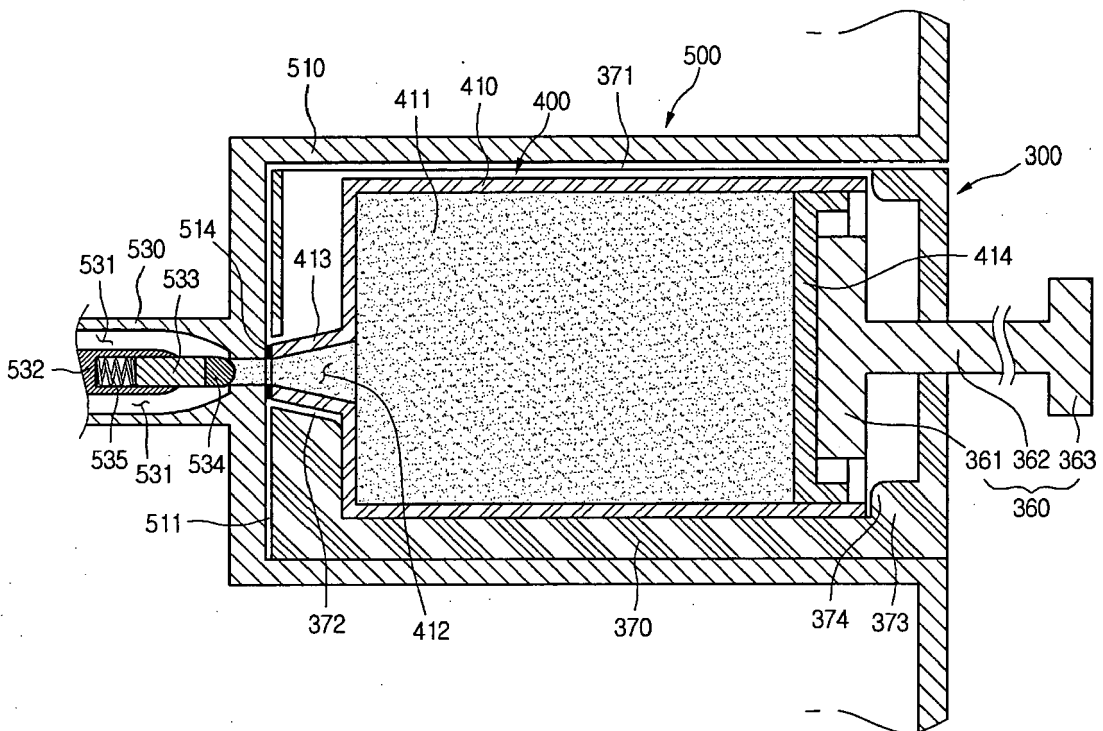

【 Figure 12】

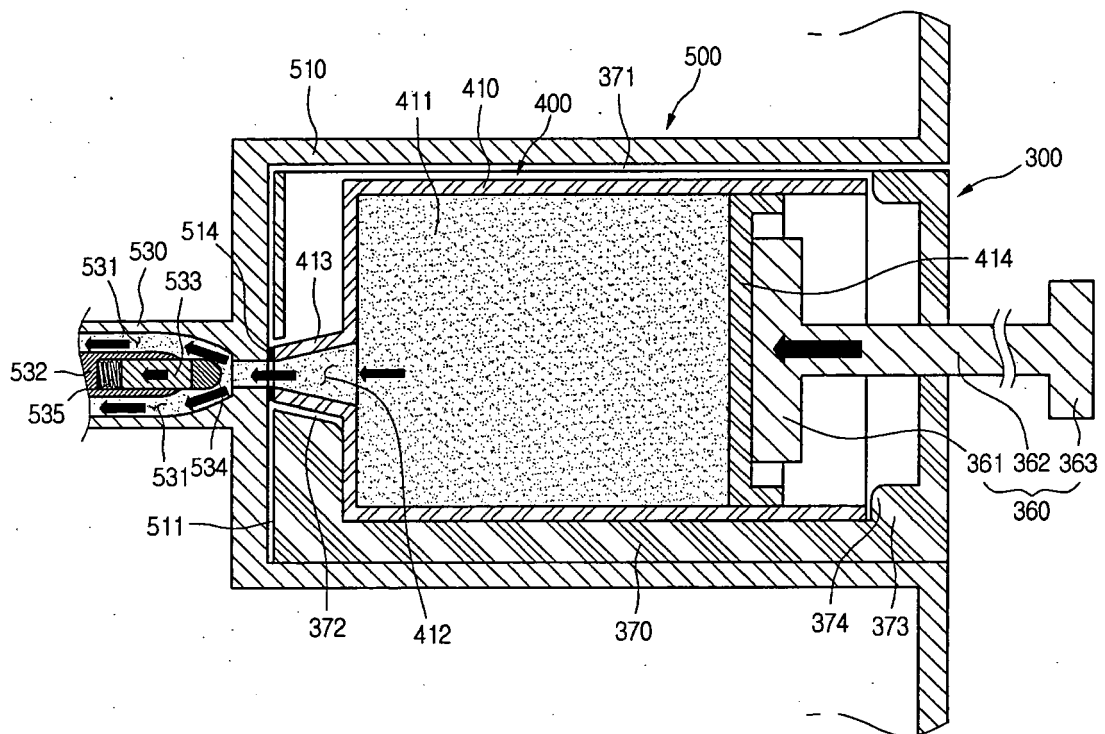

【 Figure 13】

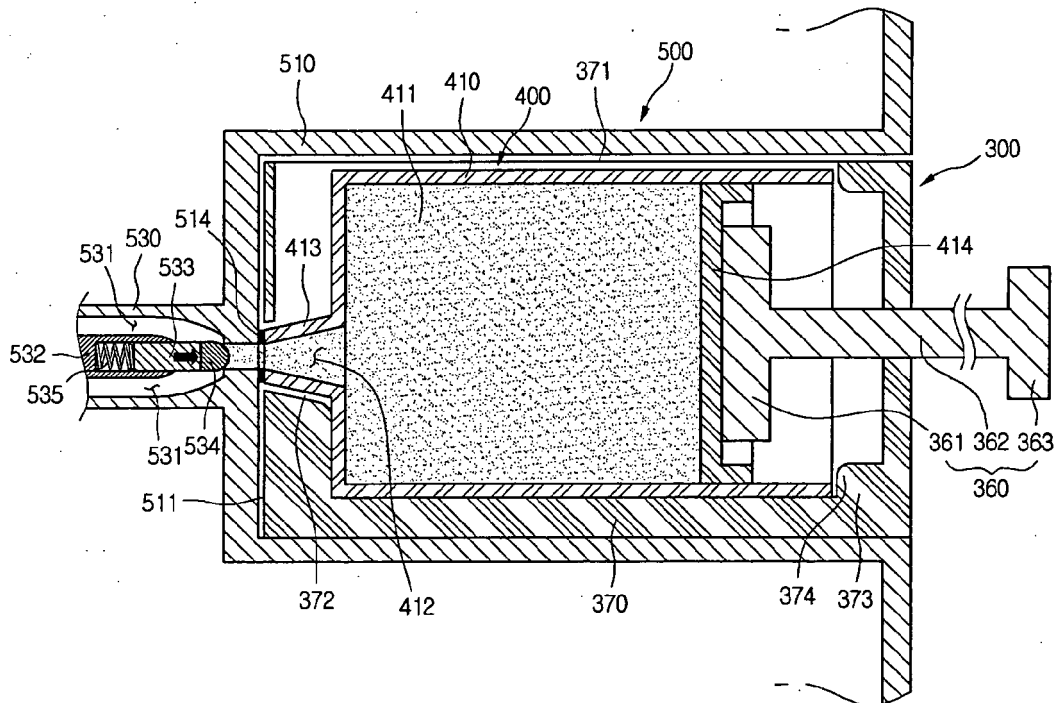



DOCUMENTS CONSIDERED TO BE RELEVANT				
Category	Citation of document with indication, where appropriate, of relevant passages	Relevant to claim	CLASSIFICATION OF THE APPLICATION (IPC)	
X	DE 196 17 471 A1 (HENKEL KGAA, 40589 DUESSELDORF, DE) 13 November 1997 (1997-11-13)	1-6,8,9	INV. D06F39/02	
Y	* the whole document *	7		
Y	----- EP 1 424 428 A (ELBI INTERNATIONAL SPA) 2 June 2004 (2004-06-02) * the whole document *	7		
X	----- WO 02/058528 A (UNILEVER PLC; UNILEVER NV; HINDUSTAN LEVER LIMITED) 1 August 2002 (2002-08-01) * the whole document *	1-6,8,9		
X	----- DE 80 18 995 U1 (BOSCH-SIEMENS HAUSGERAETE GMBH, 7000 STUTTGART) 23 October 1980 (1980-10-23) * page 3, paragraph 2 - page 4, last paragraph; figures *	1,4-6,8,9		
X	----- WO 02/20893 A (ARCELIK A.S; BUEKUELMEZ, BORA; KUTLAY, ENGIN) 14 March 2002 (2002-03-14) * the whole document *	1,2,8,9		TECHNICAL FIELDS SEARCHED (IPC)
X	----- DE 44 30 418 C1 (HENKEL-ECOLAB GMBH & CO OHG, 40589 DUESSELDORF, DE) 26 October 1995 (1995-10-26) * column 7, lines 3-54; figures *	1,9		D06F A47L
X	----- US 5 759 501 A (LIVINGSTON ET AL) 2 June 1998 (1998-06-02) * abstract; figures *	1,9		
The present search report has been drawn up for all claims				
Place of search		Date of completion of the search	Examiner	
Munich		14 September 2006	FALKENTOFT, C	
CATEGORY OF CITED DOCUMENTS				
X : particularly relevant if taken alone		T : theory or principle underlying the invention		
Y : particularly relevant if combined with another document of the same category		E : earlier patent document, but published on, or after the filing date		
A : technological background		D : document cited in the application		
O : non-written disclosure		L : document cited for other reasons		
P : intermediate document		& : member of the same patent family, corresponding document		

2

EPO FORM 1503 03.82 (P04C01)

ANNEX TO THE EUROPEAN SEARCH REPORT
ON EUROPEAN PATENT APPLICATION NO.

EP 06 01 1370

This annex lists the patent family members relating to the patent documents cited in the above-mentioned European search report.
The members are as contained in the European Patent Office EDP file on
The European Patent Office is in no way liable for these particulars which are merely given for the purpose of information.

14-09-2006

Patent document cited in search report		Publication date	Patent family member(s)	Publication date
DE 19617471	A1	13-11-1997	NONE	
EP 1424428	A	02-06-2004	DE 03027144 T1	10-02-2005
WO 02058528	A	01-08-2002	EP 1355561 A1	29-10-2003
DE 8018995	U1	23-10-1980	FR 2486794 A1 IT 1169261 B	22-01-1982 27-05-1987
WO 0220893	A	14-03-2002	AU 9253301 A TR 200300699 T1	22-03-2002 21-03-2005
DE 4430418	C1	26-10-1995	WO 9606969 A1 EP 0777777 A1 FI 970787 A GR 3035137 T3	07-03-1996 11-06-1997 25-02-1997 30-04-2001
US 5759501	A	02-06-1998	AU 719914 B2 AU 6281596 A BR 9608377 A CA 2232329 A1 DE 69606714 D1 DE 69606714 T2 EP 0852474 A1 ES 2142068 T3 JP 11500046 T WO 9641565 A1 ZA 9604400 A	18-05-2000 09-01-1997 05-01-1999 27-12-1996 23-03-2000 21-06-2000 15-07-1998 01-04-2000 06-01-1999 27-12-1996 09-12-1996

EPO FORM P0459

For more details about this annex : see Official Journal of the European Patent Office, No. 12/82