



(12) **EUROPEAN PATENT APPLICATION**

(43) Date of publication:  
**27.12.2006 Bulletin 2006/52**

(51) Int Cl.:  
**A61F 5/443<sup>(2006.01)</sup> A61F 5/448<sup>(2006.01)</sup>**

(21) Application number: **06120792.4**

(22) Date of filing: **16.01.2004**

(84) Designated Contracting States:  
**AT BE BG CH CY CZ DE DK EE ES FI FR GB GR HU IE IT LI LU MC NL PT RO SE SI SK TR**

• **Smith, Rory**  
**c/o Clinimed (Holdings) Limited**  
**High Wycombe Buckinghamshire HP10 9QY (GB)**

(30) Priority: **16.01.2003 GB 0300992**

(74) Representative: **Fitchett, Stuart Paul**  
**Saunders & Dolleymore**  
**European Patent Attorneys**  
**9 Rickmansworth Road**  
**Watford WD18 0JU (GB)**

(62) Document number(s) of the earlier application(s) in accordance with Art. 76 EPC:  
**04702742.0 / 1 587 467**

(71) Applicant: **CLINIMED (Holdings) LIMITED**  
**High Wycombe,**  
**Bucks HP10 9QY (GB)**

Remarks:  
This application was filed on 15 - 09 - 2006 as a divisional application to the application mentioned under INID code 62.

(72) Inventors:  
• **May, Owen**  
**c/o Clinimed (Holdings) Limited**  
**High Wycombe Buckinghamshire HP10 9QY (GB)**

(54) **A support for an ostomy bag**

(57) The present invention provides a support (1) for an ostomy bag (7), the support extending the flange of the ostomy bag to reduce the risk of leakage. The support (1) is formed of a hydrocolloid layer (2) shaped to fit

around a flange (9) of the ostomy bag. The support can be fitted to the flange at any appropriate location enabling the flange to be supported at the point at which it is prone to failing on a particular wearer.

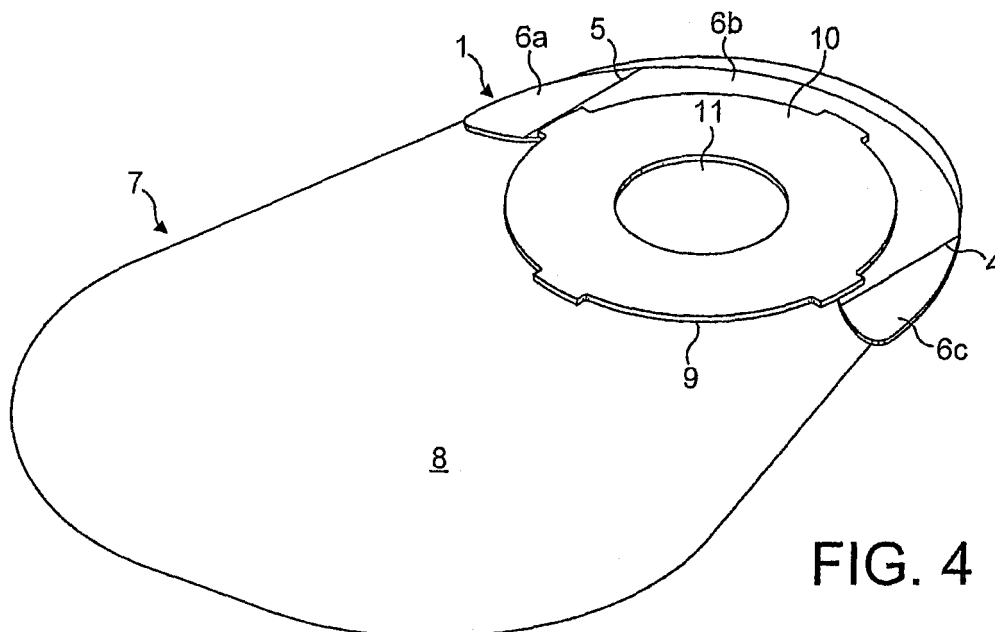

**FIG. 4**

## Description

**[0001]** The present invention relates to a support for an ostomy bag, but is also applicable to wound drainage bags. For the purposes of the present specification, including the claims, all references to ostomy bags are to be interpreted to include wound-drainage bags and wound managers.

**[0002]** The main types of ostomy bags are colostomy bags, ileostomy bags and urostomy bags. These together with wound drainage or wound manager bags have in common that they form a seal around the stoma, or wound, through which waste material is drained from the body.

**[0003]** Ostomy bags comprise a receptacle for the waste having an aperture for receiving the waste. This aperture is normally surrounded by a flange of hydrocolloid adhesive. Hydrocolloid adhesive is particularly "skin friendly" comprising approximately 20% gelatine, 20% pectin and 20% carboxymethyl cellulose in an organic matrix of polyisobutylene, which comprises the remaining 40% of the hydrocolloid adhesive.

**[0004]** The proportions of the components of the hydrocolloid adhesive may vary, but an important property of the material is that it is breathable. This is important because a particular problem with ostomy bags arises from the extended periods for which they have to be worn by a patient, normally 24 hours a day. This commonly results in maceration where the skin cannot breathe and becomes saturated.

**[0005]** The wear time of an ostomy bag is often limited by the seal about the flange failing, whereby waste fluids from the body may leak past the seal, requiring the wearer to replace the ostomy bag, thus replacing the seal formed with the bag. This leakage is not only unpleasant and potentially embarrassing for the wearer, but the waste is also corrosive to the skin when the skin is exposed to the waste for any significant period of time. This together with any maceration that may occur reduces the likelihood of any subsequent ostomy bag correctly sealing.

**[0006]** Increasing the flange size on an ostomy bag might be thought to improve the sealing ability of the flange, however it is not desired to provide an excessively large flange because this in turn will expose a larger area of skin to the possible risk of maceration and also cause problems due to the flexing of the body under the area of the flange.

**[0007]** Ostomy bags thus normally have a standard size of flange that is considered appropriate for the "average" wearer. However, all wearers are different and some find that the standard flange of an ostomy bag does not seal, or fails before the ostomy bag is full. This often arises where there are bony protuberances close to the stoma or where stomal hernias arise, often as a side effect of the skin being cut to form the stoma.

**[0008]** There are currently two products available to a wearer who suffers problems with leaking ostomy bags. The first is hydrocolloid strip, formed by extruding and

rolling hydrocolloid material. The strip is cut to length by a wearer and applied in the area where the flange seal normally fails. An alternative product used by some ostomy bag wearers is sold under the trade mark "SECU-PLAST". This comprises an annular disk of tape covered with an acrylic adhesive. This is placed behind and around the flange of an ostomy bag thereby extending the flange. However, a problem with this material is the acrylic adhesive is not as "skin friendly" as the hydrocolloid material and tends to increase skin trauma, which in turn causes problems with the subsequent fitting of further ostomy bags.

**[0009]** According to the present invention there is provided a support for an ostomy bag comprising a layer of hydrocolloid shaped to fit around and extend a portion of a flange of an ostomy bag.

**[0010]** Employing the present invention enables a wearer to fit a support in accordance with the present invention to that portion of the flange of an ostomy bag that is most prone to fail, when fitted to that particular wearer. The shaping of the layer of hydrocolloid, to fit around and extend the flange, ensures a large section of the circumference of the flange is extended whilst minimising the additional area of skin covered.

**[0011]** The invention is particularly advantageous in that it permits a standard support or range of supports to be used with one or more standard ostomy bags.

**[0012]** The hydrocolloid is self-adhesive on one side and covered by release paper arranged to be removed prior to use. This permits the hydrocolloid to be correctly positioned partially behind the flange and the release paper removed, such that the hydrocolloid support can be adhered to the flange in the correct position and, where the flange is provided with a similar release paper, the release paper of the flange then removed prior to mounting the ostomy bag upon the wearer.

**[0013]** Preferably, the hydrocolloid is semi-circular in shape, thus corresponding closely to the shape of the flange of the ostomy bag. Two hydrocolloid supports may be arranged in an opposed position about the flange, so that they extend around the complete circumference of the flange, thereby enabling the whole flange to be extended, where this is desired by a particular wearer.

**[0014]** The present invention will now be described, by way of example only, with reference to the accompanying drawings, in which like numerals are used throughout to indicate like parts, and of which:

Figure 1A is a plan view of a support in accordance with the present invention;

Figure 1B is a side elevation of the support of Figure 1A;

Figure 2 is a perspective view of the support of Figures 1A and 1B;

Figure 3 is a perspective view of the support of Figure 2, showing the release paper partially peeled back; Figure 4 illustrates an ostomy bag fitted with a support in accordance with present invention; and

Figure 5 illustrates an ostomy bag fitted with two supports in accordance with present invention.

**[0015]** Referring to Figures 1A, 1B and 2, a support for an ostomy bag in accordance with the present invention, indicated generally as 1, comprises a layer of 0.6 mm thick Hyperflex™ hydrocolloid, an EU40 25µm thick polyurethane film backing 3 and a release paper divided by two cuts 4 and 5 into three sections 6a, 6b and 6c, the release paper being standard sterling coated paper. The properties of the hydrocolloid material 2 and polyurethane film 3 are such that the support 1 is breathable when the release paper 6a, 6b, 6c is removed.

**[0016]** Figure 3 illustrates how the support 1 can be slightly flexed in the region of the slit 4 permitting the release paper to be held and peeled back. The release paper can similarly be removed starting at the slit 5.

**[0017]** Referring to Figure 4, there is illustrated a standard ostomy bag, illustrated generally as 7, comprising a receptacle portion 8, for receiving waste, and a flange 9. The flange 9 is formed of hydrocolloid material and has a release paper on its upper surface 10. In use the release paper is removed and the flange 9 centred on a stoma or wound of the wearer, such that fluid drains from the stoma or wound into the receptacle 8, via aperture 11 in the flange 9.

**[0018]** The support 1 of the present invention is placed in any desired position about the flange 9, and then slid partly behind the flange with the release paper 6a, 6b, 6c uppermost, as shown. In this position, starting at one of the slits 4 or 5, the release papers are peeled from the support 1 and the support adhered to the flange 9. Then the release paper (not shown) of the flange 9 is removed from the uppermost surface 10 and the flange 9 and support 1 simultaneously adhered to the wearer.

**[0019]** As shown in Figure 5, a number of supports in accordance with the invention may be used on an ostomy bag, either to completely surround the flange as shown in Figure 5, to further extend the flange in a particular direction, that is to say further than it could be extended by use of a single support, or a number of supports may be built up in depth so as to account for any depression in the surface of the wearer adjacent a stoma. Although not illustrated, it is possible that supports of different sizes may also be provided.

**[0020]** The present invention has been illustrated by way of example only and further embodiments may be apparent within the scope of the appended claims.

## Claims

1. A support (1) for an ostomy bag (7) comprising a layer of hydrocolloid (2) shaped to fit around and extend a portion of a flange (9) of an ostomy bag, wherein the layer of hydrocolloid (2) is self-adhesive on one side, the said self-adhesive side of the hydrocolloid layer is covered by a release paper (6)

arranged to be removed prior to use, **characterised in that** the release paper (6) is divided by two cuts (4, 5) into three so that it has two end sections (6a, 6c) and a middle section (6b).

2. A support (1) as claimed in claim 1 wherein the hydrocolloid layer (2) is semicircular.
3. A support (1) as claimed in any preceding claim, arranged to cooperate with a similar support (1) to form a collar extending around the complete circumference of the flange (9).

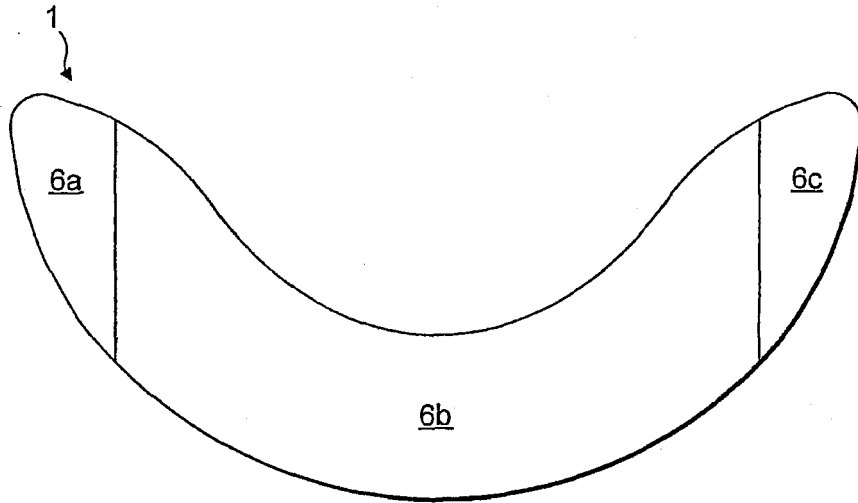

FIG. 1A

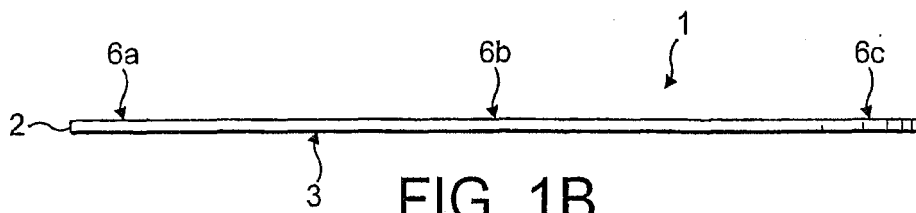

FIG. 1B

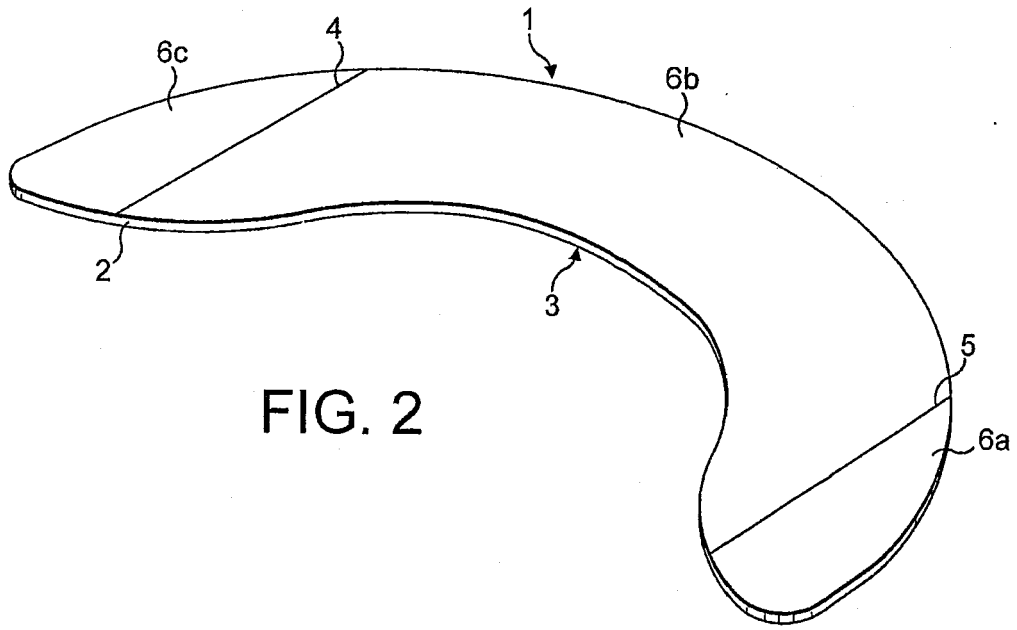

FIG. 2

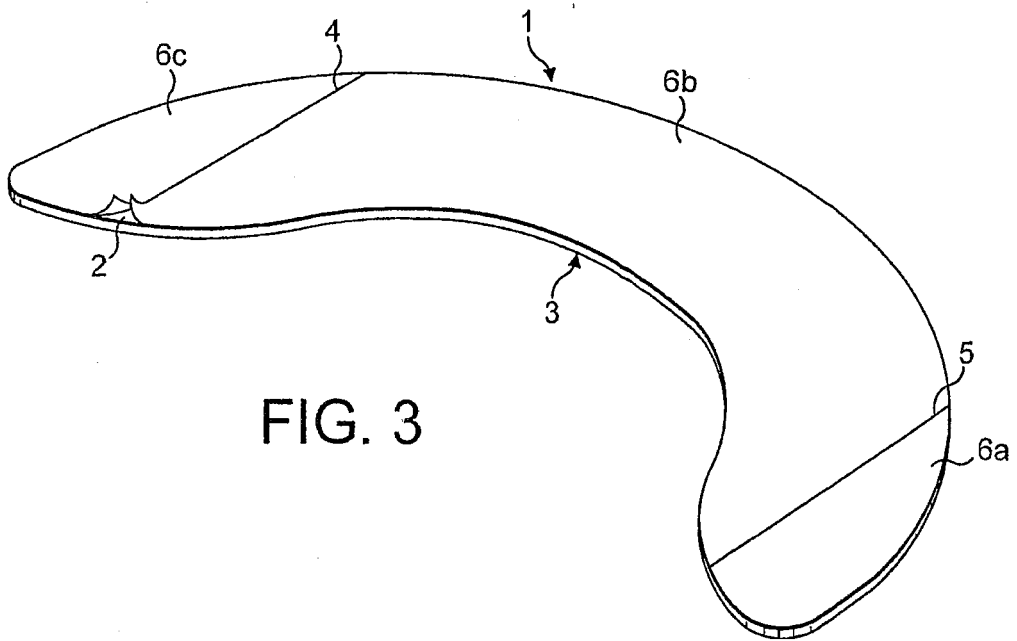
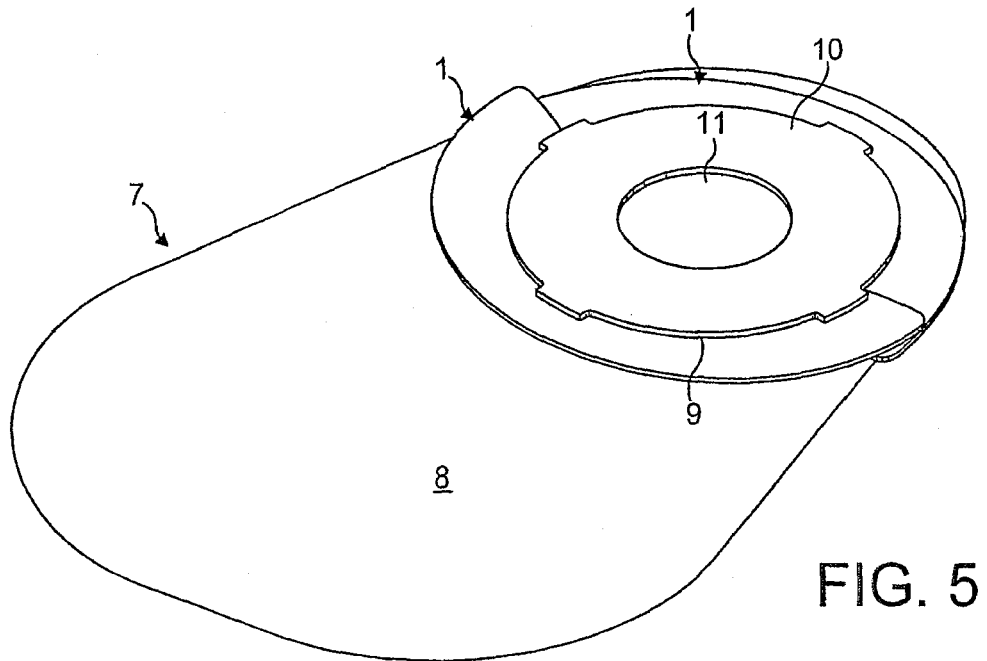
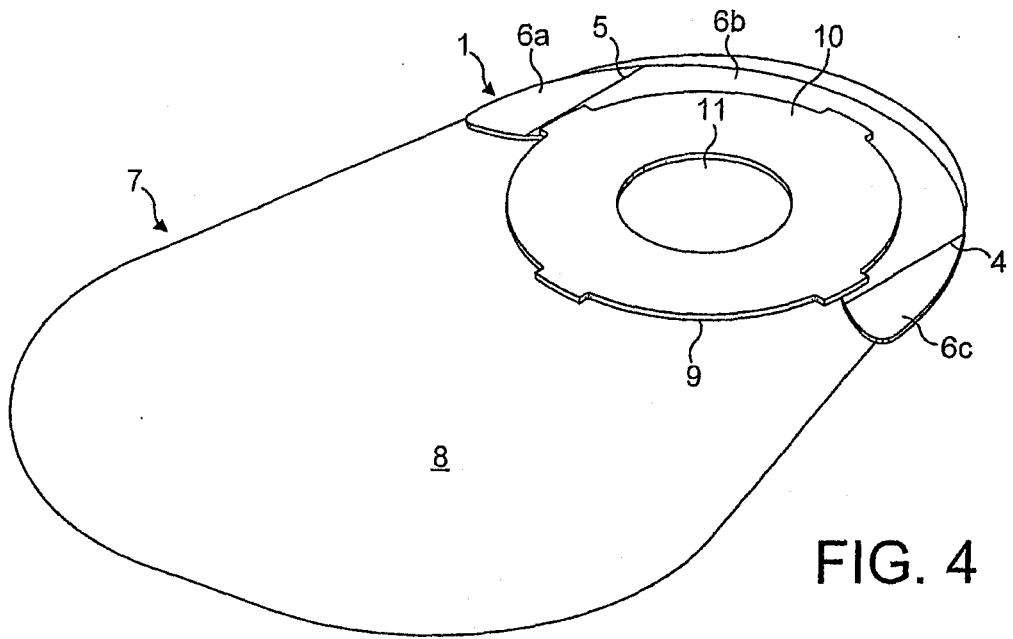

FIG. 3





European Patent Office

**PARTIAL EUROPEAN SEARCH REPORT**

Application Number

which under Rule 45 of the European Patent Convention EP 06 12 0792 shall be considered, for the purposes of subsequent proceedings, as the European search report

DOCUMENTS CONSIDERED TO BE RELEVANT			
Category	Citation of document with indication, where appropriate, of relevant passages	Relevant to claim	CLASSIFICATION OF THE APPLICATION (IPC)
X	US 3 039 464 A (ESPERANZA GALINDO) 19 June 1962 (1962-06-19) * the whole document *	1-3	INV. A61F5/443 A61F5/448
X	US 2003/004477 A1 (GOTHJAELPSEN LAILA BUSK ET AL) 2 January 2003 (2003-01-02) * paragraphs [0077] - [0081]; figure 9 *	1-3	
X	WO 02/05735 A (HOOD WILLIAM) 24 January 2002 (2002-01-24) * page 12, line 4 - page 13, line 15 *	1-3	
A	US 5 384 174 A (WARD WILLIAM J [GB] ET AL) 24 January 1995 (1995-01-24) * column 5, line 67 - column 6, line 10; figure 2 *	1-3	
A	EP 0 793 951 A1 (SQUIBB BRISTOL MYERS CO [US]) 10 September 1997 (1997-09-10) * column 6, lines 47-56 * * column 7, lines 22-48; figure 4 *	1-3	
A	GB 2 152 387 A (HOLLISTER INC) 7 August 1985 (1985-08-07) * page 2, lines 88-117; figures 1,9 *	1-3	TECHNICAL FIELDS SEARCHED (IPC) A61F
<b>INCOMPLETE SEARCH</b>			
<p>The Search Division considers that the present application, or one or more of its claims, does/do not comply with the EPC to such an extent that a meaningful search into the state of the art cannot be carried out, or can only be carried out partially, for these claims.</p> <p>Claims searched completely :</p> <p>Claims searched incompletely :</p> <p>Claims not searched :</p> <p>Reason for the limitation of the search: see sheet C</p>			
Place of search Munich		Date of completion of the search 20 November 2006	Examiner Krassow, Heiko
CATEGORY OF CITED DOCUMENTS X : particularly relevant if taken alone Y : particularly relevant if combined with another document of the same category A : technological background O : non-written disclosure P : intermediate document		T : theory or principle underlying the invention E : earlier patent document, but published on, or after the filing date D : document cited in the application L : document cited for other reasons ..... & : member of the same patent family, corresponding document	

4

EPO FORM 1503 03.02 (P04C07)



Claim(s) not searched:

6

Reason for the limitation of the search:

Claim 6 seeks to define the invention by reference to the figures, and without defining any technical features (Article 6.2 PCT). The resulting lack of clarity is such that it is impossible to exactly determine the scope for which protection is sought rendering a meaningful search impossible.



ANNEX TO THE EUROPEAN SEARCH REPORT  
ON EUROPEAN PATENT APPLICATION NO.

EP 06 12 0792

This annex lists the patent family members relating to the patent documents cited in the above-mentioned European search report. The members are as contained in the European Patent Office EDP file on The European Patent Office is in no way liable for these particulars which are merely given for the purpose of information.

20-11-2006

Patent document cited in search report	Publication date	Patent family member(s)	Publication date
US 3039464	A	19-06-1962	NONE
US 2003004477	A1	02-01-2003	AT 320779 T 15-04-2006 AU 721675 B2 13-07-2000 AU 4616397 A 15-05-1998 CA 2269575 A1 30-04-1998 CN 1233945 A 03-11-1999 WO 9817212 A1 30-04-1998 EP 0998247 A1 10-05-2000 ES 2260801 T3 01-11-2006 JP 2001502570 T 27-02-2001 NO 991905 A 22-06-1999
WO 0205735	A	24-01-2002	AU 7638101 A 30-01-2002 GB 2381200 A 30-04-2003
US 5384174	A	24-01-1995	NONE
EP 0793951	A1	10-09-1997	AT 264090 T 15-04-2004 AT 218312 T 15-06-2002 AU 705091 B2 13-05-1999 AU 1494497 A 04-09-1997 CA 2198515 A1 29-08-1997 DE 69712946 D1 11-07-2002 DE 69712946 T2 23-01-2003 DE 69728699 D1 19-05-2004 DE 69728699 T2 23-09-2004 DK 793951 T3 09-09-2002 ES 2215837 T3 16-10-2004 ES 2176606 T3 01-12-2002 JP 9313517 A 09-12-1997 NZ 314147 A 26-08-1998 US 5722965 A 03-03-1998 ZA 9701614 A 25-08-1998
GB 2152387	A	07-08-1985	AU 559535 B2 12-03-1987 AU 1199883 A 22-09-1983 CA 1190823 A1 23-07-1985 DE 3309083 A1 22-09-1983 DK 102883 A 17-09-1983 ES 279833 U 16-11-1984 FR 2523435 A1 23-09-1983 GB 2116849 A 05-10-1983 HK 52087 A 10-07-1987 HK 83087 A 13-11-1987 IE 53994 B1 10-05-1989

EPO FORM P0459

For more details about this annex : see Official Journal of the European Patent Office, No. 12/82

**ANNEX TO THE EUROPEAN SEARCH REPORT  
ON EUROPEAN PATENT APPLICATION NO.**

EP 06 12 0792

This annex lists the patent family members relating to the patent documents cited in the above-mentioned European search report. The members are as contained in the European Patent Office EDP file on  
The European Patent Office is in no way liable for these particulars which are merely given for the purpose of information.

20-11-2006

Patent document cited in search report	Publication date	Patent family member(s)	Publication date
GB 2152387	A	JP 1500596 C	28-06-1989
		JP 58165843 A	30-09-1983
		JP 63052900 B	20-10-1988
		SE 454238 B	18-04-1988
		SE 8301349 A	17-09-1983
		US 4445898 A	01-05-1984
-----			

EPO FORM P0459

For more details about this annex : see Official Journal of the European Patent Office, No. 12/82