



(11) **EP 1 736 616 B1**

(12) **EUROPEAN PATENT SPECIFICATION**

(45) Date of publication and mention of the grant of the patent:
29.10.2008 Bulletin 2008/44

(51) Int Cl.:
E04H 6/10 (2006.01)

(21) Application number: **06115042.1**

(22) Date of filing: **06.06.2006**

(54) **Demountable modular parking lot with at least one storey in addition to the ground floor**

Abmontierbarer Abstellplatz mit mindestens einem Geschoß zusätzlich zum Erdgeschoß

Parcage démontable avec au moins un étage en plus du rez-de-chaussée

(84) Designated Contracting States:
AT BE BG CH CY CZ DE DK EE ES FI FR GB GR HU IE IS IT LI LT LU LV MC NL PL PT RO SE SI SK TR
Designated Extension States:
BA HR MK RS

(72) Inventor: **Mussini, Daniele**
42100 Reggio Emilia (IT)

(74) Representative: **Ripamonti, Enrico et al**
Giambrocono & C. S.p.A.
Via Rosolino Pilo, 19/b
20129 Milano (IT)

(30) Priority: **23.06.2005 IT MI20051192**

(43) Date of publication of application:
27.12.2006 Bulletin 2006/52

(56) References cited:
EP-A- 0 618 336 EP-A1- 0 364 414
EP-B1- 1 165 909 GB-A- 2 229 203

(73) Proprietor: **Mussini, Daniele**
42100 Reggio Emilia (IT)

EP 1 736 616 B1

Note: Within nine months of the publication of the mention of the grant of the European patent in the European Patent Bulletin, any person may give notice to the European Patent Office of opposition to that patent, in accordance with the Implementing Regulations. Notice of opposition shall not be deemed to have been filed until the opposition fee has been paid. (Art. 99(1) European Patent Convention).

Description

[0001] The present invention relates to a demountable and remountable modular parking lot for motor vehicles, composed of at least one upper storey in addition to the ground floor.

[0002] Various types of structures for modular parking lots are known to the expert of the art, which enable the number of vehicles parkable on a determined area to be doubled. Many of these structures are of fixed type, either of steel or of reinforced concrete, however more recently some have been of demountable and remountable construction.

[0003] EP 0 364 414 B1 describes a structure of this latter type, suitable for constructing temporary parking lots consisting of a first transit and parking floor, accessible by one or more ramps, and a ground floor (covered by the first floor) also usable for transit and parking. The relative structure is obtained by assembling a determined number (depending on parking requirements) of modular structural units, each of which comprises: a square or rectangular floor slab constructed of ribbed sheet steel, completed upperly by a filling and finishing material to provide a walking path; four steel beams, one for each edge of the floor slab; four steel junction elements at the corners of the floor slab; four vertical steel support elements below each of the junction elements; and four steel bases below each vertical support element.

[0004] Structure bracing rods are also provided, the ends of which are connected to said junction elements and bases.

[0005] The vertical support elements are subjected only to axial load for the reasons given hereinafter. Means are also provided to adjust the length of the vertical support elements. The bases each comprise a baseplate from which there upwardly extends a coaxial cylindrical collar rigidly fixed to the baseplate. A first hinge element, in the form of a spherical cap, rests on the baseplate within the cylindrical collar, with its convex side facing upwards. The vertical support element comprises an externally threaded lower cylindrical pin of diameter less than the inner diameter of said cylindrical collar, in order to be inserted fairly loosely into this latter. At its lower end the threaded cylindrical pin presents a second hinge element of spherical cup shape, complementary to said first hinge element, the concave side of the second hinge element facing downwards. An internally threaded sleeve is screwed onto the cylindrical pin and can be inserted into and locked in the lower end of the upper part of the vertical support element, which is in the form of a tubular element.

[0006] A true hinge therefore exists at the lower end of each vertical support element, so that this latter is subjected in practice only to axial load. It should however be noted that the cross-section through the vertical support elements cannot have less than determined dimensions and thicknesses, both for constructional reasons and to prevent any instability phenomena appearing locally and

throughout the entire vertical support element. Hence the benefit of vertical support elements subjected only to axial load is not in the end substantial, especially considering that the work required to form a vertical support element of the aforesaid type is decidedly demanding and costly.

[0007] The junction element of the modular structural unit represented in the figures of EP 0 364 414 B1 comprises: a first tubular part insertable coaxially a certain distance into the free upper end of the upper tubular part of the relative vertical support element, and externally presenting angularly equidistant plates for connection to said bracing rods; a horizontal plate for supporting said edge beams fixed to the outer end of the first tubular part; and a second tubular part above the first tubular part and in one piece and coaxial therewith. The second tubular part presents four vertical plates for connection to said edge beams, these plates being angularly equidistant and slightly offset from the axial vertical plane through the relative edge beam, this plane also passing through the axis of the relative vertical support element.

[0008] EP 1 165 909 B1 describes a deck for demountable modular parking lots of the type described in EP 0 364 414 B1. Specifically, the deck of the modular structural unit comprises a floor slab, which is provided with rain water collection and disposal channels and is formed of panels of ribbed sheet steel cooperating with an overlying casting of suitably reinforced concrete.

[0009] Demountable modular parking lots in accordance with the teachings of EP 1 165 909 B1 and EP 0 364 414 B1 effectively exist. However, in addition to the four perimetral steel beams provided in EP 0 364 414 B1, they also always comprise a secondary steel beam which rests between the centres of two parallel edge beams (so that in this version, the structural unit uses five beams). This enables the floor slab span to be significantly reduced.

[0010] From the foregoing it is evident that the aforesaid modular structural unit is fairly complicated, in that some of its structural elements (in particularly the vertical support elements and the bases) are more similar to pieces of machinery than to the structural steelwork for a parking lot, with the constructional difficulties and costs that this involves.

[0011] An object of the present invention is therefore to provide a demountable modular parking lot, obtained by assembling modular structural units which are decidedly more simple than that of EP 0 364 414 B1.

[0012] Another object is to provide a demountable modular parking lot which can have more than one upper storey, each storey being formed with the same type of modular structural unit.

[0013] These objects are attained by the demountable modular parking lot of the present invention, comprising in addition to one or more access ramps, a determined number of modular structural units and adequate bracing elements, each modular structural unit comprising: a square or rectangular deck including steel beams which

carry a single floor slab or several side by side floor slabs, the floor slab or floor slabs being formed using sheet steel; four junction elements, also of steel, on which the deck rests at its four corners; four steel vertical support elements, at the top of which a junction element is provided; and four steel bases, each base comprising a baseplate from which a tubular collar extends coaxially upwards to receive fairly loosely the lower end of the relative vertical support element; characterised in that:

the deck comprises only two steel edge beams parallel to each other;
each vertical support element is formed in one piece of fixed length, the lower end of which is directly insertable loosely into the tubular collar of the relative base.

[0014] As will be immediately apparent, the fact of having essentially eliminated said base hinge composed of mating spherical caps and of no longer having a vertical support element formed from two different parts (the lower threaded pin and the upper tubular element joined together by a screw and lead nut coupling), but instead in one piece of fixed length, considerably simplifies the structure, its construction and its assembly, to finally obtain a significant cost saving. It should however be noted that the expression "one piece of fixed length" does not mean that the vertical support element cannot, in turn, be composed of several elements fixed rigidly together (it can for example be a lattice or cross-stiffened upright).

[0015] The fact that the vertical support elements are in one piece of fixed length does not mean that it is not possible to vary within certain limits the distance between the base and the overlying deck, this being achieved extremely simply by inserting a spacer element into the tubular collar of the relative base, this spacer element directly supporting the lower end of the vertical support element inserted into the tube piece, this latter evidently having to be of adequate height.

[0016] Preferably each junction element comprises a first plate, which fixed similarly to a capital to the top of the vertical support element, the first plate carrying by means of threaded bars and relative nuts and locking nuts an overlying second plate, parallel to and spaced from the first, one end of the relative edge beam resting on and being removably fixed to the second plate.

[0017] For the same reasons (as already stated) for which in existing demountable modular parking lots in accordance with EP 0 364 414 B1 the modular structural unit always comprises an intermediate secondary beam in addition to the four edge beams (making a total of five beams), the structural units of the parking lot of the present invention can also comprise an intermediate secondary beam or even two parallel intermediate secondary beams (making a total of three and four beams respectively, a number in any event less than five). In the particular case of two parallel secondary beams carried

by the edge beams, these conveniently divide the deck of a modular structural unit into three bays with the central bay being double the span of the two side bays. In this case it can be convenient to provide floor slabs which are all equal (to be known as typical floor slabs) and have a span equal to the distance between two secondary beams, with the central floor slab resting on the two secondary beams and the lateral floor slabs resting at one end on one of the two secondary beams of the modular structural unit concerned and the other end on the nearer secondary beam of the adjacent modular structural unit. As will be apparent, such an arrangement can be used for the "non-lateral" structural units of the parking lot according to the invention, given that the modular structural units forming two parallel sides of the parking lot (known hereinafter as "lateral" structural units) require an additional secondary beam (the lateral structural units hence have five beams) disposed on the outer edge of the relative deck area, a relative floor slab with a span one half the span of the typical floor slab also having to be provided. It is apparent that the "non-lateral" structural units are normally of a considerably greater number than the "lateral" floor slabs, so that this arrangement is in any event convenient.

[0018] It should also be noted that the demountable modular parking lot of the present invention can if required have two, three or more upper storeys. To achieve this result, it is sufficient to simply superpose a number of parking lots having one upper storey, provided that the vertical support elements of each storey are dimensioned for the predicted loads deriving from the overlying storeys. In particular, if junction elements of the aforesaid type are used, threaded bars need simply to be provided having a length sufficient to also secure the base of the overlying storey.

[0019] The invention will be more apparent from the following description of a demountable modular parking lot of the invention given by way of example. In this description reference is made to the accompanying drawings, in which:

Figure 1 is a perspective view from below showing a modular structural unit, the deck of which comprises a single floor slab resting directly on the two edge beams;

Figure 2 is a perspective view thereof from above; Figure 3 is a perspective view from below showing a variant of the structural unit of Figures 1 and 2, of the "non-lateral" type (in the aforesaid sense); Figure 4 is a perspective view thereof from below; Figure 5 is a reduced perspective view from above showing a "lateral" modular structural unit usable with that of Figures 2 and 3;

Figure 6 is an elevation of a typical base suitable for the modular structural units both of Figures 1 and 2 and of Figures 3, 4 and 5;

Figure 7 is a plan view thereof from above;

Figure 8 is a perspective view thereof;

Figure 9 shows the base of Figure 7 to which a means for protection against impacts has been added; Figure 10 is a perspective view thereof; Figure 11 is a front elevation of a vertical support element for the modular structural units; Figure 12 is a side elevation thereof; Figure 13 is a plan view thereof from below; Figure 14 is a vertical section showing a detail of a modular parking lot of the invention, the section being taken at an intermediate vertical support element, perpendicular to one of the two edge beams; Figure 15 is a vertical section showing another detail of the same parking lot, the section being taken transversely to a secondary beam; Figure 16 is a vertical section showing a further detail of the same parking lot, the section being taken perpendicular to the more outer edge beam of a "lateral" modular structural unit, at an intermediate point of said beam.

[0020] As can be seen from Figures 1 and 2, the modular structural unit shown therein, indicated overall by 10, comprises a deck consisting essentially of a floor slab 16 and two parallel steel edge beams 12, which in this specific case are of I cross-section (their cross-section can however be of different shape). The floor slab 16 is formed in this specific case from ribbed sheet steel, cooperating with an overlying reinforced concrete casting (not shown in the figures for simplicity). The sheet steel could however be non-ribbed (i.e. smooth), and not be provided with a cooperating layer, in the sense that it could have merely an upper covering or hood, not cooperating with a sheet steel, to form the treading/transit surface (hence without using cooperating reinforced concrete).

[0021] In the variant shown in Figures 3, 4 and 5, the modular structural unit 10NL and 10L has a deck provided with two additional secondary steel beams 14, of I cross-section. These latter are spaced apart by a distance equal to one half their distance from the adjacent vertical support elements indicated by 18. Two typical floor slabs (identical, of span L), indicated overall by the reference numerals 16A and 16B, rest on the secondary beams 14. The typical floor slabs 16A and 16B can be of the various types described above with reference to the floor slab 16 of Figures 1 and 2, and in particular can comprise a ribbed steel sheet cooperating with an overlying reinforced concrete casting.

[0022] It should be noted that the floor slab 16B rests at one end on one of the two secondary beams 14 of the structural unit 10NL, while its other end rests on the nearer secondary beam of an adjacent modular unit (having two vertical support elements in common with the first). As stated, the modular structural unit 10NL of Figures 3 and 4 is of "non-lateral" type, normally used to form most of the parking lot, whereas the structural units which form two of the parallel edges of this latter (i.e. the "lateral" structural units, of which one is shown in Figure 5 and

indicated by 10N) differ from the unit 10NL merely by the fact that in addition to the typical floor slabs 16A and 16B they must also comprise a third lateral floor slab 16L, formed in practice as these latter but with one half the span. A third secondary edge beam 14L must also be provided in the modular structural units to support the outer edge of the floor slab 16L.

[0023] From Figures 1, 2, 3, 4, 5, 14 and 16, it can be seen that the two edge beams 12 rest on those which have previously been called second steel plates, indicated in said figures by 20, supported via threaded bars 22 and relative nuts 24 and locking nuts 26 by those which have been previously called first steel plates, welded to the top of the vertical support elements 18 (in this specific case consisting of two tubular columns having a cross-section which is square, or in other embodiments, rectangular or H-shaped) and which are indicated by 28 in said figures. The unit formed by the first steel plates 28, second steel plates 20 and threaded bars 22 with the relative nuts 24 and locking nuts 26 is that which has been previously called the junction element, and is indicated overall by 30. As can be seen from Figures 11-14, the first plate 28 is stiffened by lower angle plates 32 welded to it and to the tubular column 18, in this specific case of square cross-section. As the plates 20 and 28 of the junction elements 30 present a central circular hole (indicated by 37 and 35 respectively), a relative downpipe 34 (Figures 14 and 16) can be conveniently passed through the tubular columns 18, to then emerge from the column 18 at a suitable height as not to interfere with the base 36 and relative accessories (described hereinafter). The base 36 is best seen in Figures 6-8 and comprises a baseplate 38 on which a collar 40 is centrally welded, formed from a piece of square tube, which enables the lower end of the relative vertical support element 18 to be received fairly slackly (Figure 14), such that said lower end rests simply and directly on the baseplate 38. Angle plates 42 welded to the baseplate 38 and to the collar 40 make the assembly rigid. Suitable holes can be provided in the angle plates 42 and 32 for connecting bracing elements to them, in particular the rods 44 of Figures 1-4. The baseplate 38 presents four through holes 48 for fixing to the ground by anchoring bolts. In the case of a parking lot with more than one upper storey, the holes 48 can be used to anchor the base 36 of one storey to the underlying storey, by using the threaded bars 22 of the underlying junction element 30.

[0024] By loosely inserting the lower end of a column 18 directly into the collar 40, there is no need to provide a perfectly horizontal support surface for the baseplate 38. In this respect, even an inclination (obviously not excessive) of said support surface still enables the columns 18 to be maintained vertical (by virtue of the said loose engagement). The fact that this situation may lead to only partial and eccentric support of the lower end of the column 18 on the baseplate 38 does not cause problems, seeing that (as already stated) the columns 18 are appropriately dimensioned for combined compressive and

bending stress.

[0025] As can be seen from Figures 6-8, the base 36 is provided with an annular element 46 lying in a plane parallel to the baseplate 38 and welded to the angle plates 42, and against which a vehicle's wheels collide before they laterally strike the column 18. This can happen during parking, hence the annular element 46 serves to prevent impact against the columns 18. As can be seen from Figures 9 and 10, the base 36 can be provided with a protection means 50 for the columns 18 which, notwithstanding the presence of the annular element 46, may be struck (for example frontwards or rearwards) by vehicles. The protection means 50 has a roughly C shaped cross-section (Figure 9), to substantially surround one half of the perimeter of the bottom of a column 18, and is fixable to the base 36 by a single bolt, being provided with two parallel lugs 52 which, when the protection means 50 is in position, lie straddling one of the angle plates 42. The advantage of this arrangement is that if the danger of impact exists on only one side (as in the case of the edge columns), the protection means 50 is provided only on the side concerned (as in Figures 9 and 10), whereas if the column 18 can be struck on both sides these sides are protected by two equal protection means disposed symmetrically. It will be noted that the base shown in Figures 9 and 10 is otherwise identical to that of Figures 6-8.

[0026] As already stated, the height of the column 18 can be varied, within certain limits, by simply interposing a spacer element (not shown for simplicity) between the baseplate 38 and the lower end of a relative column 18, so that by providing a spacer element of suitable thickness the distance between the base 36 and the second plate 20 can be varied (within determined limits). It should also be noted that this distance can be more finely adjusted by the threaded bars 22 and relative nuts 24 and locking nuts 26 of the junction elements 30. The columns 18 can have cross-sections other than square (for example rectangular, polygonal or H shape).

[0027] It should also be noted that the last storey (if there is only one upper storey, this will be the last) of the parking lot of the present invention can be covered by conventional covering (for example a simple roof), which would be lighter than the floor of the parking lot as it has only to support weather-induced loads. However there is nothing to prevent the covering from being obtained by utilizing an additional floor obtained by using the modular structural units of the parking lot of the present invention.

[0028] Figures 14 and 15 show how the floor slabs 16A and 16B are formed in this specific case with ribbed sheet steel completed with an upper reinforced concrete casting to obtain a treading/transit/drivable floor. If there is no overlying roof, the relative deck is provided with secondary channels 54 (Figures 4 and 5) between the floor slabs 16A and 16B, exactly above the secondary beams 14, for removing rain water, their two ends discharging into main channels located above the edge beams 12.

Specifically, Figure 14 shows in cross-section a main channel 56 if the floor slabs 16 lie on both its sides, whereas Figure 16 shows a main channel 56L if the relative main beam 12 is the most outer edge beam. The channels are closed upperly by conventional grilles 62.

[0029] The same figure shows how a parapet 65 similar to that of which a portion is shown in Figures 1-5 can be fixed to the edge beam 12.

[0030] Figure 15, in addition to showing how the joint can be made between a secondary beam 14 and a main beam 12, also shows how an expansion joint can be obtained between two floor slabs 16A and 16B in the position in which otherwise there would be a secondary channel 54, the joint gap being filled lowerly with a polystyrene layer 58 and upperly with an impermeable material 60.

Claims

1. A demountable and remountable modular parking lot for motor vehicles, composed of at least one upper storey in addition to the ground floor and comprising, in addition to one or more access ramps to the upper storeys, a determined number of modular structural units (10; 10NL, 10L) and adequate bracing elements (43, 44), each modular structural unit (10; 10NL, 10L) comprising: a square or rectangular deck including steel beams (12, 14, 14L) which carry a single floor slab (16) or several side by side floor slabs (16A, 16B, 16L), the floor slab (16) or floor slabs (16A, 16B, 16L) being formed using sheet steel; four junction elements (30), also of steel, on which the deck rests at its four corners; four steel vertical support elements (18) at the top of which a junction element (30) is provided; and four steel bases (36), each base (36) comprising a baseplate (38) from which a tubular collar (40) extends coaxially upwards to receive fairly loosely the lower end of the relative vertical support element (18);

characterised in that:

the deck comprises only two steel edge beams (12) parallel to each other; each vertical support element (18) is formed in one piece of fixed length, the lower end of which is directly insertable loosely into the tubular collar (40) of the relative base (36).

2. A demountable and remountable modular parking lot as claimed in claim 1, wherein a spacer element is insertable into the interior of the tubular collar (40) to vary the distance between the base (36) and the junction element (30).
3. A demountable and remountable modular parking lot as claimed in claim 1, wherein the vertical support elements (18) are obtained from tubular profile bars.

4. A demountable and remountable modular parking lot as claimed in claim 3, wherein the tubular profile bars from which the vertical support elements are obtained are of square, rectangular or H cross-section.
5. A demountable and remountable modular parking lot as claimed in claim 1, wherein each junction element (30) comprises a first fixed plate (28) similar to a capital at the top of the vertical support element (18), the first plate (28) carrying by means of threaded bars (22) and relative nuts (24) and locking nuts (26) an overlying second plate (20), parallel to and spaced from the first (28), one end of the relative edge beam (12) resting on and being removably fixed to the second plate.
6. A demountable and remountable modular parking lot as claimed in claim 1, wherein one or two intermediate secondary beams (14) are provided in each modular structural unit (10; 10NL, 10L).
7. A demountable and remountable modular parking lot as claimed in claim 6, wherein the intermediate secondary beams (14) are two in number and divide the deck of a modular structural unit (10: 10NL, 10L) into three bays with the span (L) of the central bay (16A) being double the span (U2) of the two side bays.
8. A demountable and remountable modular parking lot as claimed in claim 1, wherein the sheet steel of the floor slabs (16; 16A, 16B, 16C) is ribbed.
9. A demountable and remountable modular parking lot as claimed in claim 1, wherein the floor slabs (16; 16A, 16B, 16C) are of mixed type, the sheet steel cooperating with an overlying layer of reinforced concrete.
10. A demountable and remountable modular parking lot as claimed in claim 1, wherein the sheet steel of the floor slabs (16; 16A, 16B, 16C) is covered upperly with at least one layer of treadable/transit material which does not statically cooperate with the sheet steel.
11. A demountable and remountable modular parking lot as claimed in claim 7, wherein all those structural units (10NL) which do not form two of the parallel sides of the parking lot, the floor slabs (16A, 16B) are all identical and have a span (L) equal to the distance between the axes of two intermediate secondary beams (14).
12. A demountable and remountable modular parking lot as claimed in claim 1, wherein a third secondary edge beam (14L) is provided in all those modular structural units (10L) which form two of the parallel sides of the parking lot, the most outer floor slab (16L) resting on this later beam (14L) and on the adjacent secondary beam (14).
13. A demountable and remountable modular parking lot as claimed in claim 1, wherein the bases (36) present stiffening ribs (42) to which an annular element (46) is fixed lying in a plane parallel to the base-plate (38), and against which (46) the wheels of vehicles strike before these latter strike laterally against the vertical support element (18).
14. A demountable and remountable modular parking lot as claimed in claim 1, wherein an element (50) can be applied to the bases (36) to give protection against collisions with at least part of the perimeter of the lower part of the relative vertical support element (18).
15. A demountable and remountable modular parking lot as claimed in claims 2 and 14, wherein the protection element (50) is of roughly C-shaped cross-section and substantially surrounds one half of the perimeter of the lower part of a vertical support element (18).
16. A demountable and remountable modular parking lot as claimed in claim 1, wherein the last storey of the parking lot is covered by a conventional covering.
17. A demountable and remountable modular parking lot as claimed in claim 1, wherein if no covering is provided for the last storey of the parking lot, this latter presents rain water removal channels disposed between the individual floor slabs (16; 16A, 16B, 16L) and discharging into relative downpipes (34).
18. A demountable and remountable modular parking lot as claimed in claims 2, 3, 5 and 15, wherein the downpipes (34) are located within the tubular vertical support elements (18), the first plate (28) and the second plate (20) of the junction element (30) presenting a central hole (37, 35) for passage of the downpipe (34).

Patentansprüche

1. Abmontierbarer und wiedermontierbarer modularer Parkplatz für Motorfahrzeuge, welcher aus mindestens einer oberen Etage zusätzlich zu dem Erdgeschoss gebildet ist und zusätzlich zu einer oder mehreren Zugangsrampen zu den oberen Etagen eine vorbestimmte Anzahl von modularen Struktureinheiten (10; 10NL, 10L) und angemessene Verstrebungselemente (43, 44) umfasst, wobei jede modu-

lare Struktureinheit (10; 10NL, 10L) umfasst: ein quadratisches oder rechteckiges Deck, welches Stahlträger (12, 14, 14L) aufweist, welche eine einzelne Bodenplatte (16) oder mehrere Bodenplatten (16A, 16B, 16L) nebeneinander tragen, wobei die Bodenplatte (16) oder die Bodenplatten (16A, 16B, 16L) unter Verwendung eines Stahlblechs ausgebildet sind; vier Verbindungselemente (30), auch aus Stahl, auf welchen das Deck an seinen vier Ecken liegt; vier vertikale Stahlhalteelemente (18), an deren Oberseite ein Verbindungselement (30) vorgesehen ist; und vier Stahlsockel (36), wobei jeder Sockel (36) eine Sockelplatte (38) umfasst, von welcher sich ein röhrenförmiger Bund (40) koaxial nach oben erstreckt, um das untere Ende des jeweiligen vertikalen Halteelements (18) ziemlich locker aufzunehmen;

dadurch gekennzeichnet, dass:

- das Deck nur zwei Stahlrandträger (12) parallel zueinander umfasst; wobei jedes vertikale Halteelement (18) in einem Stück von fester Länge ausgebildet ist, wobei das untere Ende davon direkt locker in den röhrenförmigen Bund (40) des jeweiligen Sockels (36) einsetzbar ist.
2. Abmontierbarer und wiedermontierbarer modularer Parkplatz nach Anspruch 1, wobei ein Abstandselement in den Innenraum des röhrenförmigen Bunds (40) einsetzbar ist, um den Abstand zwischen dem Sockel (36) und dem Verbindungselement (30) zu verändern.
 3. Abmontierbarer und wiedermontierbarer modularer Parkplatz nach Anspruch 1, wobei die vertikalen Halteelemente (18) aus röhrenförmigen Profilstangen gewonnen werden.
 4. Abmontierbarer und wiedermontierbarer modularer Parkplatz nach Anspruch 3, wobei die röhrenförmigen Profilstangen, aus welchen die vertikalen Halteelemente gewonnen werden, einen quadratischen, einen rechteckigen oder einen H-Querschnitt aufweisen.
 5. Abmontierbarer und wiedermontierbarer modularer Parkplatz nach Anspruch 1, wobei jedes Verbindungselement (30) eine fest angeordnete erste Platte (28) ähnlich einem Haupt an der Oberseite des vertikalen Halteelements (18) umfasst, wobei die erste Platte (28) mittels Gewindestangen (22) und jeweiligen Muttern (24) und Verriegelungsmuttern (26) eine darüberliegende zweite Platte (20) parallel und beabstandet von der ersten (28) trägt, wobei ein Ende des jeweiligen Randträgers (12) auf der zweiten Platte liegt und damit entferntbar befestigt ist.
 6. Abmontierbarer und wiedermontierbarer modularer

Parkplatz nach Anspruch 1, wobei ein oder zwei dazwischenliegende Sekundärträger (14) in jeder modularen Struktureinheit (10; 10NL, 10L) vorgesehen sind.

7. Abmontierbarer und wiedermontierbarer modularer Parkplatz nach Anspruch 6, wobei die Anzahl der dazwischenliegenden Sekundärträger (14) zwei beträgt und diese das Deck der modularen Struktureinheit (10; 10NL, 10L) in drei Abteile teilen, wobei die Spannweite (L) des mittleren Abteils (16A) das Doppelte der Spannweite (L/2) der zwei Seitenabteile ist.
8. Abmontierbarer und wiedermontierbarer modularer Parkplatz nach Anspruch 1, wobei das Stahlblech der Bodenplatten (16; 16A, 16B, 16C) gerippt ist.
9. Abmontierbarer und wiedermontierbarer modularer Parkplatz nach Anspruch 1, wobei die Bodenplatten (16; 16A, 16B, 16C) von gemischter Art sind, wobei das Stahlblech mit einer darüberliegenden Schicht aus verstärktem Beton zusammenwirkt.
10. Abmontierbarer und wiedermontierbarer modularer Parkplatz nach Anspruch 1, wobei das Stahlblech der Bodenplatten (16; 16A, 16B, 16C) oben mit mindestens einer Schicht betretbarem/befahrbarem Material bedeckt ist, welches mit dem Stahlblech nicht statisch zusammenwirkt.
11. Abmontierbarer und wiedermontierbarer modularer Parkplatz nach Anspruch 7, wobei alle Struktureinheiten (10NL), welche nicht zwei der parallelen Seiten des Parkplatzes ausbilden, die Bodenplatten (16A, 16B), alle identisch sind und eine Spannweite (L) gleich dem Abstand zwischen den Achsen von zwei dazwischenliegenden Sekundärträgern (14) aufweisen.
12. Abmontierbarer und wiedermontierbarer modularer Parkplatz nach Anspruch 1, wobei ein dritter Sekundärträger (14L) in all denjenigen modularen Struktureinheiten (10L) vorgesehen ist, welche zwei der parallelen Seiten des Parkplatzes ausbilden, wobei die äußerste Bodenplatte (16L) auf diesem letztgenannten Träger (14L) und auf dem benachbarten Sekundärträger (14) liegt.
13. Abmontierbarer und wiedermontierbarer modularer Parkplatz nach Anspruch 1, wobei die Sockel (36) Versteifungsrippen (42) aufweisen, an welche ein ringförmiges Element (46) in einer Ebene parallel zu der Sockelplatte (38) liegend befestigt ist, und gegen welche (46) die Räder von Fahrzeugen stoßen, bevor diese letztgenannten seitlich gegen das vertikale Halteelement (18) stoßen.

14. Abmontierbarer und wiedermontierbarer modularer Parkplatz nach Anspruch 1, wobei ein Element (50) an den Sockeln (36) verwendet werden kann, um einen Schutz gegen Kollisionen mit zumindest einem Teil des Umfangs des unteren Teils des jeweiligen vertikalen Halteelements (18) zu ergeben. 5
15. Abmontierbarer und wiedermontierbarer modularer Parkplatz nach Anspruch 2 und 14, wobei das Schutzelement (50) von einem annähernd C-förmigen Querschnitt ist und im Wesentlichen eine Hälfte des Umfangs des unteren Teils eines vertikalen Halteelements (18) umgibt. 10
16. Abmontierbarer und wiedermontierbarer modularer Parkplatz nach Anspruch 1, wobei die letzte Etage des Parkplatzes mit einer herkömmlichen Abdeckung bedeckt ist. 15
17. Abmontierbarer und wiedermontierbarer modularer Parkplatz nach Anspruch 1, wobei, wenn keine Abdeckung für die letzte Etage des Parkplatzes bereitgestellt wird, dieser letztgenannte Regenwasserabflusskanäle aufweist, welche zwischen den einzelnen Bodenplatten (16; 16A, 16B, 16L) angeordnet sind und welche in entsprechende Fallrohre (34) ableiten. 20 25
18. Abmontierbarer und wiedermontierbarer modularer Parkplatz nach Anspruch 2, 3, 5 und 15, wobei die Fallrohre (34) innerhalb der röhrenförmigen vertikalen Halteelemente (18) angeordnet sind, wobei die erste Platte (28) und die zweite Platte (20) des Verbindungselements (30) ein mittleres Loch (37, 35) zum Durchführen des Fallrohrs (34) aufweisen. 30 35

Revendications

1. Parc de stationnement modulaire démontable et remontable pour des véhicules à moteur, constitué d'au moins un étage supérieur en plus du rez-de-chaussée, et comprenant, en plus d'une ou de plusieurs rampes d'accès vers les étages supérieurs, un nombre déterminé d'unités structurelles modulaires (10 ; 10NL, 10L) et d'éléments de contreventement adéquats (43, 44), chaque unité structurelle modulaire (10 ; 10NL, 10L) comprenant : un plancher carré ou rectangulaire comprenant des poutres en acier (12, 14, 14L) qui supportent une dalle de plancher unique (16) ou plusieurs dalles de plancher côte à côte (16A, 16B, 16L), la dalle de plancher (16) ou les dalles de plancher (16A, 16B, 16L) étant formées en utilisant de la tôle d'acier, quatre éléments de jonction (30), également en acier, sur lesquels le plancher est en appui au niveau de ses quatre coins, quatre éléments de support verticaux en acier (18) au niveau de la partie supérieure desquels un élément de jonction (30) est agencé, et quatre bases en acier (36), chaque base (36) comprenant une plaque de base (38) à partir de laquelle un collier tubulaire (40) s'étend coaxialement vers le haut pour recevoir de manière assez lâche l'extrémité inférieure de l'élément de support vertical relatif (18), caractérisé en ce que :
- le plancher comprend au moins deux poutres de bord en acier (12) parallèles les unes aux autres, chaque élément de support vertical (18) est formé en une seule pièce d'une longueur fixe, dont l'extrémité inférieure peut être insérée directement de manière lâche dans le collier tubulaire (40) de la base relative (36).
2. Parc de stationnement modulaire démontable et remontable selon la revendication 1, dans lequel un élément d'espacement peut être inséré dans l'intérieur du collier tubulaire (40) pour modifier la distance entre la base (36) et l'élément de jonction (30).
3. Parc de stationnement modulaire démontable et remontable selon la revendication 1, dans lequel les éléments de support verticaux (18) sont obtenus à partir de barres profilées tubulaires.
4. Parc de stationnement modulaire démontable et remontable selon la revendication 3, dans lequel les barres profilées tubulaires à partir desquelles les éléments de supports verticaux sont obtenus ont une section transversale carrée, rectangulaire, ou en H.
5. Parc de stationnement modulaire démontable et remontable selon la revendication 1, dans lequel chaque élément de jonction (30) comprend une première plaque fixe (28) similaire à un chapiteau au niveau de la partie supérieure de l'élément de support vertical (18), la première plaque (28), supportant, par l'intermédiaire de barres filetées (22) et d'écrous relatifs (24) et d'écrous de verrouillage (26), une seconde plaque superposée (20), parallèle à la première (28), et espacée de celle-ci, une première extrémité de la poutre de bord relative (12) étant en appui sur la seconde plaque, et étant fixée de manière amovible sur celle-ci.
6. Parc de stationnement modulaire démontable et remontable selon la revendication 1, dans lequel une ou deux poutres secondaires intermédiaires (14) sont fournies dans chaque unité structurelle modulaire (10 ; 10NL, 10L).
7. Parc de stationnement modulaire démontable et remontable selon la revendication 6, dans lequel les poutres secondaires intermédiaires (14) sont au nombre de deux, et divisent le plancher d'une unité structurelle modulaire (10 ; 10NL, 10L) en trois

- baies, la portée (L) de la baie centrale (16A) étant le double de la portée (L/2) des deux baies latérales.
- 8.** Parc de stationnement modulaire démontable et remontable selon la revendication 1, dans lequel la tôle d'acier des dalles de plancher (16 ; 16A, 16B, 16C) est nervurée. 5
- 9.** Parc de stationnement modulaire démontable et remontable selon la revendication 1, dans lequel les dalles de plancher (16 ; 16A, 16B, 16C) sont d'un type mixte, la tôle d'acier coopérant avec une couche sus-jacente de béton renforcé. 10
- 10.** Parc de stationnement modulaire démontable et remontable selon la revendication 1, dans lequel la tôle d'acier des dalles de plancher (16 ; 16A, 16B, 16C) est recouverte sur le dessus d'au moins une couche de matériau pouvant être piétinée/de transit qui ne coopère pas de manière statique avec la tôle d'acier. 20
- 11.** Parc de stationnement modulaire démontable et remontable selon la revendication 7, dans lequel pour la totalité de ces unités structurelles (10NL) qui ne forment pas deux des côtés parallèles du parc de stationnement, les dalles de plancher (16A, 16B) sont toutes identiques et ont une portée (L) égale à la distance entre les axes de deux poutres secondaires intermédiaires (14). 25 30
- 12.** Parc de stationnement modulaire démontable et remontable selon la revendication 1, dans lequel une troisième poutre de bord secondaire (14L) est agencée dans la totalité de ces unités structurelles modulaires (10L) qui forment deux des côtés parallèles du parc de stationnement, la dalle de plancher la plus extérieure (16L) étant en appui sur cette dernière poutre (14L) et sur la poutre secondaire adjacente (14). 35 40
- 13.** Parc de stationnement modulaire démontable et remontable selon la revendication 1, dans lequel les bases (36) présentent des nervures de renforcement (42) sur lesquelles un élément annulaire (46) est fixé, s'étendant dans un plan parallèle à la plaque de base (38), et contre lesquelles (46) les roues de véhicules viennent en contact avant que ces dernières ne viennent en contact latéralement contre l'élément de support vertical (18). 45 50
- 14.** Parc de stationnement modulaire démontable et remontable selon la revendication 1, dans lequel un élément (50) peut être appliqué sur les bases (36) pour fournir une protection contre des collisions avec au moins une partie du périmètre de la partie inférieure de l'élément de support vertical relatif (18). 55
- 15.** Parc de stationnement modulaire démontable et remontable selon les revendications 2 et 14, dans lequel l'élément de protection (50) a une coupe transversale grossièrement en forme de C, et entoure sensiblement la moitié du périmètre de la partie inférieure d'un élément de support vertical (18).
- 16.** Parc de stationnement modulaire démontable et remontable selon la revendication 1, dans lequel le dernier étage du parc de stationnement est recouvert d'un recouvrement habituel.
- 17.** Parc de stationnement modulaire démontable et remontable selon la revendication 1, dans lequel si aucun recouvrement n'est fourni pour le dernier étage du parc de stationnement, ce dernier présente les canaux d'enlèvement d'eau de pluie disposés entre les dalles de plancher individuelles (16 ; 16A, 16B, 16L), et se déchargeant dans deux tuyaux descendants relatifs (34).
- 18.** Parc de stationnement modulaire démontable et remontable selon les revendications 2, 3, 5 et 15, dans lequel les tuyaux descendants (34) sont positionnés dans les éléments de support verticaux tubulaires (18), la première plaque (28) et la seconde plaque (20) de l'élément de jonction (30) présentant un trou central (37, 35) pour le passage du tuyau descendant (34).

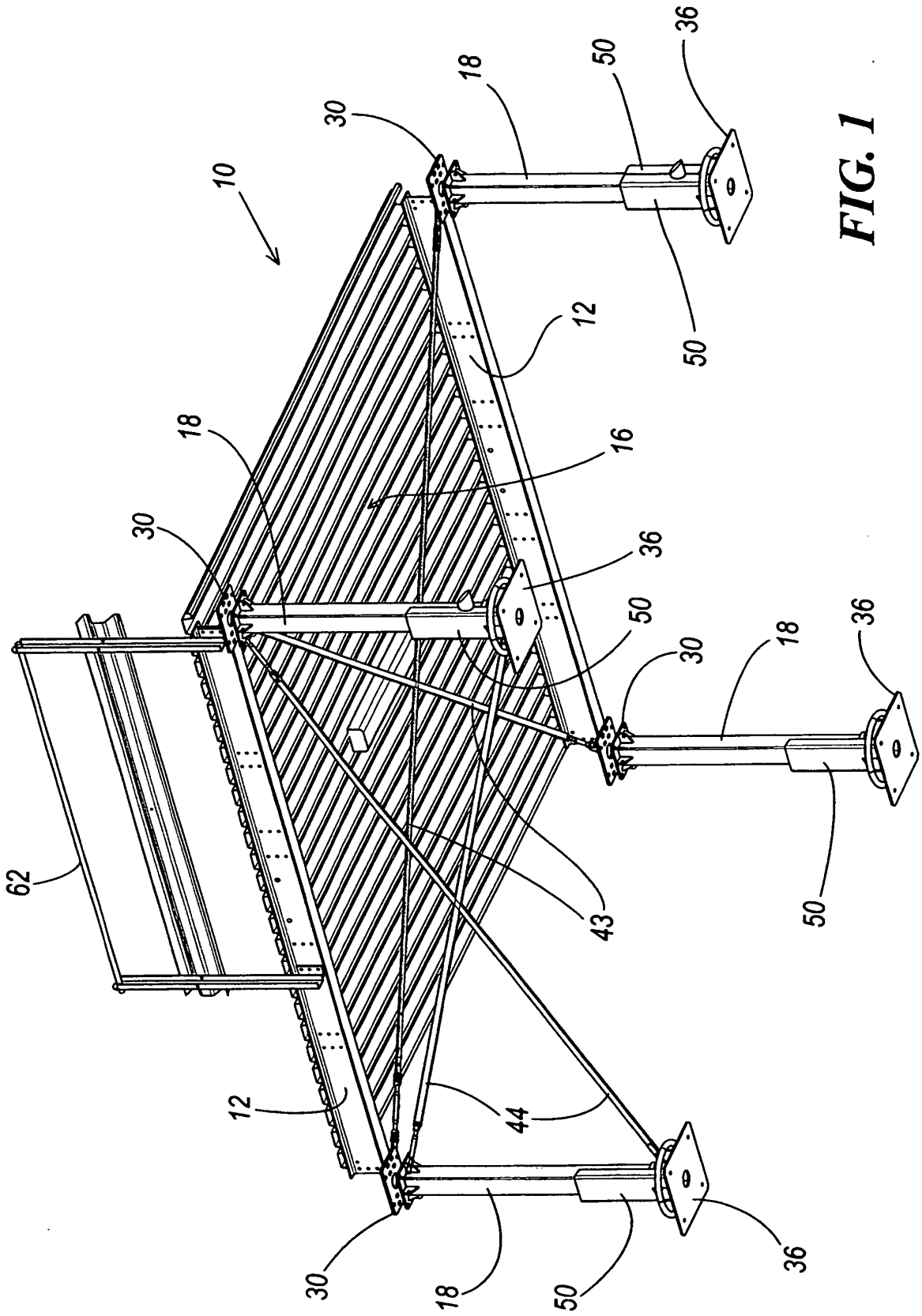

FIG. 1

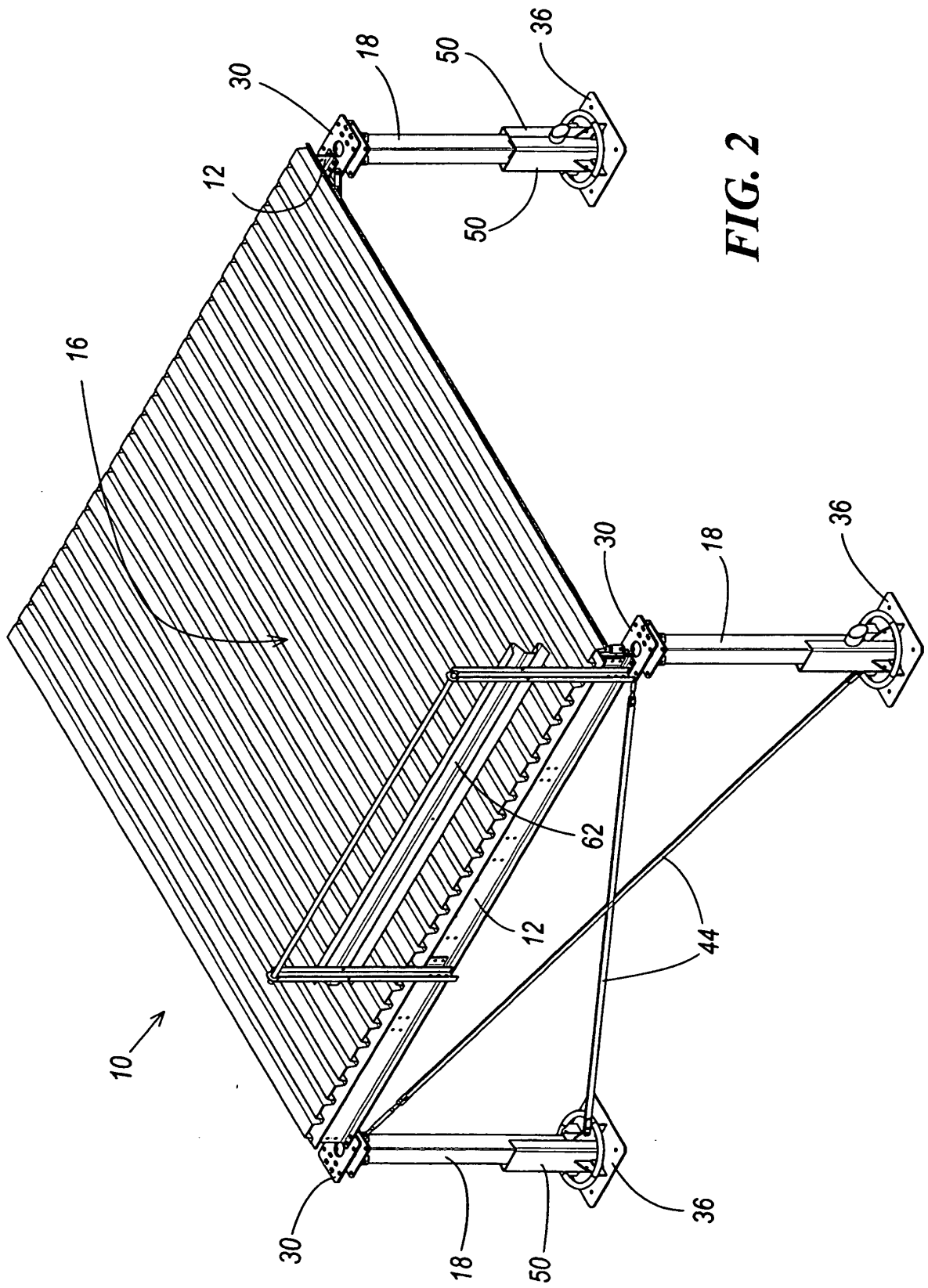

FIG. 2

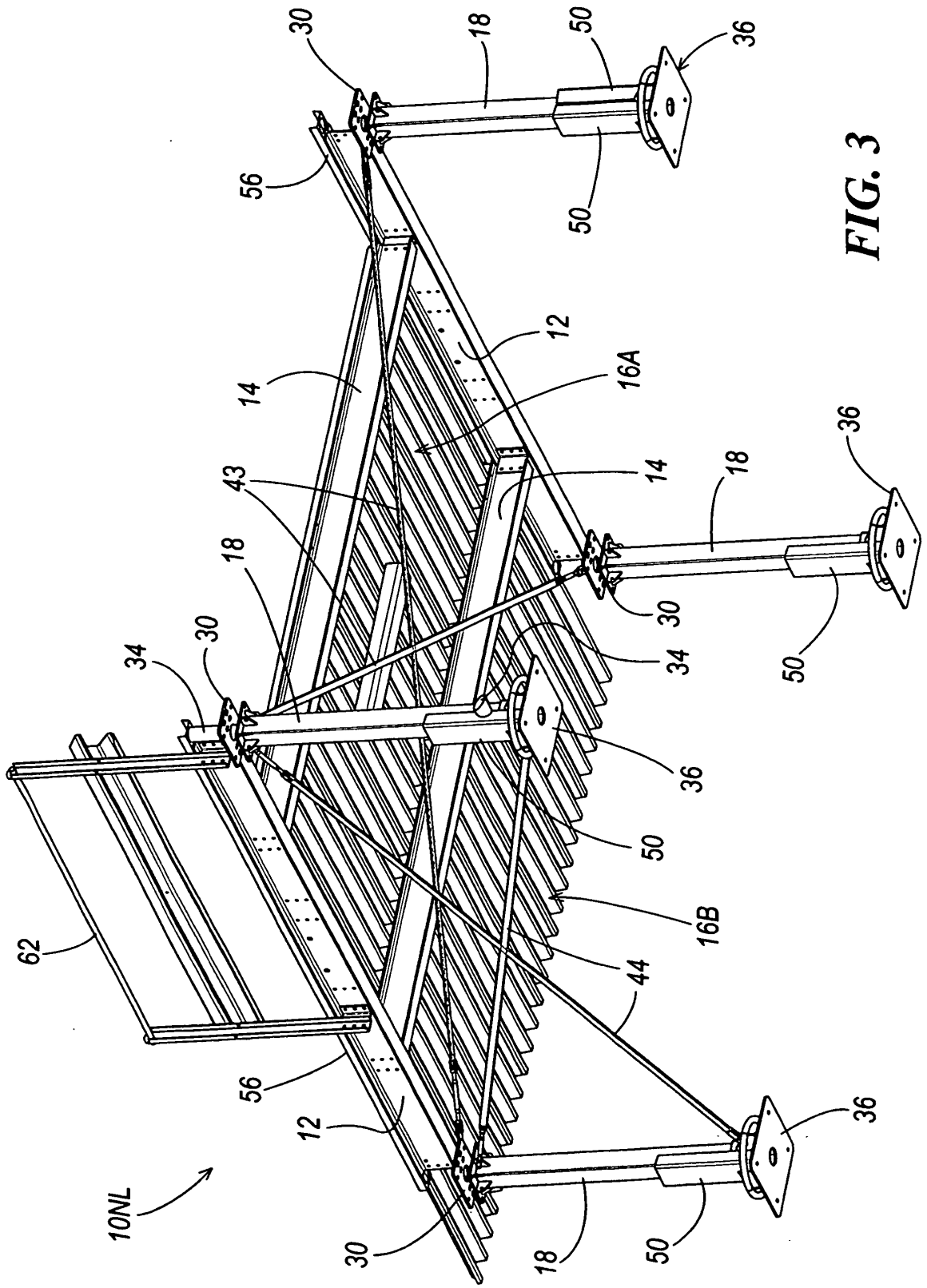

FIG. 3

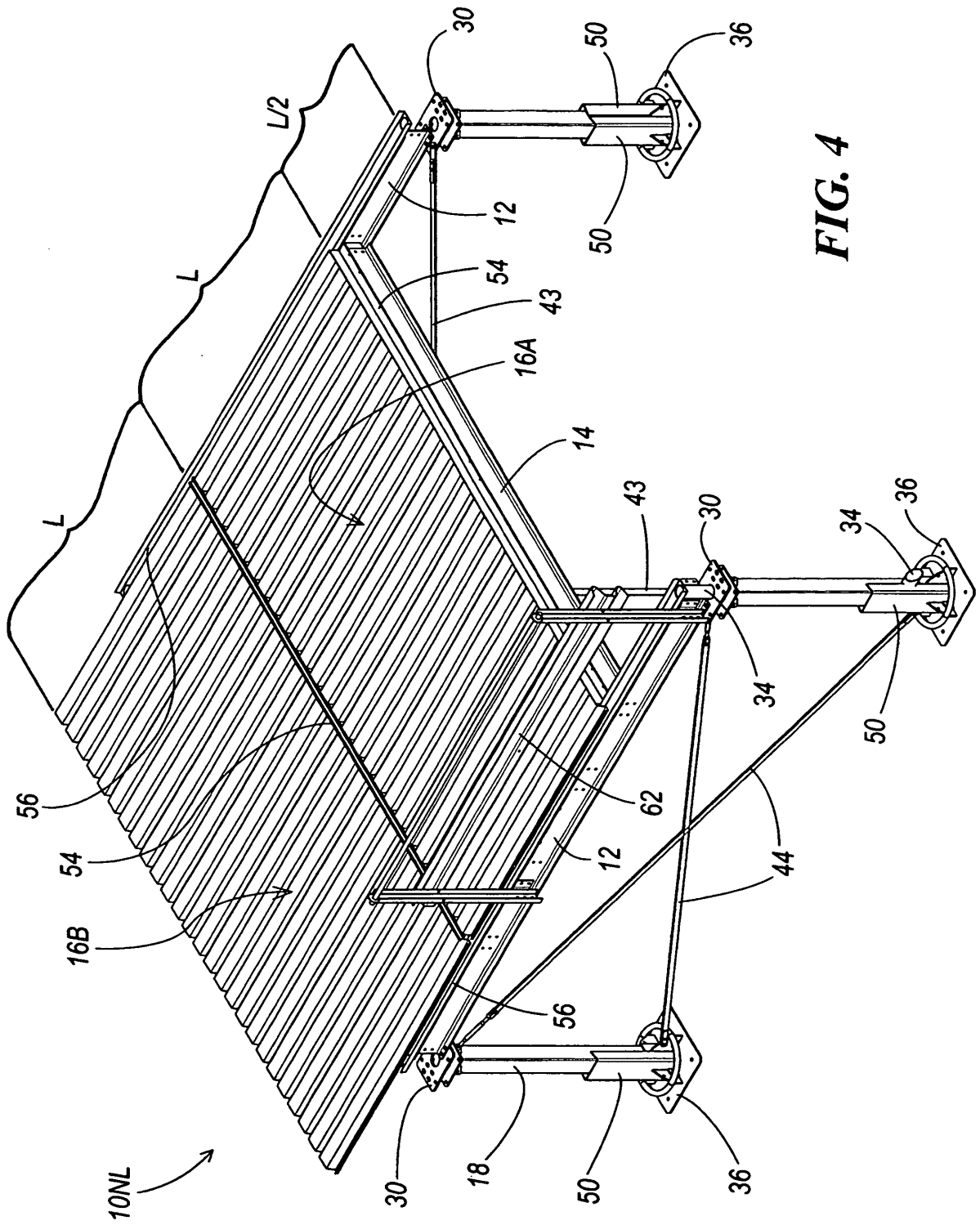
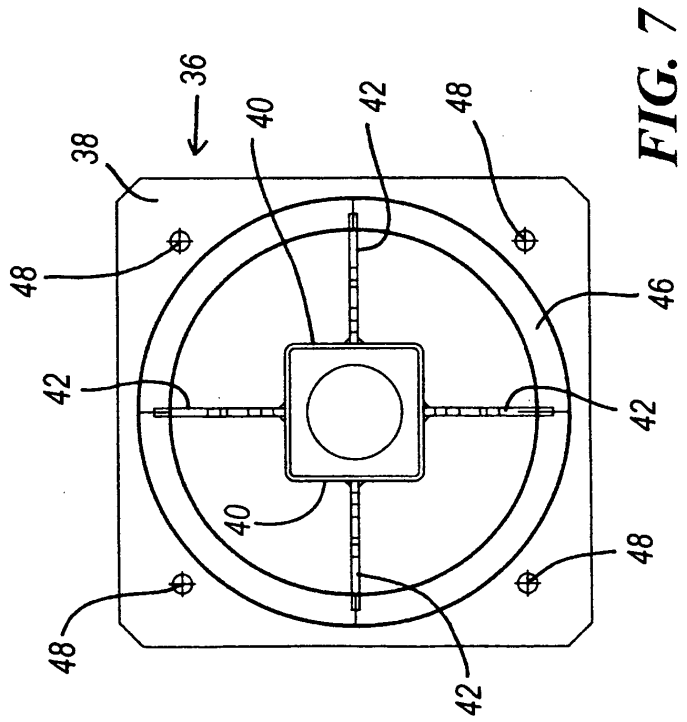
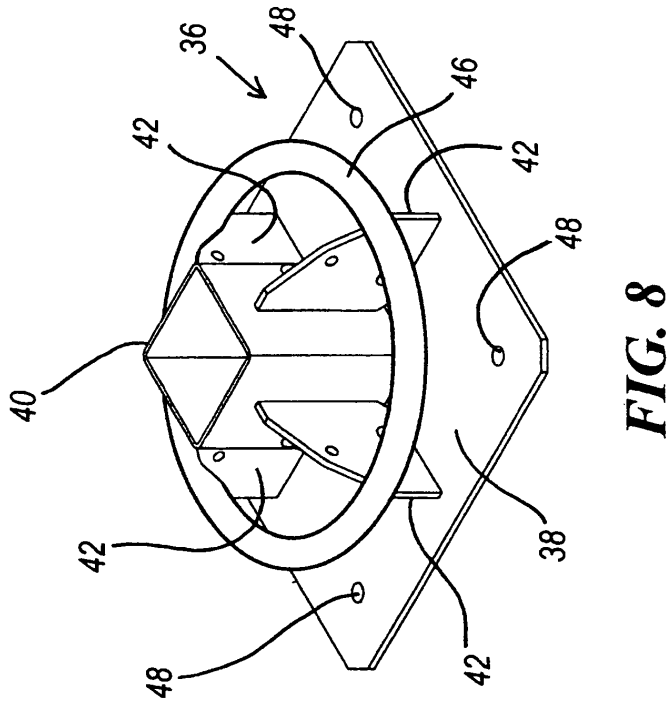
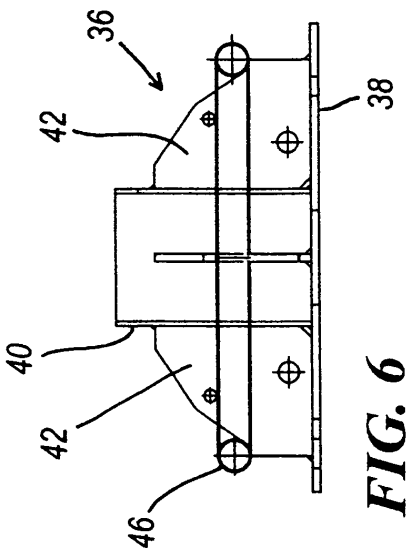

FIG. 4



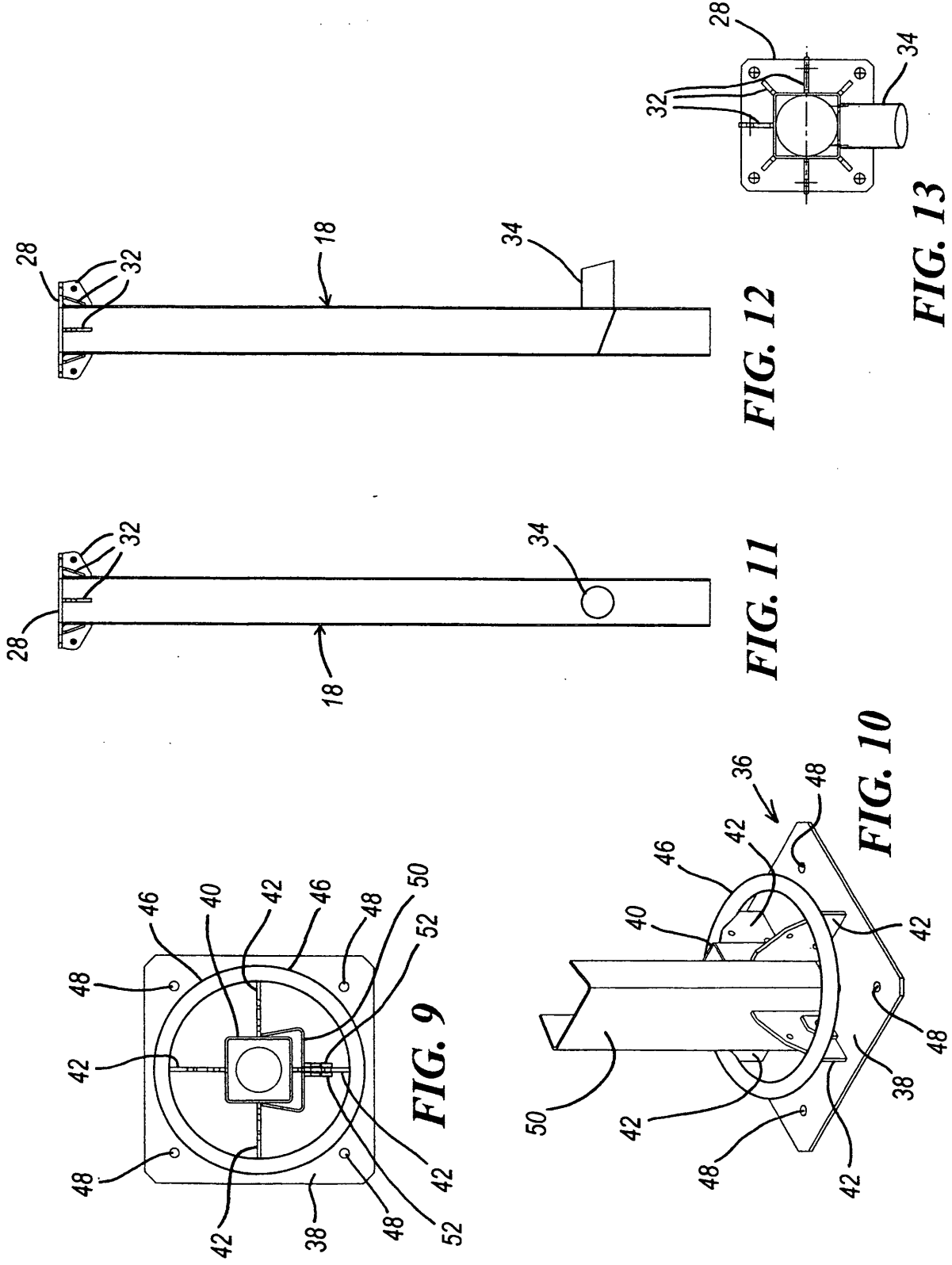

FIG. 9

FIG. 10

FIG. 11

FIG. 12

FIG. 13

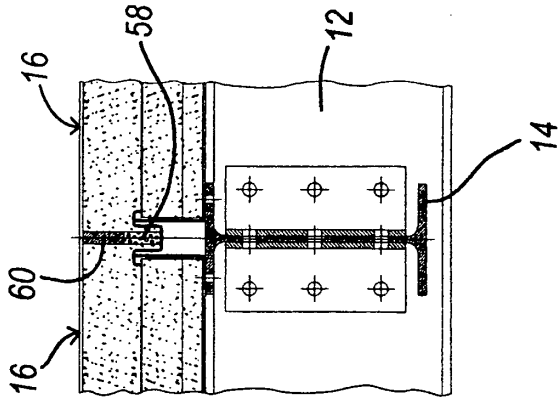

FIG. 15

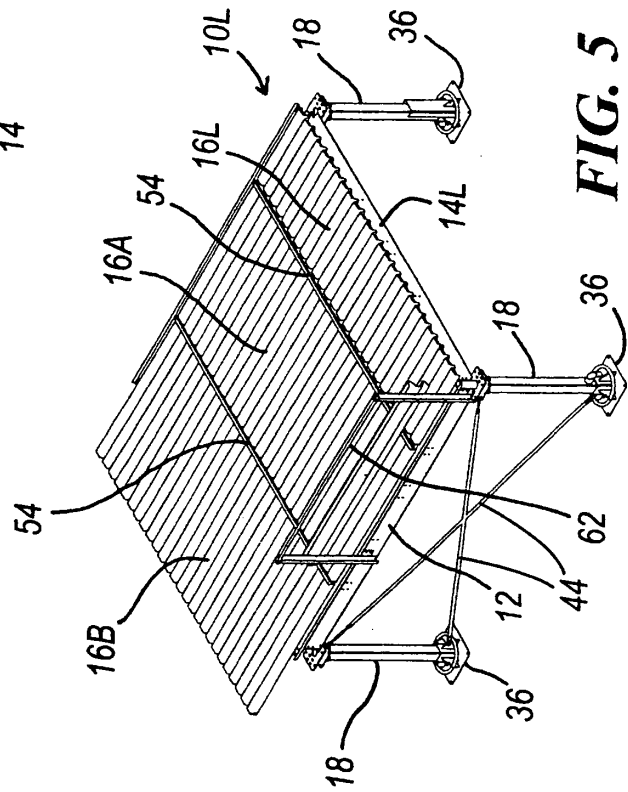

FIG. 5

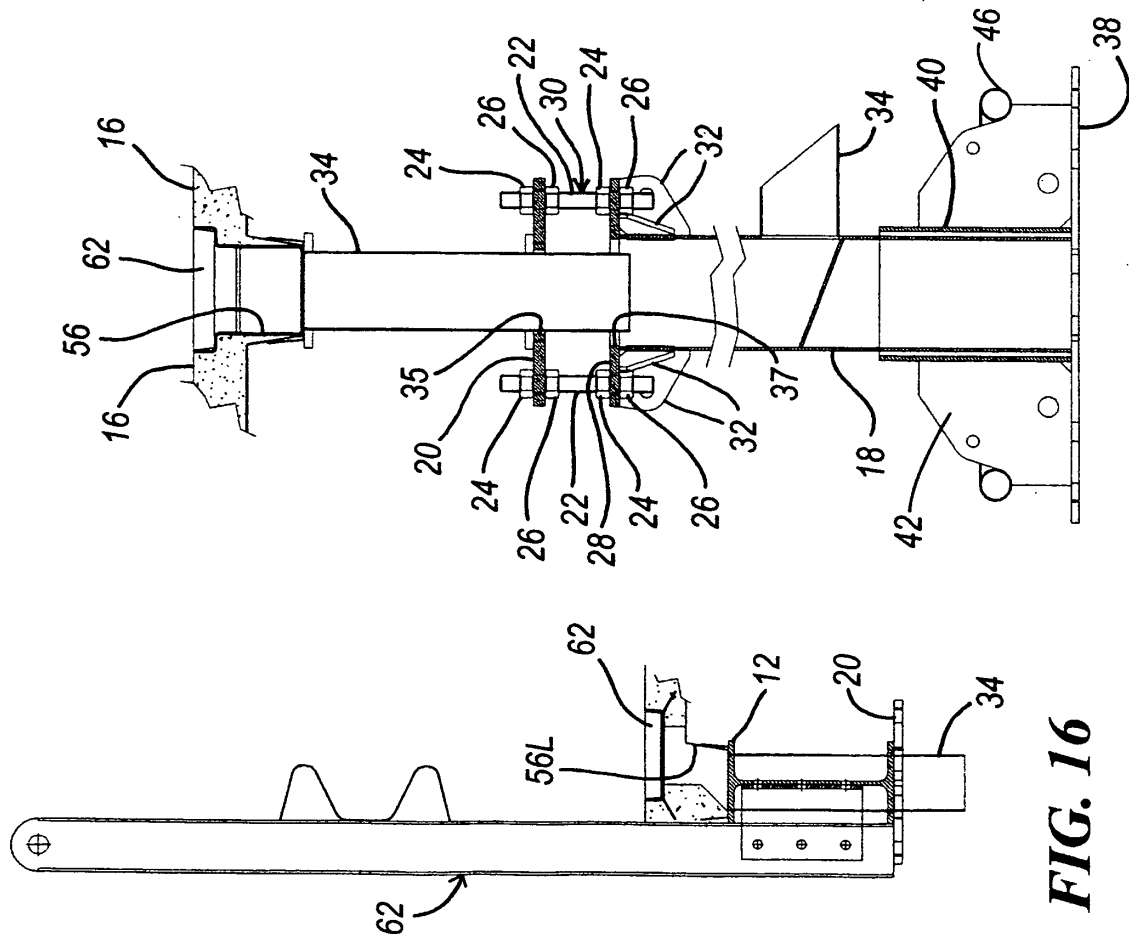

FIG. 14

FIG. 16

REFERENCES CITED IN THE DESCRIPTION

This list of references cited by the applicant is for the reader's convenience only. It does not form part of the European patent document. Even though great care has been taken in compiling the references, errors or omissions cannot be excluded and the EPO disclaims all liability in this regard.

Patent documents cited in the description

- EP 0364414 B1 [0003] [0007] [0008] [0009] [0009] [0011] [0017]
- EP 1165909 B1 [0008] [0009]