



(11) **EP 1 741 814 A3**

(12) **EUROPEAN PATENT APPLICATION**

(88) Date of publication A3: **21.01.2009 Bulletin 2009/04** (51) Int Cl.: **D02H 3/00 (2006.01)**

(43) Date of publication A2: **10.01.2007 Bulletin 2007/02**

(21) Application number: **06009269.9**

(22) Date of filing: **04.05.2006**

(84) Designated Contracting States:  
**AT BE BG CH CY CZ DE DK EE ES FI FR GB GR HU IE IS IT LI LT LU LV MC NL PL PT RO SE SI SK TR**  
Designated Extension States:  
**AL BA HR MK YU**

• **Katayama Co., Ltd.**  
**Nishiwaki-shi, Hyogo (JP)**

(72) Inventors:  
• **Mima, Hiroshi**  
**Kyoto (JP)**  
• **Katayama, Shozo**  
**Hyogo (JP)**

(30) Priority: **05.07.2005 JP 2005195719**  
**07.09.2005 JP 2005258680**

(74) Representative: **Vogeser, Werner et al**  
**Patent- und Rechtsanwälte,**  
**Hansmann & Vogeser,**  
**Albert-Rosshaupter-Strasse 65**  
**81369 München (DE)**

(71) Applicants:  
• **MURATA KIKAI KABUSHIKI KAISHA**  
**Minami-ku**  
**Kyoto-shi**  
**Kyoto 601 (JP)**

(54) **Warping system and warping method**

(57) The present invention provides an arrangement that enables diverse patterns to be inexpensively made in a warping system 1 that winds a predetermined length of warps Y supplied from warping creels 10a, 10b to form a warping beam 11. A plurality of yarn switching mechanisms 3 are arranged in a yarn path formed between the warping creel 10a and the warping beam 11; each of the yarn switching mechanisms 3 includes a yarn selecting device 7 and a splicing device 8 that splices a selected warp. Package groups 4 each including a plurality of sup-

plying packages 5 of different yarn colors or the like are set on the warping creel 10a in association with the respective yarn switching mechanisms 3. A warp group Y, Y, ... unwound from the package group 4 are supplied to the yarn selecting device 7 in the yarn switching mechanism 3. The yarn selecting device 7 selects and supplies at least one warp Y of the supplied warp group Y, Y, ... to the warping beam 11 side. All or selected ones of the yarn switching mechanisms 3, 3, ... are actuated to switch the warps Y within the winding length of the warping beam 11.

FIG. 1

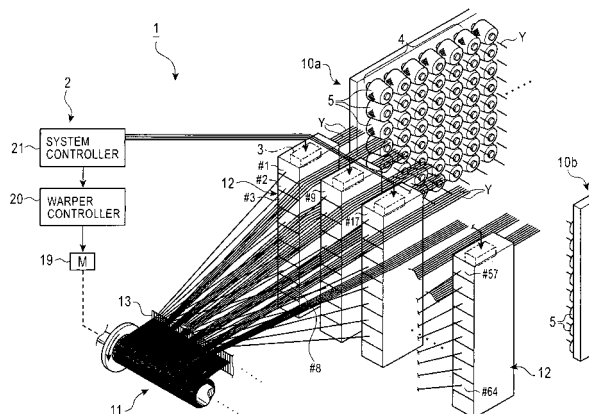

**EP 1 741 814 A3**



EUROPEAN SEARCH REPORT

Application Number  
EP 06 00 9269

DOCUMENTS CONSIDERED TO BE RELEVANT			
Category	Citation of document with indication, where appropriate, of relevant passages	Relevant to claim	CLASSIFICATION OF THE APPLICATION (IPC)
X	EP 1 209 264 A (MAYER TEXTILMASCHF [DE]) 29 May 2002 (2002-05-29)	1,4,7,9, 10,12, 14,16	INV. D02H3/00
D,X	* paragraph [0013]; claims 1-16 * & JP 2002 030537 A (MAYER TEXTILMASCHF) 31 January 2002 (2002-01-31)	1,4,7,9, 10,12, 14,16	
X	* abstract * -----		
X	EP 1 524 341 A (BENNINGER AG MASCHF [CH]) 20 April 2005 (2005-04-20)	1,7	TECHNICAL FIELDS SEARCHED (IPC)  D02H B65H
	* paragraphs [0023], [0024]; figures 1,2 *		
X	----- KR 2005 0065252 A (SUZUKI WAPER LTD [JP]) 29 June 2005 (2005-06-29)	1,7,10, 14	
	* abstract * & DE 10 2004 061550 A1 (SUZUKI WAPER LTD [JP]) 28 July 2005 (2005-07-28)		
	* paragraphs [0009] - [0011]; figures 1-4 * -----		
The present search report has been drawn up for all claims			
Place of search The Hague		Date of completion of the search 15 December 2008	Examiner Pussemier, Bart
CATEGORY OF CITED DOCUMENTS X : particularly relevant if taken alone Y : particularly relevant if combined with another document of the same category A : technological background O : non-written disclosure P : intermediate document		T : theory or principle underlying the invention E : earlier patent document, but published on, or after the filing date D : document cited in the application L : document cited for other reasons ..... & : member of the same patent family, corresponding document	

2  
EPO FORM 1503 03.82 (F04C01)

ANNEX TO THE EUROPEAN SEARCH REPORT  
ON EUROPEAN PATENT APPLICATION NO.

EP 06 00 9269

This annex lists the patent family members relating to the patent documents cited in the above-mentioned European search report. The members are as contained in the European Patent Office EDP file on  
The European Patent Office is in no way liable for these particulars which are merely given for the purpose of information.

15-12-2008

Patent document cited in search report	Publication date	Patent family member(s)	Publication date
EP 1209264 A	29-05-2002	DE 10029492 A1	03-01-2002
		ES 2282173 T3	16-10-2007
		JP 3492335 B2	03-02-2004
		JP 2002030537 A	31-01-2002
-----			
JP 2002030537 A	31-01-2002	DE 10029492 A1	03-01-2002
		EP 1209264 A2	29-05-2002
		ES 2282173 T3	16-10-2007
		JP 3492335 B2	03-02-2004
-----			
EP 1524341 A	20-04-2005	NONE	
-----			
KR 20050065252 A	29-06-2005	CN 1637183 A	13-07-2005
		DE 102004061550 A1	28-07-2005
		JP 4086775 B2	14-05-2008
		JP 2005187972 A	14-07-2005
-----			
DE 102004061550 A1	28-07-2005	CN 1637183 A	13-07-2005
		JP 4086775 B2	14-05-2008
		JP 2005187972 A	14-07-2005
		KR 20050065252 A	29-06-2005
-----			