



(12) **EUROPEAN PATENT APPLICATION**

(43) Date of publication:
31.01.2007 Bulletin 2007/05

(51) Int Cl.:
B65D 75/14 (2006.01)

(21) Application number: **06015651.0**

(22) Date of filing: **27.07.2006**

(84) Designated Contracting States:
AT BE BG CH CY CZ DE DK EE ES FI FR GB GR HU IE IS IT LI LT LU LV MC NL PL PT RO SE SI SK TR
 Designated Extension States:
AL BA HR MK YU

(71) Applicant: **Maniglio, Paolo**
40024 Castel San Pietro Terme (BO) (IT)

(72) Inventor: **Maniglio, Paolo**
40024 Castel San Pietro Terme (BO) (IT)

(74) Representative: **Crugnola, Pietro**
Luppi & Associati S.r.l.
Via Arienti, 15/2A
40124 Bologna (IT)

(30) Priority: **27.07.2005 IT MO20050194**

(54) **Container with magnetic closure**

(57) A container for collectable objects (2) comprises a casing (4) angularly foldable so as to form at least first flap means (6) and second flap means (7), which are adjacent to one another and arranged so that to contain a lamina support (3) for said objects (2) which is inter-

posed between said first flap means (6) and said second flap means (7), magnetic fastening means (15, 16, 25, 26) being provided so that to maintain said first flap means (6) tightly associated to said second flap means (7) when said first flap means (6) and said second flap means (7) are mutually positioned one against the other.

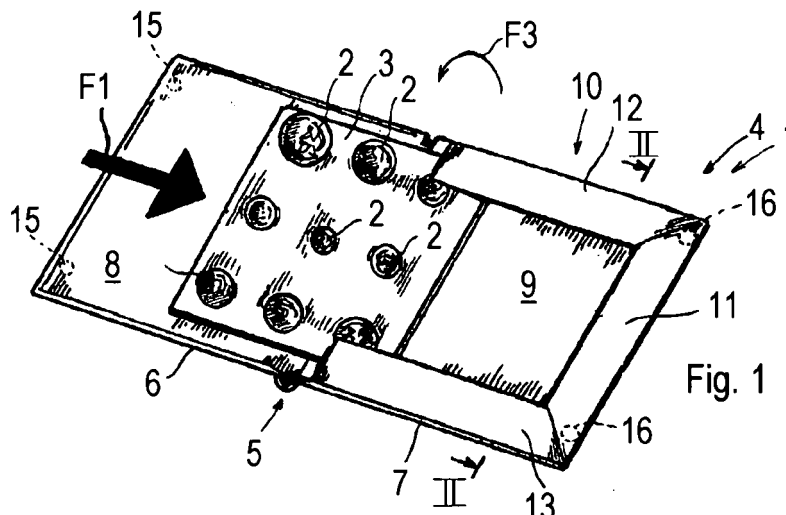

Fig. 1

Description

[0001] The invention relates to a container that can be used for containing collectable objects that are substantially laminar and/or are quite small, such as metal medals and/or coins, or banknotes and/or postage stamps.

[0002] Ring binders are known and used as containers for metal coins and/or medals, which ring binders contain transparent plastic envelopes or pockets. Each pocket is provided with a plurality of pouches, in each of which a single coin or medal can be inserted. At an edge portion of each pocket holes are made, which are aligned and suitably distanced from one another in order to enable a user to insert the pocket between the opened rings of the binder, thereafter to click the rings shut. Thus each pocket is associated to the binder and a user can leaf through the various pockets present therein in the same way as the pages of a book.

[0003] The coins or medals can be inserted in laminar or laminar cardboard supports, quadrilaterally shaped, so-called coin holding cards with "porthole", which are provided with circular windows and which can be inserted in the pockets of the plastic pockets.

[0004] Each binder can be provided with a case, made of leather or synthetic material, having the same shape and size as the binder itself, and into which the binder can be slidably inserted.

[0005] A drawback of the above-described containers is that they are complex to be manufactured. To make a ring binder of known type, the ring-blocking device has to be manufactured, fixed internally of a "book-type" element, and plastic pockets have to be made with holes in positions corresponding to the positions of the rings of the ring-blocking device. This increases the production time and, consequently, the costs for producing the binder.

[0006] A further drawback is that the plastic pockets are subject to wear at the perforated zones due to the repeated movements of the user in inserting, removing and leafing through the pockets. This process of wear can cause a breakage of the pockets or in any case a substantial deterioration in the appearance thereof, and by extension a deterioration in the appearance of the whole binder containing the coins. This is significantly undesirable in a container the function of which is to conserve and especially to present the collection adequately.

[0007] Cardboard or plasticized paper blanks are known too, which are folded into pack-forms or book-forms and can house a laminar support or coin holding card. This coin support can be directly glued by adhesive to a wall of the blank or can be associated thereto by suitable foldable tabs and/or slots realised in the blank. In both cases, the insertion of the coin support into the blank is laborious and complicated.

[0008] Furthermore, the above-described fixing systems are not suitable in cases where the coin support must be repeatedly extracted and inserted into the container, as the tabs and/or the slots are subject to easy

breakage and the adhesive is unsuitable for multiple detachment and reattachment purposes.

[0009] To the above drawback can be added another, namely the closure systems of the above containers, which consist of tabs or strips to be inserted in special slits to achieve a fixed joint, or ribbons or strings to be wound about the container. These closure systems are also laborious and complex to use, and require a certain amount of time for the closure operation to be performed, not to mention a certain degree of expertise in order to avoid destroying the container itself and achieving a complete and reliable closure.

[0010] For these reasons, the above-described known containers are not particularly suited to high-number production, the times necessary for the insertion of the coin supports and for the closure of the containers themselves being very long and therefore the costs being high.

[0011] An object of the invention is to improve the known containers for coins, medals and other similar collectable objects.

[0012] Another object is to provide a container for coins and/or medals that is simple and not expensive to manufacture.

[0013] A further object is to provide a container that is easy and quick to open and close in order to gain access to the coins and/or the medals.

[0014] Still another object is to provide a container that enables easy and fast insertion of the coin and/or medal support internally thereof.

[0015] A further object is to provide a container having an aesthetic appearance that is substantially preservable over a period of time.

[0016] According to the invention, a container is provided for collectable objects comprising a casing angularly foldable so as to form at least first flap means and second flap means, which are adjacent to one another and arranged so that to contain a laminar support for said objects which is interposed between said first flap means and said second flap means, magnetic fastening means being provided so that to maintain said first flap means tightly associated to said second flap means when said first flap means and said second flap means are mutually positioned one against the other.

[0017] Owing to the invention collectable objects, especially but not exclusively coins and/or medals, can be conserved without damaging the laminar support. Furthermore, the container can be very simply and easily opened and closed to insert or extract the laminar support, or to view the objects contained therein. The magnetic fastening means guarantees a reliable and secure closure, even where there is a frequent use of the container.

[0018] Tabs can also be provided at the edges of the first flap means and/or the second flap means, which tabs function as guides for the laminar support. Thus the laminar support is protected from wear when it is inserted into the container and/or removed therefrom, as well as when the collector opens the container to examine the

objects therein contained.

[0019] It is also possible to insert or extract the laminar support easily and rapidly without damaging or breaking the support itself or the container.

[0020] The invention can be better understood and implemented with reference to the enclosed drawings, that show some exemplifying and non limitative embodiments thereof, in which:

Figure 1 is a perspective view of a container for coins and/or medals, shown in an open configuration and during an operation phase;

Figure 2 is a cross section made taken along the plane II-II of Figure 1;

Figure 3 is a perspective view showing the container of Figure 1 during another operation phase;

Figure 4 is a cross section made along the plane IV-IV of Figure 3;

Figure 5 is a perspective view showing the container of Figure 1 during a further operation phase;

Figure 6 is an enlarged partial lateral view, showing the container of Figure 1 in a closed configuration;

Figure 7 is a perspective view of a version of the container of Figure 1, in an open configuration;

Figure 8 is a partial cross section taken along the plane VIII-VIII of Figure 7;

Figure 9 is a front view showing the container of Figure 7 in a closed configuration.

[0021] With reference to figures 1 and 6, a container 1 is provided for containing one or more coins 2 housed in niches or seats realized in a laminar support or coin holding card 3 made for example of plasticized cardboard and quadrilaterally shaped. The container 1 comprises a rectangular casing 4 which can be angularly folded upon itself along a longitudinal groove or creasing 5. The creasing 5 divides the casing 4 into first flap means 6 and second flap means 7, quadrilaterally-shaped, associated one to another and provided respectively with a first surface 8 and a second surface 9. The first surface 8 and the second surface 9 are arranged to face one another during use when first flap means 6 is rotated by 180° with respect to second flap means 7.

[0022] The casing 4 can be made of cardboard, plastic material, leather or another synthetic material.

[0023] The container 1 comprises magnetic fastening means for keeping first flap means 6 tightly associated to second flap means 7 when first flap means 6 and second flap means 7 are put one against the other into a closed configuration.

[0024] The magnetic fastening means comprise one or more first magnets 15 which are incorporated in first flap means 6, i.e. inserted within the thickness thereof, for example in opposite end portions of first flap means 6. The magnets 15, preferably two in number, can be disc-shaped, for example, and can be slim, having a thickness that is variable between 1 mm and 3 mm.

[0025] In a version not illustrated, the first magnets 15

can be applied directly on the first surface 8 of first flap means 6, for example by gluing.

[0026] In a further version not illustrated, the first magnets 15 are inserted in thicknesses or shims fixed to the first surface 8.

[0027] A tab 11 is fixed on an end portion of the second surface 9, which tab 11 is arranged parallel to the creasing 5 and has a cross section which is substantially C-shaped, the concavity of the cross section facing towards the creasing 5. A couple of further tabs 12, 13, each of which has a substantially C-shaped cross section, are fixed to opposite end portions of the second surface 9. The further tabs 12, 13, which are parallel to one another, are arranged in such a way as to have respective concavities thereof opposite to one another, and also to be perpendicular to the tab 11. Taken together, the tab 11 and the further tabs 12 and 13 constitute guiding means 10, being substantially U-shaped and having the concavity facing the creasing 5. In use, the laminar support 3 can be slidably inserted inside the guiding means 10.

[0028] As shown in figure 8, the end tab 11 and the further tabs 12, 13 can have a substantially L-shaped cross section in order to form, together with the second surface 9, the C-shaped concavity suitable for housing the laminar support 3.

[0029] Opposite end portions of the tab 11 can be fixed to corresponding end portions of the further tabs 12, 13.

[0030] In a version not illustrated, the opposite end portions of the end tab 11 can be side-by-side, but not fixed to the corresponding end portions of the further tabs 12, 13.

[0031] In another version not illustrated, the tabs 11, 12 and 13 are made in a single body.

[0032] In a further version not illustrated, the end tab 11 and the further ends tabs 12, 13 are associated both on first flap means 6 and on second flap means 7.

[0033] The magnetic fastening means can further comprise one or more second magnets 16 applied on an internal surface of the tab 11, in proximity of the opposite end portions thereof.

[0034] The second magnets 16 can also be disc-shaped and are preferably two in number.

[0035] In a version not illustrated, second magnets 16 are applied on an external surface of the tab 11.

[0036] In a further version not illustrated, second magnets 16 are inserted in thicknesses or shims fixed to the second surface 9.

[0037] Second magnets 16 of second flap means 7 are provided to interact with the first magnets 15 of first flap means 6, as explained in greater detail herein below.

[0038] The first magnets 15, or alternatively the second magnets 16, can be replaced by ferrous elements able to interact with the magnets.

[0039] During use, a user (not shown) can open the casing 4 by moving first flap means 6 in the direction indicated by the arrow F3, so that to rotate first flap means 6 by an angle of about 180° with respect to second flap means 7.

[0040] Once first flap means 6 and second flap means 7 are aligned, the user grips the laminar support 3 and progressively inserts it into the guiding means 10, sliding the laminar support 3 in a direction indicated by the arrow F1 which is parallel to the first surface 8 and the second surface 9.

[0041] With reference to Figures 2 and 3, the laminar support 3, being slightly smaller than first flap means 6 and/or second flap means 7, can slide into the guiding means 10 along direction F1 up to reach the end tab 11 (Figure 3). In this way, the support 3 stays inserted in the guiding means 10 until the user extracts it again.

[0042] It is thus possible to insert and extract the laminar support 3 easily and rapidly from the container 1, even many times over, without risking to damage or to break the container 1 and/or the support 3.

[0043] Furthermore, it is not necessary to provide perforated plastic pockets for the coins 2, nor ring binders that can ruin the plastic pockets. This permits a container to be obtained which is substantially simple to construct and the aesthetic aspect thereof remains substantially unaffected over time.

[0044] With reference to Figures 5 and 6, after having inserted the support 3 in the guiding means 10, the user can close the casing 4 by moving first flap means 6 in a direction indicated by arrow F2, opposite to the previous direction F3, so as to rotate again first flap means 6 by a 180° angle with respect to second flap means 7. Thus, first flap means 6 is arranged substantially parallel to second flap means 7, and is in contact with second flap means 7 so that the first surface 8 and the second surface 9 face one another.

[0045] With particular reference to Figure 6, when the container 1 is in the closed configuration as described above, the first magnets 15 of first flap means 6 and the corresponding second magnets 16 of second flap means 7 are at a distance from one another which enables a reciprocal magnetic attraction to take place, which magnetic attraction keeps first flap means 6 and second flap means 7 associated to one another.

[0046] To open again the casing 4 of the container 1, it is sufficient to grip first flap means 6 and second flap means 7 and to distance them from one another according to two directions F4, F5, which are parallel and opposite to one another. Thus, the attraction between the first magnets 15 and the second magnets 16 is overcome and first flap means 6 can be rotated with respect to second flap means 7 according to the direction F3.

[0047] Thus the container 1 can be opened and closed to insert or extract the laminar support 3 or simply to view the objects 2 contained therein, very simply and easily. The magnetic fastening means 15, 16 further guarantee a reliable and safe closure, even where the container 1 is frequently used.

[0048] Figures 7, 8 and 9 illustrate a version of the container 1 which differs from the main embodiment in that the casing 4 comprises third flap means 17, associated to second flap means 7 by a further longitudinal

groove or creasing 28. Third flap means 17 has the same shape of first and second flap means 6, 7 and has a third surface 18 on which tabs 11, 12 and 13 are fixed, so as to form the respective guiding means 10 for a laminar support 3. The magnetic fastening means comprise one or more third magnets 26, for example two in number, inserted in the thickness of third flap means 17 and arranged to interact, during use, with fourth magnets 25 inserted in or fixed to first flap means 6. In a close configuration, illustrated in figure 9, first flap means 6 is arranged to be substantially parallel to second flap means 7 and in contact therewith, so that the first surface 8 and the second surface 9 are facing one another. First flap means 6 comprises an external surface 19 opposite the first surface 8. Third flap means 17 is arranged so as to be substantially parallel to first flap means 6 and in contact therewith, so that third surface 9 and the external surface 19 face one another.

[0049] In the illustrated version, guiding means 10 are included on all three surfaces, first 8, second 9 and third, for housing respective laminar supports 3.

Claims

1. Container for collectable objects (2) comprising a casing (4) angularly foldable so as to form at least first flap means (6) and second flap means (7), which are adjacent to one another and arranged so that to contain a laminar support (3) for said objects (2) which is interposed between said first flap means (6) and said second flap means (7), magnetic fastening means (15, 16, 25, 26) being provided so that to maintain said first flap means (6) tightly associated to said second flap means (7) when said first flap means (6) and said second flap means (7) are mutually positioned one against the other.
2. Container according to claim 1, comprising guiding means (10) arranged to slidably receive said laminar support (3).
3. Container according to claim 2, wherein said guiding means (10) are provided at edges of first flap means (6) and/or of second flap means (7).
4. Container according to claim 3, wherein said guiding means (10) comprise an end tab (11) and further tabs (12, 13).
5. Container according to claim 4, wherein said tabs (11, 12, 13) are fixed to a first surface (8) of said first flap means (6) and/or to a second surface (9) of said second flap means (7).
6. Container according to claim 4 or 5, wherein said tabs (11, 12, 13) have a cross section that is substantially C-shaped and/or L-shaped.

7. Container according to claim 6, wherein said tabs (11, 12, 13) have respective concavities arranged for housing corresponding portions of a laminar support (3). 5
8. Container according to any one of claims 4 to 7, wherein said end tab (11) and said further tabs (12, 13) are realised in a single body.
9. Container according to any one of claims 4 to 8, wherein said further tabs (12, 13) are substantially parallel to one another and substantially orthogonal to said end tab (11). 10
10. Container according to claim 1, wherein the magnetic fastening means (15, 16, 25, 26) is incorporated in said flap means (6, 7) and/or in the guiding means (10). 15
11. Container according to claim 1, wherein the magnetic fastening means (15, 16, 25, 26) are applied to external surfaces of flap means (6, 7) and/or of guiding means (10). 20
12. Container according to claim 1, wherein the magnetic fastening means (15, 16, 25, 26) comprises magnets. 25

30

35

40

45

50

55

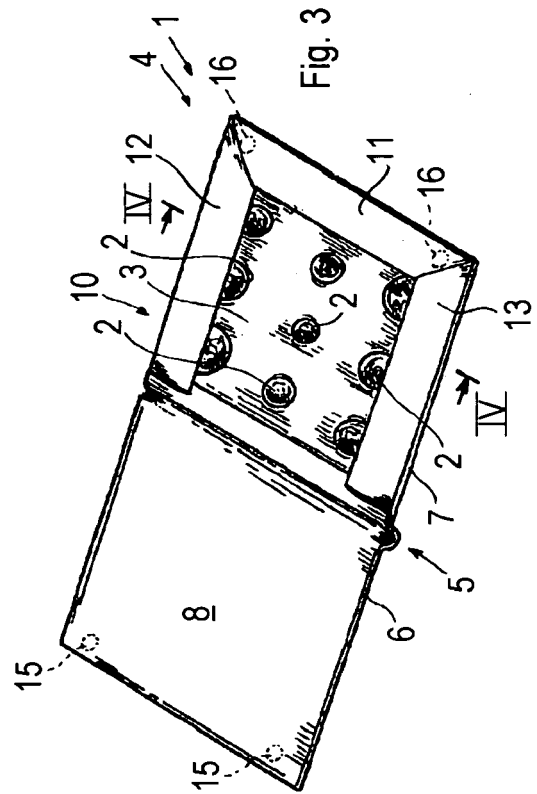
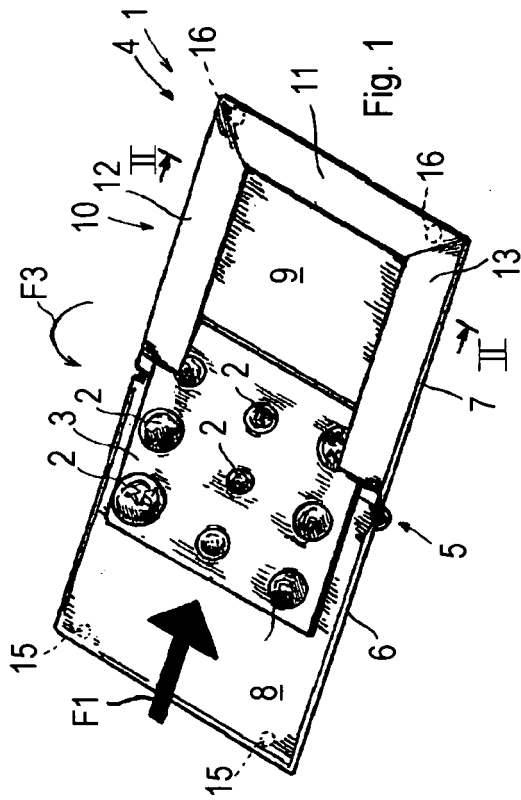

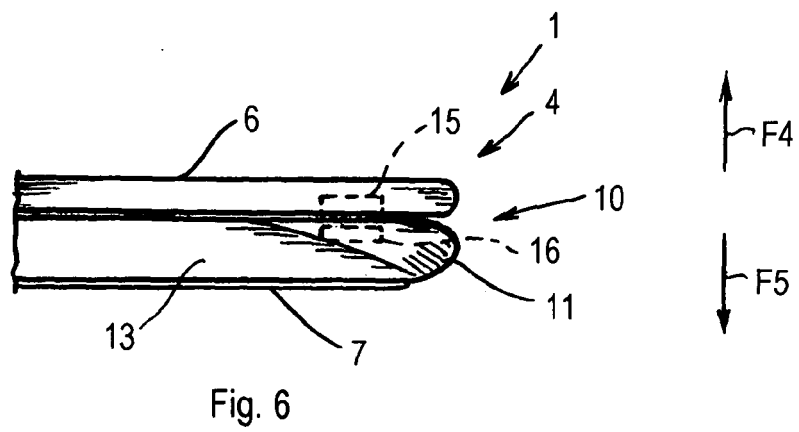
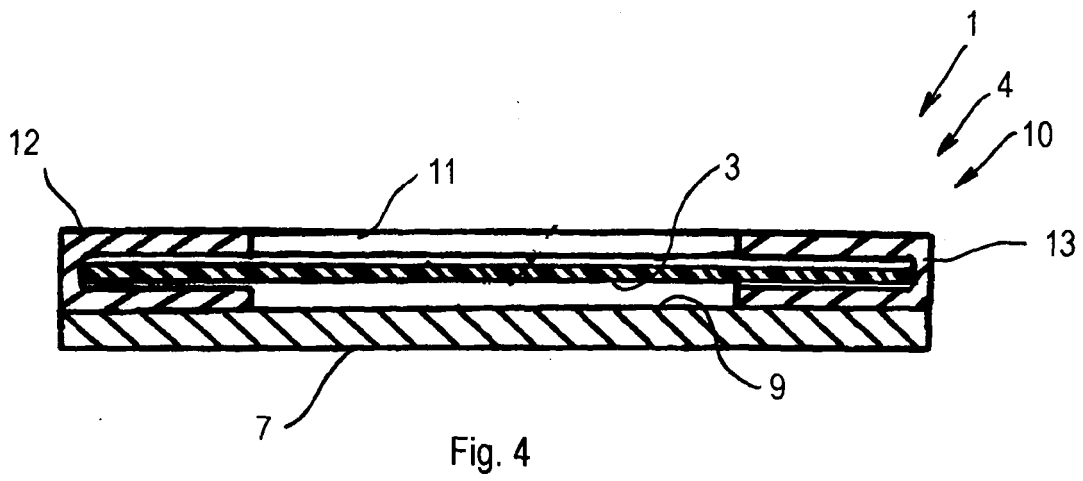
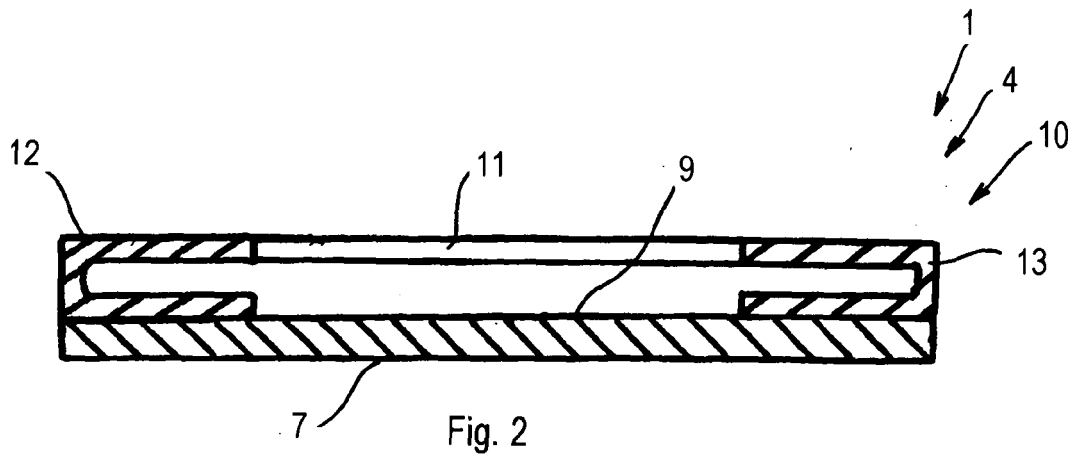

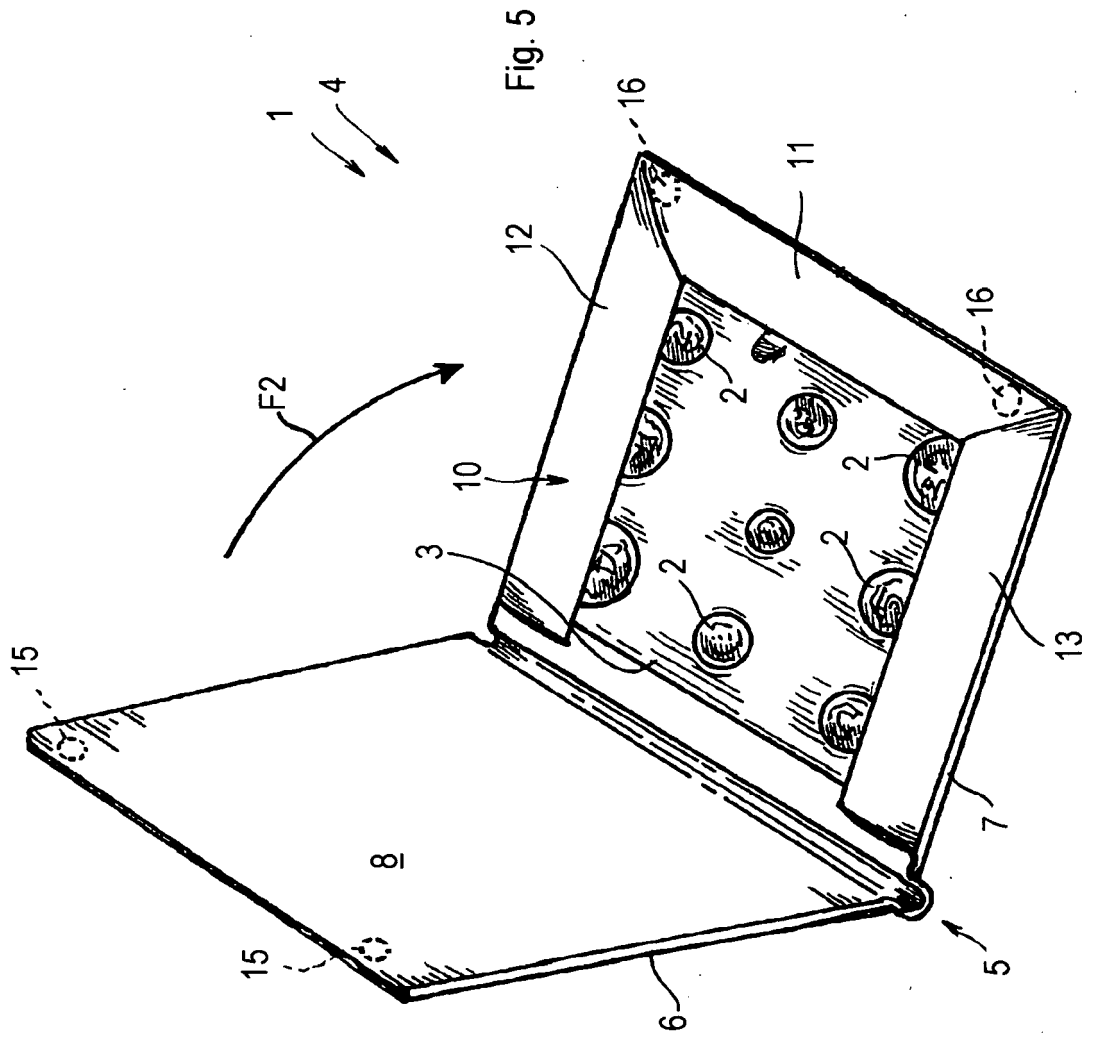

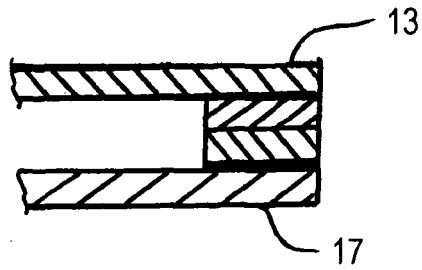

Fig. 8

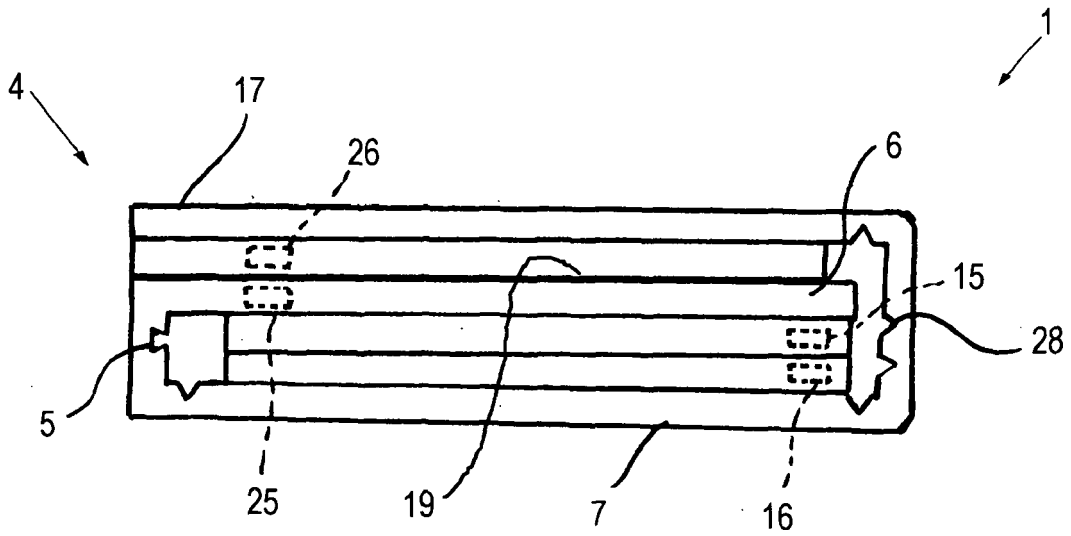

Fig. 9



DOCUMENTS CONSIDERED TO BE RELEVANT			
Category	Citation of document with indication, where appropriate, of relevant passages	Relevant to claim	CLASSIFICATION OF THE APPLICATION (IPC)
X	EP 0 928 748 A (COSMETECH EUROP SA [FR]) 14 July 1999 (1999-07-14)	1,10-12	INV. B65D75/14
Y	* paragraph [0033] - paragraph [0050]; figures 1-4 *	2-9	
Y	----- EP 1 348 637 A (CARTIERE MILIANI FABRIANO S P [IT]) 1 October 2003 (2003-10-01) * paragraph [0001] - paragraph [0021]; figures 1-4 *	2-9	
Y	----- US 6 237 837 B1 (MARTIN JOHN J [US]) 29 May 2001 (2001-05-29) * column 2, line 66 - column 5, paragraph 5; figures 1-11 *	2-9	
A	----- US 1 235 194 A (EDD J. EVANS) 31 July 1917 (1917-07-31) * page 1, line 42 - line 105 *	1	
			TECHNICAL FIELDS SEARCHED (IPC)
			B65D
The present search report has been drawn up for all claims			
Place of search Munich		Date of completion of the search 13 October 2006	Examiner Augustin, Wolfgang
CATEGORY OF CITED DOCUMENTS X : particularly relevant if taken alone Y : particularly relevant if combined with another document of the same category A : technological background O : non-written disclosure P : intermediate document		T : theory or principle underlying the invention E : earlier patent document, but published on, or after the filing date D : document cited in the application L : document cited for other reasons & : member of the same patent family, corresponding document	

1
EPO FORM 1503 03 82 (P04C01)

**ANNEX TO THE EUROPEAN SEARCH REPORT
ON EUROPEAN PATENT APPLICATION NO.**

EP 06 01 5651

This annex lists the patent family members relating to the patent documents cited in the above-mentioned European search report. The members are as contained in the European Patent Office EDP file on
The European Patent Office is in no way liable for these particulars which are merely given for the purpose of information.

13-10-2006

Patent document cited in search report		Publication date	Patent family member(s)	Publication date
EP 0928748	A	14-07-1999	FR 2773540 A1	16-07-1999
EP 1348637	A	01-10-2003	MA 25910 A1	01-10-2003
			OA 12395 A	18-04-2006
			PL 359381 A1	06-10-2003
US 6237837	B1	29-05-2001	NONE	
US 1235194	A		NONE	